

December 1998

RHODOSPIRILLUM RUBRUM POLY- β - HYDROXYALKANOATE SYNTHASE

Thomas E. Clemente

University of Nebraska - Lincoln, tclemente1@unl.edu

Ganish M. Kishore

Creve Coeur, Mo.

Timothy A. Mitsky

Maryland Heights, MO

David M. Stark

Chesterfield, MO

Follow this and additional works at: <http://digitalcommons.unl.edu/plantscifacpub>



Part of the [Plant Sciences Commons](#)

Clemente, Thomas E.; Kishore, Ganish M.; Mitsky, Timothy A.; and Stark, David M., "RHODOSPIRILLUM RUBRUM POLY- β -HYDROXYALKANOATE SYNTHASE" (1998). *Faculty Publications from the Center for Plant Science Innovation*. 12.
<http://digitalcommons.unl.edu/plantscifacpub/12>

This Article is brought to you for free and open access by the Plant Science Innovation, Center for at DigitalCommons@University of Nebraska - Lincoln. It has been accepted for inclusion in Faculty Publications from the Center for Plant Science Innovation by an authorized administrator of DigitalCommons@University of Nebraska - Lincoln.



US005849894A

United States Patent [19]

[11] **Patent Number:** **5,849,894**

Clemente et al.

[45] **Date of Patent:** **Dec. 15, 1998**

[54] **RHODOSPIRILLUM RUBRUM POLY-β-HYDROXYALKANOATE SYNTHASE**

[75] Inventors: **Thomas E. Clemente**, Lincoln, Nebr.; **Ganesh M. Kishore**, Creve Coeur, Mo.; **Timothy A. Mitsky**, Maryland Heights, Mo.; **David M. Stark**, Chesterfield, Mo.

[73] Assignee: **Monsanto Company**, St. Louis, Mo.

[21] Appl. No.: **756,317**

[22] Filed: **Nov. 25, 1996**

Related U.S. Application Data

[60] Provisional application No. 60/007,693, Nov. 29, 1995.

[51] **Int. Cl.**⁶ **C12N 9/00**; C12N 15/00; C12N 1/20; C07H 21/04

[52] **U.S. Cl.** **536/23.2**; 435/183; 435/320.1; 435/252.3; 935/22

[58] **Field of Search** 435/183, 252.3, 435/320.1, 410; 536/23.2; 935/22

[56] References Cited

U.S. PATENT DOCUMENTS

5,480,794	1/1996	Peoples et al.	435/232
5,502,273	3/1996	Bright et al.	800/205
5,610,041	3/1997	Somerville et al.	435/135
5,650,555	7/1997	Somerville et al.	800/205

OTHER PUBLICATIONS

Hustede et al. (1993) Characterization of the polyhydroxyalkanoate synthase gene locus of *Rhodobacter sphaeroides*. *Biotechnology Letters* 15 (7): 709–714, Jul. 1993.

Timm et al. (1992) cloning and molecular analysis of the poly(3-hydroxyalkanoic acid) gene locus of *Pseudomonas aeruginosa* PAo1. *Eur. J. Biochem.* 209: 15–30, Jan. 1992.

Valentin et al. (1993) Cloning and characterization of the *Methylobacterium extorquens* polyhydroxyalkanoic-acid-synthase structural gene. *Appl. Microbiol. Biotechnol.* 39: 309–317, Mar. 1993.

Timm et al. (1994) A general method for identification of polyhydroxyalkanoic acid synthase genes from pseudomonads belonging to the rRNA homology group I. *Appl. Microbiol. Biotechnol.* 40: 669–675, Jun. 1994.

Schembri et al. (1994) Cloning and analysis of the polyhydroxyalkanoic acid synthase gene from an *Acinetobacter* sp.: Evidence that the gene is both plasmid and chromosomally located. *FEMS Microbiology Letters* 118: 145–152, Apr. 1994.

Gerngross et al. (1994) Overexpression and purification of the soluble polyhydroxyalkanoate synthase from *Alcaligenes eutrophus*: Evidence for a required posttranslational modification for catalytic activity. *Biochemistry* 33: 9311–9320, Aug. 1994.

Primary Examiner—Robert A. Wax
Assistant Examiner—Einar Stoce
Attorney, Agent, or Firm—Gary M. Bond; Arnold, White & Durkee

[57] ABSTRACT

Isolated DNA fragments encoding a *Rhodospirillum rubrum* (ATCC 25903) polyhydroxyalkanoate (PHA) synthase, or biologically functional equivalents thereof, are provided. Also provided is the deduced amino acid sequence of the *R. rubrum* PHA synthase. These molecules are useful in the production of PHAs in bacteria and plants.

10 Claims, 2 Drawing Sheets

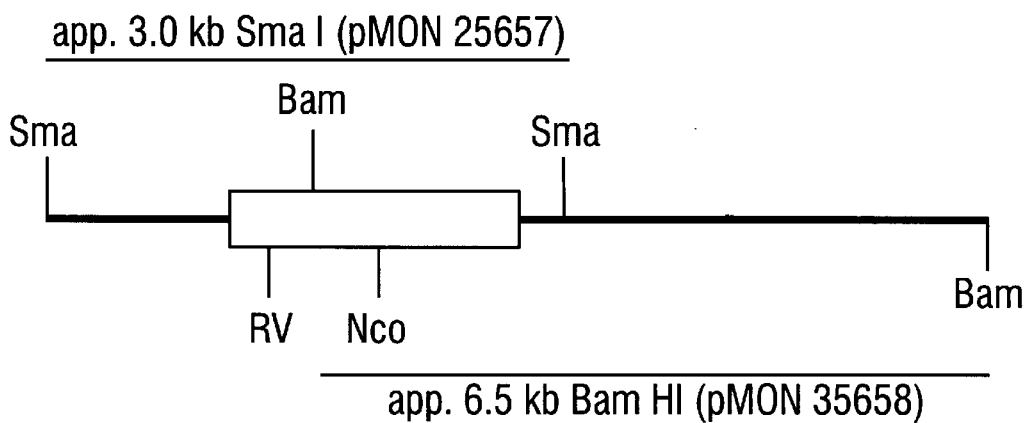

FIG. 1

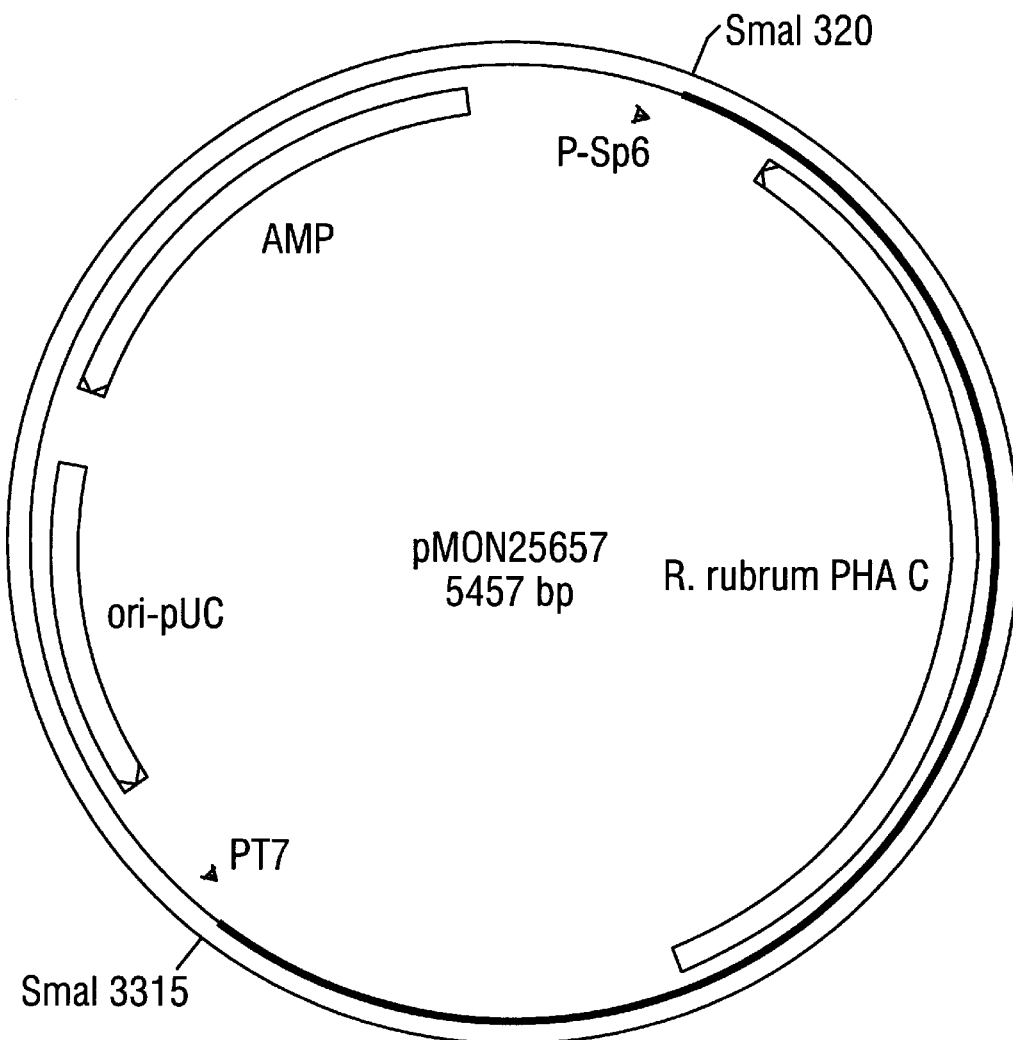

FIG. 2

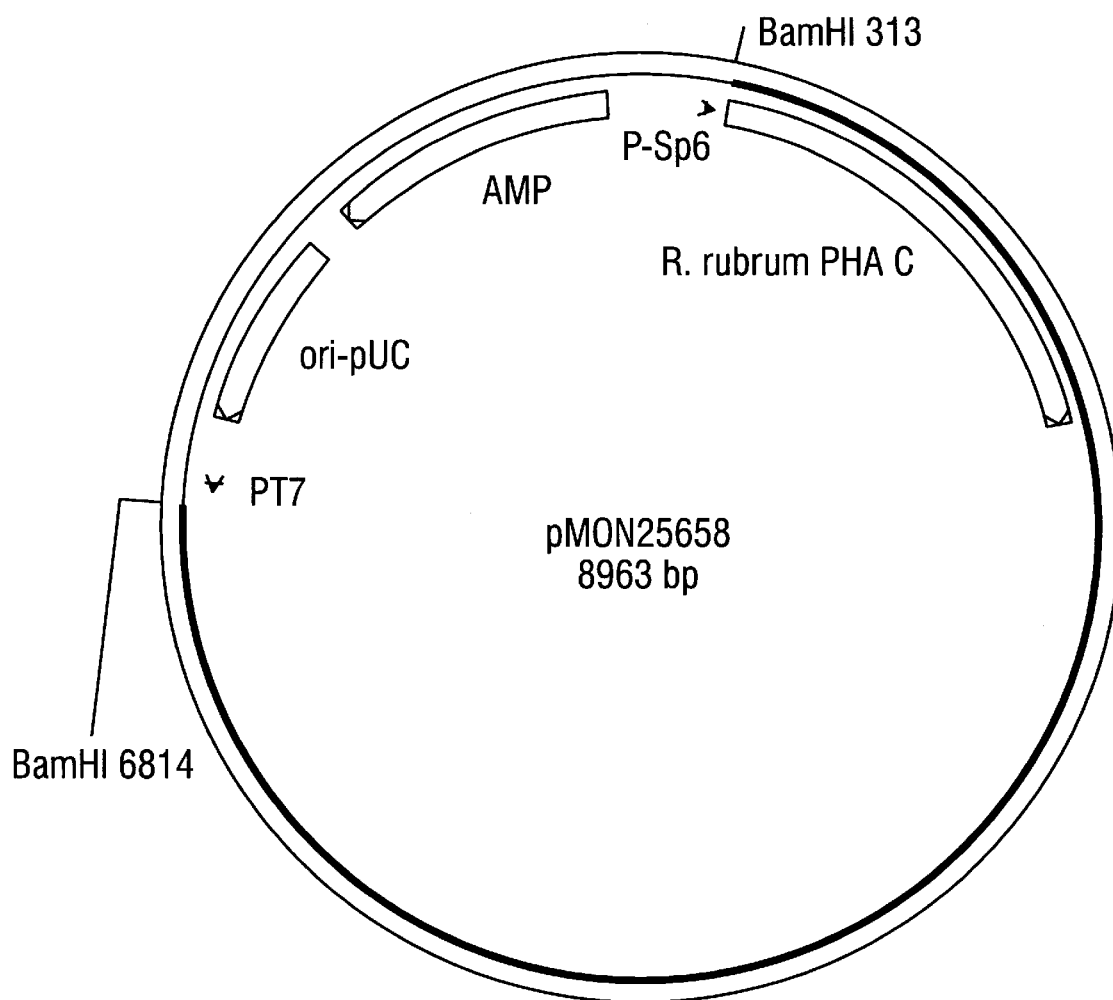

FIG. 3

RHODOSPIRILLUM RUBRUM POLY- β -HYDROXYALKANOATE SYNTHASE

This application claims the benefit of provisional application Ser. No. 60/007,693, filed Nov. 29, 1995.

BACKGROUND OF THE INVENTION

1. Field of the Invention

The present invention relates to poly- β -hydroxyalkanoate (PHA) synthases, such as that from *Rhodospirillum rubrum*, which exhibit flexible substrate specificity. These synthases can be expressed in transformed microorganisms and plants to produce poly- β -hydroxyalkanoates (PHAs) possessing varied physical properties depending upon the monomers incorporated therein.

2. Description of Related Art

The production of intracellular polyesters belonging to the class of polymers known as poly- β -hydroxyalkanoates (PHAs) has been observed in a wide array of prokaryotic organisms (Anderson and Dawes (1990) *Microbiol. Rev.* 54:450). The monomers composing the polyesters range in length from C4 (β -hydroxybutyrate) to C12 (β -hydroxydodecanoate) (Lageveen et al. (1988) *Appl. Env. Microbiol.* 54:2924). This class of polyesters has attracted much attention as a potential alternative to conventional petrochemical-derived plastics.

PHAs are broadly characterized according to the monomers that constitute their backbone. Polymers composed of C4-C5 units are classified as short chain length (scl) PHAs; polymers containing monomers of C6 units and above are classified as medium chain length (mcl) PHAs. The primary structure of the polymer influences the physical properties of the polyester.

The metabolic pathways leading to the formation of PHAs have not been elucidated for all organisms. The most extensively studied PHA biosynthetic pathway is that of *Alcaligenes eutrophus* (Peoples et al. (1989) *J. Biol. Chem.* 264:15298 and Valentin et al. (1995) *Eur. J. Biochem.* 227:43). This organism is capable of forming either a homopolymer of C4 (polyhydroxybutyrate, PHB) or a co-polymer of C4-C5 (PHB-PHV, polyhydroxybutyrate-polyhydroxyvalerate) (Koyama and Doi (1995) *Biotechnol. Lett.* 17:281). Hence, *A. eutrophus* is classified as a scl PHA organism. Similarly, *Pseudomonas* species generate a polymer composed of monomers ranging in length from C6 to C12 (Timm and Steinbüchel (1990) *Appl. Environ. Microbiol.* 56:3360 and Lageveen et al. (1988) *Appl. Environ. Microbiol.* 54:2924), and are classified as mcl PHA organisms.

The polymerization of the D-3-hydroxyacyl-CoA substrates is carried out by PHA synthases. The substrate specificity of this class of enzyme varies across the spectrum of PHA producing organisms. This variation in substrate specificity of PHA synthases is supported by indirect evidence observed in heterologous expression studies (Lee et al. (1995) *Appl. Microbiol. Biotechnol.* 42:901 and Timm et al. (1990) *Appl. Microbiol. Biotech.* 33:296). Hence, the structure of the backbone of the polymer is strongly influenced by the PHA synthase responsible for its formation.

The phototrophic, purple, non-sulphur bacterium *Rhodospirillum rubrum* (ATCC 25903) is capable of accumulating PHA (Anderson and Dawes (1990) *Microbiol. Rev.* 54:450 and Brandl et al. (1989) *Inter. J. Biol. Macromol.* 11:49). The PHA synthase from this strain of *Rhodospirillum* is quite promiscuous, based on the PHA co-polymers it

is capable of generating when fermented with a diverse range of carbon substrates under PHA-accumulating conducive conditions (Brandl et al., supra, and Ulmer et al. (1994) *Macromolecules* 27:1675).

SUMMARY OF THE INVENTION

The present invention provides an isolated DNA fragment comprising a nucleotide sequence encoding an enzyme having *Rhodospirillum rubrum* PHA synthase enzymatic activity. This fragment comprises a PHA synthase gene from *Rhodospirillum rubrum* (ATCC 25903) encoding an enzyme possessing flexible substrate specificity. This gene and the PHA synthase encoded thereby, as well as biologically functional equivalents thereof, respectively, can be used in the production of novel co-polymers of PHA in both prokaryotic and eukaryotic organisms, including plants. Transformed bacteria and transgenic plants comprising and expressing this gene or its equivalents will be able to polymerize both 3-hydroxy-acyl-ACP and/or 3-hydroxyacyl-CoA substrates, and thereby produce novel biodegradative polyesters having physical properties similar to those of petrochemical-derived plastics.

Further scope of the applicability of the present invention will become apparent from the detailed description provided below. However, it should be understood that the following detailed description and specific examples, while indicating preferred embodiments of the present invention, are given by way of illustration only since various changes and modifications within the spirit and scope of the invention will become apparent to those skilled in the art from this detailed description.

BRIEF DESCRIPTION OF THE DRAWINGS

The above and other objects, features, and advantages of the present invention will be better understood from the following detailed description taken in conjunction with the accompanying drawings, all of which are given by way of illustration only and are not limitative of the present invention, in which:

FIG. 1 shows a partial restriction map of the two genomic subclones derived from the 21–23 kb Eco RI genomic fragment harboring the PHA synthase from *R. rubrum*. The open reading frame (ORF) of the PHA synthase from *R. rubrum* is indicated by an open box. The 3.0 kb Sma I subclone resides in pMON 25657 (FIG. 2) and carries the entire ORF. The 6.5 kb Bam HI fragment residing in pMON 25658 (FIG. 3) is missing the 5' region of the PHA synthase ORF, but contains additional sequence beyond the 3' end. RV: EcoRV.

FIG. 2 is a map of pMON 25657. The solid black line represents the 3.0 kb Sma I subclone containing the entire *R. rubrum* PHA synthase ORF within this plasmid. The open box corresponding to *R. rubrum* PHA C shows the coding region for the *R. rubrum* PHA synthase. PT7: promoter element for T7 RNA polymerase; P-Sp6: promoter element for Sp6 RNA polymerase.

FIG. 3 is a map of pMON 25658. The solid black line represents the 6.5 kb Bam HI subclone containing the 5' region of the *R. rubrum* PHA synthase ORF. The open box corresponding to *R. rubrum* PHA C shows the coding region for the *R. rubrum* PHA synthase contained within this plasmid. PT7: promoter element for T7 RNA polymerase; P-Sp6: promoter element for Sp6 RNA polymerase.

SEQ ID NOS:1–15 depict the following

SEQ ID NO:1 shows the nucleotide sequences of the coding and non-coding strands of the PHA synthase-

encoding DNA fragment from *R. rubrum* (ATCC 25903), as well as the deduced amino acid sequence.

SEQ ID NO:2 shows the deduced amino acid sequence of the *R. rubrum* PHA synthase encoded by SEQ ID NO:1 when the ATG at nucleotide positions 8–10 is the translational initiation start site.

SEQ ID NO:3 shows the deduced amino acid sequence of the *R. rubrum* PHA synthase encoded by SEQ ID NO:1 when the ATG at nucleotide positions 122–124 is the translational initiation start site.

SEQ ID NO:4 shows the deduced amino acid sequence of the *R. rubrum* PHA synthase encoded by SEQ ID NO:1 when the ATG at nucleotide positions 200–202 is the translational initiation start site.

SEQ ID NOS:5–15 show the amino acid sequences of the PHA synthases from the following 11 microorganisms:

SEQ ID NO:5: *Alcaligenes eutrophus*

SEQ ID NO:6: *Methylobacterium extorquens*

SEQ ID NO:7: *Pseudomonas aeruginosa* (synthase 1)

SEQ ID NO:8: *Pseudomonas aeruginosa* (synthase 2)

SEQ ID NO:9: *Paracoccus denitrificans*

SEQ ID NO:10: *Pseudomonas oleovorans* (synthase 1)

SEQ ID NO:11: *Pseudomonas oleovorans* (synthase 2)

SEQ ID NO:12: *Acinetobacter* sp. RA3849

SEQ ID NO:13: *Rhizobium meliloti*

SEQ ID NO:14: *Rhodococcus ruber*

SEQ ID NO:15: *Rhodobacter sphaeroides*

Organisms included in the sequence listing include *P. denitrificans* (*Paracoccus denitrificans*, unpublished, accession D43764); *R. sphaeroides* (*Rhodobacter sphaeroides*, Hustede and Steinbüchel (1993) *Biotechnol. Lett.* 15:709, accession L17049); *M. extorquens* (*Methylobacterium extorquens*, Hustede and Steinbüchel (1993), supra, accession L07893); *R. meliloti* (*Rhizobium meliloti*, unpublished, accession U17227); *R. rubrum* (*Rhodospirillum rubrum*, ATCC 25903); *Acinetobacter* (*Acinetobacter* sp. RA3849, Schembri et al. (1994) *FEMS Microbiol. Lett.* 118:145, accession U04848); *A. eutrophus* (*Alcaligenes eutrophus*, Peoples and Sinskey (1989) *J. Biol. Chem.* 264:15298, accession J05003); *P. aeruginosa-1* (*Pseudomonas aeruginosa* (synthase 1), Timm and Steinbüchel (1992) *Eur. J. Biochem.* 209:15, accession S29305); *P. oleovorans-1* (*Pseudomonas oleovorans* (synthase 1), Huisman et al. (1991) *J. Biol. Chem.* 266:2191, accession number M58445); *P. aeruginosa-2* (*P. aeruginosa* (synthase 2), Timm and Steinbüchel 1992, supra, accession S28379); *P. oleovorans-2* (*Pseudomonas oleovorans* (synthase 2), Huisman et al. 1991, supra, accession number M58445); and *R. ruber* (*Rhodococcus ruber*, Pieper and Steinbüchel (1992) *FEMS Microbiol. Lett.* 96:73, accession S25725).

DETAILED DESCRIPTION OF THE INVENTION

The following detailed description is provided to aid those skilled in the art in practicing the present invention. Even so, the following detailed description should not be construed to unduly limit the present invention as modifications and variations in the embodiments herein discussed can be made by those of ordinary skill in the art without departing from the spirit or scope of the present inventive discovery.

The contents of each of the references cited herein, including the contents of each of the references cited within each of these references, are herein incorporated by reference in their entirety.

The polymerization of 3-hydroxyacyl-CoA substrates to produce the class of polyesters known as PHAs within prokaryotic cells is catalyzed by PHA synthases. PHA synthases tend to possess inherent substrate specificities that restrict an organism to producing either scl or mcl PHAs. A subset of prokaryotic organisms has been identified that are capable of generating PHAs from monomers having chain lengths that span the classifications scl/mcl. These include species within the genera *Nocardia*, *Pseudomonas*, *Thiocapsa*, *Chromatium*, *Aeromonas*, *Rhodococcus*, and *Rhodospirillum*. Isolation and characterization of the PHA synthase from a representative of this class of PHA producing organisms provides a means of generating PHAs that possess unique physical properties in heterologous prokaryotic and eukaryotic systems. In the present invention, the PHA synthase from *R. rubrum* (ATCC 25903) was targeted as a representative synthase from this class of PHA producing organisms.

The genes required for the production of PHA within *A. eutrophus* have been cloned and sequenced (Schubert et al. (1988) *J. Bacteriol.* 170:5837). These include *phbA*, *phbB*, and *phbC*, encoding β -ketothiolase, acetoacetyl-CoA reductase, and PHB synthase, respectively. At the protein level, there are known conserved amino acid residues that serve as hallmarks for PHA synthases (Peoples and Sinskey (1989) *J. Biol. Chem.* 264:15298; FIGS. 4A–4E). Under conditions of low stringency, the PHA synthase from *A. eutrophus* can be used as a heterologous probe to screen genomic libraries to identify PHA synthases from other organisms (Timm and Steinbüchel (1992) *Eur. J. Biochem.* 209:15; Valentin and Steinbüchel (1992) *Appl. Microbiol. Biotechnol.* 39:309; Liebergesell et al. (1993) *Appl. Microbiol. Biotechnol.* 40:292).

As described below, an Eco RI partial genomic library of *R. rubrum* (ATCC 25903) was constructed in λ Dash II® (Stratagene, Catalogue No. 247212), and positive plaques were isolated and further characterized. These results are described in Example 2. A hybridizing signal was localized on an approximately 21–23 kb Eco RI fragment. The hybridizing signal was further localized to a 6.5 kb Bam HI fragment and a 3.0 kb Sma I fragment from within the approximately 21–23 kb Eco RI fragment. The 6.5 kb Bam HI and 3.0 kb Sma I fragments were subsequently subcloned into pSP72 (Promega, Catalogue No. P2191). These results are described in Example 3.

The 3.0 kb Sma I fragment subcloned into pSP72 was designated pMON 25657 (FIG. 2). The ORF of the PHA synthase resided within the 3.0 kb Sma I fragment.

Analysis of the activity of this flexible PHA synthase from *R. rubrum* (ATCC 25903) in heterologous systems will facilitate the identification of subdomains within the ORF that are responsible for substrate specificities across this third class of PHA synthases that are capable of incorporating both scl and mcl monomers into polyesters.

EXAMPLE 1

In Vivo Biosynthetic Activity of the PHA Synthase From *R. Rubrum* (ATCC 25903) With Various Substrates

Table 1 shows the composition of PHA polymer accumulated by *R. rubrum* (ATCC 25903) after 5 days of growth followed by 10 days under PHA-synthetic conducive conditions. Fermentation with the various carbon sources and analysis of the methyl esters were conducted as described by Brandl et al. ((1989) *Inter. J. Biol. Macromol.* 11:49). The %

PHA column shows the percentage of the dry weight of the cells attributable to polymer. The % MOL column shows the percent molar ratio of the methyl esters of the C4 3-hydroxybutyrate (3HB), the C5 3-hydroxyvalerate (3HV), and the C6 3-hydroxyhexanoate (3HH), respectively, in the accumulated PHA.

TABLE 1

Evaluated Carbon Source	Dry Wt		% MOL		
	of Cells	% PHA	3HB	3HV	3HH
0.10% Caproic Acid	360 mg	2.6	76	4	20
0.02% 3-octanoic	700 mg	0.3	60	40	trace
0.04% 3-hexanoic	480 mg	5.0	67	9	24

These results show that the PHA synthase from *R. rubrum* (ATCC 25903) is capable of incorporating both scl and mcl monomers into a copolymer. This enzyme was therefore targeted as representative of the synthases from the subset of organisms that have been identified as having such biosynthetically flexible synthases.

EXAMPLE 2

Cloning of a DNA Fragment From *R. rubrum* (ATCC 25903) Encoding PHA Synthase

Molecular biological techniques routinely employed in the art are described, for example, in Sambrook et al., *Molecular Cloning A, Laboratory Manual*, Second Edition, 1989, Cold Spring Harbor Laboratory Press, Cold Spring Harbor, N.Y., and Ausubel et al., *Current Protocols in Molecular Biology*, 1995, John Wiley & Sons, Inc. The PHA synthase-encoding DNA of *R. rubrum* (ATCC 25903) was isolated from a partial Eco RI genomic library using such techniques as described below.

Growth and Harvesting of Bacteria

R. rubrum (ATCC 25903) was grown anaerobically under illumination (60 watt incandescent bulb) at 30° C. in R 8 A H medium (ATCC *Catalogue of Bacteria and Bacteriophages*, 18th edition, 1992, p. 435). Five 25 ml cultures were grown for 5 days. Cultures were subsequently centrifuged at 5,000 rpm for 10 min. to pellet the cells.

Bacterial Lysis and Extraction of DNA

The bacterial pellet obtained from 100 mls of culture was resuspended in 10 mls cell lysis solution composed of 50 mM glucose, 10 mM EDTA (pH 8.0), 25 mM Tris HCl (pH 8.0), 2 mg/ml lysozyme, and 1% SDS. This suspension was frozen on dry ice for 15 min. and placed at 70° C. in a water bath for 10 min. This freeze/heat step was repeated two additional times to lyse the cells.

Lysed cells were extracted four times in phenol/chloroform/ isoamyl alcohol, 25:24:1, v/v/v. Nucleic acids were subsequently precipitated by the addition of 2x volume of cold absolute ethanol. The resulting pellet was resuspended in 5 ml TE (10:1, pH 8.0) buffer. The resultant solution was dialyzed overnight against 2 liters TE (10:1, pH 8.0) buffer at 4° C. The dialyzed solution was treated with 3 µof RNAase (10 mg/ml) for 30 min. at 37° C. The DNA was precipitated with 0.1 vol of 3.0M sodium acetate and 2 volumes absolute ethanol. The resultant pellet was resuspended in 1 ml TE (10:1, pH 8.0) buffer.

Digestion and Cloning of Genomic DNA

Genomic DNA was digested with Eco RI (Boehringer) according to the manufacturer's instructions at 37° C. for 15, 30, and 45 min., and fragments ranging in size from 15–23 kb were purified from 0.8% low melting point agarose gel by a series of phenol/chloroform extractions.

The purified Eco RI fragments of *R. rubrum* genomic DNA were ligated into λ DASH II replacement vector (Stratagene, Catalogue No. 247212) following the manufacturer's protocol. *E. coli* strains XL1-Blue MRA and XL1-blue MRA (P2) were utilized as host to titer the library. The library was subsequently amplified to a titer of 10⁶ plaques (based on XL1-Blue MRA (P2) host) per µl.

Approximately 40,000 plaques from the amplified library were plated out across 20 100 mmx15 mm petri plates. Duplicate plaque lifts were conducted after allowing the plates to chill at 4° C. for 5 hours. Plaque lifts were conducted by placing nylon membrane filters (S+S membrane, Midwest Scientific, Catalogue No. 77550) on the chilled petri plates for 10 min. The membranes were then placed, plaque side up, onto 3MM paper saturated with 0.2M NaOH/0.5M NaCl for 2 min. The filters were subsequently transferred, plaque side up, to 3MM paper saturated with 0.4M Tris-HCl (pH 7.6), 2x SSC for 2 min. The denatured recombinant phages were crosslinked by exposing the filters to 1200x100 µJOULES UV (Stratalinker® 2400). The filters were subsequently washed in 5x SSC prior to hybridization.

The filters were prehybridized in a solution containing 6x SSC, 5x Denhardt's, 100 µg/ml fish sperm DNA, and 0.1% SDS at 55° C. for approximately 2 hours. Filters were hybridized in the same medium as that for prehybridization utilizing the PHA synthase ORF from *A. eutrophus* (a gift from D. Dennis and C. Somerville) as a heterologous probe. The radiolabeled *A. eutrophus* PHA synthase ORF probe was prepared by random priming following the manufacturer's protocol (Prime-it II™ kit, Stratagene, Catalogue No. 300385) incorporating dCT³²P. Filters were hybridized for approximately 14 hours at 55° C. The filters were subsequently washed in 2x SSC and 0.1% SDS 2x, 15 min. each, at room temperature, followed by two additional washes in 1x SSC, 0.1% SDS at 55° C., prior to exposure to X-ray film for approximately 14 hours (Kodak imaging film, X-OMAT-AR, Catalogue No. 165-1512). Based on the duplicate lifts, 20 potential positive regions (each region contained 2–4 plaques) were isolated from the plates. Each of the 20 regions was placed in 1 ml of SM buffer (5.8 g/l NaCl, 2.0 g/l MgSO₄.H₂O, 50 ml of 1M Tris-HCl, pH 7.5, and 5.0 ml of 2% gelatin) with 20 µl chloroform, and placed at 4° C. for 5 hours. One µl of the SM buffer containing phage particles eluted from the isolated regions was used as inoculum for 200 µl of prepared host bacteria (XL1-Blue MRA (P2)). The secondary plaques were re-screened under the identical stringency described above. From the secondary screen, 18 positive plaques were selected for a tertiary screen to assure homogeneity. Following the tertiary screen, six positive plaques were carried on for phage DNA preparations.

Bacteriophage λ preparations were prepared following standard procedures (Sambrook et al., *Molecular Cloning A, Laboratory Manual*, Second Edition, 1989, Cold Spring Harbor Laboratory Press, Cold Spring Harbor, N.Y.). Aliquots of the DNA (approximately 1 µg) recovered from the six bacteriophage λ preparations were digested with the restriction enzymes Eco RI, Hind III, Not I, and Bgl II. All six preparations displayed the identical banding pattern following electrophoresis on a 0.8% agarose gel. Southern blot analysis of this gel, using as probe the radiolabeled PHA

synthase ORF from *A. eutrophus* under the identical stringency used in the screening of the genomic library, was conducted. The purified PHA synthase ORF from *A. eutrophus* (approximately 10 ng) was included as a positive control. A single hybridizing band (Eco RI lane, approximate size of 21–23 kb) within each of the digested lanes was clearly visible following 1.5 hour exposure, although the intensity of the hybridizing fragment within the positive control lane was significantly greater than that observed within the digested bacteriophage preparations.

A single bacteriophage λ DNA preparation was subsequently digested with 15 single restriction enzymes and 12 double combinations of enzymes in order to localize the hybridizing fragment. The digests were electrophoresed on a 0.8% agarose gel along with the PHA synthase ORF of *A. eutrophus* as a positive control for the subsequent Southern blot analysis. The hybridizing fragment was localized to an approximately 6.5 kb Bam HI fragment, a 3.0 kb Sma I fragment, and a 10.0 kb Xho I fragment.

EXAMPLE 3

Sequencing of the *R. rubrum* PHA Synthase-Encoding Fragment

The 3.0 kb Sma I and 6.5 kb Bam HI fragments were subcloned into the vector pSP72 (Promega, Catalogue No. P2191). The resultant plasmids are referred to as pMON 25657 and pMON 25658, respectively, and are schematically shown in FIGS. 2 and 3, respectively.

The DNA sequence of the 3.0 kb Sma I fragment within pMON 25657 was determined by double stranded sequence reactions utilizing a Prism™ DyeDeoxy Terminator Cycle Sequence Kit (Applied Biosystems, Catalogue No. 401434) or a Sequence™ Version 2.0 DNA Sequence Kit (USB, Catalogue No. 70770). Double stranded reactions utilizing the former kit were analyzed on an Applied Biosystems 37 DNA sequencer, while the double stranded DNA sequence reactions performed with the latter kit were resolved by running the reaction products on an 8% acrylamide gel and subsequently visualizing the sequence ladder by autoradiography. All reactions were conducted following manufacturers' protocols.

The entire PHA synthase ORF from *R. rubrum* (ATCC 25903) resided within the 3.0 kb Sma I fragment harbored in pMON 25657. The 3' end of the PHA synthase ORF was proximal to the sp6 primer. region within pSP72. A series of primers was designed to sequence both strands of the DNA that encode the PHA synthase from *R. rubrum*. The sequences of the coding and non-coding strands derived using these primers is shown in SEQ ID NO:1.

There are three putative translational initiation start sites in SEQ ID NO:1, i.e., at positions 8–10, 122–124, and 200–202, respectively. The corresponding amino acid sequences encoded thereby are shown in SEQ ID NOS:2–4, respectively. Most PHA synthases have a molecular weight in the range from 62–64 kD. Based on the predicted size (64 kD) of the deduced amino acid sequence shown in SEQ ID NO:3, and the location of a putative ribosomal binding site (GGGAGG) nine bases upstream of the ATG start codon at nucleotide positions 122–124 within SEQ ID NO:1, it is possible that the ATG at nucleotide positions 122–124 is the actual start site. There is also a purine-rich consensus-like sequence (GAGAAAAG) eight bases upstream of the ATG codon at nucleotide positions 200–202 as well.

EXAMPLE 4

Peptides, Polypeptides, and Proteins Biologically Functionally Equivalent To *R. rubrum* PHA Synthase

The present invention includes not only the *R. rubrum* PHA synthase encoded by the nucleotide sequence shown in

SEQ ID NO:1, but also biologically functional equivalent peptides, polypeptides, and proteins. The phrase “biologically functional equivalent peptides, polypeptides, and proteins” denotes peptides, polypeptides, and proteins that exhibit the same or similar PHA synthase enzymatic activity as the PHA synthase of *R. rubrum* when assayed biologically by complementation utilizing the PHA-minus mutants of *Pseudomonas putida* (GpP104) (Huisman et al. (1991) *J. Biol. Chem.* 266:2191) or *Alcaligenes eutrophus* (DSM 541) Schlegel et al. (1970) *Arch. Microbiol.* 71:283), or enzymatically in vitro by monitoring the release of coenzyme A with DTNB (Valentin et al. (1994) *Appl. Microbiol. Biotechnol.* 40:699) or radiometrically (Gerngross et al. (1994) *Biochemistry* 33:9311). By “the same or similar PHA synthase enzymatic activity” is meant PHA synthase enzymatic activity differing from that of *R. rubrum* PHA synthase by about $\pm 30\%$ or less, preferably by about $\pm 20\%$ or less, more preferably by about $\pm 10\%$ or less, in such assays. These peptides, polypeptides, and proteins can contain a region or moiety exhibiting sequence similarity to a corresponding region or moiety of the *R. rubrum* PHA synthase disclosed herein, but this is not required as long as they exhibit the same or similar PHA synthase activity as that of the *R. rubrum* PHA synthase.

The *R. rubrum* PHA synthase is useful not only in the enzymatic synthesis of PHAs, but also as an antigen for the preparation of antibodies that can be used to purify or detect this PHA synthase.

Peptides, polypeptides, and proteins biologically functionally equivalent to *R. rubrum* PHA synthase can occur in a variety of forms as described below.

Conservative Amino Acid Changes in the *R. rubrum* PHA Synthase Amino Acid Sequence

Peptides, polypeptides, and proteins biologically functionally equivalent to *R. rubrum* PHA synthase include amino acid sequences containing conservative amino acid changes in the fundamental *R. rubrum* PHA sequence. In such amino acid sequences, one or more amino acids in the sequence is (are) substituted with another amino acid(s), the charge and polarity of which is (are) similar to that of the native amino acid, i.e., a conservative amino acid substitution, resulting in a silent change that does not significantly affect the PHA synthase enzymatic activity of the protein.

Substitutes for an amino acid within the fundamental *R. rubrum* PHA synthase amino acid sequence can be selected from other members of the class to which the naturally occurring amino acid belongs. Amino acids can be divided into the following four groups: (1) acidic amino acids; (2) basic amino acids; (3) neutral polar amino acids; and (4) neutral non-polar amino acids. Representative amino acids within these various groups include, but are not limited to: (1) acidic (negatively charged) amino acids such as aspartic acid and glutamic acid; (2) basic (positively charged) amino acids such as arginine, histidine, and lysine; (3) neutral polar amino acids such as glycine, serine, threonine, cyteine, cystine, tyrosine, asparagine, and glutamine; and (4) neutral nonpolar (hydrophobic) amino acids such as alanine, leucine, isoleucine, valine, proline, phenylalanine, tryptophan, and methionine.

Conservative amino acid changes within the *R. rubrum* PHA synthase sequence can be made by substituting one amino acid within one of these groups with another amino acid within the same group. While biologically functional equivalents of *R. rubrum* PHA synthase can have any

number of conservative amino acid changes that do not significantly affect the PHA synthase enzymatic activity of this enzyme, 10 or fewer conservative amino acid changes may be preferred. More preferably, seven or fewer conservative amino acid changes may be preferred; most preferably, five or fewer conservative amino acid changes may be preferred. The encoding nucleotide sequence (gene, cDNA, synthetic DNA, or mRNA) will thus have corresponding base substitutions, permitting it to code on expression for the biologically functional equivalent form of *R. rubrum* PHA synthase.

The biologically functional equivalent peptides, polypeptides, and proteins of *R. rubrum* PHA synthase encompassed by the present invention should generally possess at least about 70% sequence similarity, preferably at least about 80% sequence similarity, and most preferably at least about 90% sequence similarity to the naturally occurring protein, or corresponding region or moiety thereof. In this context, "sequence similarity" is determined by the "Gap" or "BestFit" programs of the Sequence Analysis Software Package, Genetics Computer Group, Inc., University of Wisconsin Biotechnology Center, Madison, Wis. 53711. This software matches similar sequences by assigning degrees of homology to various additions, deletions, substitutions, and other modifications. BestFit makes an optimal alignment of the best segment of similarity between two sequences. Optimal alignments are found by inserting gaps to maximize the number of matches using the local homology algorithm of Smith and Waterman (1981) *Adv. Appl. Math.* 2:482-489. Gap uses the algorithm of Needleman and Wunsch (1970) *J. Mol. Biol.* 48:443-453) to find the alignment of two complete sequences that maximizes the number of matches and minimizes the number of gaps.

Fragments and Variants of *R. rubrum* PHA Synthase

Fragments and variants of *R. rubrum* PHA synthase possessing the same or similar PHA synthase enzymatic activity as that of *R. rubrum* PHA synthase are also encompassed by the present invention.

Fragments of *R. rubrum* PHA Synthase

Fragments of *R. rubrum* PHA synthase can be truncated forms of the enzyme wherein one or more amino acids are deleted from the N-terminal end, C-terminal end, internal region of the protein, or combinations thereof, so long as such fragments retain the same or similar PHA synthase enzymatic activity as the naturally occurring *R. rubrum* PHA synthase. These fragments can be naturally occurring mutants of PHA synthase, or can be produced by restriction endonuclease treatment or Exonuclease III treatment (Henikoff (1984) *Gene* 28:351) of the encoding nucleotide sequence.

Variants of *R. rubrum* PHA Synthase

Variants of *R. rubrum* PHA synthase include forms of the enzyme wherein one or more amino acids in the naturally occurring amino acid sequence has(have) been substituted with another amino acid, or wherein one or more amino acids has (have) been inserted into the natural amino acid sequence. The variants contemplated herein retain the same or similar PHA synthase enzymatic activity as naturally occurring *R. rubrum* PHA synthase. These variants can be naturally occurring mutants of PHA synthase, or can be produced by random mutagenesis of the wild-type encoding nucleotide sequence (Greener et al. (1994) *Strategies* 7:32-34) or by replacing domains thereof with domains of other PHA synthases of interest. The PHA synthase activity of such variants can be assayed enzymatically or by complementation as described supra.

Combinations of the foregoing, i.e., forms of *R. rubrum* PHA synthase containing amino acid additions, deletions, and substitutions, but which retain the same or similar PHA synthase enzymatic activity as naturally occurring *R. rubrum* PHA synthase, are also encompassed by the present invention.

Fragments and variants of *R. rubrum* PHA synthase encompassed by the present invention should preferably possess at least about 70% sequence similarity, more preferably at least about 80% sequence similarity, and most preferably at least about 90% sequence similarity, to the natural *R. rubrum* PHA synthase or corresponding region or moiety thereof. Sequence similarity can be determined using the Gap or BestFit programs of the Sequence Analysis Software Package discussed above.

EXAMPLE 5

Nucleotide Sequences Biologically Functionally Equivalent to Genomic DNA Encoding *R. rubrum* PHA Synthase

The present invention encompasses not only the *R. rubrum* genomic DNA sequence shown in SEQ ID NO:1, but also biologically functional equivalent nucleotide sequences. The phrase "biologically functional equivalent nucleotide sequences" denotes DNAs and RNAs, including genomic DNA, cDNA, synthetic DNA, and mRNA nucleotide sequences, that encode peptides, polypeptides, and proteins exhibiting the same or similar PHA synthase enzymatic activity as that of *R. rubrum* PHA synthase when assayed enzymatically or by complementation. Such biologically functional equivalent nucleotide sequences can encode peptides, polypeptides, and proteins that contain a region or moiety exhibiting sequence similarity to the corresponding region or moiety of the *R. rubrum* PHA synthase.

Nucleotide Sequences Encoding Conservative Amino Acid Changes in the *R. rubrum* PHA Synthase Amino Acid Sequence

As noted in Example 4, supra, biologically functional equivalent nucleotide sequences of the present invention include nucleotide sequences that encode conservative amino acid changes within the *R. rubrum* PHA synthase amino acid sequence, producing silent changes therein. Such nucleotide sequences thus contain corresponding base substitutions based upon the genetic code compared to wild-type nucleotide sequences encoding *R. rubrum* PHA synthase.

Nucleotide Sequences Encoding Non-Conservative Amino Acid Substitutions, Additions, or Deletions in *R. rubrum* PHA Synthase

In addition to nucleotide sequences encoding conservative amino acid changes within the naturally occurring *R. rubrum* PHA synthase amino acid sequence, biologically functional equivalent nucleotide sequences of the present invention also include genomic DNA, cDNA, synthetic DNA, and mRNA nucleotide sequences encoding non-conservative amino acid substitutions, additions, or deletions. These include nucleic acids that contain the same inherent genetic information as that contained in the genomic DNA of SEQ ID NO:1, and which encode peptides, polypeptides, or proteins exhibiting the same or similar PHA synthase enzymatic activity as that of *R. rubrum* PHA synthase. Such nucleotide sequences can encode fragments or variants of *R. rubrum* PHA synthase. The *R. rubrum* PHA

synthase-like enzymatic activity of such fragments and variants can be identified by complementation or enzymatic assays as described above. These biologically functional equivalent nucleotide sequences can possess at least 70% sequence identity, preferably at least 80% sequence identity, and most preferably at least 90% sequence identity, to naturally occurring *R. rubrum* PHA synthase genomic DNA, cDNA, synthetic DNA, and mRNA, respectively, or corresponding regions or moieties thereof.

Mutations made in *R. rubrum* PHA synthase cDNA, genomic DNA, synthetic DNA, mRNA, or other nucleic acid preferably preserve the reading frame of the coding sequence. Furthermore, these mutations preferably do not create complementary regions that could hybridize to produce secondary mRNA structures, such as loops or hairpins, that would adversely affect mRNA translation.

Although mutation sites can be predetermined, it is not necessary that the nature of the mutations per se be predetermined. For example, in order to select for optimum characteristics of mutants at a given site, site-directed mutagenesis can be conducted at the target codon (Thompson et al. (1988) *Biochemistry* 28:57335), and the PHA synthase enzymatic activity of the resulting peptide, polypeptide, or protein can be determined enzymatically or by complementation.

In the present invention, nucleic acids biologically functionally equivalent to *R. rubrum* PHA synthase genomic DNA having the nucleotide sequence shown in SEQ ID NO:1 include:

- (1) DNAs originating from *R. rubrum*, exemplified herein by *R. rubrum* ATCC 25903, the length of which has been altered either by natural or artificial mutations such as partial nucleotide insertion or deletion, or the like, so that when the entire length of the coding sequence within SEQ ID NO:1 is taken as 100%, the biologically functional equivalent nucleotide sequence has an approximate length of about 60–120% thereof, preferably about 80–110% thereof; or
- (2) nucleotide sequences containing partial (usually 20% or less, preferably 10% or less, more preferably 5% or less of the entire length) natural or artificial mutations so that such sequences code for different amino acids, but wherein the resulting protein retains the same or similar PHA synthase enzymatic activity as that of naturally occurring *R. rubrum* PHA synthase. The mutated DNAs created in this manner should preferably encode a protein having at least about 70%, preferably at least about 80%, and more preferably at least about 90%, sequence similarity to the amino acid sequence of the *R. rubrum* PHA synthase. Sequence similarity can be assessed by the Gap or BestFit programs of the Sequence Analysis Software Package discussed above.

The methods that can be employed to create the artificial nucleic acid mutations contemplated herein are not specifically limited, and can be produced by any of the means conventional in the art. For example, the *R. rubrum* PHA synthase gene, cDNA, or synthetic DNA can be treated with appropriate restriction enzymes so as to insert or delete desired DNA fragments so that the proper nucleic acid reading frame is preserved. Subsequent to restriction endonuclease treatment, the digested DNA can be treated to fill in any overhangs, and the DNA religated. C-terminal deletions can be produced by Exonuclease III treatment of the DNA. Alternatively, various domains of the *R. rubrum* PHA synthase can be replaced with regions of other PHA syn-

thases by appropriate nucleic acid manipulations employing restriction enzymes, followed by ligation.

Mutations can also be introduced at particular loci by synthesizing oligonucleotides containing a mutant sequence flanked by restriction sites enabling ligation to fragments of the native *R. rubrum* PHA synthase genomic DNA, cDNA, or synthetic DNA sequence. Following ligation, the resulting reconstructed sequence encodes a biologically functional equivalent having the desired amino acid insertion, substitution, or deletion.

Alternatively, oligonucleotide-directed site-specific or segment-specific mutagenesis procedures can be employed to produce an altered DNA sequence having particular codons altered according to the insertion, substitution, or deletion required.

Exemplary methods of making the alterations described above are disclosed by Walder et al. (1986) *Gene* 42:133; Bauer et al. (1985) *Gene* 37:73; Craik (January, 1985) *BioTechniques*, pp. 12–19; Smith et al. (1981) *Genetic Engineering: Principles and Methods*, Plenum Press; Ausubel et al. (1989) *Current Protocols in Molecular Biology*, John Wiley & Sons, Inc.; Sambrook et al. (1989) *Molecular Cloning: A Laboratory Manual*, Second Edition, Cold Spring Harbor Laboratory Press, Cold Spring Harbor, N.Y.; Frits Eckstein et al. (1982) *Nucleic Acids Research* 10:6487–6497, and Osuna et al. (1994) *Critical Reviews In Microbiology*, 20:107–116.

Biologically functional equivalents to the genomic DNA sequence disclosed herein produced by any of the foregoing methods can be selected for by complementation or enzymatic assay of the resulting peptides, polypeptides, or proteins as described above.

Alternatively, mutations can be introduced at particular loci by synthesizing oligonucleotides containing a mutant sequence flanked by restriction sites facilitating ligation to fragments of the native *R. rubrum* PHA synthase nucleotide sequence. Following ligation, the resulting reconstructed nucleotide sequence encodes a biologically functional equivalent form of synthase having the desired amino acid insertion, substitution, or deletion. The mutant forms so produced can be screened for *R. rubrum*-like PHA synthase activity by complementation or enzymatic assays.

Useful biologically functional equivalent forms of the genomic DNA of SEQ ID NO:1 include DNAs comprising nucleotide sequences that exhibit a level of sequence identity to corresponding regions or moieties of the genomic DNA of SEQ ID NO:1 of at least about 70%, preferably at least about 80%, and more preferably at least about 90%. Sequence identity can be determined using the BestFit or Gap programs discussed above.

Genetically Degenerate Nucleotide Sequences

Due to the degeneracy of the genetic code, i.e., the existence of more than one codon for most of the amino acids naturally occurring in proteins, genetically degenerate DNA (and RNA) sequences that contain the same essential genetic information as the genomic DNA of the present invention, and which encode the same amino acid sequence as that of *R. rubrum* PHA synthase, are encompassed by the present invention. Genetically degenerate forms of any of the other nucleic acid sequences discussed herein are encompassed by the present invention as well.

Biologically Functional Equivalent Nucleic Acid Sequences Detected by Hybridization

Although one embodiment of a nucleotide sequence encoding *R. rubrum* PHA synthase is shown in SEQ ID

NO:1, it should be understood that other biologically functional equivalent forms of *R. rubrum* PHA synthase-encoding nucleic acids can be readily isolated using conventional DNA-DNA or DNA-RNA hybridization techniques. Thus, the present invention also includes nucleotide sequences that hybridize to SEQ ID NO:1 and its complementary sequence, and that code on expression for peptides, polypeptides, and proteins exhibiting the same or similar enzymatic activity as that of *R. rubrum* PHA synthase. Such nucleotide sequences preferably hybridize to SEQ ID NO:1 or its complementary sequence under moderate to high stringency (see Sambrook et al. (1989) *Molecular Cloning: A Laboratory Manual*, Second Edition, Cold Spring Harbor Laboratory Press, Cold Spring Harbor, N.Y.). Exemplary conditions include initial hybridization in 6× SSC, 5× Denhardt's solution, 100 µg/ml fish sperm DNA, 0.1% SDS, at 55° C. for sufficient time to permit hybridization (e.g., several hours to overnight), followed by washing two times for 15 min. each in 2× SSC, 0.1% SDS, at room temperature, and two times for 15 min. each in 0.5–1× SSC, 0.1% SDS, at 55° C., followed by autoradiography. Typically, the nucleic acid molecule is capable of hybridizing when the hybridization mixture is washed at least one time in 0.1× SSC at 55° C., preferably at 60° C., and more preferably at 65° C.

The present invention also encompasses nucleotide sequences that hybridize to genomic DNA, cDNA, or synthetic DNA molecules that encode the amino acid sequence of *R. rubrum* PHA synthase, or genetically degenerate forms thereof due to the degeneracy of the genetic code, under salt and temperature conditions equivalent to those described supra, and that code on expression for a peptide, polypeptide, or protein that has the same or similar PHA synthase enzymatic activity as that of *R. rubrum* PHA synthase.

The nucleotide sequences described above are considered to possess a biological function substantially equivalent to that of the *R. rubrum* PHA synthase gene of the present invention if they encode peptides, polypeptides, or proteins having PHA synthase enzymatic activity differing from that of *R. rubrum* PHA synthase by about ±30% or less, preferably by about ±20% or less, and more preferably by about ±10% or less when assayed in vivo by complementation or by the enzymatic assays discussed above.

Biologically Functional Equivalent Nucleic Acid Sequences Detected by Complementation

An *E. coli* donor strain harboring a broad host range plasmid comprising a putative biologically functional equivalent nucleic acid in cis with all regulatory elements necessary for expression can be used to conjugate the plasmid into a recipient PHA-minus bacterial strain by triparental mating using the helper plasmid pRK2013 (Ditta et al. (1980) *Proc. Natl. Acad. Sci. USA* 77:7347). Resulting transconjugants can be selected on polymer-conductive medium supplemented with appropriate antibiotics. Fermentation of the transconjugants in media containing different carbon substrates and subsequent analysis of the resulting PHA provides a means of determining the functional equivalency of the nucleic acid.

Genomic Probes

In another aspect, the present invention provides oligonucleotide hybridization probes useful in screening genomic and other nucleic acid libraries for DNA sequences encoding peptides, polypeptides, or proteins having enzymatic activity the same or similar to that of *R. rubrum* PHA synthase, which probes can be designed based on the sequences provided in SEQ IDS NO:1–4. Especially useful probes, including degenerate probes, can be designed based on those regions that are highly conserved, or that show a high level of sequence similarity, among PHA synthases. Such probes can range from about 20 to about 60 nucleotides in length, generally about 20 nucleotides in length, more typically about 30 nucleotides in length, preferably about 40 nucleotides in length, and more preferably about 50–60 nucleotides in length. Preferably, these probes specifically hybridize to *R. rubrum* genomic DNA and other DNA sequences encoding peptides, polypeptides, or proteins having the same or similar PHA synthase enzymatic activity as that of *R. rubrum* PHA synthase under hybridization conditions such as those described above. Such oligonucleotide probes can be synthesized by automated synthesis, and can be conveniently labeled at the 5' end with a reporter molecule such as a radionuclide, e.g., ³²P, or biotin. The library to be probed can be plated as colonies or phage, depending upon the vector employed, and the recombinant DNA transferred to nylon or nitrocellulose membranes. Following denaturation, neutralization, and fixation of the DNA to the membrane, the membrane is hybridized with the labeled probe. Following this, the membrane is washed, and the reporter molecule detected. Colonies or phage harboring hybridizing DNA are then isolated and propagated. Candidate clones or PCR-amplified fragments can be verified as comprising DNA encoding *R. rubrum*-like PHA synthase activity or related peptides, polypeptides, or proteins having enzymatic activity the same as or similar to *R. rubrum* PHA synthase by a variety of methods. For example, the candidate clones can be hybridized with a second, non-overlapping probe, or subjected to DNA sequence analysis. The enzymatic activity of the peptide, polypeptide, or protein encoded thereby can be assessed by cloning and expression of the DNA in an appropriate host such as *E. coli*, followed by isolation of the peptide, polypeptide, or protein and assay of the enzymatic activity thereof. By such means, nucleic acids encoding PHA synthases from microorganisms other than *R. rubrum*, as well as peptides, polypeptides, and proteins biologically functionally equivalent to *R. rubrum* PHA synthase, useful in producing PHAs, can be isolated.

Degenerate Oligonucleotide Primers

Biologically functional equivalent PHA synthase genes from other microorganisms, or equivalent PHA synthase-encoding cDNAs or synthetic DNAs, can also be isolated by amplification using Polymerase Chain Reaction (PCR) methods. Degenerate oligonucleotide primers based on the amino acid sequence of *R. rubrum* PHA synthase can be prepared and used in conjunction with PCR technology employing reverse transcriptase (E. S. Kawasaki (1990), In Innis et al., Eds., *PCR Protocols*, Academic Press, San Diego, Chapter 3, p. 21) to amplify biologically functional equivalent DNAs from genomic or cDNA libraries of other organisms.

Alternatively, the degenerate oligonucleotides can be used as probes to screen cDNA libraries in, for example, λ phage vectors such as λ Zap.II (Stratagene).

EXAMPLE 6

Production of Polyhydroxyalkanoates in Bacteria and Plants Expressing the *R. rubrum* PHA Synthase

The PHA synthase-encoding DNA of *R. rubrum* can be introduced into and expressed in a variety of different

bacterial and plant host cells to facilitate the production of PHAs therein. It should be understood that reference to the *R. rubrum* PHA synthase and genomic DNA encoding the same in this context includes the biologically functional equivalents thereof, respectively, discussed above. The advantages of this approach to the production of PHAs include decreasing the dependence on petroleum-derived monomers, and the ease with which bacteria and plants can be grown on a large scale.

PHA synthesis in bacteria and plants requires at least three genes: β -ketothiolase (pha A), acetoacetyl-CoA reductase (phaB), and PHA synthase (phaC). Methods for incorporating these genes into transformation/expression vector constructs and introducing these constructs into bacterial and plant host cells to produce PHAs in such cells are well known in the art. Poirier et al. ((1995) *Bio/Technology* 13:142–150) have recently provided an extensive review of progress in this area. In general, such vector constructs comprise assemblies of DNA fragments operatively linked in a functional manner such that they drive the expression of the structural DNA sequences contained therein. These vector constructs usually contain a promoter that functions in the selected host cell, along with any other necessary regulatory regions such as ribosome binding sites, transcription terminators, 3' non-translated polyadenylation signals, etc., linked together in an operable manner, as well as selectable markers (Sambrook et al., *Molecular Cloning: A Laboratory Manual*, Second Edition, 1989, Cold Spring Harbor Laboratory Press, Cold Spring Harbor, N.Y.; Ausubel et al. (1989) *Current Protocols in Molecular Biology*, John Wiley & Sons, Inc.).

Such vectors can be introduced into bacterial cells by calcium chloride/heat shock treatment or electroporation. Transformed host cells can subsequently be selected for on selective media, cultured in an appropriate medium for a time and under conditions conducive to the production of PHA, and the PHA can then be recovered. Representative methods have been described by Slater et al. (1988) *J. Bacteriol.* 170:4431–4436; Slater et al. (1992) *Appl. Environ. Microbiol.* 58:1089–1094; Zhang et al. (1994) *Appl. Environ. Microbiol.* 60:1198–1205; and Kidwell et al. (1995) *Appl. Environ. Microbiol.* 61:1391–1398.

Particularly useful host bacteria for PHA polymer production employing the *R. rubrum* PHA synthase include *Alcaligenes* (e.g., *A. eutrophus*), *Escherichia coli*, *Klebsiella* (e.g., *K. aerogenes* and *K. oxytoca*), *Nocardia* (e.g., *N. corallina*), and *Pseudomonas* (e.g., *P. putida*).

In plants, transformation vectors capable of introducing bacterial genes involved in PHA biosynthesis are easily designed. Generally, such vectors comprise one or more coding sequences of interest under the transcriptional control of 5' and 3' regulatory sequences, including a promoter, and a selectable marker. Typical regulatory sequences include a transcription initiation start site, a ribosome binding site, an RNA processing signal, a transcription termination site, and/or a polyadenylation signal. Plant promoter sequences can be inducible or constitutive, environmentally- or developmentally-regulated, or cell- or tissue-specific. Often-used promoters include the CAMV 35S promoter, the enhanced CAMV 35S promoter, the nopaline synthase promoter, and the octopine synthase promoter. Representative vectors often comprise, operatively, linked in sequence in the 5' to 3' direction, a promoter sequence that directs the transcription of a downstream heterologous structural DNA in a plant; optionally, a non-translated leader sequence; a nucleotide sequence that encodes a protein of interest; and a 3' non-translated region that encodes a polyadenylation

signal which functions in plant cells to cause the termination of transcription and the addition of polyadenylate nucleotides to the 3' end of the mRNA encoding said protein.

A variety of different methods can be employed to introduce such vectors into plant protoplasts, cells, callus tissue, leaf discs, meristems, etc., to generate transgenic plants, including *Agrobacterium*-mediated transformation, particle gun delivery, microinjection, electroporation, polyethylene glycol-mediated protoplast transformation, liposome-mediated transformation, etc. (reviewed in Potrykus (1991) *Annu. Rev. Plant Physiol. Plant Mol. Biol.* 42:205–225). In general, transgenic plants comprising cells containing and expressing *R. rubrum* PHA synthase-encoding DNA can be produced by transforming plant cells with a DNA construct as described above via any of the foregoing methods; selecting plant cells that have been transformed on a selective medium; regenerating plant cells that have been transformed to produce differentiated plants; and selecting a transformed plant which expresses the *R. rubrum* PHA synthase-encoding nucleotide sequence.

The encoding DNAs can be introduced either in a single transformation event (all necessary DNAs present on the same vector), a co-transformation event (all necessary DNAs present on separate vectors that are introduced into plants or plant cells simultaneously), or by independent transformation events (all necessary DNAs present on separate vectors that are introduced into plants or plant cells independently). Traditional breeding methods can subsequently be used to incorporate the entire pathway into a single plant. Successful production of the PHA polyhydroxybutyrate in cells of *Arabidopsis* has been demonstrated by Poirier et al. (1992) *Science* 256:520–523, and in plastids thereof by Nawrath et al. (1994) *Proc. Natl. Acad. Sci. USA* 91:12760–12764.

Specific methods for transforming a wide variety of dicots and obtaining transgenic plants are well documented in the literature (see Gasser and Fraley (1989) *Science* 244:1293; Fisk and Dandekar (1993) *Scientia Horticulturae* 55:5–36; Christou (1994) *Agro Food Industry Hi Tech* (March/April 1994) p.17, and the references cited therein).

Successful transformation and plant regeneration have been achieved in the monocots as follows: asparagus (*Asparagus officinalis*; Bytebier et al. (1987) *Proc. Natl. Acad. Sci. USA* 84:5345); barley (*Hordeum vulgare*; Wan and Lemaux (1994) *Plant Physiol.* 104:37); maize (*Zea mays*; Rhodes et al. (1988) *Science* 240:204; Gordon-Kamm et al. (1990) *Plant Cell* 2:603; Fromm et al. (1990) *Bio/Technology* 8:833; Koziel et al. (1993) *Bio/Technology* 11:194); oats (*Avena sativa*; Somers et al. (1992) *Bio/Technology* 10:1589); orchardgrass (*Dactylis glomerata*; Horn et al. (1988) *Plant Cell Rep.* 7:469); rice (*Oryza sativa*, including indica and japonica varieties; Toriyama et al. (1988) *Bio/Technology* 6:10; Zhang et al. (1988) *Plant Cell Rep.* 7:379; Luo and Wu (1988) *Plant Mol. Biol. Rep.* 6:165; Zhang and Wu (1988) *Theor. Appl. Genet.* 76:835; Christou et al. (1991) *Bio/Technology* 9:957); rye (*Secale cereale*; De la Pena et al. (1987) *Nature* 325:274); sorghum (*Sorghum bicolor*; Casas et al. (1993) *Proc. Natl. Acad. Sci. USA* 90:11212); sugar cane (*Saccharum spp.*; Bower and Birch (1992) *Plant J.* 2:409); tall fescue (*Festuca arundinacea*; Wang et al. (1992) *Bio/Technology* 10:691); turfgrass (*Agrostis palustris*; Zhong et al. (1993) *Plant Cell Rep.* 13:1); and wheat (*Triticum aestivum*; Vasil et al. (1992) *Bio/Technology* 10:667; Troy Weeks et al. (1993) *Plant Physiol.* 102:1077; Becker et al. (1994) *Plant J.* 5:299).

Particularly useful plants for PHA polymer production include those, such as potato and sugarbeet, that produce

carbon substrates which can be employed for PHA biosynthesis. Cereal plants such as corn, wheat, and rice are also preferred. Other useful plants include tobacco and high oil seed plants such as soybean, canola, oil seed rape, and peanut. Plants that grow in desert or in mineralized soil are also preferred. Polymers that can be produced in this manner include PHB, and copolymers incorporating both short chain length and medium chain length monomers, such as PHB-co-PHV.

If the host plant of choice does not produce the requisite fatty acid substrates, appropriate β -ketothiolase and reduc-

tase genes can be introduced therein along with the *R. rubrum* PHA synthase. Host plants can also be modified, for example by mutagenesis, to block the glycerol ester and fatty acid degradation pathways so that they accumulate the appropriate substrates for PHA production.

The invention being thus described, it will be obvious that the same can be varied in many ways. Such variations are not to be regarded as a departure from the spirit and scope of the present invention, and all such modifications as would be obvious to one skilled in the art are intended to be included within the scope of the following claims.

SEQUENCE LISTING

(1) GENERAL INFORMATION:

(i i i) NUMBER OF SEQUENCES: 15

(2) INFORMATION FOR SEQ ID NO:1:

(i) SEQUENCE CHARACTERISTICS:

- (A) LENGTH: 1924 base pairs
- (B) TYPE: nucleic acid
- (C) STRANDEDNESS: double
- (D) TOPOLOGY: linear

(i x) FEATURE:

- (A) NAME/KEY: CDS
- (B) LOCATION: 8..1921

(x i) SEQUENCE DESCRIPTION: SEQ ID NO:1:

GAAGCCC	ATG	GGC	TTC	TTG	GCC	CTG	GAT	AAT	CTT	GAC	GCC	TAT	TTC	CGG	49	
	Met	Gly	Phe	Leu	Ala	Leu	Asp	Asn	Leu	Asp	Ala	Tyr	Phe	Arg		
	1				5					10						
GCC	GCG	AGC	CGC	CCC	ACC	GGA	TCG	CCT	GAC	CGC	CCT	TGG	TCA	GGC	CGA	97
Ala	Ala	Ser	Arg	Pro	Thr	Gly	Ser	Pro	Asp	Arg	Pro	Trp	Ser	Gly	Arg	
15					20					25					30	
CCG	TCC	GAA	CGG	GAG	GGA	AAG	ACC	ATG	ACC	GAC	ACG	CGG	GCC	GAA	GCC	145
Pro	Ser	Glu	Arg	Glu	Gly	Lys	Thr	Met	Thr	Asp	Thr	Arg	Ala	Glu	Ala	
				35						40				45		
GAC	TTA	ACC	GAG	GTT	TGG	CGG	GCC	TGG	GCG	GCC	TGG	GGC	GAG	AAA	AGC	193
Asp	Leu	Thr	Glu	Val	Trp	Arg	Ala	Trp	Ala	Ala	Trp	Gly	Glu	Lys	Ser	
			50					55					60			
CGG	ACG	ATG	TGG	GCA	ACG	GCC	CTG	GGC	GGC	GCG	GCG	CCC	CCC	TCT	TCC	241
Arg	Thr	Met	Trp	Ala	Thr	Ala	Leu	Gly	Gly	Ala	Ala	Pro	Pro	Ser	Ser	
		65					70					75				
CCA	TCC	CCC	TCG	GGG	CCC	GAC	CCG	GCC	GTT	GGG	GGC	GGC	CCG	GCC	GTC	289
Pro	Ser	Pro	Ser	Gly	Pro	Asp	Pro	Ala	Val	Gly	Gly	Gly	Pro	Ala	Val	
	80					85					90					
GGG	GGC	GAC	GCG	GCG	CGG	GCC	TTC	CTT	GAG	GGG	GTT	TTG	CGC	CCT	TCC	337
Gly	Gly	Asp	Ala	Ala	Arg	Ala	Phe	Leu	Glu	Gly	Val	Leu	Arg	Pro	Ser	
95					100					105					110	
CAA	CCC	GTT	CTG	GAC	GCC	CAG	GCG	GCC	TGG	GCC	CGC	GAT	ATC	GCG	GCG	385
Gln	Pro	Val	Leu	Asp	Ala	Gln	Ala	Ala	Trp	Ala	Arg	Asp	Ile	Ala	Ala	
				115					120					125		
CTG	TGT	CAG	GCC	GCC	GCT	AAA	CGG	CTG	CGG	GGC	GAA	GAG	GCG	GCG	CCG	433
Leu	Cys	Gln	Ala	Ala	Ala	Lys	Arg	Leu	Arg	Gly	Glu	Glu	Ala	Ala	Pro	
			130					135					140			
GTG	ATC	GAA	CCG	GCG	GGC	GAT	GAC	AAC	CGC	TTC	AAA	GAT	GAC	GCC	TGG	481
Val	Ile	Glu	Pro	Ala	Gly	Asp	Asp	Asn	Arg	Phe	Lys	Asp	Asp	Ala	Trp	
		145				150						155				
ACC	AAG	GAT	CCG	CTG	TTT	GAC	ACC	CTG	AAG	CAG	GGC	TAT	CTG	CTG	ACC	529
Thr	Lys	Asp	Pro	Leu	Phe	Asp	Thr	Leu	Lys	Gln	Gly	Tyr	Leu	Leu	Thr	
		160				165					170					

-continued

GCC Ala 175	CGG Arg	CTG Leu	GTC Val	GCC Ala	ACC Thr 180	ACC Thr	TTG Leu	GAA Glu	AAC Asn	AGC Ser 185	GGC Gly	GGC Gly	GAC Asp	CCG Pro	GCC Ala 190	577
TGC Cys	CGC Arg	CAG Gln	CGC Arg	CTC Leu 195	GCC Ala	TTT Phe	TAT Tyr	GGG Gly	CGT Arg 200	CAG Gln	GTG Val	GTC Val	GAC Asp	GCC Ala 205	CTC Leu	625
GCC Ala	CCG Pro	ACC Thr	AAT Asn 210	TTC Phe	GCC Ala	GCC Ala	ACC Thr	AAT Asn 215	CCG Pro	CTG Leu	GTT Val	CGG Arg	CGA Thr 220	ACC Thr	GCC Ala	673
CTA Leu	GAA Glu	AGC Ser 225	GGC Gly	GGC Gly	AAA Lys	AGC Ser	CTG Leu 230	TTG Leu	AAC Asn	GGG Gly	CTG Leu	GAA Glu 235	AAT Asn	CTG Leu	TTG Leu	721
CGC Arg	GAC Asp 240	CTG Leu	GAA Glu	CGC Arg	GGC Gly 245	GGC Gly	GGC Gly	CGG Arg	CTG Leu	CGC Arg	CCG Pro 250	ACG Thr	ATG Met	AGC Ser	GAT Asp	769
GAA Glu 255	ACC Thr	GCC Ala	TTC Phe	GAG Glu	GTT Val 260	GGT Gly	CGC Arg	ACC Thr	CTG Leu	GCC Ala 265	ATG Met	ACG Thr	CCG Pro	GGC Gly	AAG Lys 270	817
GTG Val	GTC Val	TTT Phe	CAA Gln	AAC Asn 275	GCC Ala	CTG Leu	ATG Met	CAG Gln	TTG Leu 280	ATC Ile	TTA Leu	TAT Tyr	GCG Ala	CCG Pro 285	ACC Thr	865
ACG Thr	CCG Pro	AAG Lys	GTC Val 290	CAC His	AAA Lys	CGG Arg	CCC Pro	TTG Leu 295	CTG Leu	GTG Val	GTG Val	CCG Pro	CCG Pro	TGG Trp 300	ATC Ile	913
AAT Asn	AAA Lys	TTC Phe 305	TAC Tyr	ATC Ile	CTG Leu	GAT Asp	CTG Leu 310	ACG Thr	GAA Glu	AAG Lys	AAC Asn	TCG Ser 315	CTG Leu	ATC Ile	AAA Lys	961
TAC Tyr 320	ATG Met	GTC Val	GAT Asp	CAG Gln	GGC Gly 325	TTC Phe	AGC Ser	GTG Val	TTC Phe	GTC Val	ATC Ile 330	TCC Ser	TGG Trp	GTC Val	AAC Asn	1009
CCC Pro 335	GAT Asp	GCC Ala	GGC Gly	TTG Leu	GCG Ala 340	GAA Glu	ACA Thr	CGC Arg	TTC Phe	GAG Glu 345	GAT Asp	TAC Tyr	CTC Leu	AGC Ser	CAG Gln 350	1057
GGG Gly	CCG Pro	CTG Leu	GCC Ala	GCC Ala 355	ATG Met	GAG Glu	GTG Val	ATG Met	ACC Thr 360	GAG Glu	ATC Ile	ACC Thr	GGC Gly	CAG Gln 365	CGC Arg	1105
GCT Ala	CTC Leu	GGA Gly	CTG Leu 370	GTC Val	GGC Gly	TAT Tyr	TGC Cys	ATC Ile 375	GGC Gly	GGC Gly	ACC Thr	CTG Leu	ACC Thr 380	GCC Ala	TGC Cys	1153
ACC Thr	CTG Leu	GCG Ala 385	GTA Val	CTG Leu	GCG Ala	GCG Ala	CGA Arg 390	CGG Arg	GAC Asp	CAT His	CGG Arg	GTG Val 395	AAA Lys	TCG Ser	GCC Ala	1201
ACC Thr 400	CTG Leu	CTT Leu	ACT Thr	ACC Thr	CTG Leu	GTC Val 405	GAT Asp	TTT Phe	TCC Ser	GAG Glu	CCG Pro 410	GGC Gly	GAG Glu	TTG Leu	GGC Gly	1249
GTT Val 415	TTC Phe	ATC Ile	GAC Asp	CCG Pro	CCC Pro 420	CTG Leu	CTT Leu	GAC Asp	GCC Ala	CTT Leu 425	GAC Asp	GAC Asp	CAG Gln	ATG Met	GCC Ala 430	1297
CGC Arg	GAC Asp	GGC Gly	GGG Gly	CTT Leu 435	GAC Asp	GGC Gly	GAC Asp	CTC Leu	TTG Leu 440	TCG Ser	ATG Met	GCC Ala	TTC Phe 445	AAC Asn	ATG Met	1345
CTG Leu	CGC Arg	GAC Asp	AAC Asn 450	GAC Asp	CTG Leu	ATC Ile	TGG Trp	TCG Ser 455	GTC Val	TTC Phe	ATC Ile	AAC Asn	AAC Asn 460	TAC Tyr	CTG Leu	1393
CTG Leu	GGC Gly	AAG Lys 465	ACC Thr	CCC Pro	GCC Ala	GCC Ala	TTC Phe 470	GAT Asp	CTG Leu	CTC Leu	TAT Tyr	TGG Trp 475	AAC Asn	GGC Gly	GAT Asp	1441
TCA Ser 480	ACG Thr	CGG Arg	ATG Met	CCC Pro	GCC Ala	GCC Ala 485	ATG Met	CAG Gln	CGT Arg	TAT Tyr	TAC Tyr	CTG Leu	CGC Arg	GAG Glu	ATG Met	1489

-continued

TAC Tyr 495	CAG Gln	AAG Lys	AAC Asn	AAG Lys	CTC Leu	GTC Val	CAG Gln	CCC Pro	GGC Gly	GGT Gly	CTG Leu	ACC Thr	GTG Val	CTT Leu	GGC Gly	1537
					500				505						510	
CAT His	GCC Ala	CTC Leu	GAC Asp	CTG Leu	CGG Arg	CGC Arg	ATT Ile	CGC Arg	ACC Thr	CCG Pro	GTT Val	TAT Tyr	CTT Leu	CTG Leu	TCG Ser	1585
				515					520					525		
GCC Ala	CGC Arg	GAC Asp	GAT Asp	CAC His	ATC Ile	GCG Ala	CCG Pro	TGG Trp	ACA Thr	AGC Ser	ACC Thr	TTC Phe	AAG Lys	GCC Ala	ACC Thr	1633
			530					535					540			
GGG Gly	CTT Leu	TAT Tyr	GGC Gly	GGA Gly	CCG Pro	CTG Leu	CGC Arg	TTC Phe	GTG Val	CTG Leu	GCG Ala	GGC Gly	AGC Ser	GGC Gly	CAT His	1681
		545					550					555				
ATC Ile	GCC Ala	GGG Gly	GTG Val	ATC Ile	AAC Asn	CCG Pro	CCG Pro	GCC Ala	AAG Lys	GCC Ala	CGC Arg	TAC Tyr	GGC Gly	TAT Tyr	TGG Trp	1729
	560					565					570					
ACC Thr	AAT Asn	GCG Ala	GAC Asp	ACC Thr	TCC Ser	CTG Leu	GAG Glu	GCC Ala	GAG Glu	TCC Ser	TGG Trp	CTA Leu	GAG Glu	GGC Gly	GCC Ala	1777
					580					585					590	
ACG Thr	CCC Pro	CAC His	GGG Gly	GGC Gly	TCC Ser	TGG Trp	TGG Trp	CCC Pro	GAT Asp	TGG Trp	GCG Ala	GCC Ala	TGG Trp	GCG Ala	GCC Ala	1825
				595					600					605		
GGT Gly	TAC Tyr	GCT Ala	GGC Gly	CCC Pro	AAA Lys	GTC Val	CCC Pro	GCC Ala	CGC Arg	GAC Asp	CCG Pro	ACC Thr	AAA Lys	GCC Ala	CCC Pro	1873
		610						615					620			
CGC Arg	CCG Pro	CCT Pro	TTG Leu	GAA Glu	GAC Asp	GCG Ala	CCG Pro	GGA Gly	TCT Ser	TAC Tyr	TTC Phe	AAG Lys	GTT Val	AGG Arg	ATC Ile	1921
		625					630					635				
TAA																1924

(2) INFORMATION FOR SEQ ID NO:2:

(i) SEQUENCE CHARACTERISTICS:

- (A) LENGTH: 638 amino acids
- (B) TYPE: amino acid
- (C) STRANDEDNESS:
- (D) TOPOLOGY: linear

(x i) SEQUENCE DESCRIPTION: SEQ ID NO:2:

Met Gly Phe Leu Ala Leu Asp Asn Leu Asp Ala Tyr Phe Arg Ala Ala
1 5 10 15

Ser Arg Pro Thr Gly Ser Pro Asp Arg Pro Trp Ser Gly Arg Pro Ser
20 25 30

Glu Arg Glu Gly Lys Thr Met Thr Asp Thr Arg Ala Glu Ala Asp Leu
35 40 45

Thr Glu Val Trp Arg Ala Trp Ala Ala Trp Gly Glu Lys Ser Arg Thr
50 55 60

Met Trp Ala Thr Ala Leu Gly Gly Ala Ala Pro Pro Ser Ser Pro Ser
65 70 75 80

Pro Ser Gly Pro Asp Pro Ala Val Gly Gly Gly Pro Ala Val Gly Gly
85 90 95

Asp Ala Ala Arg Ala Phe Leu Glu Gly Val Leu Arg Pro Ser Gln Pro
100 105 110

Val Leu Asp Ala Gln Ala Ala Trp Ala Arg Asp Ile Ala Ala Leu Cys
115 120 125

Gln Ala Ala Ala Lys Arg Leu Arg Gly Glu Glu Ala Ala Pro Val Ile
130 135 140

Glu Pro Ala Gly Asp Asp Asn Arg Phe Lys Asp Asp Ala Trp Thr Lys
145 150 155 160

-continued

Asp	Pro	Leu	Phe	Asp 165	Thr	Leu	Lys	Gln	Gly 170	Tyr	Leu	Leu	Thr	Ala 175	Arg
Leu	Val	Ala	Thr 180	Thr	Leu	Glu	Asn	Ser 185	Gly	Gly	Asp	Pro	Ala 190	Cys	Arg
Gln	Arg	Leu 195	Ala	Phe	Tyr	Gly	Arg 200	Gln	Val	Val	Asp	Ala 205	Leu	Ala	Pro
Thr	Asn 210	Phe	Ala	Ala	Thr	Asn 215	Pro	Leu	Val	Arg	Arg 220	Thr	Ala	Leu	Glu
Ser 225	Gly	Gly	Lys	Ser	Leu 230	Leu	Asn	Gly	Leu	Glu 235	Asn	Leu	Leu	Arg	Asp 240
Leu	Glu	Arg	Gly	Gly 245	Gly	Arg	Leu	Arg	Pro 250	Thr	Met	Ser	Asp	Glu 255	Thr
Ala	Phe	Glu	Val 260	Gly	Arg	Thr	Leu	Ala 265	Met	Thr	Pro	Gly	Lys 270	Val	Val
Phe	Gln	Asn 275	Ala	Leu	Met	Gln	Leu 280	Ile	Leu	Tyr	Ala	Pro 285	Thr	Thr	Pro
Lys 290	Val	His	Lys	Arg	Pro	Leu 295	Leu	Val	Val	Pro	Pro 300	Trp	Ile	Asn	Lys
Phe 305	Tyr	Ile	Leu	Asp	Leu 310	Thr	Glu	Lys	Asn	Ser 315	Leu	Ile	Lys	Tyr	Met 320
Val	Asp	Gln	Gly	Phe 325	Ser	Val	Phe	Val	Ile 330	Ser	Trp	Val	Asn	Pro 335	Asp
Ala	Gly	Leu	Ala 340	Glu	Thr	Arg	Phe	Glu 345	Asp	Tyr	Leu	Ser	Gln 350	Gly	Pro
Leu	Ala	Ala 355	Met	Glu	Val	Met	Thr 360	Glu	Ile	Thr	Gly	Gln 365	Arg	Ala	Leu
Gly	Leu 370	Val	Gly	Tyr	Cys	Ile 375	Gly	Gly	Thr	Leu	Thr 380	Ala	Cys	Thr	Leu
Ala 385	Val	Leu	Ala	Ala	Arg 390	Arg	Asp	His	Arg	Val 395	Lys	Ser	Ala	Thr	Leu 400
Leu	Thr	Thr	Leu	Val 405	Asp	Phe	Ser	Glu	Pro 410	Gly	Glu	Leu	Gly	Val 415	Phe
Ile	Asp	Pro	Pro 420	Leu	Leu	Asp	Ala	Leu 425	Asp	Asp	Gln	Met	Ala 430	Arg	Asp
Gly	Gly	Leu 435	Asp	Gly	Asp	Leu	Leu 440	Ser	Met	Ala	Phe	Asn 445	Met	Leu	Arg
Asp	Asn 450	Asp	Leu	Ile	Trp	Ser 455	Val	Phe	Ile	Asn	Asn 460	Tyr	Leu	Leu	Gly
Lys 465	Thr	Pro	Ala	Ala	Phe 470	Asp	Leu	Leu	Tyr	Trp 475	Asn	Gly	Asp	Ser	Thr 480
Arg	Met	Pro	Ala	Ala 485	Met	Gln	Arg	Tyr	Tyr 490	Leu	Arg	Glu	Met	Tyr	Gln 495
Lys	Asn	Lys	Leu 500	Val	Gln	Pro	Gly	Gly 505	Leu	Thr	Val	Leu	Gly 510	His	Ala
Leu	Asp	Leu 515	Arg	Arg	Ile	Arg	Thr 520	Pro	Val	Tyr	Leu	Leu 525	Ser	Ala	Arg
Asp	Asp 530	His	Ile	Ala	Pro	Trp 535	Thr	Ser	Thr	Phe	Lys 540	Ala	Thr	Gly	Leu
Tyr 545	Gly	Gly	Pro	Leu	Arg 550	Phe	Val	Leu	Ala	Gly 555	Ser	Gly	His	Ile	Ala 560
Gly	Val	Ile	Asn 565	Pro	Pro	Ala	Lys	Ala	Arg 570	Tyr	Gly	Tyr	Trp	Thr 575	Asn
Ala	Asp	Thr	Ser 580	Leu	Glu	Ala	Glu	Ser 585	Trp	Leu	Glu	Gly	Ala 590	Thr	Pro

-continued

His	Gly	Gly	Ser	Trp	Trp	Pro	Asp	Trp	Ala	Ala	Trp	Ala	Ala	Gly	Tyr
		595					600					605			
Ala	Gly	Pro	Lys	Val	Pro	Ala	Arg	Asp	Pro	Thr	Lys	Ala	Pro	Arg	Pro
	610					615					620				
Pro	Leu	Glu	Asp	Ala	Pro	Gly	Ser	Tyr	Phe	Lys	Val	Arg	Ile		
625					630					635					

(2) INFORMATION FOR SEQ ID NO:3:

(i) SEQUENCE CHARACTERISTICS:

(A) LENGTH: 600 amino acids

(B) TYPE: amino acid

(C) STRANDEDNESS:

(D) TOPOLOGY: linear

(x i) SEQUENCE DESCRIPTION: SEQ ID NO:3:

Met	Thr	Asp	Thr	Arg	Ala	Glu	Ala	Asp	Leu	Thr	Glu	Val	Trp	Arg	Ala
1				5					10					15	
Trp	Ala	Ala	Trp	Gly	Glu	Lys	Ser	Arg	Thr	Met	Trp	Ala	Thr	Ala	Leu
			20					25					30		
Gly	Gly	Ala	Ala	Pro	Pro	Ser	Ser	Pro	Ser	Pro	Ser	Gly	Pro	Asp	Pro
		35					40					45			
Ala	Val	Gly	Gly	Gly	Pro	Ala	Val	Gly	Gly	Asp	Ala	Ala	Arg	Ala	Phe
	50					55					60				
Leu	Glu	Gly	Val	Leu	Arg	Pro	Ser	Gln	Pro	Val	Leu	Asp	Ala	Gln	Ala
65					70					75				80	
Ala	Trp	Ala	Arg	Asp	Ile	Ala	Ala	Leu	Cys	Gln	Ala	Ala	Ala	Lys	Arg
			85						90					95	
Leu	Arg	Gly	Glu	Glu	Ala	Ala	Pro	Val	Ile	Glu	Pro	Ala	Gly	Asp	Asp
			100					105					110		
Asn	Arg	Phe	Lys	Asp	Asp	Ala	Trp	Thr	Lys	Asp	Pro	Leu	Phe	Asp	Thr
		115					120					125			
Leu	Lys	Gln	Gly	Tyr	Leu	Leu	Thr	Ala	Arg	Leu	Val	Ala	Thr	Thr	Leu
	130					135					140				
Glu	Asn	Ser	Gly	Gly	Asp	Pro	Ala	Cys	Arg	Gln	Arg	Leu	Ala	Phe	Tyr
145					150					155					160
Gly	Arg	Gln	Val	Val	Asp	Ala	Leu	Ala	Pro	Thr	Asn	Phe	Ala	Ala	Thr
				165					170					175	
Asn	Pro	Leu	Val	Arg	Arg	Thr	Ala	Leu	Glu	Ser	Gly	Gly	Lys	Ser	Leu
			180					185					190		
Leu	Asn	Gly	Leu	Glu	Asn	Leu	Leu	Arg	Asp	Leu	Glu	Arg	Gly	Gly	Gly
	195						200					205			
Arg	Leu	Arg	Pro	Thr	Met	Ser	Asp	Glu	Thr	Ala	Phe	Glu	Val	Gly	Arg
	210					215					220				
Thr	Leu	Ala	Met	Thr	Pro	Gly	Lys	Val	Val	Phe	Gln	Asn	Ala	Leu	Met
225					230					235					240
Gln	Leu	Ile	Leu	Tyr	Ala	Pro	Thr	Thr	Pro	Lys	Val	His	Lys	Arg	Pro
				245					250					255	
Leu	Leu	Val	Val	Pro	Pro	Trp	Ile	Asn	Lys	Phe	Tyr	Ile	Leu	Asp	Leu
			260					265					270		
Thr	Glu	Lys	Asn	Ser	Leu	Ile	Lys	Tyr	Met	Val	Asp	Gln	Gly	Phe	Ser
		275					280					285			
Val	Phe	Val	Ile	Ser	Trp	Val	Asn	Pro	Asp	Ala	Gly	Leu	Ala	Glu	Thr
	290					295					300				
Arg	Phe	Glu	Asp	Tyr	Leu	Ser	Gln	Gly	Pro	Leu	Ala	Ala	Met	Glu	Val
305					310					315					320

-continued

Met	Thr	Glu	Ile	Thr	Gly	Gln	Arg	Ala	Leu	Gly	Leu	Val	Gly	Tyr	Cys
				325					330					335	
Ile	Gly	Gly	Thr	Leu	Thr	Ala	Cys	Thr	Leu	Ala	Val	Leu	Ala	Ala	Arg
			340					345					350		
Arg	Asp	His	Arg	Val	Lys	Ser	Ala	Thr	Leu	Leu	Thr	Thr	Leu	Val	Asp
		355					360					365			
Phe	Ser	Glu	Pro	Gly	Glu	Leu	Gly	Val	Phe	Ile	Asp	Pro	Pro	Leu	Leu
	370					375					380				
Asp	Ala	Leu	Asp	Asp	Gln	Met	Ala	Arg	Asp	Gly	Gly	Leu	Asp	Gly	Asp
385					390					395					400
Leu	Leu	Ser	Met	Ala	Phe	Asn	Met	Leu	Arg	Asp	Asn	Asp	Leu	Ile	Trp
				405					410					415	
Ser	Val	Phe	Ile	Asn	Asn	Tyr	Leu	Leu	Gly	Lys	Thr	Pro	Ala	Ala	Phe
			420					425					430		
Asp	Leu	Leu	Tyr	Trp	Asn	Gly	Asp	Ser	Thr	Arg	Met	Pro	Ala	Ala	Met
		435					440					445			
Gln	Arg	Tyr	Tyr	Leu	Arg	Glu	Met	Tyr	Gln	Lys	Asn	Lys	Leu	Val	Gln
	450					455					460				
Pro	Gly	Gly	Leu	Thr	Val	Leu	Gly	His	Ala	Leu	Asp	Leu	Arg	Arg	Ile
465					470					475					480
Arg	Thr	Pro	Val	Tyr	Leu	Leu	Ser	Ala	Arg	Asp	Asp	His	Ile	Ala	Pro
				485					490					495	
Trp	Thr	Ser	Thr	Phe	Lys	Ala	Thr	Gly	Leu	Tyr	Gly	Gly	Pro	Leu	Arg
			500					505					510		
Phe	Val	Leu	Ala	Gly	Ser	Gly	His	Ile	Ala	Gly	Val	Ile	Asn	Pro	Pro
		515					520					525			
Ala	Lys	Ala	Arg	Tyr	Gly	Tyr	Trp	Thr	Asn	Ala	Asp	Thr	Ser	Leu	Glu
	530					535					540				
Ala	Glu	Ser	Trp	Leu	Glu	Gly	Ala	Thr	Pro	His	Gly	Gly	Ser	Trp	Trp
545					550					555					560
Pro	Asp	Trp	Ala	Ala	Trp	Ala	Ala	Gly	Tyr	Ala	Gly	Pro	Lys	Val	Pro
				565					570					575	
Ala	Arg	Asp	Pro	Thr	Lys	Ala	Pro	Arg	Pro	Pro	Leu	Glu	Asp	Ala	Pro
			580					585					590		
Gly	Ser	Tyr	Phe	Lys	Val	Arg	Ile								
		595					600								

(2) INFORMATION FOR SEQ ID NO:4:

- (i) SEQUENCE CHARACTERISTICS:
 (A) LENGTH: 574 amino acids
 (B) TYPE: amino acid
 (C) STRANDEDNESS:
 (D) TOPOLOGY: linear

(x i) SEQUENCE DESCRIPTION: SEQ ID NO:4:

Met	Trp	Ala	Thr	Ala	Leu	Gly	Gly	Ala	Ala	Pro	Pro	Ser	Ser	Pro	Ser
1				5					10					15	
Pro	Ser	Gly	Pro	Asp	Pro	Ala	Val	Gly	Gly	Gly	Pro	Ala	Val	Gly	Gly
			20					25					30		
Asp	Ala	Ala	Arg	Ala	Phe	Leu	Glu	Gly	Val	Leu	Arg	Pro	Ser	Gln	Pro
		35					40					45			
Val	Leu	Asp	Ala	Gln	Ala	Ala	Trp	Ala	Arg	Asp	Ile	Ala	Ala	Leu	Cys
	50					55					60				
Gln	Ala	Ala	Ala	Lys	Arg	Leu	Arg	Gly	Glu	Glu	Ala	Ala	Pro	Val	Ile
65					70					75					80

-continued

Glu	Pro	Ala	Gly	Asp 85	Asp	Asn	Arg	Phe	Lys 90	Asp	Asp	Ala	Trp	Thr 95	Lys
Asp	Pro	Leu	Phe 100	Asp	Thr	Leu	Lys	Gln 105	Gly	Tyr	Leu	Leu	Thr 110	Ala	Arg
Leu	Val	Ala 115	Thr	Thr	Leu	Glu	Asn 120	Ser	Gly	Gly	Asp	Pro 125	Ala	Cys	Arg
Gln 130	Arg	Leu	Ala	Phe	Tyr	Gly 135	Arg	Gln	Val	Val	Asp 140	Ala	Leu	Ala	Pro
Thr 145	Asn	Phe	Ala	Ala	Thr 150	Asn	Pro	Leu	Val	Arg 155	Arg	Thr	Ala	Leu	Glu 160
Ser	Gly	Gly	Lys	Ser 165	Leu	Leu	Asn	Gly	Leu 170	Glu	Asn	Leu	Leu	Arg	Asp 175
Leu	Glu	Arg	Gly 180	Gly	Gly	Arg	Leu	Arg 185	Pro	Thr	Met	Ser	Asp 190	Glu	Thr
Ala	Phe	Glu 195	Val	Gly	Arg	Thr	Leu 200	Ala	Met	Thr	Pro	Gly 205	Lys	Val	Val
Phe 210	Gln	Asn	Ala	Leu	Met	Gln 215	Leu	Ile	Leu	Tyr	Ala 220	Pro	Thr	Thr	Pro
Lys 225	Val	His	Lys	Arg	Pro 230	Leu	Leu	Val	Val	Pro 235	Pro	Trp	Ile	Asn	Lys 240
Phe	Tyr	Ile	Leu	Asp 245	Leu	Thr	Glu	Lys	Asn 250	Ser	Leu	Ile	Lys	Tyr	Met 255
Val	Asp	Gln	Gly 260	Phe	Ser	Val	Phe	Val 265	Ile	Ser	Trp	Val	Asn 270	Pro	Asp
Ala	Gly	Leu 275	Ala	Glu	Thr	Arg	Phe 280	Glu	Asp	Tyr	Leu	Ser 285	Gln	Gly	Pro
Leu 290	Ala	Ala	Met	Glu	Val	Met 295	Thr	Glu	Ile	Thr	Gly 300	Gln	Arg	Ala	Leu
Gly 305	Leu	Val	Gly	Tyr	Cys 310	Ile	Gly	Gly	Thr	Leu 315	Thr	Ala	Cys	Thr	Leu 320
Ala	Val	Leu	Ala	Ala 325	Arg	Arg	Asp	His	Arg 330	Val	Lys	Ser	Ala	Thr	Leu 335
Leu	Thr	Thr	Leu 340	Val	Asp	Phe	Ser	Glu 345	Pro	Gly	Glu	Leu	Gly 350	Val	Phe
Ile	Asp	Pro 355	Pro	Leu	Leu	Asp	Ala 360	Leu	Asp	Asp	Gln	Met 365	Ala	Arg	Asp
Gly	Gly 370	Leu	Asp	Gly	Asp	Leu 375	Leu	Ser	Met	Ala	Phe 380	Asn	Met	Leu	Arg
Asp 385	Asn	Asp	Leu	Ile	Trp 390	Ser	Val	Phe	Ile	Asn 395	Asn	Tyr	Leu	Leu	Gly 400
Lys	Thr	Pro	Ala	Ala 405	Phe	Asp	Leu	Leu	Tyr 410	Trp	Asn	Gly	Asp	Ser	Thr 415
Arg	Met	Pro	Ala 420	Ala	Met	Gln	Arg	Tyr 425	Tyr	Leu	Arg	Glu	Met 430	Tyr	Gln
Lys	Asn	Lys 435	Leu	Val	Gln	Pro	Gly 440	Gly	Leu	Thr	Val	Leu 445	Gly	His	Ala
Leu 450	Asp	Leu	Arg	Arg	Ile	Arg 455	Thr	Pro	Val	Tyr	Leu 460	Leu	Ser	Ala	Arg
Asp 465	Asp	His	Ile	Ala	Pro 470	Trp	Thr	Ser	Thr	Phe 475	Lys	Ala	Thr	Gly	Leu 480
Tyr	Gly	Gly	Pro	Leu 485	Arg	Phe	Val	Leu	Ala 490	Gly	Ser	Gly	His	Ile	Ala 495
Gly	Val	Ile	Asn	Pro	Pro	Ala	Lys	Ala	Arg	Tyr	Gly	Tyr	Trp	Thr	Asn

-continued

5 0 0					5 0 5					5 1 0					
Ala	Asp	Thr	Ser	Leu	Glu	Ala	Glu	Ser	Trp	Leu	Glu	Gly	Ala	Thr	Pro
		5 1 5					5 2 0					5 2 5			
His	Gly	Gly	Ser	Trp	Trp	Pro	Asp	Trp	Ala	Ala	Trp	Ala	Ala	Gly	Tyr
	5 3 0					5 3 5					5 4 0				
Ala	Gly	Pro	Lys	Val	Pro	Ala	Arg	Asp	Pro	Thr	Lys	Ala	Pro	Arg	Pro
	5 4 5					5 5 0					5 5 5				5 6 0
Pro	Leu	Glu	Asp	Ala	Pro	Gly	Ser	Tyr	Phe	Lys	Val	Arg	Ile		
				5 6 5					5 7 0						

(2) INFORMATION FOR SEQ ID NO:5:

(i) SEQUENCE CHARACTERISTICS:

(A) LENGTH: 589 amino acids

(B) TYPE: amino acid

(C) STRANDEDNESS:

(D) TOPOLOGY: linear

(x i) SEQUENCE DESCRIPTION: SEQ ID NO:5:

Met	Ala	Thr	Gly	Lys	Gly	Ala	Ala	Ala	Ser	Thr	Gln	Glu	Gly	Lys	Ser
1				5					10					15	
Gln	Pro	Phe	Lys	Val	Thr	Pro	Gly	Pro	Phe	Asp	Pro	Ala	Thr	Trp	Leu
			20					25					30		
Glu	Trp	Ser	Arg	Gln	Trp	Gln	Gly	Thr	Glu	Gly	Asn	Gly	His	Ala	Ala
		35					40					45			
Ala	Ser	Gly	Ile	Pro	Gly	Leu	Asp	Ala	Leu	Ala	Gly	Val	Lys	Ile	Ala
	50					55					60				
Pro	Ala	Gln	Leu	Gly	Asp	Ile	Gln	Gln	Arg	Tyr	Met	Lys	Asp	Phe	Ser
	65				70					75					80
Ala	Leu	Trp	Gln	Ala	Met	Ala	Glu	Gly	Lys	Ala	Glu	Ala	Thr	Gly	Pro
			85						90					95	
Leu	His	Asp	Arg	Arg	Phe	Ala	Gly	Asp	Ala	Trp	Arg	Thr	Asn	Leu	Pro
			100					105					110		
Tyr	Arg	Phe	Ala	Ala	Ala	Phe	Tyr	Leu	Leu	Asn	Ala	Arg	Ala	Leu	Thr
		115					120					125			
Glu	Leu	Ala	Asp	Ala	Val	Glu	Ala	Asp	Ala	Lys	Thr	Arg	Gln	Arg	Ile
	130					135					140				
Arg	Phe	Ala	Ile	Ser	Gln	Trp	Val	Asp	Ala	Met	Ser	Pro	Ala	Asn	Phe
	145				150					155					160
Leu	Ala	Thr	Asn	Pro	Glu	Ala	Gln	Arg	Leu	Leu	Ile	Glu	Ser	Gly	Gly
			165						170					175	
Glu	Ser	Leu	Arg	Ala	Gly	Val	Arg	Asn	Met	Met	Glu	Asp	Leu	Thr	Arg
			180					185					190		
Gly	Lys	Ile	Ser	Gln	Thr	Asp	Glu	Ser	Ala	Phe	Glu	Val	Gly	Arg	Asn
		195					200					205			
Val	Ala	Val	Thr	Glu	Gly	Ala	Val	Val	Phe	Glu	Asn	Glu	Tyr	Phe	Gln
	210					215					220				
Leu	Leu	Gln	Tyr	Lys	Pro	Leu	Thr	Asp	Lys	Val	His	Ala	Arg	Pro	Leu
	225				230					235					240
Leu	Met	Val	Pro	Pro	Cys	Ile	Asn	Lys	Tyr	Tyr	Ile	Leu	Asp	Leu	Gln
			245						250					255	
Pro	Glu	Ser	Ser	Leu	Val	Arg	His	Val	Val	Glu	Gln	Gly	His	Thr	Val
			260					265					270		
Phe	Leu	Val	Ser	Trp	Arg	Asn	Pro	Asp	Ala	Ser	Met	Ala	Gly	Ser	Thr
		275					280					285			
Trp	Asp	Asp	Tyr	Ile	Glu	His	Ala	Ala	Ile	Arg	Ala	Ile	Glu	Val	Ala

-continued

290				295				300							
Arg 305	Asp	Ile	Ser	Gly	Gln 310	Asp	Lys	Ile	Asn	Val 315	Leu	Gly	Phe	Cys	Val 320
Gly	Gly	Thr	Ile	Val 325	Ser	Thr	Ala	Leu	Ala 330	Val	Leu	Ala	Ala	Arg 335	Gly
Glu	His	Pro	Ala 340	Ala	Ser	Val	Thr	Leu 345	Leu	Thr	Thr	Leu	Leu 350	Asp	Phe
Ala	Asp	Thr 355	Gly	Ile	Leu	Asp	Val 360	Phe	Val	Asp	Glu	Gly 365	His	Val	Gln
Leu	Arg 370	Glu	Ala	Thr	Leu	Gly 375	Gly	Gly	Ala	Gly	Ala 380	Pro	Cys	Ala	Leu
Leu 385	Arg	Gly	Leu	Glu	Leu 390	Ala	Asn	Thr	Phe	Ser 395	Phe	Leu	Arg	Pro	Asn 400
Asp	Leu	Val	Trp	Asn 405	Tyr	Val	Val	Asp	Asn 410	Tyr	Leu	Lys	Gly	Asn 415	Thr
Pro	Val	Pro	Phe 420	Asp	Leu	Leu	Phe	Trp 425	Asn	Gly	Asp	Ala	Thr 430	Asn	Leu
Pro	Gly	Pro 435	Trp	Tyr	Cys	Trp	Tyr 440	Leu	Arg	His	Thr	Tyr 445	Leu	Gln	Asn
Glu	Leu 450	Lys	Val	Pro	Gly	Lys 455	Leu	Thr	Val	Cys	Gly 460	Val	Pro	Val	Asp
Leu 465	Ala	Ser	Ile	Asp	Val 470	Pro	Thr	Tyr	Ile	Tyr 475	Gly	Ser	Arg	Glu	Asp 480
His	Ile	Val	Pro	Trp 485	Thr	Ala	Ala	Tyr	Ala 490	Ser	Thr	Ala	Leu	Leu 495	Ala
Asn	Lys	Leu	Arg 500	Phe	Val	Leu	Gly	Ala 505	Ser	Gly	His	Ile	Ala 510	Gly	Val
Ile	Asn 515	Pro	Pro	Ala	Lys	Asn	Lys 520	Arg	Ser	His	Trp	Thr 525	Asn	Asp	Ala
Leu	Pro 530	Glu	Ser	Pro	Gln	Gln 535	Trp	Leu	Ala	Gly	Ala 540	Ile	Glu	His	His
Gly 545	Ser	Trp	Trp	Pro	Asp 550	Trp	Thr	Ala	Trp	Leu 555	Ala	Gly	Gln	Ala	Gly 560
Ala	Lys	Arg	Ala 565	Ala	Pro	Ala	Asn	Tyr	Gly 570	Asn	Ala	Arg	Tyr	Arg 575	Ala
Ile	Glu	Pro	Ala 580	Pro	Gly	Arg	Tyr	Val 585	Lys	Ala	Lys	Ala			

(2) INFORMATION FOR SEQ ID NO:6:

(i) SEQUENCE CHARACTERISTICS:

- (A) LENGTH: 604 amino acids
- (B) TYPE: amino acid
- (C) STRANDEDNESS:
- (D) TOPOLOGY: linear

(x i) SEQUENCE DESCRIPTION: SEQ ID NO:6:

Val 1	Gly	Thr	Glu	Arg 5	Thr	Asn	Pro	Ala	Ala 10	Pro	Asp	Phe	Glu	Thr 15	Ile
Ala	Arg	Asn	Ala 20	Asn	Gln	Leu	Ala	Glu 25	Val	Phe	Arg	Gln	Ser 30	Ala	Ala
Ala	Ser	Leu	Lys 35	Pro	Phe	Glu	Pro 40	Ala	Gly	Gln	Gly	Ala 45	Leu	Leu	Pro
Gly 50	Ala	Asn	Leu	Gln	Gly	Ala 55	Ser	Glu	Ile	Asp	Glu 60	Met	Thr	Arg	Thr
Leu	Thr	Arg	Val	Ala	Glu	Thr	Trp	Leu	Lys	Asp	Pro	Glu	Lys	Ala	Leu

-continued

65				70				75				80			
Gln	Ala	Gln	Thr	Lys ₈₅	Leu	Gly	Gln	Ser	Phe ₉₀	Ala	Ala	Leu	Trp	Ala ₉₅	Ser
Thr	Leu	Thr	Arg ₁₀₀	Met	Gln	Gly	Ala	Val ₁₀₅	Thr	Glu	Pro	Val	Val ₁₁₀	Gln	Pro
Pro	Pro	Thr ₁₁₅	Asp	Lys	Arg	Phe	Ala ₁₂₀	His	Ala	Asp	Trp	Ser ₁₂₅	Ala	Asn	Pro
Val	Phe ₁₃₀	Asp	Leu	Ile	Lys	Gln ₁₃₅	Ser	Tyr	Leu	Leu	Leu ₁₄₀	Gly	Arg	Trp	Ala
Glu ₁₄₅	Glu	Met	Val	Glu	Thr ₁₅₀	Ala	Glu	Gly	Ile	Asp ₁₅₅	Glu	His	Thr	Arg	His ₁₆₀
Lys	Ala	Glu	Phe	Tyr ₁₆₅	Leu	Arg	Gln	Leu	Leu ₁₇₀	Ser	Ala	Tyr	Ser	Pro ₁₇₅	Ser
Asn	Phe	Val	Met ₁₈₀	Thr	Asn	Pro	Glu	Leu ₁₈₅	Leu	Arg	Gln	Thr	Leu ₁₉₀	Glu	Glu
Gly	Gly	Ala ₁₉₅	Asn	Leu	Met	Arg	Gly ₂₀₀	Met	Lys	Met	Leu	Gln ₂₀₅	Glu	Asp	Leu
Glu	Ala ₂₁₀	Gly	Gly	Gly	Gln	Leu ₂₁₅	Arg	Val	Arg	Gln	Thr ₂₂₀	Asp	Leu	Ser	Ala
Phe ₂₂₅	Thr	Phe	Gly	Lys	Asp ₂₃₀	Val	Ala	Val	Thr	Pro ₂₃₅	Gly	Glu	Val	Ile	Phe ₂₄₀
Arg	Asn	Asp	Leu	Met ₂₄₅	Glu	Leu	Ile	Gln	Tyr ₂₅₀	Ala	Pro	Thr	Thr	Glu ₂₅₅	Thr
Val	Leu	Lys	Arg ₂₆₀	Pro	Leu	Leu	Ile	Val ₂₆₅	Pro	Pro	Trp	Ile	Asn ₂₇₀	Lys	Phe
Tyr	Ile	Leu ₂₇₅	Asp	Leu	Asn	Pro	Gln ₂₈₀	Lys	Ser	Leu	Ile	Gly ₂₈₅	Trp	Met	Val
Ser	Gln ₂₉₀	Gly	Ile	Thr	Val	Phe ₂₉₅	Val	Ile	Ser	Trp	Val ₃₀₀	Asn	Pro	Asp	Glu
Arg ₃₀₅	His	Arg	Asp	Lys	Asp ₃₁₀	Phe	Glu	Ser	Tyr	Met ₃₁₅	Arg	Glu	Gly	Ile	Glu ₃₂₀
Thr	Ala	Ile	Asp	Met ₃₂₅	Ile	Gly	Val	Ala	Thr ₃₃₀	Gly	Glu	Thr	Asp	Val ₃₃₅	Ala
Ala	Ala	Gly	Tyr ₃₄₀	Cys	Val	Gly	Gly ₃₄₅	Thr	Leu	Leu	Ala	Val	Thr ₃₅₀	Leu	Ala
Tyr	Gln	Ala ₃₅₅	Ala	Thr	Gly	Asn	Arg ₃₆₀	Arg	Ile	Lys	Ser	Ala ₃₆₅	Thr	Phe	Leu
Thr	Thr ₃₇₀	Gln	Val	Asp	Phe	Thr ₃₇₅	His	Ala	Gly	Asp	Leu ₃₈₀	Lys	Val	Phe	Ala
Asp ₃₈₅	Glu	Gly	Gln	Ile	Lys ₃₉₀	Ala	Ile	Glu	Glu	Arg ₃₉₅	Met	Ala	Glu	His	Gly ₄₀₀
Tyr	Leu	Glu	Gly	Ala ₄₀₅	Arg	Met	Ala	Asn	Ala ₄₁₀	Phe	Asn	Met	Leu	Arg ₄₁₅	Pro
Asn	Asp	Leu	Ile ₄₂₀	Trp	Ser	Tyr	Val	Val ₄₂₅	Asn	Asn	Tyr	Val	Arg ₄₃₀	Gly	Lys
Ala	Pro	Ala ₄₃₅	Ala	Phe	Asp	Leu	Leu ₄₄₀	Tyr	Trp	Asn	Ala	Asp ₄₄₅	Ala	Thr	Arg
Met	Pro ₄₅₀	Ala	Ala	Asn	His	Ser ₄₅₅	Phe	Tyr	Leu	Arg	Asn ₄₆₀	Cys	Tyr	Leu	Asn
Asn ₄₆₅	Thr	Leu	Ala	Lys	Gly ₄₇₀	Gln	Met	Val	Leu	Gly ₄₇₅	Asn	Val	Arg	Leu	Asp ₄₈₀
Leu	Lys	Lys	Val	Lys ₄₈₅	Val	Pro	Val	Phe	Asn ₄₉₀	Leu	Ala	Thr	Arg	Glu ₄₉₅	Asp

-continued

His	Ile	Ala	Pro	Ala	Leu	Ser	Val	Phe	Glu	Gly	Ser	Ala	Lys	Phe	Gly
			500					505					510		
Gly	Lys	Val	Asp	Tyr	Val	Leu	Ala	Gly	Ser	Gly	His	Ile	Ala	Gly	Val
		515					520					525			
Val	Ala	Pro	Pro	Gly	Pro	Lys	Ala	Lys	Tyr	Gly	Phe	Arg	Thr	Gly	Gly
	530					535					540				
Pro	Ala	Arg	Gly	Arg	Phe	Glu	Asp	Trp	Val	Ala	Ala	Ala	Thr	Glu	His
545					550					555					560
Pro	Gly	Ser	Trp	Trp	Pro	Tyr	Trp	Tyr	Lys	Trp	Leu	Glu	Glu	Gln	Ala
			565						570					575	
Pro	Glu	Arg	Val	Pro	Ala	Arg	Ile	Pro	Gly	Thr	Gly	Ala	Leu	Pro	Ser
			580					585					590		
Leu	Ala	Pro	Ala	Pro	Gly	Thr	Tyr	Val	Arg	Met	Lys				
		595					600								

(2) INFORMATION FOR SEQ ID NO:7:

- (i) SEQUENCE CHARACTERISTICS:
 (A) LENGTH: 559 amino acids
 (B) TYPE: amino acid
 (C) STRANDEDNESS:
 (D) TOPOLOGY: linear

(x i) SEQUENCE DESCRIPTION: SEQ ID NO:7:

Met	Ser	Gln	Lys	Asn	Asn	Asn	Glu	Leu	Pro	Lys	Gln	Ala	Ala	Glu	Asn
1				5					10					15	
Thr	Leu	Asn	Leu	Asn	Pro	Val	Ile	Gly	Ile	Arg	Gly	Lys	Asp	Leu	Leu
		20						25					30		
Thr	Ser	Ala	Arg	Met	Val	Leu	Leu	Gln	Ala	Val	Arg	Gln	Pro	Leu	His
		35					40					45			
Ser	Ala	Arg	His	Val	Ala	His	Phe	Ser	Leu	Glu	Leu	Lys	Asn	Val	Leu
	50					55					60				
Leu	Gly	Gln	Ser	Glu	Leu	Arg	Pro	Gly	Asp	Asp	Asp	Arg	Arg	Phe	Ser
65					70				75						80
Asp	Pro	Ala	Trp	Ser	Gln	Asn	Pro	Leu	Tyr	Lys	Arg	Tyr	Met	Gln	Thr
			85						90					95	
Tyr	Leu	Ala	Trp	Arg	Lys	Glu	Leu	His	Ser	Trp	Ile	Ser	His	Ser	Asp
			100					105					110		
Leu	Ser	Pro	Gln	Asp	Ile	Ser	Arg	Gly	Gln	Phe	Val	Ile	Asn	Leu	Leu
		115					120					125			
Thr	Glu	Ala	Met	Ser	Pro	Thr	Asn	Ser	Leu	Ser	Asn	Pro	Ala	Ala	Val
	130					135					140				
Lys	Arg	Phe	Phe	Glu	Thr	Gly	Gly	Lys	Ser	Leu	Leu	Asp	Gly	Leu	Gly
145					150				155						160
His	Leu	Ala	Lys	Asp	Leu	Val	Asn	Asn	Gly	Gly	Met	Pro	Ser	Gln	Val
				165					170					175	
Asp	Met	Asp	Ala	Phe	Glu	Val	Gly	Lys	Asn	Leu	Ala	Thr	Thr	Glu	Gly
			180					185					190		
Ala	Val	Val	Phe	Arg	Asn	Asp	Val	Leu	Glu	Leu	Ile	Gln	Tyr	Arg	Pro
		195					200					205			
Ile	Thr	Glu	Ser	Val	His	Glu	Arg	Pro	Leu	Leu	Val	Val	Pro	Pro	Gln
	210					215					220				
Ile	Asn	Lys	Phe	Tyr	Val	Phe	Asp	Leu	Ser	Pro	Asp	Lys	Ser	Leu	Ala
225					230					235					240
Arg	Phe	Cys	Leu	Arg	Asn	Gly	Val	Gln	Thr	Phe	Ile	Val	Ser	Trp	Arg
				245					250					255	

-continued

Asn	Pro	Thr	Lys 260	Ser	Gln	Arg	Glu	Trp 265	Gly	Leu	Thr	Thr	Tyr 270	Ile	Glu
Ala	Leu	Lys 275	Glu	Ala	Ile	Glu	Val 280	Val	Leu	Ser	Ile	Thr 285	Gly	Ser	Lys
Asp	Leu 290	Asn	Leu	Leu	Gly	Ala 295	Cys	Ser	Gly	Gly	Ile 300	Thr	Thr	Ala	Thr
Leu 305	Val	Gly	His	Tyr	Val 310	Ala	Ser	Gly	Glu	Lys 315	Lys	Val	Asn	Ala	Phe 320
Thr	Gln	Leu	Val	Ser 325	Val	Leu	Asp	Phe	Glu 330	Leu	Asn	Thr	Gln	Val 335	Ala
Leu	Phe	Ala	Asp 340	Glu	Lys	Thr	Leu	Glu 345	Ala	Ala	Lys	Arg	Arg 350	Ser	Tyr
Gln	Ser	Gly 355	Val	Leu	Glu	Gly	Lys 360	Asp	Met	Ala	Lys	Val 365	Phe	Ala	Trp
Met	Arg 370	Pro	Asn	Asp	Leu	Ile 375	Trp	Asn	Tyr	Trp	Val 380	Asn	Asn	Tyr	Leu
Leu 385	Gly	Asn	Gln	Pro	Pro 390	Ala	Phe	Asp	Ile	Leu 395	Tyr	Trp	Asn	Asn	Asp 400
Thr	Thr	Arg	Leu	Pro 405	Ala	Ala	Leu	His	Gly 410	Glu	Phe	Val	Glu	Leu 415	Phe
Lys	Ser	Asn	Pro 420	Leu	Asn	Arg	Pro	Gly 425	Ala	Leu	Glu	Val	Ser 430	Gly	Thr
Pro	Ile	Asp 435	Leu	Lys	Gln	Val	Thr 440	Cys	Asp	Phe	Tyr	Cys 445	Val	Ala	Gly
Leu 450	Asn	Asp	His	Ile	Thr	Pro 455	Trp	Glu	Ser	Cys	Tyr 460	Lys	Ser	Ala	Arg
Leu 465	Leu	Gly	Gly	Lys	Cys 470	Glu	Phe	Ile	Leu	Ser 475	Asn	Ser	Gly	His	Ile 480
Gln	Ser	Ile	Leu	Asn 485	Pro	Pro	Gly	Asn	Pro 490	Lys	Ala	Arg	Phe	Met 495	Thr
Asn	Pro	Glu	Leu	Pro	Ala	Glu	Pro	Lys 505	Ala	Trp	Leu	Glu	Gln 510	Ala	Gly
Lys	His	Ala 515	Asp	Ser	Trp	Trp	Leu 520	His	Trp	Gln	Gln	Trp 525	Leu	Ala	Glu
Arg	Ser 530	Gly	Lys	Thr	Arg	Lys 535	Ala	Pro	Ala	Ser	Leu 540	Gly	Asn	Lys	Thr
Tyr 545	Pro	Ala	Gly	Glu	Ala 550	Ala	Pro	Gly	Thr	Tyr 555	Val	His	Glu	Arg	

(2) INFORMATION FOR SEQ ID NO:8:

(i) SEQUENCE CHARACTERISTICS:

- (A) LENGTH: 560 amino acids
- (B) TYPE: amino acid
- (C) STRANDEDNESS:
- (D) TOPOLOGY: linear

(x i) SEQUENCE DESCRIPTION: SEQ ID NO:8:

Met	Arg	Glu	Lys	Gln	Glu	Ser	Gly	Ser	Val	Pro	Val	Pro	Ala	Glu	Phe
1				5					10					15	
Met	Ser	Ala	Gln	Ser	Ala	Ile	Val	Gly	Leu	Arg	Gly	Lys	Asp	Leu	Leu
			20					25					30		
Thr	Thr	Val	Arg	Ser	Leu	Ala	Val	His	Gly	Leu	Arg	Gln	Pro	Leu	His
		35					40					45			
Ser	Ala	Arg	His	Leu	Val	Ala	Phe	Gly	Gly	Gln	Leu	Gly	Lys	Val	Leu
	50					55					60				

-continued

Leu	Gly	Asp	Thr	Leu	His	Gln	Pro	Asn	Pro	Gln	Asp	Ala	Arg	Phe	Gln
65					70					75					80
Asp	Pro	Ser	Trp	Arg	Leu	Asn	Pro	Phe	Tyr	Arg	Arg	Thr	Leu	Gln	Ala
				85					90					95	
Tyr	Leu	Ala	Trp	Gln	Lys	Gln	Leu	Leu	Ala	Trp	Ile	Asp	Glu	Ser	Asn
			100					105					110		
Leu	Asp	Cys	Asp	Asp	Arg	Ala	Arg	Ala	Arg	Phe	Leu	Val	Ala	Leu	Leu
		115					120					125			
Ser	Asp	Ala	Val	Ala	Pro	Ser	Asn	Ser	Leu	Ile	Asn	Pro	Leu	Ala	Leu
	130					135					140				
Lys	Glu	Leu	Phe	Asn	Thr	Gly	Gly	Ile	Ser	Leu	Leu	Asn	Gly	Val	Arg
145					150					155					160
His	Leu	Leu	Glu	Asp	Leu	Val	His	Asn	Gly	Gly	Met	Pro	Ser	Gln	Val
				165					170					175	
Asn	Lys	Thr	Ala	Phe	Glu	Ile	Gly	Arg	Asn	Leu	Ala	Thr	Thr	Gln	Gly
			180					185					190		
Ala	Val	Val	Phe	Arg	Asn	Glu	Val	Leu	Glu	Leu	Ile	Gln	Tyr	Lys	Pro
		195					200					205			
Leu	Gly	Glu	Arg	Gln	Tyr	Ala	Lys	Pro	Leu	Leu	Ile	Val	Pro	Pro	Gln
	210					215					220				
Ile	Asn	Lys	Tyr	Tyr	Ile	Phe	Asp	Leu	Ser	Pro	Glu	Lys	Ser	Phe	Val
225					230					235					240
Gln	Tyr	Ala	Leu	Lys	Asn	Asn	Leu	Gln	Val	Phe	Val	Ile	Ser	Trp	Arg
				245					250					255	
Asn	Pro	Asp	Ala	Gln	His	Arg	Glu	Trp	Gly	Leu	Ser	Thr	Tyr	Val	Glu
			260					265					270		
Ala	Leu	Asp	Gln	Ala	Ile	Glu	Val	Ser	Arg	Glu	Ile	Thr	Gly	Ser	Arg
		275					280					285			
Ser	Val	Asn	Leu	Ala	Gly	Ala	Cys	Ala	Gly	Gly	Leu	Thr	Val	Ala	Ala
	290					295					300				
Leu	Leu	Gly	His	Leu	Gln	Val	Arg	Arg	Gln	Leu	Arg	Lys	Val	Ser	Ser
305					310					315					320
Val	Thr	Tyr	Leu	Val	Ser	Leu	Leu	Asp	Ser	Gln	Met	Glu	Ser	Pro	Ala
				325					330					335	
Met	Leu	Phe	Ala	Asp	Glu	Gln	Thr	Leu	Glu	Ser	Ser	Lys	Arg	Arg	Ser
			340					345					350		
Tyr	Gln	His	Gly	Val	Leu	Asp	Gly	Arg	Asp	Met	Ala	Lys	Val	Phe	Ala
		355					360					365			
Trp	Met	Arg	Pro	Asn	Asp	Leu	Ile	Trp	Asn	Tyr	Trp	Val	Asn	Asn	Tyr
	370					375					380				
Leu	Leu	Gly	Arg	Gln	Pro	Pro	Ala	Phe	Asp	Ile	Leu	Tyr	Trp	Asn	Asn
385					390					395					400
Asp	Asn	Thr	Arg	Leu	Pro	Ala	Ala	Phe	His	Gly	Glu	Leu	Leu	Asp	Leu
				405					410					415	
Phe	Lys	His	Asn	Pro	Leu	Thr	Arg	Pro	Gly	Ala	Leu	Glu	Val	Ser	Gly
			420					425					430		
Thr	Ala	Val	Asp	Leu	Gly	Lys	Val	Ala	Ile	Asp	Ser	Phe	His	Val	Ala
		435					440					445			
Gly	Ile	Thr	Asp	His	Ile	Thr	Pro	Trp	Asp	Ala	Val	Tyr	Arg	Ser	Ala
	450					455					460				
Leu	Leu	Leu	Gly	Gly	Gln	Arg	Arg	Phe	Ile	Leu	Ser	Asn	Ser	Gly	His
465					470					475					480
Ile	Gln	Ser	Ile	Leu	Asn	Pro	Pro	Gly	Asn	Pro	Lys	Ala	Cys	Tyr	Phe
				485					490					495	

-continued

Glu	Asn	Asp	Lys	Leu	Ser	Ser	Asp	Pro	Arg	Ala	Trp	Tyr	Tyr	Asp	Ala
			500					505					510		
Lys	Arg	Glu	Glu	Gly	Ser	Trp	Trp	Pro	Val	Trp	Leu	Gly	Trp	Leu	Gln
		515					520					525			
Glu	Arg	Ser	Gly	Glu	Leu	Gly	Asn	Pro	Asp	Phe	Asn	Leu	Gly	Ser	Ala
	530					535					540				
Ala	His	Pro	Pro	Leu	Glu	Ala	Ala	Pro	Gly	Thr	Tyr	Val	His	Ile	Arg
545					550					555					560

(2) INFORMATION FOR SEQ ID NO:9:

(i) SEQUENCE CHARACTERISTICS:

(A) LENGTH: 624 amino acids

(B) TYPE: amino acid

(C) STRANDEDNESS:

(D) TOPOLOGY: linear

(x i) SEQUENCE DESCRIPTION: SEQ ID NO:9:

Met	Ala	Ala	Pro	Arg	Ala	Gln	Ala	Ala	Ala	Pro	Ala	Gly	Thr	Gly	Gln
1				5					10					15	
Ser	Ala	Gly	Leu	Ala	Ala	Glu	Pro	His	Pro	Ala	Arg	Thr	Pro	Pro	Pro
			20					25					30		
Ser	Ser	Arg	Arg	Pro	Ser	Val	Pro	Ala	Ala	Ala	Ser	Gln	Gln	Leu	Ala
		35					40					45			
Gln	Asn	Ile	Glu	Arg	Ile	Glu	Ser	Leu	Thr	Gln	Arg	Leu	Ile	Ser	Ala
	50					55					60				
Leu	Ala	Gln	Arg	Arg	Pro	Ser	Asn	Pro	Gly	Val	Glu	Met	Pro	Gly	Pro
65					70					75					80
Asp	Leu	Phe	Ala	Thr	Ala	Thr	Ser	Ala	Trp	Ile	Lys	Leu	Leu	Ala	Glu
			85						90					95	
Gln	Pro	Glu	Arg	Val	Ile	Gly	Gln	Gln	Val	Ser	Tyr	Trp	Gly	Glu	Thr
			100					105					110		
Leu	Arg	His	Phe	Ala	Glu	Ala	Gln	Ala	Ala	Phe	Ala	Arg	Gly	Thr	Val
		115					120					125			
Thr	Pro	Pro	Pro	Ser	Glu	Gly	Pro	Arg	Asp	Arg	Arg	Phe	Ala	Asn	Pro
	130					135					140				
Leu	Trp	Glu	Ala	His	Pro	Phe	Phe	Asn	Phe	Ile	Lys	Arg	Gln	Tyr	Gln
145					150					155					160
Ile	Asn	Ala	Gln	Ala	Leu	Gln	Glu	Ala	Ala	Ser	Thr	Leu	Asp	Leu	Pro
			165						170					175	
Glu	Met	Thr	Asp	Arg	Arg	Arg	Ile	Glu	Trp	Phe	Thr	Arg	Gln	Met	Ile
			180					185					190		
Asp	Met	Met	Ala	Pro	Thr	Asn	Phe	Leu	Ala	Thr	Asn	Pro	Asp	Asp	Ser
		195					200					205			
Trp	Lys	Arg	Arg	Trp	Arg	Pro	Arg	Asp	Glu	Ser	Leu	Val	Arg	Gly	Leu
	210					215					220				
Glu	Asn	Leu	Val	Arg	Asp	Val	Glu	Gln	Asn	Ser	Gly	Glu	Leu	Ile	Val
225					230					235					240
Ser	Leu	Ala	Asp	Arg	Asp	Ala	Phe	Arg	Val	Gly	Glu	Asn	Ile	Gly	Thr
			245						250					255	
Thr	Glu	Gly	Thr	Val	Val	Ala	Arg	Thr	Lys	Leu	Tyr	Glu	Leu	Ile	Gln
			260					265					270		
Tyr	Lys	Pro	Thr	Thr	Ala	Gln	Val	His	Glu	Ile	Pro	Leu	Val	Ile	Phe
		275					280					285			
Pro	Pro	Trp	Ile	Asn	Lys	Phe	Tyr	Ile	Leu	Asp	Leu	Lys	Pro	Gln	Asn
	290					295					300				

-continued

Ser	Leu	Ile	Lys	Trp	Ile	Val	Asp	Gln	Gly	His	Thr	Leu	Phe	Val	Val
305					310					315					320
Ala	Trp	Lys	Asn	Pro	Asp	Pro	Ser	Tyr	Gly	Asp	Thr	Gly	Met	Asp	Asp
				325					330					335	
Tyr	Val	Ser	Ala	Tyr	Leu	Glu	Val	Met	Asp	Arg	Val	Leu	Asp	Leu	Thr
			340					345					350		
Asp	Gln	Lys	Lys	Leu	Asn	Ala	Val	Gly	Tyr	Cys	Ile	Ala	Gly	Thr	Thr
		355					360					365			
Leu	Ala	Leu	Thr	Pro	Val	Val	Leu	Lys	Gln	Arg	Gly	Asp	Asp	Arg	Val
	370					375					380				
Asn	Ala	Ala	Thr	Phe	Phe	Thr	Ala	Leu	Thr	Asp	Phe	Ala	Asp	Gln	Gly
385					390					395					400
Glu	Phe	Thr	Ala	Tyr	Leu	Gln	Glu	Asp	Phe	Val	Ser	Gly	Ile	Glu	Glu
				405					410					415	
Glu	Ala	Ala	Arg	Thr	Gly	Ile	Leu	Gly	Ala	Gln	Leu	Met	Thr	Arg	Thr
			420					425					430		
Phe	Ser	Phe	Leu	Arg	Ala	Asn	Asp	Leu	Val	Trp	Gly	Pro	Ala	Ile	Arg
		435					440					445			
Ser	Tyr	Met	Leu	Gly	Glu	Thr	Pro	Pro	Ala	Phe	Asp	Leu	Leu	Phe	Trp
	450					455					460				
Asn	Gly	Asp	Gly	Thr	Asn	Leu	Pro	Gly	Arg	Met	Ala	Val	Glu	Tyr	Leu
465					470					475					480
Arg	Gly	Leu	Cys	Gln	Gln	Asn	Arg	Phe	Val	Lys	Glu	Gly	Phe	Asp	Leu
				485					490					495	
Met	Gly	His	Arg	Leu	His	Val	Gly	Asp	Val	Thr	Val	Pro	Leu	Cys	Ala
			500					505					510		
Ile	Ala	Cys	Glu	Thr	Asp	His	Ile	Ala	Pro	Trp	Lys	Asp	Ser	Trp	Arg
		515					520					525			
Gly	Ile	Ala	Gln	Met	Gly	Ser	Arg	Asp	Lys	Thr	Phe	Ile	Leu	Ser	Glu
	530					535					540				
Ser	Gly	His	Ile	Ala	Gly	Ile	Val	Asn	Pro	Pro	Ser	Lys	Lys	Lys	Tyr
545					550					555					560
Gly	His	Tyr	Thr	Ser	Asp	Ala	Gly	Phe	Gly	Gln	Gly	Glu	Gln	His	Trp
				565					570					575	
Leu	Asp	Lys	Ala	Ser	His	His	Glu	Gly	Ser	Trp	Trp	Gly	Arg	Trp	Gly
			580					585					590		
Glu	Trp	Leu	Ala	Arg	Arg	Ala	Gly	Gly	Met	Val	Asp	Ala	Arg	Asp	Pro
		595					600					605			
Gly	Glu	Gly	Phe	Gly	Pro	Ala	Pro	Gly	Leu	Tyr	Val	His	Glu	Arg	Ala
	610					615					620				

(2) INFORMATION FOR SEQ ID NO:10:

- (i) SEQUENCE CHARACTERISTICS:
 (A) LENGTH: 559 amino acids
 (B) TYPE: amino acid
 (C) STRANDEDNESS:
 (D) TOPOLOGY: linear

(x i) SEQUENCE DESCRIPTION: SEQ ID NO:10:

Met	Ser	Asn	Lys	Asn	Asn	Asp	Glu	Leu	Gln	Arg	Gln	Ala	Ser	Glu	Asn
1				5					10					15	
Thr	Leu	Gly	Leu	Asn	Pro	Val	Ile	Gly	Ile	Arg	Arg	Lys	Asp	Leu	Leu
			20					25					30		
Ser	Ser	Ala	Arg	Thr	Val	Leu	Arg	Gln	Ala	Val	Arg	Gln	Pro	Leu	His
		35					40					45			

-continued

Ser	Ala	Lys	His	Val	Ala	His	Phe	Gly	Leu	Glu	Leu	Lys	Asn	Val	Leu
	50					55					60				
Leu	Gly	Lys	Ser	Ser	Leu	Ala	Pro	Glu	Ser	Asp	Asp	Arg	Arg	Phe	Asn
65					70					75					80
Asp	Pro	Ala	Trp	Ser	Asn	Asn	Pro	Leu	Tyr	Arg	Arg	Tyr	Leu	Gln	Thr
				85					90					95	
Tyr	Leu	Ala	Trp	Arg	Lys	Glu	Leu	Gln	Asp	Trp	Ile	Gly	Asn	Ser	Asp
			100					105					110		
Leu	Ser	Pro	Gln	Asp	Ile	Ser	Arg	Gly	Gln	Phe	Val	Ile	Asn	Leu	Met
		115					120					125			
Thr	Glu	Ala	Met	Ala	Pro	Thr	Asn	Thr	Leu	Ser	Asn	Pro	Ala	Ala	Val
	130					135					140				
Lys	Arg	Phe	Phe	Glu	Thr	Gly	Gly	Lys	Ser	Leu	Leu	Asp	Gly	Leu	Ser
145					150					155					160
Asn	Leu	Ala	Lys	Asp	Leu	Val	Asn	Asn	Gly	Gly	Met	Pro	Ser	Gln	Val
				165					170					175	
Asn	Met	Asp	Ala	Phe	Glu	Val	Gly	Lys	Asn	Leu	Gly	Thr	Ser	Glu	Gly
			180					185					190		
Ala	Val	Val	Tyr	Arg	Asn	Asp	Val	Leu	Glu	Leu	Ile	Gln	Tyr	Lys	Pro
		195					200					205			
Ile	Thr	Glu	Gln	Val	His	Ala	Arg	Pro	Leu	Leu	Val	Val	Pro	Pro	Gln
	210					215					220				
Ile	Asn	Lys	Phe	Tyr	Val	Phe	Asp	Leu	Ser	Pro	Glu	Lys	Ser	Leu	Ala
225					230					235					240
Arg	Tyr	Cys	Leu	Arg	Ser	Gln	Gln	Gln	Thr	Phe	Ile	Ile	Ser	Trp	Arg
				245					250					255	
Asn	Pro	Thr	Lys	Ala	Gln	Arg	Glu	Trp	Gly	Leu	Ser	Thr	Tyr	Ile	Asp
			260					265					270		
Ala	Leu	Lys	Glu	Ala	Val	Asp	Ala	Val	Leu	Ala	Ile	Thr	Gly	Ser	Lys
		275					280					285			
Asp	Leu	Asn	Met	Leu	Gly	Ala	Cys	Ser	Gly	Gly	Ile	Thr	Cys	Thr	Ala
	290					295					300				
Leu	Val	Gly	His	Tyr	Ala	Ala	Leu	Gly	Glu	Asn	Lys	Val	Asn	Ala	Leu
305					310					315					320
Thr	Leu	Leu	Val	Ser	Val	Leu	Asp	Thr	Thr	Met	Asp	Asn	Gln	Val	Ala
				325					330					335	
Leu	Phe	Val	Asp	Glu	Gln	Thr	Leu	Glu	Ala	Ala	Lys	Arg	His	Ser	Tyr
			340					345					350		
Gln	Ala	Gly	Val	Leu	Glu	Gly	Ser	Glu	Met	Ala	Lys	Val	Phe	Ala	Trp
		355					360					365			
Met	Arg	Pro	Asn	Asp	Leu	Ile	Trp	Asn	Tyr	Trp	Val	Asn	Asn	Tyr	Leu
	370					375					380				
Leu	Gly	Asn	Glu	Pro	Pro	Val	Phe	Asp	Ile	Leu	Phe	Trp	Asn	Asn	Asp
385					390					395					400
Thr	Thr	Arg	Leu	Pro	Ala	Ala	Phe	His	Gly	Asp	Leu	Ile	Glu	Met	Phe
				405					410					415	
Lys	Ser	Asn	Pro	Leu	Thr	Arg	Pro	Asp	Ala	Leu	Glu	Val	Cys	Gly	Thr
			420					425					430		
Pro	Ile	Asp	Leu	Lys	Gln	Val	Lys	Cys	Asp	Ile	Tyr	Ser	Leu	Ala	Gly
		435					440					445			
Thr	Asn	Asp	His	Ile	Thr	Pro	Trp	Gln	Ser	Cys	Tyr	Arg	Ser	Ala	His
	450					455					460				
Leu	Phe	Gly	Gly	Lys	Ile	Glu	Phe	Val	Leu	Ser	Asn	Ser	Gly	His	Ile

-continued

465				470				475				480			
Gln	Ser	Ile	Leu	Asn 485	Pro	Pro	Gly	Asn	Pro 490	Lys	Ala	Arg	Phe	Met	Thr 495
Gly	Ala	Asp	Arg 500	Pro	Gly	Asp	Pro	Val 505	Ala	Trp	Gln	Glu	Asn 510	Ala	Thr
Lys	His	Ala 515	Asp	Ser	Trp	Trp	Leu 520	His	Trp	Gln	Ser	Trp 525	Leu	Gly	Glu
Arg	Ala 530	Gly	Glu	Leu	Glu	Lys 535	Ala	Pro	Thr	Arg	Leu 540	Gly	Asn	Arg	Ala
Tyr 545	Ala	Ala	Gly	Glu	Ala 550	Ser	Pro	Gly	Thr	Tyr 555	Val	His	Glu	Arg	

(2) INFORMATION FOR SEQ ID NO:11:

(i) SEQUENCE CHARACTERISTICS:

- (A) LENGTH: 560 amino acids
- (B) TYPE: amino acid
- (C) STRANDEDNESS:
- (D) TOPOLOGY: linear

(x i) SEQUENCE DESCRIPTION: SEQ ID NO:11:

Met 1	Lys	Asp	Lys	Pro 5	Ala	Lys	Gly	Thr	Pro 10	Thr	Leu	Pro	Ala	Thr	Ser 15
Met	Asn	Val	Gln 20	Asn	Ala	Ile	Leu	Gly 25	Leu	Arg	Gly	Arg	Asp 30	Leu	Ile
Ser	Thr	Leu 35	Arg	Asn	Val	Ser	Arg 40	Gln	Ser	Leu	Arg	His 45	Pro	Leu	His
Thr	Ala 50	His	His	Leu	Leu	Ala 55	Leu	Gly	Gly	Gln	Leu 60	Gly	Arg	Val	Ile
Leu 65	Gly	Asp	Thr	Pro	Leu 70	Gln	Pro	Asn	Pro	Arg 75	Asp	Pro	Arg	Phe	Ser 80
Asp	Pro	Thr	Trp	Ser 85	Gln	Asn	Pro	Phe	Tyr 90	Arg	Arg	Gly	Leu	Gln 95	Ala
Tyr	Leu	Ala	Trp 100	Gln	Lys	Gln	Thr	Arg 105	Leu	Trp	Ile	Glu	Glu 110	Ser	His
Leu	Asp	Asp 115	Asp	Asp	Arg	Ala	Arg 120	Ala	His	Phe	Leu	Phe 125	Asn	Leu	Ile
Asn 130	Asp	Ala	Leu	Ala	Pro	Ser 135	Asn	Ser	Leu	Leu	Asn 140	Pro	Leu	Ala	Val
Lys 145	Glu	Leu	Phe	Asn	Ser 150	Gly	Gly	Gln	Ser	Leu 155	Val	Arg	Gly	Val	Ala 160
His	Leu	Leu	Asp	Asp 165	Leu	Arg	His	Asn	Asp 170	Gly	Leu	Pro	Arg	Gln 175	Val
Asp	Glu	Arg	Ala 180	Phe	Glu	Val	Gly	Gly 185	Asn	Leu	Ala	Ala	Thr 190	Ala	Gly
Ala	Val	Val 195	Phe	Arg	Asn	Glu	Leu 200	Leu	Glu	Leu	Ile	Gln 205	Tyr	Lys	Pro
Met 210	Ser	Glu	Lys	Gln	His	Ala 215	Arg	Pro	Leu	Leu	Val 220	Val	Pro	Pro	Gln
Ile 225	Asn	Lys	Phe	Tyr	Ile 230	Phe	Asp	Leu	Ser	Ser 235	Thr	Asn	Ser	Phe	Val 240
Gln	Tyr	Met	Leu	Lys 245	Asn	Gly	Leu	Gln	Val 250	Phe	Met	Val	Ser	Trp 255	Arg
Asn	Pro	Asp	Pro 260	Arg	His	Arg	Glu	Trp 265	Gly	Leu	Ser	Ser	Tyr 270	Val	Gln
Ala	Leu	Glu	Glu	Ala	Leu	Asn	Ala	Cys	Arg	Ser	Ile	Ser	Gly	Asn	Arg

-continued

275					280					285					
Asp	Pro	Asn	Leu	Met	Gly	Ala	Cys	Ala	Gly	Gly	Leu	Thr	Met	Ala	Ala
	290					295					300				
Leu	Gln	Gly	His	Leu	Gln	Ala	Lys	His	Gln	Leu	Arg	Arg	Val	Arg	Ser
305					310					315					320
Ala	Thr	Tyr	Leu	Val	Ser	Leu	Leu	Asp	Ser	Lys	Phe	Glu	Ser	Pro	Ala
				325					330					335	
Ser	Leu	Phe	Ala	Asp	Glu	Gln	Thr	Ile	Glu	Ala	Ala	Lys	Arg	Arg	Ser
			340					345					350		
Tyr	Gln	Arg	Gly	Val	Leu	Asp	Gly	Ala	Glu	Val	Ala	Arg	Ile	Phe	Ala
		355					360					365			
Trp	Met	Arg	Pro	Asn	Asp	Leu	Ile	Trp	Asn	Tyr	Trp	Val	Asn	Asn	Tyr
	370					375					380				
Leu	Leu	Gly	Lys	Thr	Pro	Pro	Ala	Phe	Asp	Ile	Leu	Tyr	Trp	Asn	Ala
385					390					395					400
Asp	Ser	Thr	Arg	Leu	Pro	Ala	Ala	Leu	His	Gly	Asp	Leu	Leu	Asp	Phe
				405					410					415	
Phe	Lys	Leu	Asn	Pro	Leu	Thr	His	Pro	Ala	Gly	Leu	Glu	Val	Cys	Gly
			420					425					430		
Thr	Pro	Ile	Asp	Leu	Gln	Lys	Val	Glu	Leu	Asp	Ser	Phe	Thr	Val	Ala
		435					440					445			
Gly	Ser	Asn	Asp	His	Ile	Thr	Pro	Trp	Asp	Ala	Val	Tyr	Arg	Ser	Ala
	450					455					460				
Leu	Leu	Leu	Gly	Gly	Asp	Arg	Arg	Phe	Val	Leu	Ala	Asn	Ser	Gly	His
465					470					475					480
Ile	Gln	Ser	Ile	Ile	Asn	Pro	Pro	Gly	Asn	Pro	Lys	Ala	Tyr	Tyr	Leu
				485					490					495	
Ala	Asn	Pro	Lys	Leu	Ser	Ser	Asp	Pro	Arg	Ala	Trp	Leu	His	Asp	Ala
			500					505					510		
Lys	Arg	Ser	Glu	Gly	Ser	Trp	Trp	Pro	Leu	Trp	Leu	Glu	Trp	Ile	Thr
		515					520					525			
Ala	Arg	Ser	Gly	Pro	Leu	Lys	Ala	Pro	Arg	Ser	Glu	Leu	Gly	Asn	Ala
	530					535					540				
Thr	Tyr	Pro	Pro	Leu	Gly	Pro	Ala	Pro	Gly	Thr	Tyr	Val	Leu	Thr	Arg
545					550					555					560

(2) INFORMATION FOR SEQ ID NO:12:

- (i) SEQUENCE CHARACTERISTICS:
 (A) LENGTH: 590 amino acids
 (B) TYPE: amino acid
 (C) STRANDEDNESS:
 (D) TOPOLOGY: linear

(x i) SEQUENCE DESCRIPTION: SEQ ID NO:12:

Met	Asn	Pro	Asn	Ser	Phe	Gln	Phe	Lys	Glu	Asn	Ile	Leu	Gln	Phe	Phe
1				5					10					15	
Ser	Val	His	Asp	Asp	Ile	Trp	Lys	Lys	Leu	Gln	Glu	Phe	Tyr	Tyr	Gly
			20					25					30		
Gln	Ser	Pro	Ile	Asn	Glu	Ala	Leu	Ala	Gln	Leu	Asn	Lys	Glu	Asp	Met
		35					40					45			
Ser	Leu	Phe	Phe	Glu	Ala	Leu	Ser	Lys	Asn	Pro	Ala	Arg	Met	Met	Glu
	50					55					60				
Met	Gln	Trp	Ser	Trp	Trp	Gln	Gly	Gln	Ile	Gln	Ile	Tyr	Gln	Asn	Val
65					70					75					80
Leu	Met	Arg	Ser	Val	Ala	Lys	Asp	Val	Ala	Pro	Phe	Ile	Gln	Pro	Glu

-continued

				85				90				95			
Ser	Gly	Asp	Arg	Arg	Phe	Asn	Ser	Pro	Leu	Trp	Gln	Glu	His	Pro	Asn
			100					105					110		
Phe	Asp	Leu	Leu	Ser	Gln	Ser	Tyr	Leu	Leu	Phe	Ser	Gln	Leu	Val	Gln
		115					120					125			
Asn	Met	Val	Asp	Val	Val	Glu	Gly	Val	Pro	Asp	Lys	Val	Arg	Tyr	Arg
	130					135					140				
Ile	His	Phe	Phe	Thr	Arg	Gln	Met	Ile	Asn	Ala	Leu	Ser	Pro	Ser	Asn
145					150					155					160
Phe	Leu	Trp	Thr	Asn	Pro	Glu	Val	Ile	Gln	Gln	Thr	Val	Ala	Glu	Gln
				165					170					175	
Gly	Glu	Asn	Leu	Val	Arg	Gly	Met	Gln	Val	Phe	His	Asp	Asp	Val	Met
			180					185					190		
Asn	Ser	Gly	Lys	Tyr	Leu	Ser	Ile	Arg	Met	Val	Asn	Ser	Asp	Ser	Phe
		195					200					205			
Ser	Leu	Gly	Lys	Asp	Leu	Ala	Tyr	Thr	Pro	Gly	Ala	Val	Val	Phe	Glu
	210					215					220				
Asn	Asp	Ile	Phe	Gln	Leu	Leu	Gln	Tyr	Glu	Ala	Thr	Thr	Glu	Asn	Val
225					230					235					240
Tyr	Gln	Thr	Pro	Ile	Leu	Val	Val	Pro	Pro	Phe	Ile	Asn	Lys	Tyr	Tyr
				245					250					255	
Val	Leu	Asp	Leu	Arg	Glu	Gln	Asn	Ser	Leu	Val	Asn	Trp	Leu	Arg	Gln
			260					265					270		
Gln	Gly	His	Thr	Val	Phe	Leu	Met	Ser	Trp	Arg	Asn	Pro	Asn	Ala	Glu
		275					280					285			
Gln	Lys	Glu	Leu	Thr	Phe	Ala	Asp	Leu	Ile	Thr	Gln	Gly	Ser	Val	Glu
	290					295					300				
Ala	Leu	Arg	Val	Ile	Glu	Glu	Ile	Thr	Gly	Glu	Lys	Glu	Ala	Asn	Cys
305					310					315					320
Ile	Gly	Tyr	Cys	Ile	Gly	Gly	Thr	Leu	Leu	Ala	Ala	Thr	Gln	Ala	Tyr
				325					330					335	
Tyr	Val	Ala	Lys	Arg	Leu	Lys	Asn	His	Val	Lys	Ser	Ala	Thr	Tyr	Met
			340					345					350		
Ala	Thr	Ile	Ile	Asp	Phe	Glu	Asn	Pro	Gly	Ser	Leu	Gly	Val	Phe	Ile
		355					360					365			
Asn	Glu	Pro	Val	Val	Ser	Gly	Leu	Glu	Asn	Leu	Asn	Asn	Gln	Leu	Gly
	370					375					380				
Tyr	Phe	Asp	Gly	Arg	Gln	Leu	Ala	Val	Thr	Phe	Ser	Leu	Leu	Arg	Glu
385					390					395					400
Asn	Thr	Leu	Tyr	Trp	Asn	Tyr	Tyr	Ile	Asp	Asn	Tyr	Leu	Lys	Gly	Lys
				405					410					415	
Glu	Pro	Ser	Asp	Phe	Asp	Ile	Leu	Tyr	Trp	Asn	Ser	Asp	Gly	Thr	Asn
			420					425					430		
Ile	Pro	Ala	Lys	Ile	His	Asn	Phe	Leu	Leu	Arg	Asn	Leu	Tyr	Leu	Asn
		435					440					445			
Asn	Glu	Leu	Ile	Ser	Pro	Asn	Ala	Val	Lys	Val	Asn	Gly	Val	Gly	Leu
	450					455					460				
Asn	Leu	Ser	Arg	Val	Lys	Thr	Pro	Ser	Phe	Phe	Ile	Ala	Thr	Gln	Glu
465					470					475					480
Asp	His	Ile	Ala	Leu	Trp	Asp	Thr	Cys	Phe	Arg	Gly	Ala	Asp	Tyr	Leu
				485					490					495	
Gly	Gly	Glu	Ser	Thr	Leu	Val	Leu	Gly	Glu	Ser	Gly	His	Val	Ala	Gly
			500					505					510		

-continued

Ile	Val	Asn 515	Pro	Pro	Ser	Arg	Asn 520	Lys	Tyr	Gly	Cys	Tyr 525	Thr	Asn	Ala
Ala	Lys 530	Phe	Glu	Asn	Thr	Lys 535	Gln	Trp	Leu	Asp	Gly 540	Ala	Glu	Tyr	His
Pro 545	Glu	Ser	Trp	Trp	Leu 550	Arg	Trp	Gln	Ala	Trp 555	Val	Thr	Pro	Tyr	Thr 560
Gly	Glu	Gln	Val	Pro 565	Ala	Arg	Asn	Leu	Gly 570	Asn	Ala	Gln	Tyr	Pro 575	Ser
Ile	Glu	Ala	Ala 580	Pro	Gly	Arg	Tyr	Val 585	Leu	Val	Asn	Leu	Phe 590		

(2) INFORMATION FOR SEQ ID NO:13:

(i) SEQUENCE CHARACTERISTICS:

- (A) LENGTH: 577 amino acids
- (B) TYPE: amino acid
- (C) STRANDEDNESS:
- (D) TOPOLOGY: linear

(x i) SEQUENCE DESCRIPTION: SEQ ID NO:13:

Met 1	Ala	Arg	Ala	Ala 5	Glu	Gln	Leu	Gly	Lys 10	Ala	Ala	Ser	Ala	Trp 15	Leu
Ala	Pro	Arg	Glu 20	Ala	Gly	Glu	Lys	Thr 25	Asp	Ser	Phe	Ala	Glu 30	Pro	Val
Ser	Asp 35	Met	Val	Lys	Thr	Leu	Ser 40	Lys	Val	Ser	Glu	Tyr 45	Trp	Leu	Ser
Asp 50	Pro	Arg	Arg	Thr	Leu	Glu 55	Ala	Gln	Thr	His	Leu 60	Leu	Gly	Ser	Phe
Phe 65	Asp	Met	Trp	Ser	Arg 70	Thr	Leu	Gln	Arg	Met 75	Ala	Ala	Asp	Ala	Val 80
Glu	Asp	Pro	Ala	Asn 85	Leu	Gln	His	Asn	Asp 90	Lys	Arg	Phe	Ala	Asp 95	Glu
Asp	Trp	Val	Lys 100	Asn	Pro	Phe	Phe	Asp 105	Phe	Ile	Arg	Gln	Ala 110	Tyr	Phe
Val	Thr	Ser 115	Asp	Trp	Ala	Glu	Arg 120	Met	Val	Lys	Asp	Ala 125	Glu	Gly	Leu
Asp 130	Asp	His	Thr	Arg	His	Lys 135	Ala	Ala	Phe	Tyr	Val 140	Arg	Gln	Ile	Ala
Ser 145	Ala	Leu	Ser	Pro	Thr 150	Asn	Phe	Ile	Thr	Thr 155	Asn	Pro	Gln	Leu	Tyr 160
Arg	Glu	Thr	Val	Ala 165	Ser	Ser	Gly	Ala	Asn 170	Leu	Val	Lys	Gly	Met 175	Gln
Met	Leu	Ala	Glu 180	Asp	Ile	Ala	Ala	Gly 185	Arg	Gly	Glu	Leu	Arg 190	Leu	Arg
Gln	Thr	Asp 195	Thr	Ser	Lys	Phe	Ala 200	Ile	Gly	Glu	Asn	Ile 205	Ala	Ile	Thr
Pro	Gly 210	Lys	Val	Ile	Ala	Gln 215	Asn	Asp	Val	Cys	Gln 220	Val	Leu	Gln	Tyr
Glu 225	Ala	Ser	Thr	Glu	Thr 230	Val	Leu	Lys	Arg	Pro 235	Leu	Leu	Ile	Cys	Pro 240
Pro	Trp	Ile	Asn	Lys 245	Phe	Tyr	Val	Leu	Asp 250	Leu	Asn	Pro	Glu	Lys 255	Ser
Phe	Ile	Lys	Trp 260	Ala	Val	Asp	Gln	Gly 265	Gln	Thr	Val	Phe	Val 270	Ile	Ser
Trp	Val	Asn 275	Pro	Asp	Glu	Arg	His 280	Ala	Ser	Lys	Asp	Trp 285	Glu	Ala	Tyr

-continued

Ala	Arg	Glu	Gly	Ile	Gly	Phe	Ala	Leu	Asp	Ile	Ile	Glu	Gln	Ala	Thr
	290					295					300				
Gly	Glu	Arg	Glu	Val	Asn	Ser	Ile	Gly	Tyr	Cys	Val	Gly	Gly	Thr	Leu
305					310					315					320
Leu	Ala	Ala	Thr	Leu	Ala	Leu	His	Ala	Ala	Glu	Gly	Asp	Glu	Arg	Ile
				325				330						335	
Arg	Ser	Ala	Thr	Leu	Phe	Thr	Thr	Gln	Val	Asp	Phe	Thr	His	Ala	Gly
			340					345					350		
Asp	Leu	Lys	Val	Phe	Val	Asp	Asp	Asp	Gln	Ile	Arg	His	Leu	Glu	Ala
		355					360					365			
Asn	Met	Ser	Ala	Thr	Gly	Tyr	Leu	Glu	Gly	Ser	Lys	Met	Ala	Ser	Ala
	370					375					380				
Phe	Asn	Met	Leu	Arg	Ala	Ser	Glu	Leu	Ile	Trp	Pro	Tyr	Phe	Val	Asn
385					390					395					400
Asn	Tyr	Leu	Lys	Gly	Gln	Asp	Pro	Leu	Pro	Phe	Asp	Leu	Leu	Tyr	Trp
			405						410					415	
Asn	Ser	Asp	Ser	Thr	Arg	Met	Pro	Ala	Ala	Asn	His	Ser	Phe	Tyr	Leu
			420					425					430		
Arg	Asn	Cys	Tyr	Leu	Glu	Asn	Arg	Leu	Ser	Arg	Gly	Glu	Met	Met	Leu
		435					440					445			
Ala	Gly	Arg	Arg	Val	Ser	Leu	Gly	Asp	Val	Lys	Ile	Pro	Ile	Tyr	Asn
	450					455					460				
Leu	Ala	Thr	Lys	Glu	Asp	His	Ile	Ala	Pro	Ala	Lys	Ser	Val	Phe	Leu
465					470					475					480
Gly	Ser	Ser	Ser	Phe	Gly	Gly	Lys	Val	Thr	Phe	Val	Leu	Ser	Gly	Ser
				485					490					495	
Gly	His	Ile	Ala	Gly	Val	Val	Asn	Pro	Pro	Ala	Arg	Ser	Lys	Tyr	Gln
			500					505					510		
Tyr	Trp	Thr	Gly	Gly	Ala	Pro	Lys	Gly	Asp	Ile	Glu	Thr	Trp	Met	Gly
		515					520					525			
Lys	Ala	Lys	Glu	Thr	Ala	Gly	Ser	Trp	Trp	Pro	His	Trp	Gln	Gly	Trp
	530					535					540				
Val	Glu	Arg	Leu	Asp	Lys	Arg	Arg	Val	Pro	Ala	Arg	Lys	Ala	Gly	Gly
545					550					555					560
Pro	Leu	Asn	Ser	Ile	Glu	Glu	Ala	Pro	Gly	Ser	Tyr	Val	Arg	Val	Arg
				565					570					575	
Ala															

(2) INFORMATION FOR SEQ ID NO:14:

- (i) SEQUENCE CHARACTERISTICS:
 (A) LENGTH: 561 amino acids
 (B) TYPE: amino acid
 (C) STRANDEDNESS:
 (D) TOPOLOGY: linear

(x i) SEQUENCE DESCRIPTION: SEQ ID NO:14:

Leu	Asp	His	Val	His	Lys	Lys	Leu	Lys	Ser	Thr	Leu	Asp	Pro	Ile	Gly
1				5					10					15	
Trp	Gly	Pro	Ala	Val	Thr	Ser	Val	Ala	Gly	Arg	Ala	Val	Arg	Asn	Pro
			20					25					30		
Gln	Ala	Val	Thr	Ala	Ala	Thr	Ala	Glu	Tyr	Ala	Gly	Arg	Leu	Ala	Lys
		35					40					45			
Ile	Pro	Ala	Ala	Ala	Thr	Arg	Val	Phe	Asn	Ala	Asn	Asp	Pro	Asp	Ala
	50					55					60				
Pro	Met	Pro	Val	Asp	Pro	Arg	Asp	Arg	Arg	Phe	Ser	Asp	Thr	Ala	Trp

-continued

65				70				75				80			
Gln	Glu	Asn	Pro	Ala ₈₅	Tyr	Phe	Ser	Leu	Leu ₉₀	Gln	Ser	Tyr	Leu	Ala ₉₅	Thr
Arg	Ala	Tyr	Val ₁₀₀	Glu	Glu	Leu	Thr	Glu ₁₀₅	Ala	Gly	Ser	Gly	Asp ₁₁₀	Pro	Leu
Gln	Asp	Gly ₁₁₅	Lys	Ala	Arg	Gln	Phe ₁₂₀	Ala	Asn	Leu	Met	Phe ₁₂₅	Asp	Ala	Leu
Ala	Pro	Ser	Asn	Phe	Leu	Trp ₁₃₅	Asn	Pro	Gly	Val	Leu ₁₄₀	Thr	Arg	Ala	Phe
Glu	Thr	Gly	Gly	Ala	Ser ₁₅₀	Leu	Leu	Arg	Gly	Ala ₁₅₅	Arg	Tyr	Ala	Ala	His ₁₆₀
Asp	Ile	Leu	Asn	Arg ₁₆₅	Gly	Gly	Leu	Pro	Leu ₁₇₀	Lys	Val	Asp	Ser	Asp ₁₇₅	Ala
Phe	Thr	Val	Gly ₁₈₀	Glu	Asn	Leu	Ala	Ala ₁₈₅	Thr	Pro	Gly	Lys	Val	Val ₁₉₀	Phe
Arg	Asn	Asp ₁₉₅	Leu	Ile	Glu	Leu	Ile ₂₀₀	Gln	Tyr	Ala	Pro	Gln ₂₀₅	Thr	Glu	Gln
Val	His ₂₁₀	Ala	Val	Pro	Ile	Leu ₂₁₅	Ala	Ala	Pro	Pro	Trp ₂₂₀	Ile	Asn	Lys	Tyr
Tyr	Ile	Leu	Asp	Leu	Ala ₂₃₀	Pro	Gly	Arg	Ser	Leu ₂₃₅	Ala	Glu	Trp	Ala	Val ₂₄₀
Gln	His	Gly	Arg	Thr ₂₄₅	Val	Phe	Met	Ile	Ser ₂₅₀	Tyr	Arg	Asn	Pro	Asp ₂₅₅	Glu
Ser	Met	Arg	His ₂₆₀	Ile	Thr	Met	Asp	Asp ₂₆₅	Tyr	Tyr	Val	Asp	Gly ₂₇₀	Ile	Ala
Thr	Ala	Leu ₂₇₅	Asp	Val	Val	Glu	Glu ₂₈₀	Ile	Thr	Gly	Ser	Pro ₂₈₅	Lys	Ile	Glu
Val	Leu ₂₉₀	Ser	Ile	Cys	Leu	Gly ₂₉₅	Gly	Ala	Met	Ala	Ala ₃₀₀	Met	Ala	Ala	Ala
Arg	Ala	Phe	Ala	Val	Gly ₃₁₀	Asp	Lys	Arg	Val	Ser ₃₁₅	Ala	Phe	Thr	Met	Leu ₃₂₀
Asn	Thr	Leu	Leu	Asp ₃₂₅	Tyr	Ser	Gln	Val	Gly ₃₃₀	Glu	Leu	Gly	Leu	Leu ₃₃₅	Thr
Asp	Pro	Ala	Thr ₃₄₀	Leu	Asp	Leu	Val	Glu ₃₄₅	Phe	Arg	Met	Arg	Gln ₃₅₀	Gln	Gly
Phe	Leu	Ser ₃₅₅	Gly	Lys	Glu	Met	Ala ₃₆₀	Gly	Ser	Phe	Asp	Met ₃₆₅	Ile	Arg	Ala
Lys	Asp ₃₇₀	Leu	Val	Phe	Asn	Tyr ₃₇₅	Trp	Val	Ser	Arg	Trp ₃₈₀	Met	Lys	Gly	Glu
Lys	Pro	Ala	Ala	Phe	Asp ₃₉₀	Ile	Leu	Ala	Trp	Asn ₃₉₅	Glu	Asp	Ser	Thr	Ser ₄₀₀
Met	Pro	Ala	Glu	Met ₄₀₅	His	Ser	His	Tyr	Leu ₄₁₀	Arg	Ser	Leu	Tyr	Gly ₄₁₅	Arg
Asn	Glu	Leu	Ala ₄₂₀	Glu	Gly	Leu	Tyr	Val ₄₂₅	Leu	Asp	Gly	Gln	Pro ₄₃₀	Leu	Asn
Leu	His	Asp ₄₃₅	Ile	Ala	Cys	Asp	Thr ₄₄₀	Tyr	Val	Val	Gly	Ala ₄₄₅	Ile	Asn	Asp
His	Ile ₄₅₀	Val	Pro	Trp	Thr	Ser ₄₅₅	Ser	Tyr	Gln	Ala	Val ₄₆₀	Asn	Leu	Leu	Gly
Gly	Asp	Val	Arg	Tyr	Val ₄₇₀	Leu	Thr	Asn	Gly	Gly ₄₇₅	His	Val	Ala	Gly	Ala ₄₈₀
Val	Asn	Pro	Pro	Gly ₄₈₅	Lys	Arg	Val	Trp	Phe ₄₉₀	Lys	Ala	Val	Gly	Ala	Pro ₄₉₅

-continued

Asp	Ala	Glu	Ser	Gly	Thr	Pro	Leu	Pro	Ala	Asp	Pro	Gln	Val	Trp	Asp
			500					505					510		
Glu	Ala	Ala	Thr	Arg	Tyr	Glu	His	Ser	Trp	Trp	Glu	Asp	Trp	Thr	Ala
		515					520					525			
Trp	Ser	Asn	Lys	Arg	Ala	Gly	Glu	Leu	Val	Ala	Pro	Pro	Ala	Met	Gly
	530					535					540				
Ser	Thr	Ala	His	Pro	Pro	Leu	Glu	Asp	Ala	Pro	Gly	Thr	Tyr	Val	Phe
545					550					555					560
Ser															

(2) INFORMATION FOR SEQ ID NO:15:

(i) SEQUENCE CHARACTERISTICS:

(A) LENGTH: 601 amino acids

(B) TYPE: amino acid

(C) STRANDEDNESS:

(D) TOPOLOGY: linear

(x i) SEQUENCE DESCRIPTION: SEQ ID NO:15:

Met	Ala	Thr	Glu	Glu	Gln	Ser	Pro	Gly	Ser	Gly	Arg	Asp	Ala	Gln	Phe
1				5					10					15	
Glu	Arg	Leu	Asn	Ala	Asn	Leu	Thr	Arg	Ile	Asp	Glu	Leu	Ser	Lys	Arg
			20					25					30		
Leu	Thr	Ala	Ala	Leu	Thr	Lys	Arg	Lys	Leu	Ser	Asp	Pro	Ala	Leu	His
		35					40					45			
Gly	Pro	Ser	Gly	Asp	Val	Phe	Leu	Lys	Ala	Met	Thr	Ala	Tyr	Met	Ala
	50					55					60				
Glu	Met	Met	Gln	Asn	Pro	Ala	Lys	Ile	Leu	Glu	His	Gln	Ile	Ser	Phe
65					70					75					80
Trp	Gly	Lys	Ser	Leu	Lys	His	Tyr	Val	Glu	Ala	Gln	His	Gln	Leu	Val
				85					90					95	
Lys	Gly	Glu	Leu	Lys	Pro	Pro	Pro	Asp	Val	Thr	Pro	Lys	Asp	Arg	Arg
			100					105					110		
Phe	Ser	Asn	Pro	Leu	Trp	Gln	Thr	His	Pro	Phe	Phe	Asn	Tyr	Leu	Lys
		115					120					125			
Gln	Gln	Tyr	Leu	Met	Asn	Ala	Glu	Ala	Val	Asn	Gln	Ala	Val	Glu	Gly
	130					135					140				
Leu	Glu	His	Ile	Glu	Pro	Ser	Asp	Lys	Lys	Arg	Val	Glu	Tyr	Phe	Ser
145					150					155					160
Arg	Gln	Ile	Val	Asp	Leu	Phe	Ser	Pro	Thr	Asn	Phe	Phe	Gly	Thr	Asn
				165					170					175	
Pro	Asp	Ala	Leu	Glu	Arg	Ala	Ile	Ala	Thr	Asp	Gly	Glu	Ser	Leu	Val
			180					185					190		
Gln	Gly	Leu	Glu	Asn	Leu	Val	Arg	Asp	Ile	Glu	Ala	Asn	Asn	Gly	Asp
		195					200					205			
Leu	Leu	Val	Thr	Leu	Ala	Asp	Pro	Glu	Ala	Phe	Gln	Val	Gly	Gln	Asn
	210					215					220				
Leu	Ala	Thr	Thr	Glu	Gly	Ser	Val	Val	Tyr	Arg	Asn	Arg	Met	Phe	Glu
225					230					235					240
Leu	Ile	Gln	Tyr	Lys	Pro	Thr	Thr	Glu	Thr	Val	His	Glu	Thr	Pro	Leu
				245					250					255	
Leu	Ile	Phe	Pro	Pro	Trp	Ile	Asn	Lys	Phe	Tyr	Ile	Leu	Asp	Leu	Lys
			260					265					270		
Pro	Gln	Asn	Ser	Leu	Leu	Lys	Trp	Leu	Val	Asp	Gln	Gly	Phe	Thr	Val
		275					280					285			
Phe	Val	Val	Ser	Trp	Val	Asn	Pro	Asp	Lys	Ser	Tyr	Ala	Gly	Ile	Gly

-continued

290				295				300							
Met 305	Asp	Asp	Tyr	Ile	Arg 310	Glu	Gly	Tyr	Met	Arg 315	Ala	Met	Ala	Glu	Val 320
Arg	Ser	Ile	Thr	Arg 325	Gln	Lys	Gln	Ile	Asn 330	Ala	Val	Gly	Tyr	Cys 335	Ile
Ala	Gly	Thr	Thr 340	Leu	Thr	Leu	Thr	Leu 345	Ala	His	Leu	Gln	Lys 350	Ala	Gly
Asp	Pro	Ser 355	Val	Arg	Ser	Ala	Thr 360	Phe	Phe	Thr	Thr	Leu 365	Thr	Asp	Phe
Ser	Asp 370	Pro	Gly	Glu	Val	Gly 375	Val	Phe	Leu	Asn	Asp 380	Asp	Phe	Val	Asp
Gly 385	Ile	Glu	Arg	Gln	Val 390	Ala	Val	Asp	Gly	Ile 395	Leu	Asp	Lys	Thr	Phe 400
Met	Ser	Arg	Thr	Phe 405	Ser	Tyr	Leu	Arg	Ser 410	Asn	Asp	Leu	Ile	Tyr 415	Gln
Pro	Ala	Ile	Lys 420	Ser	Tyr	Met	Met	Gly 425	Glu	Ala	Pro	Pro	Ala 430	Phe	Asp
Leu	Leu	Tyr 435	Trp	Asn	Gly	Asp	Gly 440	Thr	Asn	Leu	Pro	Ala 445	Gln	Met	Ala
Val	Glu 450	Tyr	Leu	Arg	Gly	Leu 455	Cys	Gln	Gln	Asp	Arg 460	Leu	Ala	Gly	Gly
Thr 465	Phe	Pro	Val	Leu	Gly 470	Ser	Pro	Val	Gly	Leu 475	Lys	Asp	Val	Thr	Leu 480
Pro	Val	Cys	Ala	Ile 485	Ala	Cys	Glu	Thr	Asp 490	His	Ile	Ala	Pro	Trp 495	Lys
Ser	Ser	Phe	Asn 500	Gly	Phe	Arg	Gln	Phe 505	Gly	Ser	Thr	Asp	Lys 510	Thr	Phe
Ile	Leu	Ser 515	Gln	Ser	Gly	His	Val 520	Ala	Gly	Ile	Val	Asn 525	Pro	Pro	Ser
Arg	Asn 530	Lys	Tyr	Gly	His	Tyr 535	Thr	Asn	Glu	Gly	Pro 540	Ala	Gly	Thr	Pro
Glu 545	Ser	Phe	Arg	Glu	Gly 550	Ala	Glu	Phe	His	Ala 555	Gly	Ser	Trp	Trp	Pro 560
Arg	Trp	Gly	Ala	Trp 565	Leu	Ala	Glu	Arg	Ser 570	Gly	Lys	Gln	Val	Pro 575	Ala
Arg	Gln	Pro	Gly 580	Asp	Ser	Lys	His	Pro 585	Glu	Leu	Ala	Pro	Ala 590	Pro	Gly
Ser	Tyr	Val 595	Ala	Ala	Val	Gly	Gly 600	Ala							

What is claimed is:

1. An isolated DNA molecule, comprising a nucleotide sequence elected from the group consisting of:

- (a) the nucleotide sequence of the coding strand shown in SEQ ID NO:1, or the complement thereof;
- (b) a nucleotide sequence that hybridizes to said nucleotide sequence of (a) under a wash stringency equivalent to 0.5× SSC to 2× SSC, 0.1% SDS, at 55°–65° C., and which encodes an enzyme having *Rhodospirillum rubrum* poly-β-hydroxyalkanoate synthase enzymatic activity;
- (c) a nucleotide sequence encoding the same genetic information as said nucleotide sequence of (a), but which is degenerate in accordance with the degeneracy of the genetic code; and

(d) a nucleotide sequence encoding the same genetic information as said nucleotide sequence of (b), but which is degenerate in accordance with the degeneracy of the genetic code.

2. The isolated DNA molecule of claim 1, wherein said wash stringency is equivalent to 2× SSC, 0.1% SDS, at 55° C.

3. The isolated DNA molecule of claim 1, wherein said wash stringency is equivalent to 1× SSC, 0.1% SDS, at 55° C.

4. The isolated DNA molecule of claim 1, wherein said wash stringency is equivalent to 0.5× SSC, 0.1% SDS, at 55° C.

5. An isolated DNA molecule, comprising the nucleotide sequence shown in SEQ ID NO:1.

6. A transformation vector comprising a DNA molecule according to claim 1.

65

- 7. A host cell containing a transformation vector according to claim 6.
- 8. The host cell of claim 7, which is a bacterial cell.
- 9. The host cell of claim 7, which is a plant cell.

66

- 10. A transgenic plant comprising plant cells according to claim 9.

* * * * *