

September 1959

# A New Grain Hardness Tester

Robert Katz

*University of Nebraska-Lincoln, rkatz2@unl.edu*

A. B. Cardwell

*Kansas Agricultural Experiment Station, Manhattan*

N. D. Collins

*Kansas Agricultural Experiment Station, Manhattan*

A. D. Hostetter

*Kansas Agricultural Experiment Station, Manhattan*

Follow this and additional works at: <http://digitalcommons.unl.edu/physicskatz>



Part of the [Physics Commons](#)

---

Katz, Robert; Cardwell, A. B.; Collins, N. D.; and Hostetter, A. D., "A New Grain Hardness Tester" (1959). *Robert Katz Publications*. 106.

<http://digitalcommons.unl.edu/physicskatz/106>

This Article is brought to you for free and open access by the Research Papers in Physics and Astronomy at DigitalCommons@University of Nebraska - Lincoln. It has been accepted for inclusion in Robert Katz Publications by an authorized administrator of DigitalCommons@University of Nebraska - Lincoln.

# CEREAL CHEMISTRY

VOL. 36

SEPTEMBER, 1959

No. 5

## A NEW GRAIN HARDNESS TESTER<sup>1</sup>

R. KATZ, A. B. CARDWELL, N. D. COLLINS,<sup>2</sup> and A. E. HOSTETTER<sup>3</sup>

### ABSTRACT

A hardness tester, especially adapted for grain, was constructed by modifying a commercial portable soft metal tester known as the Barcol Impressor. A preloaded stylus is forced into grain sections prepared by means of a microtome. The displacement of the stylus, measured by a dial micrometer, is used as a hardness index. This has been related to the Vickers diamond pyramid hardness which is a standard metallurgical test. A number of hardness measurements may be made on a single transverse kernel section. The tester may be used for all wheat varieties. Significant variations in hardness within a single wheat kernel section have been demonstrated. While the hardness of a block of lead varied over  $\pm 1/2$  hardness number, a kernel section of hard winter (Ponca) wheat exhibited hardness numbers ranging from 25 to 40, on the arbitrary scale of this tester.

Such terms as *hardness* and *vitreousness* have long been used to describe properties of grain of interest to wheat breeders and millers. Biting or cutting grain has provided a qualitative evaluation of this property. A number of attempts have been made to find a quantitative measure of the hardness of individual kernels or of the average hardness of a collection of kernels.

The Smetar hardness tester, produced by Miag, utilizes the penetration of a diamond-shaped stylus into a section of a kernel as a measure of hardness (4). The impression in the endosperm is measured with a microscope. This apparatus is similar in conception to the Vickers hardness tester used in metallurgy, except that the stylus of the Smetar tester is larger. That is necessary, for the impression made in a wheat kernel section by a Vickers tester is difficult to measure with the microscope attached to the Vickers machine. As a result of the size of its stylus, essentially only one or two measurements can be made on a wheat kernel section with the Smetar tester.

A traditional method for measuring the hardness of bulk samples

<sup>1</sup> Manuscript received October 27, 1958. Contribution No. 69, Department of Physics, Kansas Agricultural Experiment Station, Manhattan.

<sup>2</sup> Department of Physics.

<sup>3</sup> Department of Industrial Engineering.

is the laboratory-scale barley pearler (2). The fraction of a small sample of wheat which is pearled off in a short interval by an abrasive stone is used as a hardness index.

Another index of hardness which has been used is the energy required to mill 1 g. of grain. The Brabender hardness tester, which consists essentially of a small burr mill fitted to the dynamometer coupling of the Farinograph, has been used by Paukner (3). Basically this device measures the torque required to drive the burr mill as a small sample of grain is milled. The data are then reduced to terms of the energy required per milled gram of grain.

In the present work, the penetration of a small spring-loaded stylus into a kernel section is used as the basis of hardness measurement. A commercial portable hardness tester called the Barcol Impressor (manufactured by the Barber-Colman Co., Rockford, Illinois) has been adapted for work with grain by suitable choice of the stylus tip and of the spring loading. It has been possible to produce one model of the tester which is capable of 30 or more independent hardness measurements on a single wheat kernel section of hard wheat varieties. By increasing the radius of the stylus tip a second, more versatile model of the tester has been developed which is applicable to all wheat varieties under a wide range of ambient humidity. Approximately six independent measurements of the hardness of a single transverse kernel section may be made.

#### **Conversion of the Barcol Impressor into a Hardness Tester Suitable for Testing Wheat Sections**

The Barcol Impressor is a portable hardness tester designed for testing soft metals. The tester consists essentially of a spring-loaded stylus, a case, and a dial micrometer. Hardness is measured by the distance the stylus is displaced into the case when the tester is pressed against a test object. The greater the displacement of the stylus, the harder the object. Readings of the micrometer are referred to as hardness numbers. Adjustments are provided for setting the initial compression of the spring, and for setting the reading of the micrometer at its greatest deflection. The dial micrometer provided with the instrument has 100 divisions.

For work with wheat, several modifications of the Impressor were necessary. To provide a means of mounting and positioning a wheat kernel, the Impressor and a two-way microscope stage were mounted on an oak platform. Kernel sections, cemented to microscope slides, could then be set into place and located to 0.1 mm. by the Vernier scale of the microscope stage. A photograph of the modified Impressor

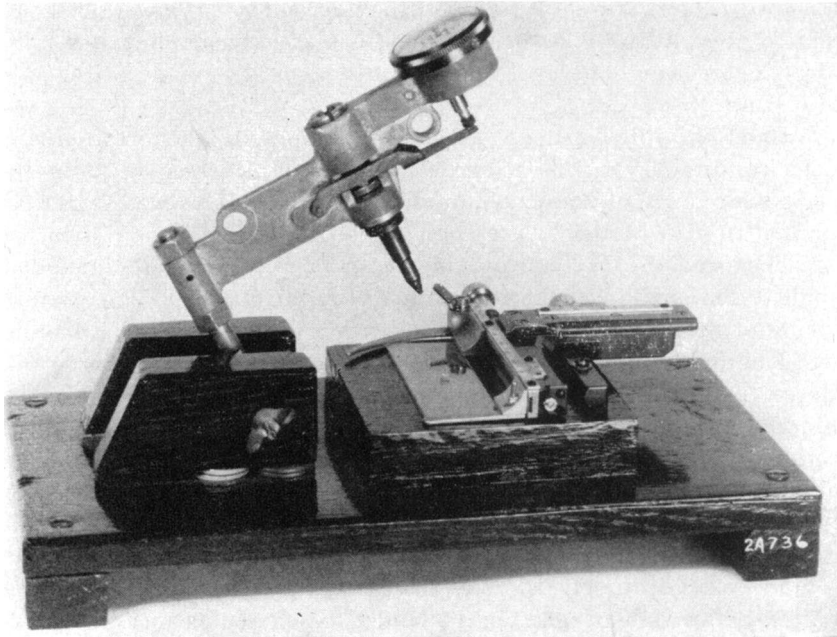

Fig. 1. The converted Barcol Impressor.

is shown in Fig. 1, and a sectional line drawing is shown in Fig. 2.

In Model I of the hardness tester, used to explore the point-to-point variation of a single kernel, a stylus having a conical tip with  $25^\circ$  included angle and terminated in a spherical surface of radius 0.0048 in.

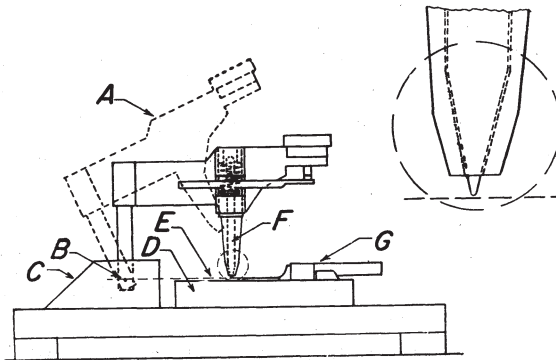

Fig. 2. Diagram of the converted Barcol Impressor. A, tester in lifted position; B, axis about which the tester swings; C, oak supports; D, oak platform which supports the sections to be tested; E, plane which contains the upper surface of the sections and the axis mentioned in B; F, penetrator; G, two-way movement stage.

was used. The maximum reading of the micrometer scale was set at 50. The applied force necessary to achieve a maximum reading was 2 lb. Measurements on hard wheat kernel sections could be made at intervals of 0.4 mm.

Model II of the hardness tester was developed in an effort to obtain a device suitable for comparing the hardness of all wheat varieties under a wide range of ambient humidity conditions. This was of similar construction to Model I except for the stylus and spring. A stylus of hardened steel drill rod was provided with a conical tip of  $13^\circ$  included angle, terminated in a spherical surface of radius 0.011 in. The original spring of the Impressor was replaced with a music wire spring having free length 1.25 in., wire diameter  $1/32$  in., outer diameter  $21/64$  in., eleven free coils, and plain ground ends. It was necessary to use different compressions of the spring for different wheats, because soft wheat varieties crumbled under test conditions suitable for hard wheats. The dial was adjusted to read 100 for maximum deflection of the stylus. A force of 2.2 lb. was necessary to achieve maximum deflection at the soft wheat compression and 3.6 lb. at the hard wheat compression. The compression adjustment is easily made by turning a slotted nut at the top of the instrument (see Fig. 1). Under these circumstances the hardness of a pure lead block was read as 93.5 on the soft wheat scale and 81.5 on the hard wheat scale.

### Procedure

Sections of wheat kernels were prepared with a freezing microtome, following the technique of Grosh and Milner (1). Kernels were placed on the microtome stage and embedded in warm aqueous gelatin solution. Freezing was quickly accomplished with intermittent blasts of carbon dioxide. The kernel was pared down to the desired position and removed from the stage by thawing the gelatin with a soldering iron applied to the stage itself. The kernel slab was then inverted on the stage and refrozen. The sections were then cut to a thickness of 0.8 mm. by cutting the grain to the thickness of a piece of balsa wood frozen to the stage. For good hardness readings, the kernel section must have parallel faces. Transverse kernel sections were used to avoid difficulty with the crease of the kernel in subsequent hardness measurements.

Immediately after the kernel section was prepared, it was cemented to a glass microscope slide with Duco cement. After the cement had dried the kernel was exposed to appropriate experimental conditions (for example, in a humidity chamber) and its hardness tested.

In testing, the microscope slide was mounted on the microscope stage of the hardness tester. Readings from the microscope stage al-

lowed the position of the measurement to be plotted on an enlarged diagram of the kernel to within  $\pm 0.05$  mm. The actual hardness measurement was made by pressing down on the framework of the Impressor with the hand until the flat part of the Impressor spindle was in contact with the specimen. The dial reading reached a maximum value and remained there as long as the force was applied. This reading was recorded as the hardness number of a particular point on the wheat kernel. The results were not altered by variations in hand pressure. About 50 kernels could be sectioned and measured at about six different points on each section in the course of a working day.

### Testing Accuracy of the Modified Instrument

To test the accuracy and reproducibility of the readings of the modified Barcol Impressor, a series of blocks of lead alloys was prepared. The lead blocks were made with antimony content ranging from 0 to

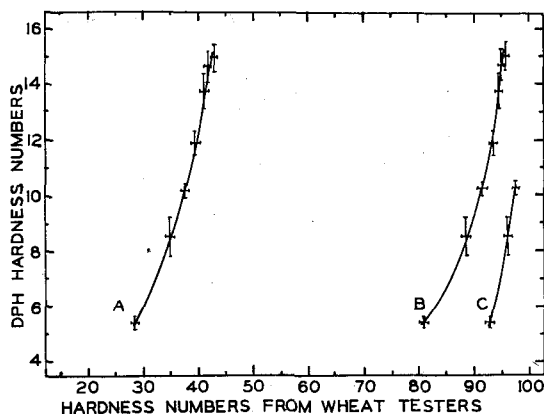

Fig. 3. Diamond Pyramid Hardness, as found with a Vickers hardness tester on samples of lead-antimony alloy, vs. hardness values from the two models of wheat testers found on the same samples. The samples ranged from 0 to 6% antimony. Curve A concerns the soft wheat range of model II; curve B concerns the hard wheat range of model II; curve C concerns the soft wheat range of model II.

6%, in steps of 1%. A series of nine hardness measurements on each block was made with the two models of this tester, and with the Vickers tester. The results are shown in Fig. 3, where each point is plotted as a cross giving the mean hardness and the standard deviation of each block. From the diagram it is apparent that the consistency of the wheat hardness testers is within  $\frac{1}{2}$  hardness number for a single specimen. Some variations may be due to nonuniformity of the specimen, as may be inferred from the range of DPH numbers for each point.

Measurements of the hardness of wheat resulting in greater variation than  $\frac{1}{2}$  hardness number must be attributed to hardness differences in the wheat kernel itself.

To relate the two scales of Model II of the wheat hardness tester, a series of measurements of durum (Mindum) wheat kernels was made. Durum wheat kernels had shown the greatest uniformity of all wheat tested. Groups of 16 durum wheat sections were exposed to varying conditions of humidity. After the sections had come to equilibrium, one measurement was made on each cheek of each section with the soft wheat range, and one measurement on each cheek with the hard wheat

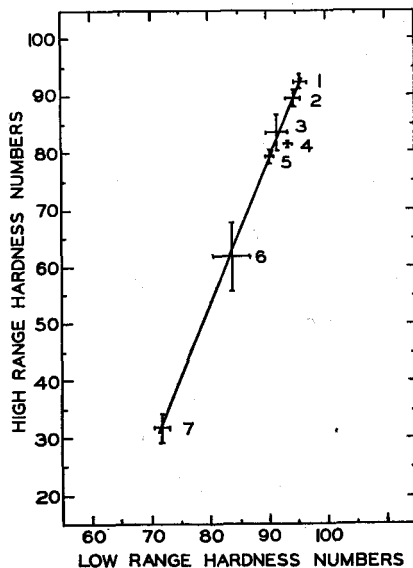

Fig. 4. Graph relating hardness values from the hard wheat (high) range of model II to values from the soft wheat (low) range. The samples used are: 1, durum sections exposed until an equilibrium condition was reached at 33% relative humidity (r.h.); 2, durum sections from wheat at 75% r.h.; 3, durum sections from wheat at 81% r.h.; 4, pure lead; 5, indium solder; 6, durum sections from a 93% r.h.; 7, polyethylene.

range. The 32 hardness values thus obtained for each humidity were then averaged. The results of these measurements are shown in Fig. 4. Measurements with the two ranges were also made on blocks of pure lead, indium solder, and polyethylene. Points obtained from these measurements are also indicated in Fig. 4.

### Results

Figure 5 illustrates the data which can be obtained with Model I of this hardness tester. The hardness of three different sections taken from

three different kernels of hard red winter wheat (Ponca) is shown. These sections were taken from the germ end, the center section, and the brush end of their respective kernels. The size of the impression

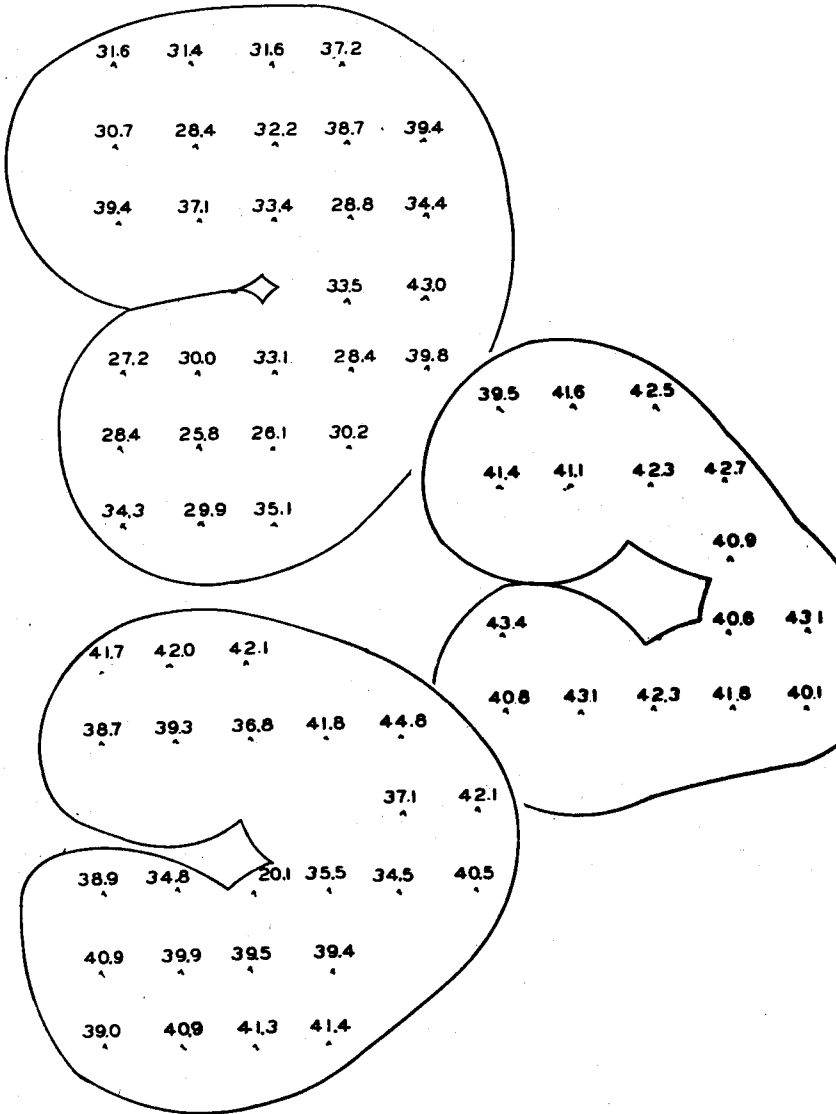

Fig. 5. Hardness values across sections of Ponca wheat, made with model I of the hardness tester. Top, section from germ end; bottom, middle of kernel; right, brush end.



made by the stylus is about the smallest circle which can be drawn around the hardness number.

While these data cannot be considered as representative of the particular variety, several interesting observations can be made. In each of the three sections the periphery of the kernel appears harder than the region around the crease. Thus the average hardness of the center section of Ponca wheat was  $39.7 \pm 2.5$  while the ring of readings closer to the crease averaged  $34.9 \pm 0.4$ , and the ring of values closest to the bran averaged  $41.6 \pm 1.7$ . Similar results were obtained with sections of durum (Mindum) wheat. A brush section of durum wheat had an average hardness of  $38.9 \pm 2.2$  while the hardness of its inner ring was  $36.8 \pm 2.1$ , and the average hardness of its outer ring was  $40.0 \pm 2.0$ . The numbers following the  $\pm$  sign are standard deviations. The hardness of these hard winter and durum sections was comparable, though the durum sections were more nearly uniform. A variation of 10 hardness numbers across one Ponca section was not uncommon, while the hardness of a Mindum section seldom varied more than 4 or 5 hardness numbers.

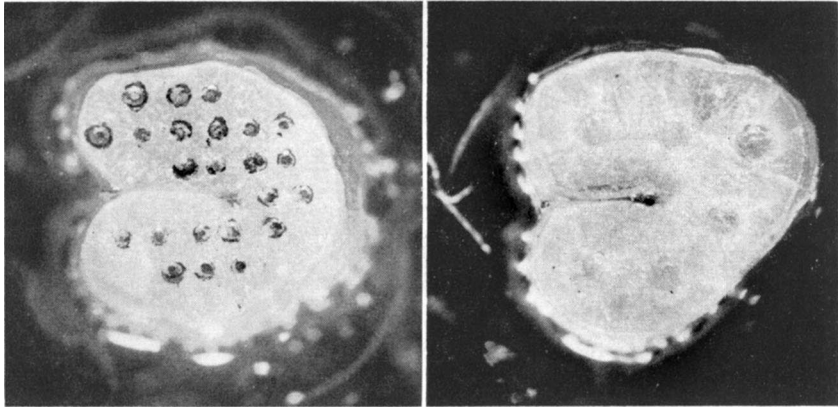

Fig. 6. Left, durum after testing with model I. So that the indentations could be more evident, the penetrator was dabbed with ink before each test. Right, photo of durum after testing with model II.

The photographs of kernel sections after hardness testing with the two models of tester in Fig. 6 show that there is no interference between adjacent hardness measurements.

A number of points will bear further investigation. Among these are the manner of specimen preparation, that is: the influence of freezing, thawing, and cementing on hardness measurements; the influence of ambient humidity and of varietal and agronomic conditions

on wheat hardness. The present paper describes an apparatus which has been developed for wheat hardness measurement and a few specimen results illustrating its use.

#### Literature Cited

1. GROSH, G. M., and MILNER, M. Water penetration and internal cracking in tempered wheat grains. *Cereal Chem.* **36**: 260-273 (1959).
2. KRAMER, H. H., and ALBRECHT, H. R. The adaptation to small samples of the pearling test for kernel hardness in wheat. *J. Am. Soc. Agron.* **40**: 422-431 (1948).
3. PAUKNER, E. Objective measurement of softness for determination of degree of malt solubility. *Brauwissenschaft* **11**: 187-190 (1951).
4. SMEETS, H. S., and CLEVE, H. Determination of conditioning by measuring softness. *Milling Production* **21** (4): 5, 12, 13, 16 (April 1956).

