

1-1-2001

## Test 1796: Case IH STX 275/New Holland TJ 275 Diesel

Follow this and additional works at: <http://digitalcommons.unl.edu/tractormuseumlit>



Part of the [Applied Mechanics Commons](#)

---

"Test 1796: Case IH STX 275/New Holland TJ 275 Diesel" (2001). *Nebraska Tractor Tests*. Paper 268.  
<http://digitalcommons.unl.edu/tractormuseumlit/268>

This Article is brought to you for free and open access by the Tractor Test and Power Museum, The Lester F. Larsen at DigitalCommons@University of Nebraska - Lincoln. It has been accepted for inclusion in Nebraska Tractor Tests by an authorized administrator of DigitalCommons@University of Nebraska - Lincoln.

# NEBRASKA OECD TRACTOR TEST 1796 - SUMMARY 361

## CASE IH STX 275 DIESEL

## ALSO NEW HOLLAND TJ 275 DIESEL

## 16 SPEED

### POWER TAKE-OFF PERFORMANCE

Power HP (kW)	Crank shaft speed rpm	Gal/hr (l/h)	lb/hp.hr (kg/kW.h)	Hp.hr/gal (kW.h/l)	Mean Atmospheric Conditions
---------------------	--------------------------------	-----------------	-----------------------	-----------------------	--------------------------------

### MAXIMUM POWER AND FUEL CONSUMPTION

Rated Engine Speed (PTO speed 1001 rpm)					
238.92 (178.16)	2000	13.61 (51.51)	0.401 (0.244)	17.56 (3.46)	
Maximum Power (2 Hours)					
274.11 (204.40)	1800	15.02 (56.85)	0.386 (0.235)	18.25 (3.60)	

### VARYING POWER AND FUEL CONSUMPTION

238.92 (178.16)	2000	13.61 (51.51)	0.401 (0.244)	17.56 (3.46)	Air temperature
206.68 (154.12)	2036	12.05 (45.61)	0.411 (0.250)	17.15 (3.38)	76°F (24°C)
157.00 (117.07)	2062	9.84 (37.23)	0.441 (0.268)	15.96 (3.14)	Relative humidity
105.75 (78.86)	2087	7.37 (27.90)	0.491 (0.299)	14.36 (2.83)	48%
53.83 (40.14)	2112	5.24 (19.82)	0.685 (0.417)	10.28 (2.03)	Barometer
0.92 (0.68)	2134	3.24 (12.25)	24.916 (15.156)	0.28 (0.06)	28.89" Hg (97.83 kPa)

Maximum Torque - 953 lb.-ft. (1293 Nm) at 1101 rpm

Maximum Torque Rise - 52.0%

Torque rise at 1601 engine rpm - 39%

### DRAWBAR PERFORMANCE

#### FUEL CONSUMPTION CHARACTERISTICS

Power Hp (kW)	Drawbar pull lbs (kN)	Speed mph (km/h)	Crank- shaft speed rpm	Slip %	Fuel Consumption lb/hp.hr (kg/kW.h)	Fuel Consumption Hp.hr/gal (kW.h/l)	Temp. °F (°C) cool- ing med	Air dry bulb	Barom. inch Hg (kPa)
Maximum Power 4th Gear									
211.57 (157.76)	18642 (82.92)	4.26 (6.85)	2002	1.76	0.457 (0.278)	15.43 (3.04)	184 (84)	58 (14)	28.85 (97.70)
75% of Pull at Maximum Power 4th Gear									
163.32 (121.79)	14044 (62.47)	4.36 (7.02)	2043	1.40	0.495 (0.301)	14.24 (2.80)	180 (82)	64 (18)	28.90 (97.87)
50% of Pull at Maximum Power 4th Gear									
111.01 (82.78)	9368 (41.67)	4.44 (7.15)	2073	1.03	0.569 (0.346)	12.39 (2.44)	177 (81)	67 (19)	28.90 (97.87)
75% of Pull at Reduced Engine Speed 7th Gear									
163.22 (121.71)	14052 (62.50)	4.36 (7.01)	1475	1.40	0.442 (0.269)	15.92 (3.14)	182 (83)	65 (18)	28.90 (97.87)
50% of Pull at Reduced Engine Speed 7th Gear									
110.94 (82.73)	9352 (41.60)	4.45 (7.16)	1502	1.03	0.493 (0.300)	14.28 (2.81)	177 (81)	68 (20)	28.90 (97.87)

**Location of Test:** Nebraska Tractor Test Laboratory, University of Nebraska, Lincoln Nebraska 68583-0832

**Dates of Test:** October 3 - 12, 2001

**Manufacturer:** Case Corporation, 700 State Street Racine, Wi. 53404 USA.

**FUEL, OIL and TIME:** Fuel No. 2 Diesel Specific gravity converted to 60°/60° F (15°/15°C) 0.8462 Fuel weight 7.046 lbs/gal (0.844 kg/l) Oil SAE 15W40 API service classification CH-4 Transmission and hydraulic lubricant Case Hy-Tran Ultra fluid Front and rear axle lubricant Case Hy-Tran Ultra fluid Total time engine was operated 16.5 hours

**ENGINE:** Make Case Diesel Type six cylinder vertical with turbocharger and air to air aftercooler Serial No. 46062581 Crankshaft lengthwise Rated engine speed 2000 Bore and stroke 4.488" x 5.315" (114.0 mm x 135.0 mm) Compression ratio 17.1 to 1 Displacement 505 cu in (8268 ml) Starting system 12 volt Lubrication pressure Air cleaner two paper elements and aspirator Oil filter one full flow cartridge Oil cooler engine coolant heat exchanger for crankcase oil, radiator for transmission and hydraulic oil Fuel filter one paper element Fuel cooler radiator for returned fuel Muffler vertical Cooling medium temperature control one thermostat and variable speed fan

**ENGINE OPERATING PARAMETERS:** Fuel rate: 91.7 - 97.2 lb/h (41.6 - 44.1 kg/h) High idle: 2125 - 2165 rpm Turbo boost: nominal 22.2 - 25.1 psi (153 - 173 kPa) as measured 23.2 psi (160 kPa)

**CHASSIS:** Type four wheel drive with duals Serial No. \*JEE0098550\* Tread width rear 61.0" (1549 mm) to 130.0" (3302 mm) front 61.0" (1549 mm) to 130.0" (3302 mm) Wheelbase 139.0" (3531 mm) Hydraulic control system direct engine drive Transmission selective gear fixed ratio with full range operator controlled powershift Nominal travel speeds mph (km/h) first 2.44 (3.93) second 2.94 (4.73) third 3.55 (5.71) fourth 4.28 (6.88) fifth 4.91 (7.90) sixth 5.39 (8.68) seventh 5.92 (9.52) eighth 6.50 (10.46) ninth 7.14 (11.49) tenth 7.85 (12.63) eleventh 8.60 (13.84) twelfth 9.45 (15.21) thirteenth 10.84 (17.46) fourteenth 13.06 (21.03) fifteenth 15.79 (25.41) sixteenth 19.01 (30.59) reverse 3.70 (5.95), 8.17 (13.15) Clutch multiple wet disc electro-hydraulically operated by foot pedal Brakes single wet disc hydraulically actuated by foot pedal Steering hydrostatic and articulated Power take-off 1000 rpm at 1998 engine rpm Unladen tractor mass 31785 lb (14417 kg)

**DRAWBAR PERFORMANCE**  
**MAXIMUM POWER IN SELECTED GEARS**

Power Hp (kW)	Drawbar pull lbs (kN)	Speed mph (km/h)	Crank- shaft speed rpm	Slip %	Fuel Consumption lb/lp.hr (kg/kW.h)	Consumption Hp.hr/gal (kW.h/l)	Temp. <sup>o</sup> F(°C) cool- ing med	Air dry bulb	Barom. inch Hg (kPa)
1st Gear									
204.45 (152.46)	32944 (146.54)	2.33 (3.75)	2021	6.88	0.467 (0.284)	15.08 (2.97)	179 (82)	56 (13)	28.82 (97.60)
2nd Gear									
231.79 (172.85)	32434 (144.27)	2.68 (4.31)	1912	5.69	0.460 (0.280)	15.33 (3.02)	182 (83)	56 (13)	28.83 (97.63)
3rd Gear									
246.13 (183.54)	29681 (132.03)	3.11 (5.00)	1798	3.72	0.438 (0.267)	16.08 (3.17)	186 (85)	57 (14)	28.84 (97.66)
4th Gear									
246.51 (183.82)	24230 (107.78)	3.82 (6.14)	1806	2.49	0.439 (0.267)	16.06 (3.16)	189 (87)	58 (14)	28.85 (97.70)
5th Gear									
245.06 (182.74)	20968 (93.27)	4.38 (7.05)	1800	2.04	0.439 (0.267)	16.05 (3.16)	190 (88)	59 (15)	28.86 (97.73)
6th Gear									
245.90 (183.36)	19104 (84.98)	4.83 (7.77)	1801	1.95	0.437 (0.266)	16.11 (3.17)	189 (87)	59 (15)	28.86 (97.73)
7th Gear									
241.39 (180.01)	17094 (76.04)	5.30 (8.52)	1799	1.76	0.447 (0.272)	15.76 (3.10)	190 (88)	60 (16)	28.87 (97.77)
8th Gear									
242.47 (180.81)	15567 (69.24)	5.84 (9.40)	1802	1.58	0.444 (0.270)	15.87 (3.13)	190 (88)	60 (16)	28.87 (97.77)
9th Gear									
239.59 (178.66)	14040 (62.45)	6.40 (10.30)	1795	1.40	0.447 (0.272)	15.76 (3.10)	190 (88)	61 (16)	28.86 (97.73)
10th Gear									
239.92 (178.91)	12727 (56.61)	7.07 (11.38)	1803	1.31	0.447 (0.272)	15.78 (3.11)	191 (88)	62 (17)	28.87 (97.77)
11th Gear									
232.40 (173.30)	11231 (49.96)	7.76 (12.49)	1803	1.21	0.465 (0.283)	15.14 (2.98)	191 (88)	62 (17)	28.88 (97.80)
12th Gear									
234.88 (175.15)	10340 (45.99)	8.52 (13.71)	1800	1.03	0.454 (0.276)	15.52 (3.06)	191 (88)	63 (17)	28.89 (97.83)

**REPAIRS AND ADJUSTMENTS:** No repairs or adjustments.

**REMARKS:** All test results were determined from observed data obtained in accordance with official OECD, SAE and Nebraska test procedures. The drawbar pull in 1st gear was limited to avoid excessive tractor bouncing. For the maximum power tests, the fuel temperature at the injection pump inlet was maintained at 112°F (44°C). The performance figures on this Summary were taken from a test conducted under the OECD Code II test procedure.

**Supplemental report:** New Holland TJ 275 Diesel. Manufactured for New Holland by Case Corporation.

We, the undersigned, certify that this is a true and correct report of official Tractor Test No. **1796**, Nebraska Summary 361, October 26, 2001.

Leonard L. Bashford  
Director

M.F. Kocher  
V.I. Adamchuk  
G.J. Hoffman  
Board of Tractor Test Engineers

**TRACTOR SOUND LEVEL WITH CAB**

**dB(A)**

At no load in 5th gear	72.4
Bystander in 16th gear	87.6

**TIRES AND WEIGHT**

**Rear tires** - No., size, ply & psi (kPa)  
**Front tires** - No., size, ply & psi (kPa)  
**Height of Drawbar**  
**Static Weight with operator**- Rear  
- Front  
- Total

**Tested Without Ballast**

Four 20.8R42; \*\*; 8(55)  
Four 20.8R42; \*\*; 11(75)  
14.5 in (370 mm)  
14030 lb (6364 kg)  
17930 lb (8133 kg)  
31960 lb (14497 kg)

### THREE POINT HITCH PERFORMANCE (OECD Static Test)

CATEGORY: IV

Quick Attach: yes

Maximum Force Exerted

Through Whole Range: 15678 lbs (69.7 kN)

		High flow option
i) Opening pressure of relief valve:	NA	NA
Sustained pressure of the open relief valve:	2870 psi (198 bar)	2955 psi (204 bar)
ii) Pump delivery rate at minimum pressure and rated engine speed:	40.9 GPM (154.8 l/min)	58.0 GPM (219.6 l/min)
iii) Pump delivery rate at maximum hydraulic power:	34.6 GPM (131.0 l/min)	54.6 GPM (206.7 l/min)
Delivery pressure:	2450 psi (169 bar)	2550 psi (176 bar)
Power:	49.5 HP (36.9 kW)	81.2 Hp (60.6 kW)

### HITCH DIMENSIONS AS TESTED - NO LOAD

	inch	mm
A	33.7	855
B	29.9	760
C	23.2	590
D	22.0	558
E	13.5	342
F	13.4	340
G	37.2	945
H	2.7	68
I	21.2	538
J	23.8	605
K	29.0	736
L	54.8	1391
*L'	62.0	1575
M	27.0	687
N	39.3	997
O	8.0	203
P	47.6	1209
Q	40.2	1020
R	39.5	1004

\*L' to Quick Attach ends

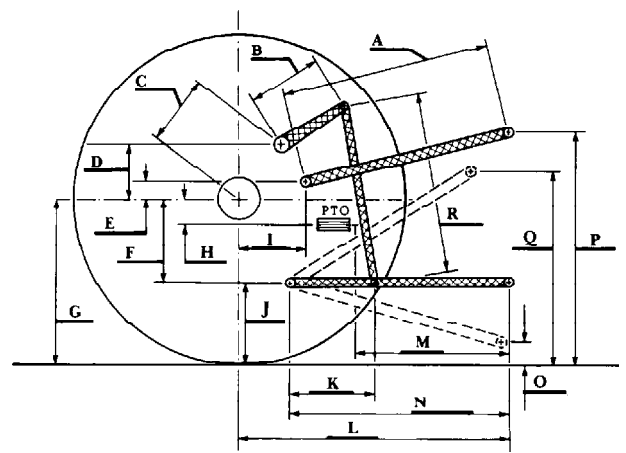

Case IH STX 275 Diesel

Agricultural Research Division  
 Institute of Agriculture and Natural Resources  
 University of Nebraska Lincoln  
 Darrell Nelson, Dean and Director