

Tractor Test and Power Museum, The Lester F. Larsen

UNL Larsen Tractor Museum Archives

University of Nebraska - Lincoln

Year 2007

Test 1915: New Holland TG305 and
T8040 Diesel 19-speed

Tractor Museum
University of Nebraska-Lincoln, TractorMuseumArchives@unl.edu

NEBRASKA OECD TRACTOR TEST 1915–SUMMARY 587

NEW HOLLAND TG 305 DIESEL

ALSO NEW HOLLAND T8040 DIESEL

19 SPEED

Location of tests: Nebraska Tractor Test Laboratory, University of Nebraska, Lincoln, Nebraska 68583-0832

Dates of tests: October 26 to November 14, 2007

Manufacturer: CNH America LLC, 700 State St. Racine, WI. 53404 USA

FUEL, OIL and TIME: Fuel No. 2 Diesel Specific gravity converted to 60°/60°F (15°/15°C) 0.8417 Fuel weight 7.008 lbs/gal (0.840 kg/l) Oil SAE 15W40 API service classification CI-4 Transmission and hydraulic lubricant New Holland Multi-Tran fluid Front axle lubricant SAE 85W-140 API GL-5 Total time engine was operated: 22.5 hours

ENGINE: Make CNH Engine Corporation Diesel **Type** six cylinder vertical with turbocharger and air to air intercooler **Serial No.** *46733979* **Crankshaft** lengthwise **Rated engine speed** 2200 **Bore and stroke** 4.488" x 5.315" (114.0 mm x 135.0 mm) **Compression ratio** 17.5 to 1 **Displacement** 505 cu in (8268 ml) **Starting system** 12 volt **Lubrication** pressure **Air cleaner** two paper elements and aspirator **Oil filter** one full flow cartridge **Oil cooler** engine coolant heat exchanger for crankcase oil, radiator for hydraulic and transmission oil **Fuel filter** two paper elements **Fuel cooler** radiator for pump return fuel **Muffler** vertical **Cooling medium temperature control** 2 thermostats and variable speed fan

ENGINE OPERATING PARAMETERS: Fuel rate: 113.2-124.8 lb/h (51.4 - 56.6 kg/h) **High idle:** 2380-2420 rpm **Turbo boost:** nominal 21.0 - 25.4 psi (145 - 175 kPa) as measured 23.6 psi (162 kPa)

CHASSIS: Type front wheel assist **Serial No.** *Z7RW02908* **Tread width** rear 64.0" (1626 mm) to 129.0" (3277 mm) front 60.0" (1524 mm) to 88.0" (2235 mm) **Wheelbase** 129.3" (3284 mm) **Hydraulic control system** direct engine drive **Transmission** selective gear fixed ratio with full range operator controlled powershift **Nominal travel speeds mph (km/h)** first 1.97 (3.17) second 2.26 (3.64) third 2.60 (4.19) fourth 2.99 (4.81) fifth 3.43 (5.52) sixth 3.93 (6.33) seventh 4.59 (7.38) eighth 5.26 (8.47) ninth 6.06 (9.77) tenth 6.96 (11.20) eleventh 7.98 (12.85) twelfth 9.16 (14.74) thirteenth 11.41 (18.37) fourteenth 13.09 (21.07) fifteenth 15.10 (24.30) sixteenth 17.32 (27.87) seventeenth 19.87 (31.97) eighteenth 22.79 (36.67) nineteenth 24.86 (40.00) (1900 engine rpm) reverse 2.83 (4.56), 3.26 (5.24), 6.61 (10.63), 7.57 (12.19) **Clutch** multiple wet disc electrohydraulically operated by foot pedal **Brakes** wet disc hydraulically operated by two foot pedals that can be locked together **Steering** hydrostatic **Power take-off** 540 rpm at 1988 engine rpm or 1000 rpm at 1984 engine rpm **Unladen tractor mass** 21665 lb (9827 kg)

POWER TAKE-OFF PERFORMANCE

Power HP (kW)	Crank shaft speed rpm	Gal/hr (l/h)	lb/hp.hr (kg/kW.h)	Hp.hr/gal (kW.h/l)	Mean Atmospheric Conditions
MAXIMUM POWER AND FUEL CONSUMPTION					
Rated Engine Speed—(PTO speed—1109 rpm)					
257.22 (191.81)	2200	16.20 (61.32)	0.441 (0.268)	15.88 (3.13)	
Standard Power Take-off Speed (1008 rpm)					
294.37 (219.55)	2000	16.64 (63.00)	0.396 (0.241)	17.69 (3.48)	
Maximum Power (1 hour)					
294.37 (219.55)	2000	16.64 (63.00)	0.396 (0.241)	17.69 (3.48)	
VARYING POWER AND FUEL CONSUMPTION					
257.22 (191.81)	2200	16.20 (61.32)	0.441 (0.268)	15.88 (3.13)	Air temperature
222.83 (166.16)	2244	15.05 (56.99)	0.473 (0.288)	14.80 (2.92)	79°F (26°C)
170.09 (126.84)	2279	12.80 (48.45)	0.527 (0.321)	13.29 (2.62)	Relative humidity
115.61 (86.21)	2331	9.90 (37.49)	0.600 (0.365)	11.67 (2.30)	25%
58.88 (43.91)	2369	6.72 (25.44)	0.800 (0.487)	8.76 (1.73)	Barometer
1.79 (1.34)	2409	3.71 (14.04)	14.502 (8.821)	0.48 (0.10)	28.93" Hg (97.97 kPa)

Maximum torque - 965 lb.-ft. (1309 Nm) at 1502 rpm

Maximum torque rise - 57.2%

Torque rise at 1800 engine rpm - 38%

Power increase at 2000 engine rpm - 14.4%

DRAWBAR PERFORMANCE

UNBALLASTED - FRONT DRIVE ENGAGED FUEL CONSUMPTION CHARACTERISTICS

Power Hp (kW)	Drawbar pull lbs (kN)	Speed mph (km/h)	Crank-shaft speed rpm	Slip %	Fuel Consumption lb/hp.hr (kg/kW.h)	Temp. °F (°C) cool-ing med	Barom. inch Hg (kPa)
Maximum Power—9th Gear							
216.81 (161.68)	14056 (62.52)	5.78 (9.31)	2199	3.3	0.520 (0.316)	13.48 (2.66)	191 (88)
75% of Pull at Maximum Power—9th Gear							
169.33 (126.27)	10571 (47.02)	6.01 (9.67)	2261	2.3	0.586 (0.357)	11.95 (2.35)	191 (88)
50% of Pull at Maximum Power—9th Gear							
116.27 (86.70)	7054 (31.38)	6.18 (9.95)	2306	1.4	0.705 (0.429)	9.95 (1.96)	191 (88)
75% of Pull at Reduced Engine Speed—11th Gear							
170.34 (127.02)	10580 (47.06)	6.04 (9.72)	1729	2.2	0.507 (0.308)	13.82 (2.72)	190 (88)
50% of Pull at Reduced Engine Speed—11th Gear							
116.31 (86.73)	7053 (31.37)	6.18 (9.95)	1753	1.4	0.553 (0.336)	12.67 (2.50)	187 (86)

DRAWBAR PERFORMANCE
UNBALLASTED - FRONT DRIVE ENGAGED
MAXIMUM POWER IN SELECTED GEARS

Power Hp (kW)	Drawbar pull lbs (kN)	Speed mph (km/h)	Crank- shaft speed rpm	Slip %	Fuel Consumption lb/hp.hr (kg/kW.h)	Fuel Consumption Hp.hr/gal (kW.h/l)	Temp. °F (°C) cool- ing med	Air dry bulb	Barom. inch Hg (kPa)
6th Gear									
191.10 (142.50)	20898 (92.96)	3.43 (5.52)	2219	12.6	0.600 (0.365)	11.69 (2.30)	192 (89)	65 (18)	28.84 (97.66)
7th Gear									
215.25 (160.51)	19846 (88.28)	4.07 (6.55)	2141	8.2	0.526 (0.320)	13.33 (2.63)	192 (89)	65 (18)	28.81 (97.56)
8th Gear									
232.03 (173.02)	19317 (85.92)	4.50 (7.25)	2051	6.9	0.498 (0.303)	14.07 (2.77)	191 (88)	66 (19)	28.80 (97.53)
9th Gear									
247.56 (184.61)	18065 (80.35)	5.14 (8.27)	1997	5.3	0.470 (0.286)	14.90 (2.94)	191 (88)	66 (19)	28.79 (97.49)
10th Gear									
249.23 (185.85)	15598 (69.38)	5.99 (9.64)	1999	4.0	0.466 (0.283)	15.04 (2.96)	192 (89)	69 (21)	29.08 (98.48)
11th Gear									
249.19 (185.82)	13498 (60.04)	6.92 (11.14)	1998	3.0	0.466 (0.284)	15.02 (2.96)	191 (88)	69 (21)	29.07 (98.44)
12th Gear									
247.41 (184.49)	11589 (51.55)	8.01 (12.88)	2002	2.5	0.468 (0.285)	14.97 (2.95)	192 (89)	69 (21)	29.08 (98.48)

REPAIRS AND ADJUSTMENTS: No repairs or adjustments.

REMARKS: All test results were determined from observed data obtained in accordance with official OECD, SAE and Nebraska test procedures. For the maximum power tests the fuel temperature at the primary fuel filter was maintained at 104°F (40°C). The performance results on this summary were taken from OECD tests conducted under the Code II Test Code Procedure.

We, the undersigned, certify that this is a true and correct report of official Tractor Test No. **1915**, Nebraska Summary 587, December 17, 2007.

Roger M. Hoy
 Director

M.F. Kocher
 V.I. Adamchuk
 J.A. Smith
 Board of Tractor Test Engineers

TRACTOR SOUND LEVEL WITH CAB

dB(A)

At no load in 7th gear	72.0
Bystander in 18th gear	88.4

TIRES, BALLAST AND WEIGHT

	With Ballast	Without Ballast
Rear Tires -No., size, ply & psi (kPa)	Four 520/85R42;**,13(90)	Two 520/85R42;**,17(115)
Ballast - Duals (total)	1950 lb (885 kg)	None
- Cast Iron (total)	4910 lb (2227 kg)	None
Front Tires -No., size, ply & psi (kPa)	Four 420/90R30;**,12(85)	Two 420/90R30;**,15(105)
Ballast - Duals (total)	1030 lb (467 kg)	None
- Cast Iron (total)	3520 lb (1597 kg)	None
Height of Drawbar	17.5 in (445 mm)	17.0 in (430 mm)
Static Weight with operator - Rear	20150 lb (9140 kg)	13995 lb (6348 kg)
- Front	13100 lb (5942 kg)	7845 lb (3558 kg)
- Total	33250 lb (15082 kg)	21840 lb (9906 kg)

DRAWBAR PERFORMANCE
BALLASTED - 2000 ENGINE RPM
MAXIMUM POWER IN SELECTED GEARS

Power Hp (kW)	Drawbar pull lbs (kN)	Speed mph (km/h)	Crank- shaft speed rpm	Slip %	Fuel Consumption lb/hp.hr (kg/kW.h)	Fuel Consumption Hp.hr/gal (kW.h/l)	Temp. °F (°C) cool- ing med	Air dry bulb	Barom. inch Hg (kPa)
3rd Gear									
204.97 (152.85)	33721 (150.00)	2.28 (3.67)	2199	11.0	0.551 (0.335)	12.71 (2.50)	193 (89)	55 (13)	29.11 (98.58)
4th Gear									
224.88 (167.69)	32004 (142.36)	2.63 (4.24)	2130	7.2	0.505 (0.307)	13.86 (2.73)	193 (89)	58 (14)	29.08 (98.48)
5th Gear									
241.60 (180.16)	31154 (138.58)	2.91 (4.68)	2027	6.4	0.479 (0.291)	14.64 (2.88)	192 (89)	59 (15)	29.08 (98.48)
6th Gear									
249.32 (185.92)	27882 (124.02)	3.35 (5.40)	2000	4.4	0.465 (0.283)	15.07 (2.97)	192 (89)	59 (15)	29.08 (98.48)
7th Gear									
254.44 (189.74)	24088 (107.15)	3.96 (6.37)	1999	3.6	0.456 (0.278)	15.36 (3.03)	192 (89)	59 (15)	29.07 (98.44)
8th Gear									
254.08 (189.47)	20847 (92.73)	4.57 (7.36)	1999	2.7	0.458 (0.278)	15.31 (3.02)	192 (89)	60 (16)	29.06 (98.41)
9th Gear									
252.19 (188.06)	17841 (79.36)	5.30 (8.53)	2002	2.3	0.462 (0.281)	15.18 (2.99)	192 (89)	61 (16)	29.04 (98.34)
10th Gear									
251.53 (187.56)	15462 (68.78)	6.10 (9.82)	1999	2.0	0.462 (0.281)	15.16 (2.99)	192 (89)	61 (16)	29.03 (98.31)
11th Gear									
248.10 (185.01)	13280 (59.07)	7.01 (11.28)	1999	1.7	0.468 (0.285)	14.97 (2.95)	192 (89)	61 (16)	29.02 (98.27)
12th Gear									
243.67 (181.70)	11310 (50.31)	8.08 (13.00)	2001	1.4	0.476 (0.290)	14.72 (2.90)	192 (89)	61 (16)	29.01 (98.24)

THREE POINT HITCH PERFORMANCE(OECD Static Test)

CATEGORY: III

Quick Attach: Yes

Maximum force exerted through whole range:	16375 lb (72.8 kN)	High Lift Option 17931 lb (79.8 kN)
		Megaflow pump 2949 psi (203 bar)
i) Sustained pressure at compensator cutoff:	3169 psi (219 bar)	
ii) Pump delivery rate at minimum pressure and rated engine speed:	44.0 GPM (166.6 l/min)	31.4 GPM (118.9 l/min)
Combined flow:	75.4 GPM (285.4 l/min)	
iii) Pump delivery rate at maximum hydraulic power:	41.8 GPM (158.2 l/min)	31.9 GPM (120.8 l/min)
Delivery pressure:	2948 psi (203 bar)	2705 psi (186 bar)
Power:	71.9 HP (53.6 kW)	50.3 Hp (37.5 kW)

HITCH DIMENSIONS AS TESTED—NO LOAD

	inch	mm
A	28.2	718
B	20.5	520
C	22.9	581
D	20.7	525
E	10.5	266
F	15.7	400
G	36.4	925
H	3.5	90
I	20.9	530
J	20.7	525
K	30.2	768
L	46.1	1170
*L'	50.7	1287
M	20.1	511
N	38.2	970
O	9.0	230
P	47.6	1210
Q	40.7	1035
R	39.2	995

*L' to Quick Attach ends

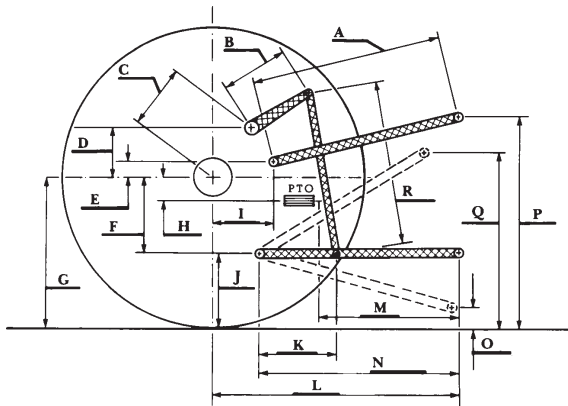

NEW HOLLAND TG305 DIESEL