

8-1932

## EC1441 Revised 1932 Practical Poultry Equipment

J. H. Claybaugh

Follow this and additional works at: <http://digitalcommons.unl.edu/extensionhist>

---

Claybaugh, J. H., "EC1441 Revised 1932 Practical Poultry Equipment" (1932). *Historical Materials from University of Nebraska-Lincoln Extension*. 2565.

<http://digitalcommons.unl.edu/extensionhist/2565>

This Article is brought to you for free and open access by the Extension at DigitalCommons@University of Nebraska - Lincoln. It has been accepted for inclusion in Historical Materials from University of Nebraska-Lincoln Extension by an authorized administrator of DigitalCommons@University of Nebraska - Lincoln.

S  
85  
E7  
#1441  
c.1

# Practical Poultry Equipment

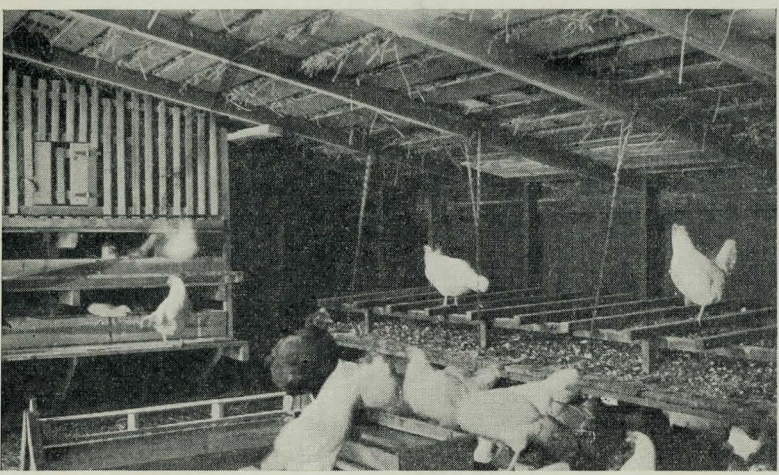

The University of Nebraska Agricultural College Extension Service  
and United States Department of Agriculture Cooperating  
W. H. Brokaw, Director, Lincoln

(105) - 1471.3.3

Distributed in furtherance of cooperative agricultural extension work. Acts of May 8, 1914, and June 30, 1914. Extension Service of The University of Nebraska Agricultural College and U. S. Department of Agriculture cooperating. W. H. Brokaw, Director of Agricultural Extension Service.

(12-26-10M)

(9-28-15M)

(8-32-10M)

## Practical Poultry Equipment

BY J. H. CLAYBAUGH

Poultry raisers of Nebraska are now expecting to get eggs during all months of the year. The production records of those cooperating with the extension service in the record flock project have shown that profitable fall and winter egg production is possible if certain principles of management are followed. The development of many commercial poultry flocks with high production records has demonstrated that hens can be expected to lay during the winter. These same factors have served to demonstrate to poultry producers that they must have well grown and well developed pullets ready to lay during the fall months if they are to expect winter eggs. This calls for full feeding of balanced mashes to the growing stock during the summer. Many requests have been received for simple mash feeding equipment that can be made at home.

The problem of reducing the number of under-sized, disease-carrying runts among their poultry is receiving the careful consideration of all thoughtful poultry keepers. The attention which these runts are receiving is due to a number of factors. The poultry population of Nebraska is becoming more and more dense. This increase in density naturally develops new problems of controlling filth borne diseases and parasites. The Department of Animal Pathology and Hygiene has partially surveyed the poultry disease problem in the state. This work acquainted many poultry keepers with the causes of their troubles. Dealers in poultry have begun to buy on a graded basis and are refusing to buy emaciated runts or birds showing signs of a very low vitality. Thus the poultry raisers are constantly observing the evil effects as well as the causes of these undesirables, and thus increased attention has been given to methods of eliminating these evils. As these poultry raisers realize that clean ground and clean feeding methods aid in the prevention of the filth borne diseases and parasites, the poultry department has had repeated requests for methods of making equipment that will keep feed and water clean.

### THE REEL-PROTECTED FEED TROUGH

The reel-protected and "V" shaped feed trough similar to the one illustrated is popular with Nebraska poultrymen. Different sizes of the same type can be made for baby



chicks, growing chicks, and laying hens. Either mash, shredded green feed, or grain can be fed in these feeders.

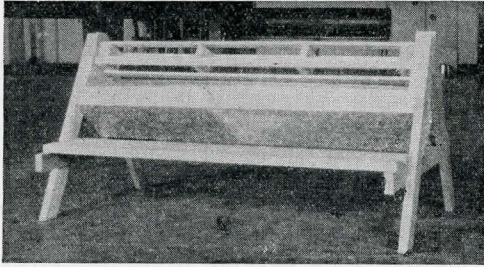

FIG. 1.—The "V" shaped feed trough made of various sizes of either metal or crating lumber  $\frac{3}{8}$  inch thick.

At least three such feed troughs are recommended per 100 hens.

The qualifications for feed troughs for hens are that they be well lighted, easily accessible but elevated, waste proof, light in weight, low in costs, and that the feed be kept clean.

A modification of the "V" shaped feeder is used by turkey growers as an outside feed trough. These are provided with inverted troughs that serve as a cap to keep out rain and aid in preventing mash blowing out. Figure 2 shows how these are constructed.

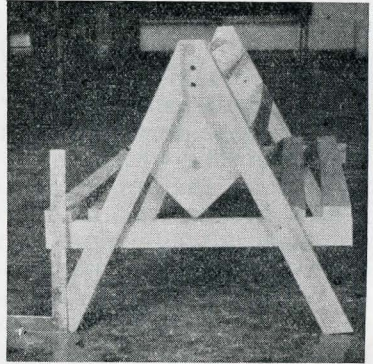
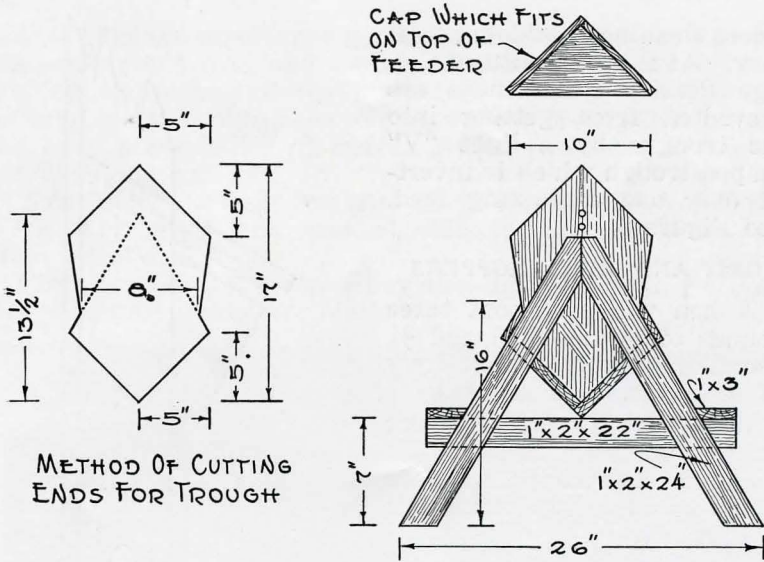

FIG. 2.—End view of the feeder.

#### OTHER FEED TROUGHS

Because they desire to keep all feed as sanitary as possible, careful poultrymen object to feeding sprouted oats on the floor litter. Open troughs protected by a reel or an inverted trough have come into high favor as a cleaner way of feeding germinated oats, moist mash, smaller quantities of dry mash, and at times even the scratch feed. See Figure 4. Some people make flat-bottomed troughs six inches wide and four inches deep protected by a reel or a board flopper. Others prefer a "V" shaped trough made by nailing two six inch boards together. The "V" shaped trough is said to be more easily cleaned where troughs are used on the floor rather than being elevated on benches



OUT-DOOR FEED TROUGH FOR TURKEYS

FIG. 3.—End view of cap covered outdoor feed trough for turkeys.

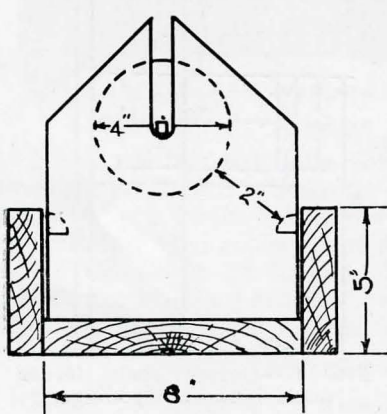

FIG. 4.—End view of large trough where a 4" brooder stove pipe or a gutter pipe is used for a reel. A lip for the edge of the trough is made by nailing quarter round to the inside of trough.

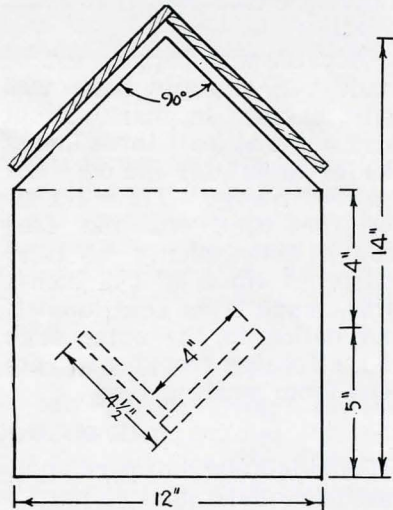

FIG. 5.—A wet mash feed trough protected by the inverted trough.

where cleaning is seldom necessary. At the Agricultural College Poultry Plant, hens are prevented from getting into the troughs by a light "V" shaped trough which is inverted over one containing feed. See Figure 5.

#### GRIT AND SHELL HOPPERS

A hen will eat about three pounds of oyster shell and  $\frac{3}{4}$  pound of grit a year. Relatively small hoppers can be used.

Where the hen house is not boarded up on the inside of the studding, shell hoppers can be made between two studdings in Figure 6.

The bottom board should first be nailed to the boards that are to be the sides and front of the feed trough. The side boards are then nailed to the studding. Cover is held in place by cleats nailed on under sides.

Movable shell hoppers can be made very cheaply from well built boxes. In marking out such a box at least three inches should be left for the depth of the feed trough. Three inches for the width of the feed trough gives plenty of head space. A lip 1 or  $1\frac{1}{2}$  inches wide, made from thin lumber, and nailed to the outer edge of the feeding trough prevents hens from wasting feed.

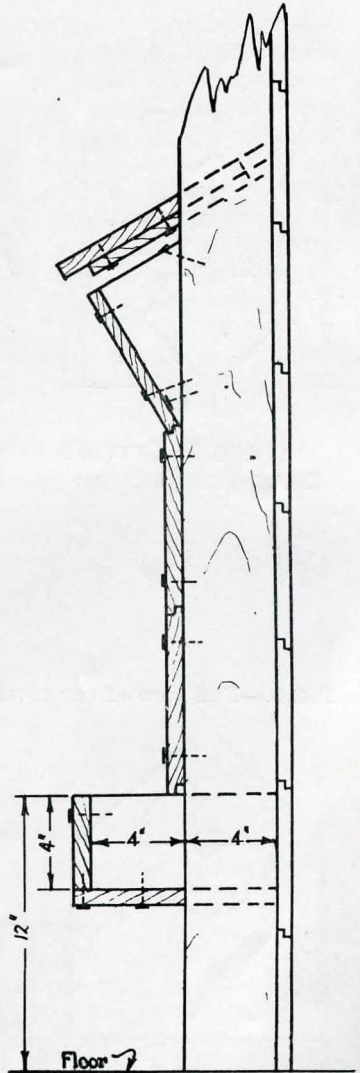

FIG. 6.—Oyster shell feeder made between studdings.

#### THE OUTDOOR FEEDER

Outside feed hoppers should be considered a necessary part of modern poultry yard equipment. They can be used for growing stock on range where both mash and scratch are self-fed. They can be used on farms to encourage the



chicks to range on cleaner ground and away from old stock, disease-laden yards, and sources of danger such as the hog and cattle yards and the highways. Outside feeders can be used to encourage hens to range away from yards where the easy accessibility of coarse grains promotes excessive fat development.

This feeder is built in three parts for ease of handling. It is rain proof and has a wide throat which lessens clogging of feed.

Circular No. 1469 describes the detailed plan of constructing this bungalow feeder.

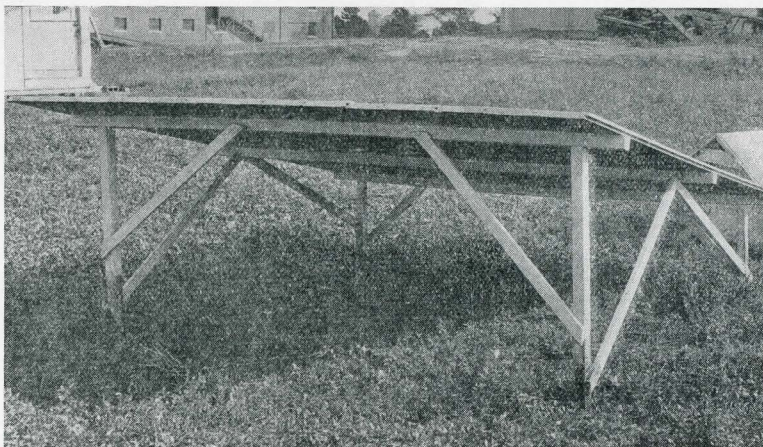

FIG. 7.—This shade shelter is easily moved.

#### SHADE SHELTER

Many poultry yards in Nebraska do not have trees which provide sufficient shade for the chicks. At the Agricultural College Poultry Plant artificial shade has been provided by building shed roofs about 6 feet square, 3 feet high on the north side, and 18 inches high on the south or low side. These are built on frames made of 2x2 inch material. The frame is braced as indicated in Figure 7.

#### WATERING DEVICES

Many of the poultry diseases are spread through an infected water supply. The Department of Animal Pathology and Hygiene has tested out the self-cleaning bubbler as a means of keeping the water supply strictly sanitary. Extension Circular No. 1440 has the following to say about these bubblers: "A more efficient method of supplying a



safe water to poultry can be proposed in the form of a self-cleaning watering cup on the plan of the sanitary bubbler now in common use in public buildings, parks, etc. It can only be put in practice where running water is constantly available, but even the ordinary windmill and tank equipment of many farms could be utilized to advantage in providing this more or less ideal method of watering poultry." The drinking cup is placed about 8 inches above the ground, is kept clean, and can be regarded as strictly sanitary.

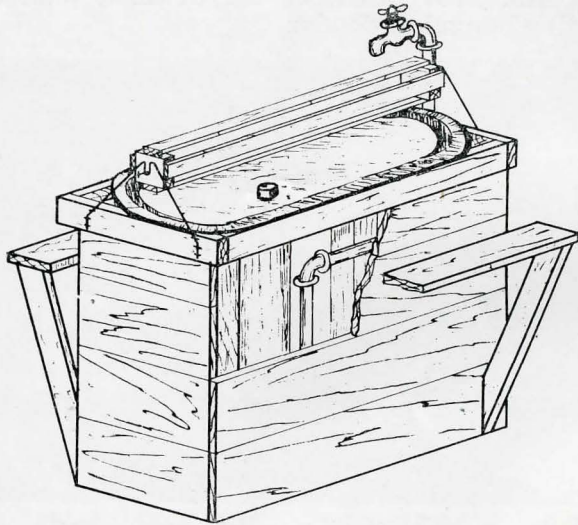

FIG. 8.—A waterer of this kind is in practical use on one Nebraska poultry farm.

A modification of this idea of a bubbling fountain has been installed in some Nebraska poultry farms. An 18-inch metal hog trough holds about 10 quarts of water. This supply will last a few hours after the water is turned off. When covered by a large reel or a wire frame but little filth can get into the trough. This also can be heated during cold weather by using an incubator lamp beneath the trough and enclosing the frame which carries the water trough.

Other poultrymen who have water piped through their chicken houses have installed automatic floats on watering pans along the partitions between rooms. This equipment is similar to automatic hog waterers and is used with lamp heaters during cold weather.

**WATERING STANDS**

Wet spots on the floor, as well as litter and dirt scratched into the water pails and pans, are prevented by the use of watering stands. No floor space is occupied by the watering vessels when they are elevated on such stands. Such a watering stand as here illustrated can be used where buckets

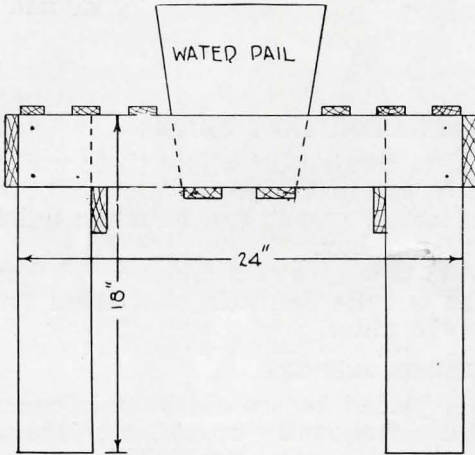

FIG. 9.—A stand for the water bucket.

are used for watering the hens. More water as well as mash is consumed if the water is placed near the dry mash troughs. Two pails, each holding from 10 to 12 quarts, will furnish the volume of water necessary daily for 100 hens in medium lay. Reports indicate that one common managerial fault is the lack of volume and cleanliness of the water supply.

**BILL OF MATERIAL:**

- 4 legs .....1"x4"x18"
- 4 sides .....1"x4"x24"
- 10 cleats .....1"x2"x24"

Such a stand is also useful as a bench where the coop of broody hens may be set outdoors in the shade of a tree.

**WATERING STANDS BUILT LOW**

Some poultrymen think that hens will drink more water when they can reach it while standing on the ground than they will drink when they are forced to hop up onto a stand.

A simple stand which elevates a crock of milk or a refrigerator pan of water but slightly, can be made from two of the end boards of an apple or orange box. Figure 10 indicates one method of making these with a removable top.

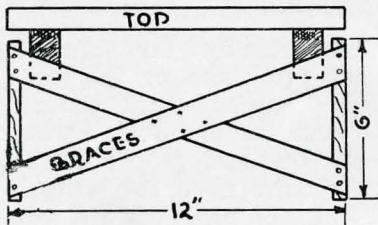

## BILL OF MATERIAL:

1 top .....	11½" x 11½"
2 sides .....	5¾" x 11½"
4 brace strips .....	¼" x 1" x 14"

FIG. 10.—A low stand for a covered milk crock.

#### WATERING STANDS FOR BABY CHICKS

Baby chicks soon begin to scratch litter into their water and milk supply unless these crocks are elevated a little above the floor. The necessary stands can be made quite easily from ends of an orange box.

Hardware cloth stapled to the edges of a frame which has a beveled and sloping side is quite desirable as a stand for both the mash feeder and the water.

#### MILK DISH SUPPORT

Often milk or water is placed before chickens in open crocks or pans. These are frequently upset by chickens that try to stand on the edge while drinking. This can be prevented by nailing together in the form of a hollow square, four boards four or five inches wide and a little longer than the outside diameter of the crock. When the crock is placed within this square, the ledge on the crock should rest upon the edges of the boards forming the square. Birds stepping on the edge cannot turn it over even when it is empty. The picture shows how the milk is fur-

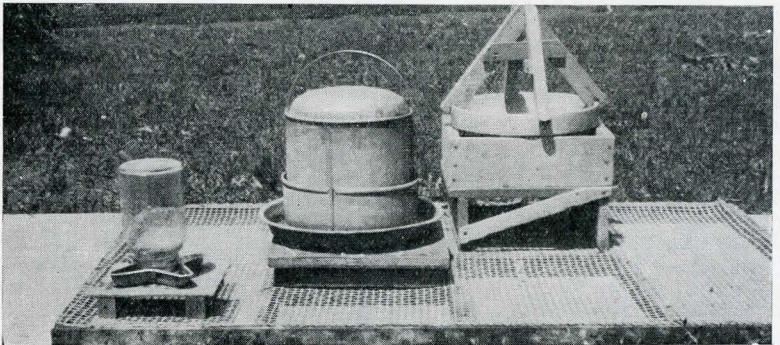

FIG. 11.—Feed and water stand made with top of hardware cloth.



ther protected by the hip rafters serving to prevent chickens getting into the crock.

#### SCREEN COVERED WATER STANDS FOR CHICKS

With many watering devices used for baby chicks, water or milk is often spilled and the litter surrounding the crocks becomes damp. With many of the feeding devices, the starting mash is billed out of the troughs or pans and scattered in the litter wherein the chicks scratch. Much dirt is picked up with such feed. A feed and water stand made by stapling hardware cloth onto the edges of a 4-inch frame is being used at the college. The hardware cloth serves as the top of the frame in which the water crocks and feed troughs are placed. Any spilled water or wasted feed simply falls thru the meshes of this screen. This feed or wet litter is thus entirely out of the reach of the baby chicks.

One side of the screen platform is usually made to set against the wall. Chicks can also be taught to roost on screen platforms if they are placed in the back part of the brooder room and near the stove. Much less floor litter is used where such screens are used. Providing such screens for the entire floor of the brooder house makes cleaning problems difficult.

#### DROP BOARDS AND ROOSTS

Drop boards are placed beneath the roosts of most modern poultry houses for the following reasons: Drop boards separate sleeping quarters from living quarters and thus add that much extra clean floor space to the chicken house. Drop boards make the removal of filth much easier and assist in developing regular habits of cleaning the houses.

Wire netting placed on the under side of roosts keeps the chickens out of their own filth even though the drop boards are not cleaned daily. This would help check the rapid spread of diseases during an epidemic. Keeping the hens off of the drop boards helps keep the eggs cleaner.

To prevent the accumulation of dead air above the drop boards during hot summer nights, arrangements should be made to slide the drop boards out from the wall a few inches.

It is easier to scrape the drop boards clean when the grain of the wood runs as illustrated in Figure 12. Shorter lengths of boards can also be used for making the drop boards when they are placed as illustrated. Drop boards are easier cleaned when made of matched flooring, well nailed and kept well oiled.



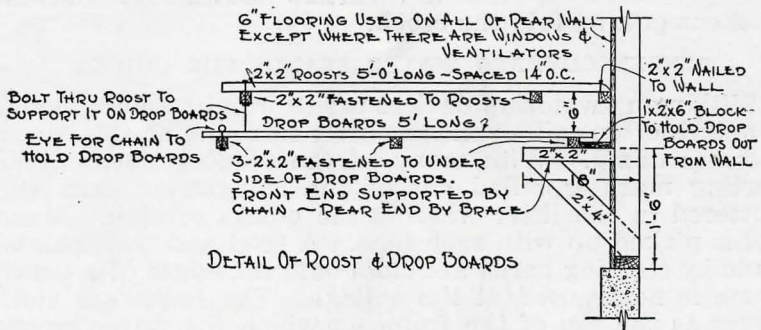

FIG. 12.—Cross section of plan of making drop boards and roosts movable without hinges.

Both dropping boards and roosts should be given a painting with wood preserving creosote at least once each year. This creosote and oiling usually prevents mites from getting a start.

The front of the drop boards is supported by chains which hang from the ceiling. The lower end of the chain is fastened to the 2"x2" which serves as the support of the drop boards. If the sections of a drop board are made 6 feet long, they are easily removed.

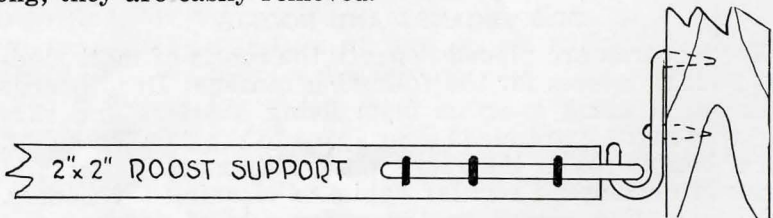

FIG. 13.—Hook and eye hinge.

Roosts are supported at the rear or hung from ceiling by chains. Hook and eye hinges for the rear roosts help make the roost more easily moved.

Roosts are 14" apart, made of 2"x2" strips with corners rounded, and run north and south or across the short way of drop boards. Eight to ten inches of roost should be allowed for each bird.

No hinges need be used as the front side of the roosts can rest on the drop board and the rear of roosts made to rest on a 2x2-inch cleat which is fastened onto the rear wall.

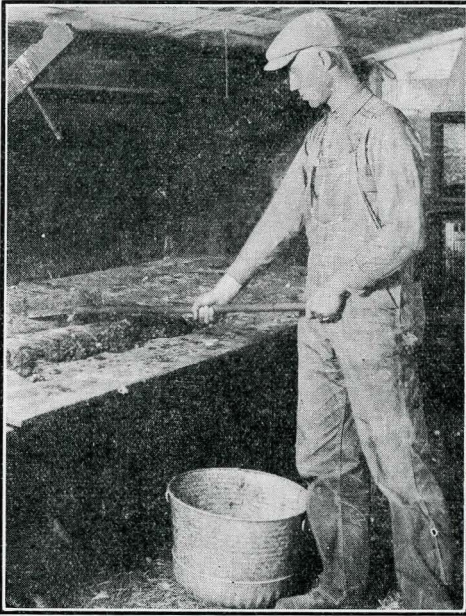

FIG. 14.—Drop board scrapers make cleaning easier.

be easily picked up and carried from the room if desired.

Heavy grease placed on and around this hinge makes a barrier over which mites cannot travel.

#### DROP BOARD SCRAPERS

Scrapers made light in weight somewhat like a hoe only from 12 to 16 inches long make easier work of the chore of cleaning the drop boards. Scrapers are on the market at very reasonable prices, one type of which is patterned after a scraper sold for pushing the snow from sidewalks. Drop boards are more easily cleaned with a scraper than with a shovel or hoe.

#### NESTS

Recommendations as to size of nests vary from 12 to 16 inches square depending upon the size of the breed.

One nest is usually recommended for each six hens. This is considered sufficient to prevent the breakage of eggs in the nests. Where trap nests are used one nest is needed for each four hens. Nests placed high above the floor encourage hens to use them for roosts thus making it more

#### HOOK AND EYE HINGE FOR ROOSTS

The hook can be either a piece of strap iron or round rod which is bent in the form of a hook and nailed or stapled to rear studding.

The eye is made from an iron rod  $\frac{3}{8}$ " to  $\frac{1}{2}$ " in diameter and bent in a long U form to fit around the end of one roost where it is stapled, allowing only an eye extending large enough to fit over the hook.

With such a hinge, a roost can be tilted from the front to allow easy cleaning of the drop boards. Also, the roosts can



difficult to produce clean eggs. As soiled eggs do not grade as high as clean eggs, careful poultrymen will provide plenty of clean nests. Nests placed on the floor take up expensive floor space needed for scratching.

Movable nests that slide into fixed frames with jump boards hinged so that nests can be closed are giving complete satisfaction. Building the nests six inches deep and 12 to 14 inches square is recommended. When the floor boards for the nests are left unnailed, they can then be easily removed for an annual creosote bath.

A popular material for padding nests is coarse and rather stemmy alfalfa or sweet clover. Such material fits easiest if applied when freshly cut. When dried, the coarse stems on the outside of the nests tend to hold the straw that is placed in the center.

#### ORANGE BOX NESTS

The orange box nest is popular with many because new ones can be added easily and old ones can be discarded in case of an invasion of mites. However, these nests are only  $11\frac{1}{2}$  inches square and thus hardly large enough for hens of the heavier breeds.

These box nests are made to stand on end or to lay on their sides. Two boards about 4 or 5 inches wide and  $11\frac{1}{2}$  inches long are held in place by nails being driven through the side boards. Such nests can easily be made to trap the hens as illustrated. When orange box nests are laid on their side they can be easily made by nailing one of the boards from the cover to the edge to retain the nest packing. Such nests must be covered to prevent chickens from getting on top. Otherwise the nests will become dirty from droppings falling through from above. Such nests are stacked one above another. The upper box is placed about 4 inches back of the lower box to thus make a jump board for the hens to use as they enter the nests.

#### COVERS FOR NESTS

Unless some kind of a sloping cover is made over nests and feeders hens will perch on any elevated level surface. This causes an accumulation of filth that is hard to clean. The following is a simple way of making movable sloping covers which can be placed on top of flat surfaces to prevent the perching of hens thereon.

A crate such as an orange box can be taken apart so as not to break the lumber. One end piece which usually is  $11\frac{1}{2}$  inches square can be sawed in two diagonally. The right angles of these two triangular pieces can then be set

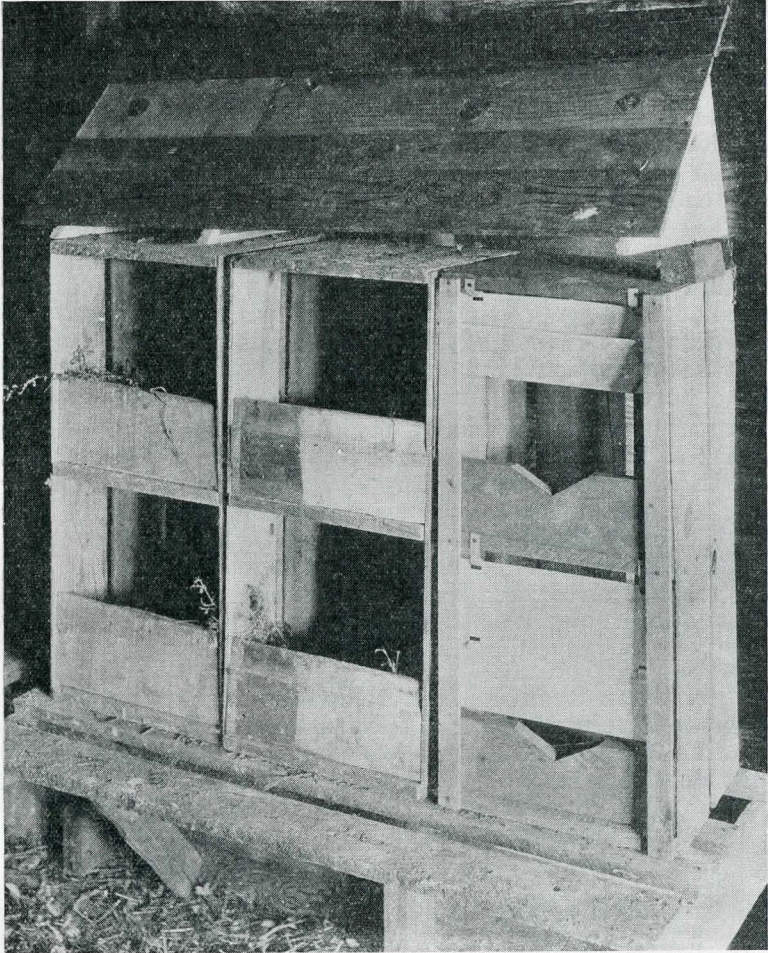

FIG. 15.—Orange boxes make cheap nests. The sloping cover is made removable.

on top of the nests with the thinner boards from the sides of the box nailed onto the longer slope of the triangular boards.

#### BROODY COOPS

Broodiness is a cause of considerable loss in egg production when the hens are not broken up promptly. A broody coop in each room of the chicken house makes it easy to jail the broody hens before they are permitted to sit and thus become difficult to break up. Broody hens come back



into lay quicker if well fed and made comfortable during the days they are confined. A slat bottom coop causes the hen to roost rather than sit, keeps her cleaner, and is more sanitary than solid floors. A feed trough and a water can should be hooked to the outer side of the broody coop to provide the hen with a complete ration. For this reason lath in place of wire netting is more popular for side walls of the broody coops.

A watering can which hooks onto a wire fastened to the edge of a coop can be made as follows: Make two nail holes about 2 inches apart near the top of the can. Insert a short piece of bailing wire through these holes. Twist these ends together with a pair of pliers. This doubled wire can be bent into a hook which will hold the can of water in position where the hens can drink.

A small and light feed trough can be made of quarter-inch box lumber. A box trough made three inches deep and three inches wide is very light and handy. By wrapping a piece of bailing wire around this trough and twisting the ends together hooks can thus be formed so the trough can be hooked in place outside the broody coop. Dry mash, germinated oats, and scratch feed can thus be fed to the broody hens regularly.

#### GRAIN BINS

Much time is saved by having the feed supply stored conveniently in or near the chicken house. For ease of cleaning these should not take up floor space. Bins can be built on the sides or in the corners of the chicken house. Plans for building grain bins are included in the blue print of the Nebraska plan poultry house.

#### GREEN FEED RACK

Green cured alfalfa hay has come into favor in Nebraska as a feed for hens during the winter months. The practice of placing such hay on the floor cannot be recommended for sanitary reasons. The most feed value can be secured from alfalfa hay if it can be run through a feed chopper and cut into short lengths. Such fine cut hay can be placed in the feed troughs on top of the dry mash. When such feed choppers are not available, then the hay can be placed in racks.

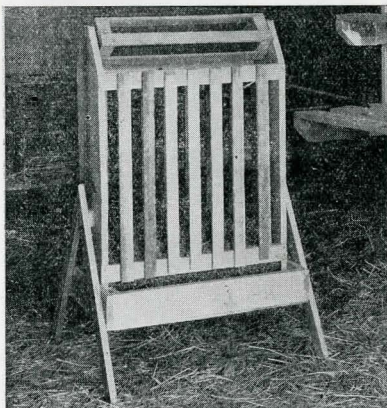

FIG. 16.—An inexpensive and movable rack for feeding alfalfa hay during the winter months.

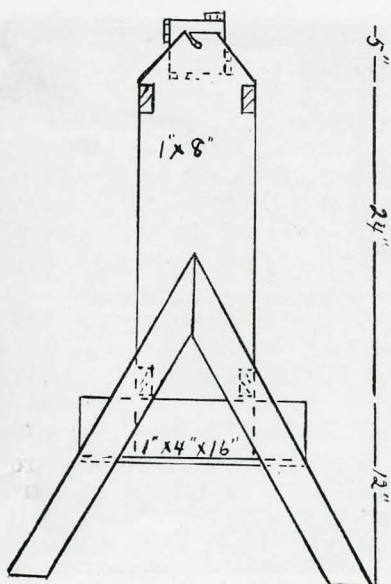

FIG. 17.—End view of a movable rack.

### GERMINATED OATS

Germinated oats as a regular feed for laying hens and growing chicks is rapidly gaining in popularity. At the College of Agriculture oats are soaked in large garbage cans and drained by tying a gunny sack over the top of the can and turning the can over on its side. The soaked oats are then spread over the cement floor in the basement of the feed house where they can be stirred and sprinkled with water as often as desired. During the winter the oats are piled several inches deep but during the hottest part of the summer they must be spread thinner and given more water.

Four or five wooden candy pails with several holes bored in the bottoms for draining is the only equipment needed for germinating enough oats for a flock of 400 hens. During the summer these pails can be kept on a rack in the shade of a tree or the north side of a building which is located near the water supply. During the winter the buckets need to be placed near a furnace where a temperature of 45 to 60 degrees is maintained.

To avoid oats molding while germinating some people use a teaspoon of formaldehyde to the water that is added



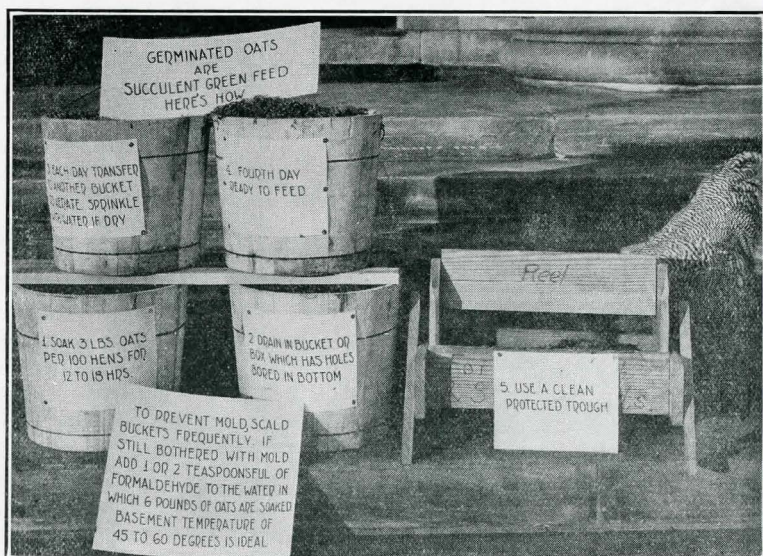

FIG. 18.—Modern equipment for germinating oats.

to soak three gallons of oats. Cleaning of all buckets used is also necessary.

#### ARTIFICIAL LIGHTS FOR LAYERS

A number of Nebraska poultrymen have installed electric lights in their chicken houses. These artificially illuminate the poultry houses and lengthen the working day during the winter months. As yet no information has been collected in Nebraska as to the amount of light these poultrymen find necessary.

The Colleges of Agriculture of New York and Ohio have studied this problem. They have printed bulletins on this subject. Briefly their recommendations are as follows:

1. A reflector is recommended which is 16 inches in diameter with 4 inches rise from edge to center.
2. The lights and reflectors are hung 6 feet above the floor.
3. One 40-watt lamp with reflector for each 200 square feet of floor area is recommended.
4. Lights should be placed midway between front of the drop boards and the front of house.
5. In a 20x20-foot room, two lights are necessary. The units should be 10 feet apart and 5 feet from the edge of the room.

### A SUN PARLOR AND PORCH

Scientists have discovered that the ultra-violet rays of the sun are filtered out of the sunshine that passes through glass. There is no question but that the direct rays of the sun are beneficial to the health of a poultry flock. The lack of this direct sunshine for the breeding flock reduces vitality of the birds making them susceptible to nutritional roup. The use of direct sunshine has increased egg production. With chicks that have become affected with rickets due to malnutrition direct sunlight soon effects a cure. As so many of our poultry keepers find it practical to keep their hens confined to the chicken houses during the winter, arrangements are desired whereby the hens are able to absorb these beneficial rays. Some will get this desired sunlight by open front poultry houses or by doors and curtains on the south side of house. Others will be interested in a sun parlor or sun porches placed on the sunny side of the poultry house. This same sun parlor could be easily moved to the front of a brooder house when it is desired to get young chicks out into the open sunshine.

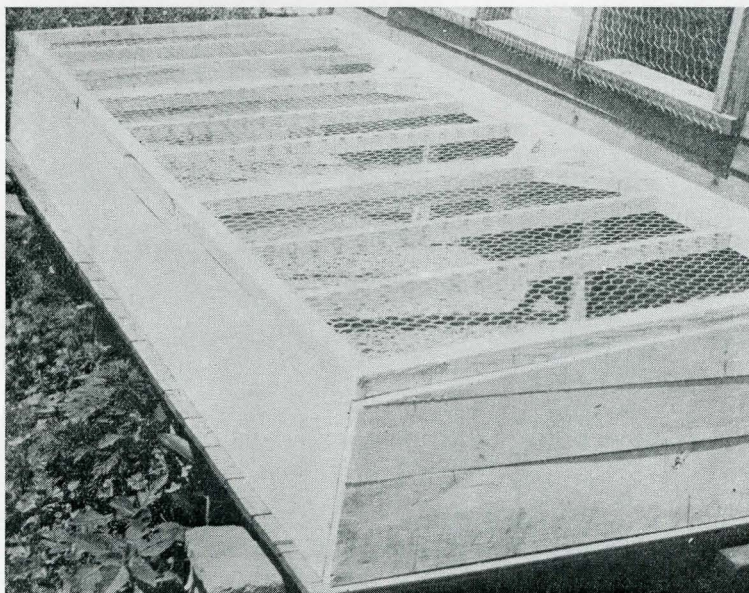

FIG. 19.—The top of the sun parlor is screened with 1 inch poultry netting to allow direct sunshine to enter.



A sun parlor four feet wide and ten feet long with sides and front built of wood and top protected with muslin covered frames has been made for experimental use at the college poultry plant. This sun parlor has a floor space 4 by 10. It is 2 feet high on the open side which fits up against the front of the brooder house. It is 14 inches high on the low or south side. This sun parlor should be built so it can be moved to the places where it is most needed.

#### HOT WEATHER ROOSTING SHEDS

At the College of Agriculture, cheap roosting sheds have been provided for the young turkeys after they are well feathered. Similar hot weather sheds will prove useful where the brooder houses are over-crowded or where one desires to keep a group of breeding cockerels or capons separated from the rest of the young stock. Complaints of summer roup in young turkeys or chickens have not arisen when this type of open sheds were used.

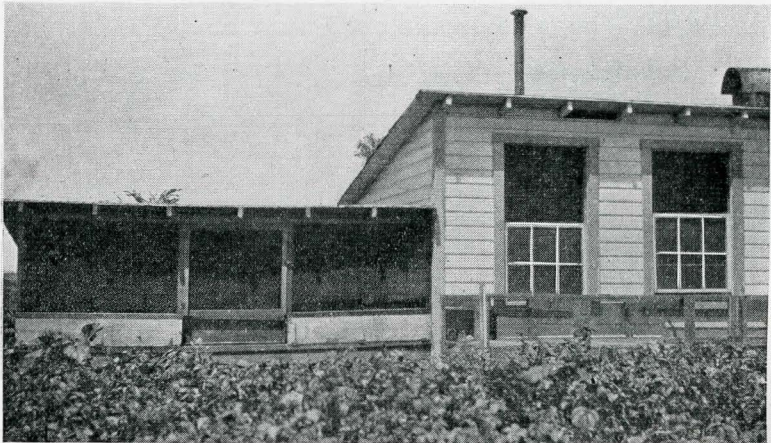

FIG. 20.—Suggested dimensions for building these hot weather roosting sheds are to be found in Extension Service circular No. 733.

#### FEED SCREENS

Much feed is wasted on many poultry farms where feed is ground at home and no method of separating the coarser ground feed from the fine is provided. Sieves made by nailing hardware cloth to frames and so arranged that ground feeds can flow over these screens as they come from the grinders, are a very handy part of the feed room equip-

ment. These screens need not be over 15 to 18 inches wide and 30 inches long. Hardware cloth that has 6 meshes to the inch is recommended for sieves which are to be used in separating the fine from the coarser part of ground corn.

#### SHIPPING CRATES

In shipping or hauling breeding stock, colds and roup often develop because of the exposure of the birds while in transit. Most breeders prefer a crate about 12 to 15 inches wide and 1½ to 2 feet long and about 2 to 2½ feet high for such shipments. To keep express charges at a minimum, light lumber should be used. Since the cardboard cartons have come into common use, these empty boxes can be often secured from stores and converted into light, roomy, well ventilated shipping crates. Short nails with large heads, such as are used for roofing paper, can be used to nail through the upper part of the box into a frame of 1"x2" lumber which just fits around the outside of the box. Lath can then be used to cover the top of the coop after the bird is enclosed. For additional ventilation several holes which are too small to let a fowl's head through can be cut on each side of the box.

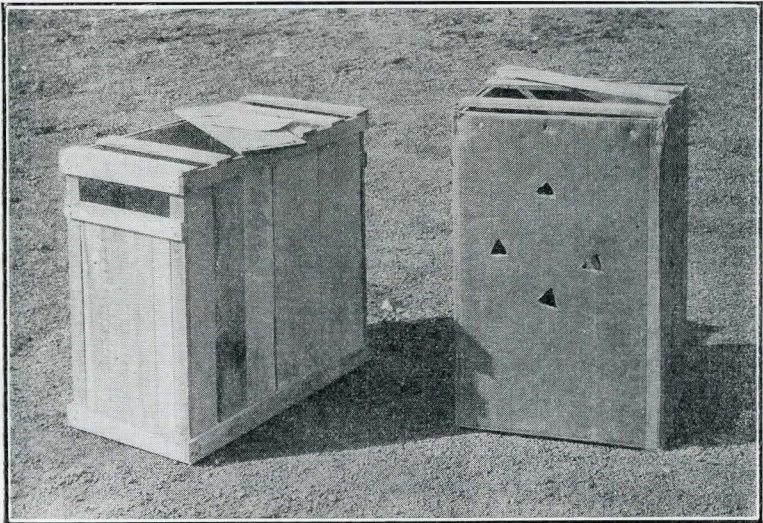

FIG. 21.—Shipping crates that are comfortable and well ventilated.



### MARKETING CRATE

Poultrymen who do not have many broilers to market at one time will need a small light crate in which to haul their broilers to market. A coop which will fit these needs can be made from a lettuce crate and an orange box.

The thin boards from the orange box are removed and nailed to the bottom of a lettuce crate to form the solid bottom. To hold this bottom more securely, cleats should

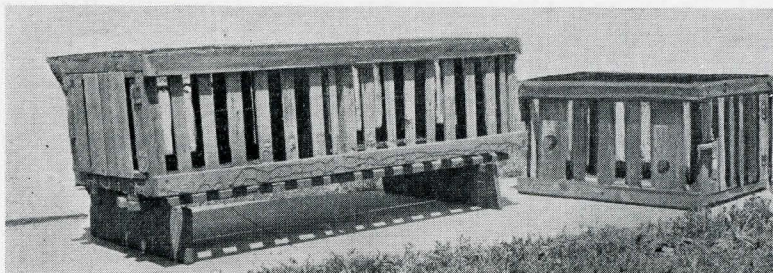

FIG. 22.—Combination marketing crate and broody coop to be placed under the trees. Made from box lumber.

be nailed through the bottom like the tops of apple boxes are fastened.

The extra bottom boards of the lettuce crate are used to make the sides and top. The cracks must be narrow enough not to allow any broilers to crowd through. Two inches is suggested as the maximum width of these cracks.

One of the side boards from the orange box can be used as that part of the top fixed removable to slide out when chicks are being put into or taken from the crate or a hinged door can be made in one end of the crate.

### CATCHING HOOKS

In selecting the best hens for a breeding pen or catching the hen that appears to have some physical defect or that is off feed, a No. 9 wire bent into a catching hook is very handy. A heavy piece of wire and a pair of pliers is all that is needed for making such a hook. Some experience in using these hooks is necessary before a person is handy with them. As a rule, hooks from 4 to 5 feet long are easiest to handle. To prevent injury to fowls, the end should be bent as illustrated.

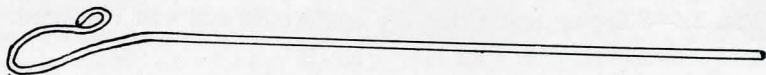

FIG. 23.—The wire catching hook.

A wire hoop about 18 inches in diameter covered by a light cord netting such as is used for catching minnows can be fastened to a handle and used in the poultry yard as a catching net.

#### PEDIGREE BASKETS

The eggs from an individual hen can be placed in pedigreed baskets just before they are hatched, when pedigree records are desired. A few people desire to mark the chicks separately from their different breeding pens and may be able to use such baskets.

These baskets are made of hardware cloth about 6 inches square and 3 inches deep. Such size will hold 4 to 6 eggs or about the number one hen in heavy production will lay in a week's time.

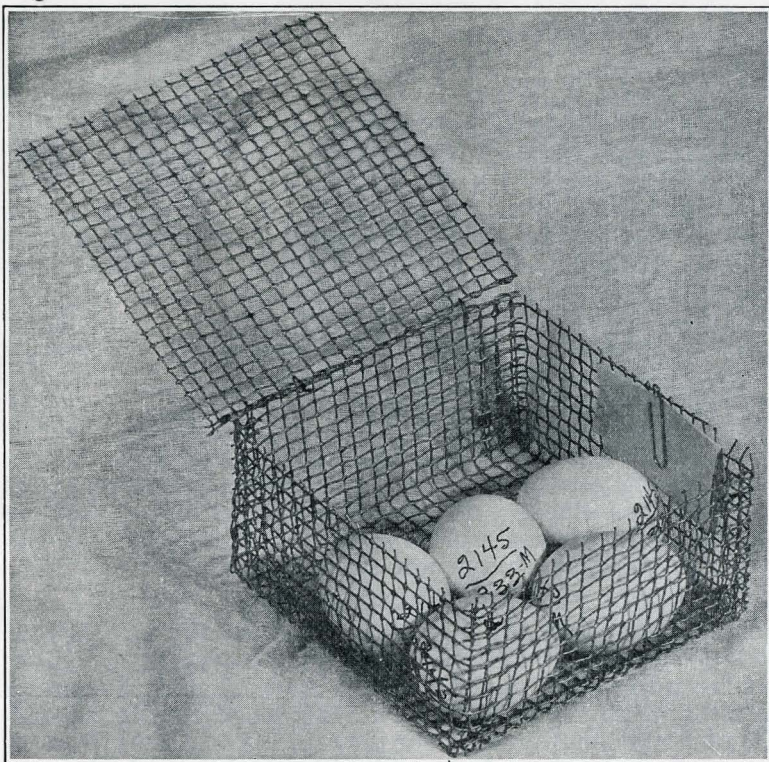

FIG. 24.—A home made pedigree basket.



**WIRE PANELS**

Poultrymen find frequent use for temporary pens and light weight gates for closing of runs. A lesson in the use of panels can be learned from the hog man. Light weight panels covered with a light poultry fencing can be made in 10 and 12-foot lengths which will prove very useful about the poultry plant. Several of these panels can be wired together to make temporary pen where broilers can be fattened, or where young chicks can be kept separated from older stock. For older stock it is best to make these panels about 5 feet high. The uprights can be 2—2"x2"x5', the bottom a 1"x4"x10', and the braces 2—1"x3"x12'. Such panels can be made for about \$1.00 and so constructed should last for years if ordinary careful treatment is given them .

**BILL OF MATERIAL:**

1 bottom .....	1"x4"x10'
2 uprights .....	2"x2"x 5'
2 braces .....	1"x3"x12'

**CLEAN YARDS FOR CHICKS**

This bulletin has thus far explained how to build poultry house and yard equipment which aids in keeping the feed and water clean. Such equipment will not prevent the filth borne diseases and parasites from attacking fowls if they range on ground which has become infested by long continued use. To keep young chicks on safe ground requires that one of two methods be adopted. Either the brooder houses or range shelters must be moved each year to new and clean ground or a system of alternating yards must be established.

The ten by twelve foot Nebraska type brooder house is built on four by four skids with the idea that it be moved to a different part of the range each year. On commercial poultry plants chicks are often brooded in larger units in one run of the house used for hens. This system is described in Nebraska extension circular 1462.

**RANGE SHELTER SHEDS**

Where the same brooder house is used for two broods of chicks or for starting a brood of turkeys after chicks have been brooded, range summer shelter sheds become a necessity. Extension circular No. 733 describes the Nebraska type 8'x20' shelter shed for turkeys. For chickens, summer roosting sheds are built with either gable or shed roofs. Some have wire floors. Others are equipped with dropping boards. Sheds are popular because with them pullets can be moved to clean range where the evil effects of filth borne diseases and parasites can be avoided.