

University of Nebraska - Lincoln

DigitalCommons@University of Nebraska - Lincoln

---

Environmental Engineering Theses and  
Graduate Student Research

Environmental Engineering Program

---

April 2011

## Design and Modeling of Infrastructure for Residential and Community Water Reuse

Shannon M. Killion

University of Nebraska-Lincoln, skillion1@gmail.com

Follow this and additional works at: <https://digitalcommons.unl.edu/envengdiss>



Part of the [Environmental Engineering Commons](#)

---

Killion, Shannon M., "Design and Modeling of Infrastructure for Residential and Community Water Reuse" (2011). *Environmental Engineering Theses and Graduate Student Research*. 2.  
<https://digitalcommons.unl.edu/envengdiss/2>

This Article is brought to you for free and open access by the Environmental Engineering Program at DigitalCommons@University of Nebraska - Lincoln. It has been accepted for inclusion in Environmental Engineering Theses and Graduate Student Research by an authorized administrator of DigitalCommons@University of Nebraska - Lincoln.

Design and Modeling of Infrastructure for Residential and Community Water Reuse

By

Shannon M. Killion

A THESIS

Presented to the Faculty of  
The Graduate College at the University of Nebraska  
In Partial Fulfillment of Requirements  
For the Degree of Master of Science

Major: Environmental Engineering

Under the Supervision of Professor John S. Stansbury

Lincoln, Nebraska

May, 2011

# DESIGN AND MODELING OF INFRASTRUCTURE FOR SUSTAINABLE URBAN WATER SYSTEMS

Shannon M. Killion, M.S.

University of Nebraska, 2011

Adviser: John S. Stansbury

Water scarcity and deteriorating water infrastructure are of growing concern in the United States. The conventional methods of treating and transporting potable water and wastewater are being challenged as new technology creates opportunities for water reuse. Instead of simply replacing the current infrastructure for centralized treatment systems, alternatives such as dual distribution and decentralized treatment systems are being investigated as more sustainable alternatives.

Implementing dual distribution systems leads to benefits such as reducing the amount of water treated to potable standards and reducing freshwater withdrawals. A dual distribution system allows the non-potable demands to be shifted from the potable water supply to a lower quality water source such as greywater, rainwater, or reclaimed wastewater. Removing demands such as fire flow, irrigation, laundry, and toilet flushing from the potable demand reduces the demand and allows potable water to be treated to higher water quality standards in a more efficient and cost effective way. A dual distribution system allows water to be treated to the levels necessary for the end use instead of treating all water to drinking water standards.

Before water reuse can be widely implemented, the infrastructure requirements for dual distribution need to be understood. Once the infrastructure requirements are

known, they can be evaluated using economic and life-cycle analyses to determine the overall feasibility of the systems.

The infrastructure requirements are determined through the use of EPANET 2, a hydraulic model developed by the United States Environmental Protection Agency. Scenarios utilizing systems such as using untreated greywater for subsurface irrigation require the least amount of infrastructure. As the complexity of the system increases so does the required infrastructure. In this study, the infrastructure requirements are determined for the following scenarios: greywater and rainwater for non-potable use in single-family residences, rainwater for non-potable use in an apartment building, and reclaimed wastewater use in a community.

## **Acknowledgments**

This thesis would not have been possible without the support of my family, friends, and professors.

To my family and friends, if not for your support and encouragement during my college career, I would not have overcome the many challenges I faced along the way. I'm thankful you were all there for me, not only to support me during the difficult moments, but also to share in the better ones.

To Dr. Stansbury, Dr. Bartelt-Hunt, and Dr. Zhang, thank you all for your guidance and support as I completed my research. I am especially grateful for your flexibility in allowing me to finish much of my research while studying in Sweden. It was truly an inspiring and life-changing experience.

To my undergraduate professors Dr. Jones and Dr. Schulte, thank you for urging me to pursue a graduate degree. Despite my original reservations, I'm now very thankful I took your advice.

To my colleagues Derek Gardels and J. Brett Sallach, I'm indebted to you both for your help in completing this thesis. Derek, thank you for your patience and flexibility while we worked together and communicated across two continents. Brett, thank you for all the time you spent being my sounding board while in Sweden. By the end of my time abroad, I think you knew as much about my research as I did.

Finally, I would like to thank the Nebraska Pump Company and Lincoln Water Systems. The insight into the pump and water industry provided by these two organizations proved invaluable as I completed my research.

## Table of Contents

Acknowledgments.....	iv
List of Figures.....	viii
List of Tables.....	ix
1 Introduction.....	1
1.1 EPA Green Buildings Project.....	1
1.2 Goals of Decentralized Drinking and Wastewater Technologies and Systems ...	1
1.3 Objective.....	2
1.4 Organization of Thesis.....	2
2 Literature Review.....	3
2.1 Scarcity of Water.....	3
2.2 Current State of Water Infrastructure in the United States.....	4
2.3 Conventional Water Distribution Systems.....	5
2.3.1 Potable Water Quality.....	7
2.3.2 Water Demand.....	9
2.3.3 Wastewater Treatment.....	10
2.4 Dual Distribution Systems.....	12
2.5 Greywater Systems.....	13
2.5.1 Greywater Sources.....	14
2.5.2 Greywater Quality.....	14
2.5.3 Greywater Treatment.....	15
2.5.4 Greywater Quantities.....	16
2.5.5 Greywater Uses.....	17
2.5.6 Health Concerns Associated with Greywater Use.....	17
2.6 Rainwater Systems.....	18
2.6.1 Collection of Rainwater.....	19
2.6.2 Rainwater Quality.....	19
2.6.3 Rainwater Quantities.....	21
2.6.4 Rainwater Use.....	22
2.6.5 Health Concerns Associated with Rainwater Use.....	22
2.7 Reclaimed Water.....	22

2.7.1	Reclaimed Water Quality.....	23
2.7.2	Reclaimed Water Quantities .....	25
2.7.3	Reclaimed Water Uses .....	26
2.7.4	Concerns Associated with Reclaimed Water Use.....	26
2.8	Decentralized Water and Wastewater Treatment Plants .....	27
2.8.1	Advantages of Decentralized Treatment.....	28
2.8.2	Disadvantages of Decentralized Water Treatment .....	29
2.8.3	Decentralized Treatment Technologies .....	30
3	Methods .....	31
3.1	Water Demand and Fixture Utilization .....	31
3.2	Hydraulic Model .....	33
3.2.1	EPANET 2 Model Validation.....	34
3.2.2	Sensitivity Analysis of Hazen-Williams Equation .....	34
3.3	Modeling Individual Residence Reuse Systems .....	35
3.3.1	Definition of a Typical Residence .....	36
3.3.2	Greywater Reuse System with Simple Greywater Collection and No Treatment.....	37
3.3.3	Greywater Reuse System with Complex Greywater Collection and Treatment.....	44
3.3.4	Greywater Reuse System with Rainwater Harvesting .....	51
3.4	Apartment Building.....	71
3.4.1	Rainwater Harvesting.....	73
3.4.2	EPANET 2 Model for Apartment Building .....	80
3.4.3	Rainwater Benefits.....	84
3.5	Community Scale .....	84
3.5.1	Definition of Typical Community .....	85
3.5.2	Determining Community Water Demands .....	87
3.5.3	Conventional Distribution System.....	96
3.5.4	Reclaimed Distribution System .....	99
3.5.5	Modified Potable Distribution System.....	102
3.5.6	Additional Infrastructure Requirements for Community.....	104

3.5.7	Benefits of Large Scale Reclaimed Water Use.....	107
3.6	Implementation in Different Regions.....	108
4	Results and Discussion .....	109
4.1	Results .....	109
4.1.1	Greywater Reuse.....	109
4.1.2	Rainwater Harvesting.....	110
4.1.3	Reclaimed Water Reuse .....	111
4.2	Discussion .....	111
5	Conclusions and Recommendations.....	112
5.1	Conclusions .....	112
5.2	Recommendations for Future Study and Analysis.....	112
6	References .....	113
7	Appendices .....	119
	Appendix A Directions for EPANET 2 Models .....	120
	Appendix B Square Footage of Apartment Roof Catchment Areas .....	138
	Appendix C Diagrams for the Number of Downspouts Required per Apartment Catchment .....	140
	Appendix D Diagram of Apartment Building with All Plumbing Shown.....	145
	Appendix E Residential Water Use Pattern .....	147
	Appendix F EPANET Pattern Multipliers for Community Models.....	149
	Appendix G Design Guides for Water Reuse .....	153



## List of Figures

Figure 2.1 Breakdown of Indoor Residential Use by Fixture .....	9
Figure 2.2 Breakdown of Greywater Production in the United States. ....	17
Figure 3.1 Floor Plans for Typical Single-Family Home. ....	36
Figure 3.2 Indoor Greywater Plumbing for the Simple Greywater Reuse System.....	37
Figure 3.3 Outdoor Subsurface Irrigation Layout for Houses in Tampa and Seattle. ....	38
Figure 3.4 Outdoor Subsurface Irrigation Layout for Houses in Scottsdale.....	39
Figure 3.5 Outdoor Subsurface Irrigation Layout for Houses in Omaha .....	39
Figure 3.6 Screenshot of the Simple Greywater Collection Scenario in EPANET 2. ....	41
Figure 3.7 Greywater Collection and Distribution System for Complex Greywater Collection with Treatment. ....	45
Figure 3.8 EPANET 2 Layout for Complex Greywater System with Treatment. ....	48
Figure 3.9 Maximum Water Age for the Complex Greywater System with Treatment..	49
Figure 3.10 Plumbing for Greywater Reuse System with Rainwater Harvesting. ....	52
Figure 3.11 Layout of Filter and First Flush Diverter for Rainwater Harvesting.....	55
Figure 3.12 Residential Roof Catchments and Rainwater Collection Points .....	56
Figure 3.13 Residential Underground Piping Layout .....	62
Figure 3.14 Definition of Terminology Used in Table 3.25 through Table 3.28. ....	64
Figure 3.15 EPANET 2 Model for Rainwater Harvesting and Greywater Reuse Scenario. ....	68
Figure 3.16 Apartment Building Layout.....	72
Figure 3.17 Individual Apartment Layouts.....	72
Figure 3.18 Horizontal Rainwater Collection System for Apartment Building. ....	77
Figure 3.19 EPANET 2 Layout for One Floor of the Apartment Building .....	82
Figure 3.20 Layout of Collection System for Apartment Rainwater Harvesting .....	83
Figure 3.21 Satellite View of the Neighborhood Used in the Community Scenario.....	87
Figure 3.22 Pipe Network for Conventional Community Model Showing Pipe Diameters.....	97
Figure 3.23 Community Reclaimed Water Pipe Network and Pipe Diameters.....	101
Figure 3.24 Community Potable Pipe Network Showing Pipe Diameters .....	103

## List of Tables

Table 2.1 United States Primary Drinking Water Regulations.....	8
Table 2.2 United States Secondary Drinking Water Regulations.....	9
Table 2.3 Typical Characteristics of Municipal Wastewater.....	12
Table 2.4 Characteristics of Greywater .....	15
Table 2.5 National Average of Greywater Production Broken Down by Fixture. ....	16
Table 2.6 Rainwater Quality.....	20
Table 2.7 Minimum Water Quality Guidelines and Treatment Options for Stormwater Reuse .....	21
Table 2.8 State Guidelines for Unrestricted Reclaimed Water Use.....	25
Table 3.1 Residential Fixture Utilization Values Per Capita Per Day.....	32
Table 3.2 Comparison of Conventional and High Efficiency Flow Rates. ....	32
Table 3.3 National Average Residential Per Capita Demand.....	37
Table 3.4 Minor Loss Coefficients .....	40
Table 3.5 Additional Indoor Infrastructure for the Simple Greywater Reuse Scenario. ..	42
Table 3.6 Additional Outdoor Infrastructure for the Simple Greywater Reuse Scenario in Seattle and Tampa. ....	42
Table 3.7 Additional Outdoor Infrastructure for the Simple Greywater Reuse Scenario in Scottsdale .....	43
Table 3.8 Additional Outdoor Infrastructure for the Simple Greywater Reuse Scenario in Omaha .....	43
Table 3.9 Materials List for Greywater Collection and Treatment Scenario.....	50
Table 3.10 Capacity of 3, 4, and 12 inch Diameter Schedule 40 PVC Pipe.....	54
Table 3.11 Intensities for 60 minute, 100 year design storm.....	56
Table 3.12 Residential Roof Catchment Areas.....	57
Table 3.13 Allowable Projected Roof Collection Area for Gutters by Study City Based on the Appropriate Rainfall Rate. ....	58
Table 3.14 Allowable Projected Roof Collection Area for Downspouts by Study City Based on the Appropriate Rainfall Rate .....	58
Table 3.15 Seattle Required Downspout and Gutter Diameters .....	59
Table 3.16 Scottsdale Required Downspout and Gutter Diameters .....	59
Table 3.17 Omaha Required Downspout and Gutter Diameters .....	59
Table 3.18 Tampa (4.2 in/hr) Required Downspout and Gutter Diameters.....	59
Table 3.19 Required Amount of Storage Capacity for First Flush Diverters and Corresponding Length of 3-inch PVC Pipe.....	61
Table 3.20 Frost Penetration in Study Cities .....	61
Table 3.21 Seattle (0.010 gpm/ft <sup>2</sup> ) Required Underground Pipe Diameter Using 1/8 in/ft Pipe Slope.....	63
Table 3.22 Scottsdale (0.023 gpm/ft <sup>2</sup> ) Required Underground Pipe Diameter Using 1/8 in/ft Pipe Slope.....	63

Table 3.23 Omaha (0.037 gpm/ft <sup>2</sup> ) Required Underground Pipe Diameter Using 1/4 in/ft Pipe Slope.....	63
Table 3.24 Tampa (0.044 gpm/ft <sup>2</sup> ) Required Underground Pipe Diameter Using 1/8 in/ft Pipe Slope.....	63
Table 3.25 Underground Pipe Requirements for Seattle .....	64
Table 3.26 Underground Pipe Requirements for Scottsdale.....	64
Table 3.27 Underground Pipe Requirements for Omaha.....	65
Table 3.28 Underground Pipe Requirements for Tampa.....	65
Table 3.29 Materials for Rainwater Harvesting Required by All Locations .....	66
Table 3.30 Rainwater Harvesting Materials Required for Seattle and Scottsdale .....	66
Table 3.31 Rainwater Harvesting Materials Required for Omaha .....	66
Table 3.32 Rainwater Harvesting Materials Required for Tampa.....	66
Table 3.33 Indoor Plumbing Material Requirements for Rainwater Harvesting and Greywater Reuse Scenario.....	69
Table 3.34 Outdoor Plumbing Material Requirements for Subsurface Irrigation in Rainwater Harvesting and Greywater Reuse Scenario in Seattle.....	69
Table 3.35 Outdoor Plumbing Material Requirements for Subsurface Irrigation in Rainwater Harvesting and Greywater Reuse Scenario in Scottsdale.....	70
Table 3.36 Outdoor Plumbing Material Requirements for Subsurface Irrigation in Rainwater Harvesting and Greywater Reuse Scenario in Omaha .....	70
Table 3.37 Outdoor Plumbing Material Requirements for Subsurface Irrigation in Rainwater Harvesting and Greywater Reuse Scenario in Tampa.....	70
Table 3.38 Cistern Sizes by Location for the Apartment Building.....	74
Table 3.39 Overview of Apartment Gutter and Downspout Requirements by City.....	75
Table 3.40 Materials Required for Apartment Rainwater Harvesting System in All Study Cities.....	78
Table 3.41 Additional Apartment Outdoor Plumbing Materials Required for Seattle .....	79
Table 3.42 Additional Apartment Outdoor Plumbing Materials for Scottsdale .....	79
Table 3.43 Additional Apartment Plumbing Materials for Omaha .....	80
Table 3.44 Additional Apartment Plumbing Materials for Tampa.....	80
Table 3.45 Additional Indoor Infrastructure for Apartment Building .....	84
Table 3.46 Breakdown of Buildings in the Community Scenario .....	86
Table 3.47 Overview of Apartment Complexes in Community Scenario .....	89
Table 3.48 Apartment Complex Water Demands.....	89
Table 3.49 Non-Residential Water Demands for Community Scenario.....	90
Table 3.50 Breakdown of Non-Residential Demands to Potable and Non-potable Demands .....	91
Table 3.51 Peak flow rates for Non-Residential Buildings in Community .....	92
Table 3.52 Square Footage of Buildings in Community and Required Fire Flow Rates.	95

Table 3.53 Infrastructure Requirements for Community Potable Water Distribution System.....	105
Table 3.54 Service Line and Indoor Plumbing Requirements for Single-Family Residence. ....	106
Table 3.55 Service Line and Indoor Plumbing Requirements for Community Apartment Buildings. ....	106
Table 3.56 Service Line and Indoor Plumbing Requirements for Community Non-Residential Buildings. ....	107
Table 4.1 Summary of Rainwater Harvesting Materials for a Single-Family Home .....	110

## **1 Introduction**

### **1.1 EPA Green Buildings Project**

A proposal titled “Advanced Decentralized Water/Energy Network Design for Sustainable Infrastructure” was submitted and subsequently funded by the United States Environmental Protection Agency (USEPA). The two main goals of the project are to 1) create and analyze water-saving decentralized drinking and wastewater technologies and combine them with renewable energy and energy recovery/saving technologies and 2) incorporate the technologies into green building, community design, and construction.

The project is divided into three main areas. The first area focuses on the development of water-saving decentralized water and wastewater technology and water reuse systems. The focus of the second area is researching renewable energy and energy recovery/saving technologies. The third area incorporates the results from the first two areas into the design of buildings and communities to obtain maximum energy and water efficiency. This thesis deals with the first area, decentralized water and wastewater technologies, and water reuse.

### **1.2 Goals of Decentralized Drinking and Wastewater Technologies and Systems**

The goal of developing decentralized drinking and wastewater technologies is to increase potable water quality, water reuse, and energy efficiency while decreasing freshwater withdrawals. The implementation of decentralized and reuse systems reduces the need for extensive pipe infrastructure for drinking and wastewater systems. For example, supplying fire flows with reclaimed water reduces piping and treatment requirements. In addition, the need for large centralized drinking and wastewater treatment plants will be reduced. Water reuse systems can also reduce the need for water

and wastewater treatment and, therefore, may provide reduced associated energy and material costs. The specific area investigated here is the infrastructure requirements for water reuse systems.

### **1.3 Objective**

The objective of the first focus area for the EPA Green Buildings project is to evaluate decentralized water and wastewater technology and the feasibility of water reuse. The objective of this thesis is to develop models for varying scales of water reuse (i.e. greywater reuse, rainwater harvesting, and reclaimed wastewater), identify the required infrastructure, and then compare the results to conventional infrastructure requirements.

### **1.4 Organization of Thesis**

The remainder of this thesis includes the following information and details. Chapter 2 is a literature review which focuses on the conventional, reclaimed, potable water, greywater, and rainwater systems and their respective demands and water quality. Chapter 3 discusses the hydraulic model used to model the different scenarios and the methods used in the model development. Chapter 4 contains the results of the analysis and a discussion about each system. Conclusions and recommendations are located in Chapter 5.

## **2 Literature Review**

### **2.1 Scarcity of Water**

A country is considered to be water-scarce if its annual renewable supply of freshwater is less than 264,170 gallons (1,000 m<sup>3</sup>) per capita. Water scarcity leads to problems such as food shortages, decreased economic development, regional water conflicts, and environmental degradation. Water-scarce countries can be divided into two categories. The first category includes countries with physical water scarcity meaning that even with the highest efficiency and productivity, there is not enough water to meet the future needs. The second category includes countries with economic water scarcity. They have enough water resources but they lack the money to use or access the water, or they face critical financial and development capacity issues. Countries with physical water scarcity include Northern Africa, the Middle East, and areas of China. Countries with economic water scarcity are Central and South America, most of Africa, Southeast China, and Australia (Asano 2007).

In the United States, several water resource regions that have potential limitations concerning water supply with respect to dependability and adequacy are the Missouri Basin, Rio-Grande Region, Upper and Lower Colorado River Basin, Texas-Gulf, California, and the Great Basin. Some areas are using water at unsustainable rates while other areas are dependent on groundwater mining (Asano 2007). The U.S. Geological Survey states that approximately 35% of water use in the United States is unsustainable (Hammer and Hammer 2008).

The United States is the largest municipal water consumer in the world. In non-conserving single family residences, the average water use in 2000 was 100

gallons/capita-day (gpcd) (380 liters/capita-day, lpcd), but could reach up to 264 gpcd (1000 lpcd) in semi-arid and hot arid regions of the US. The water use figures mentioned above are for direct household use. If the water used outside of the city to raise crops and livestock, to produce electricity, paper, construction materials, biofuels, oil, etc., is considered for each person, the water use rises to 509 gpcd (1,928 lpcd) (Novotny et al. 2010).

## **2.2 Current State of Water Infrastructure in the United States**

The majority of the water infrastructure in the United States was built after World War II. In an USEPA survey, it was reported that 30% of pipes in systems serving 100,000 or more people are between 40 and 80 years old, and around 10% of the pipes were more than 80 years old. Pipes can last from 15-100 years depending on the material and the environment. USEPA reports that the pipe material is a better indicator of failure than pipe age. In addition, the average service life for treatment plants is 20-50 years before they need to be expanded or rehabilitated (USEPA 2010b).

In 2002, USEPA conducted a Gap Analysis to approximate the gap in funding between projected water infrastructure needs and current spending. The analysis included both capital and operations and maintenance costs. The study found that the 20-year gap (2000 to 2019) with no revenue growth for clean water is \$122 billion in 2001 dollars. For drinking water, the gap for capital funding was estimated to be \$102 billion. The operation and maintenance costs for clean water is estimated at \$148 billion and at \$161 billion for drinking water (USEPA 2010c).

Similarly, the Water Infrastructure Network (WIN) also developed a gap analysis. Their results show that the baseline expenditures of drinking water utilities need to be



increased by approximately \$300 billion over the next 20 years to maintain compliance and infrastructure needs. Likewise, wastewater utilities need to increase the baseline expenditures by around \$400 billion. Between water and wastewater utilities and including capital costs, WIN estimates that an infrastructure investment of almost \$1 trillion is needed over the next 20 years. These numbers do not mean there is a current deficit, but that significant investment is needed to meet future water infrastructure needs (AWWA 2001).

The Congressional Budget Office conducted another survey that found the annual costs for investment during 2000 to 2019 will cost on average between \$11.6 billion and \$20.1 billion for drinking water systems and between \$13.0 billion and \$20.9 billion for wastewater systems. The operation and maintenance annual costs are project to be between \$25.7 billion and \$31.8 billion for drinking water and between \$20.3 billion and \$25.2 billion for wastewater systems (Congressional Budget Office 2002).

### **2.3 Conventional Water Distribution Systems**

The conventional drinking water system is designed to deliver water of drinking water quality to individual houses and businesses. One main goal of the water distribution system is to prevent water borne diseases. Typically, this is achieved by withdrawing water from the environment, purifying it, and distributing it through a pressurized pipe system (Hammer and Hammer 2008; Harremoes 2000; Viessman and Hammer 1998).

The treatment train used for drinking water treatment is dependent on the water source. For a lake or reservoir supply, a typical water treatment train is as follows, water enters a rapid mix basin where coagulants and auxiliary chemicals are added. Then, it enters a flocculation basin followed by a settling tank. After settling, the water is filtered,

and chlorine and fluoride are added before entering the distribution system (Hammer and Hammer 2008).

In an example treatment train for river water, the water first enters a presedimentation basin. Next, the water enters a rapid mix tank where coagulants and chemicals are added. Then, the water enters a flocculation tank followed by a settling tank. After the settling tank, the water enters another rapid mix tank where additional chemicals are added. It then goes through the flocculation and settling processes again before being filtered. Finally, chlorine and fluoride are added before it enters the distribution system (Hammer and Hammer 2008).

The treatment processes for groundwater are more varied depending on what pollutants need to be removed. For iron and manganese removal, the water is aerated followed by addition of chlorine or potassium permanganate before entering a contact tank. Then the water is filtered, and chlorine and fluoride are added before entering the distribution system (Hammer and Hammer 2008; Viessman and Hammer 1998).

Groundwater is also treated to remove hardness by adding lime or soda ash in a rapid mixing tank followed by flocculation and settling. After settling, carbon dioxide is added to recarbonate the water before it is filtered. Chlorine and fluoride are added before the water enters the distribution system. Ion-exchange followed by disinfection and fluoridation is also sometimes used. In some cases, the groundwater quality is such that only disinfection and fluoridation are required (Hammer and Hammer 2008; Viessman and Hammer 1998).

The distribution network must be designed to supply water at sufficient pressure for fire flow. The piping network for the conventional system is designed to handle the peak day plus fire flow. As a result, the minimum allowable pipe diameter is 6 inches (152 mm) (Hammer and Hammer 2008; Viessman and Hammer 1998; AWWA 2008).

The distribution system is a grid pattern of water mains that distributes water for commercial, industrial, domestic, and firefighting purposes. The distribution system has elevated storage tanks, or ground-level reservoirs with pumps, which store water for peak flows and fire demand. The distribution system has fire hydrants, shutoff valves and service connections. The fire hydrants allow easy access to water during a fire. The shutoff valves allow a portion of the system to be isolated for maintenance or to isolate a main break. Service connections are used to connect each building into the water system; each service line has a shutoff valve, water meter, and pressure regulator or relief valve if necessary (Hammer and Hammer 2008; Viessman and Hammer 1998).

### **2.3.1 Potable Water Quality**

In the United States, the USEPA is charged with regulating potable water quality. Table 2.1 lists some of the United States primary drinking water regulations, and Table 2.2 lists the secondary drinking water regulations.

**Table 2.1 United States Primary Drinking Water Regulations**

<b>Contaminant</b>	<b>MCLG<sub>1</sub> (mg/L)</b>	<b>MCL or TT<sub>1</sub> (mg/L)</b>
<i>Cryptosporidium</i>	Zero	TT <sub>2</sub>
<i>Giardai lamblia</i>	Zero	TT <sub>2</sub>
<i>Legionella</i>	Zero	TT <sub>2</sub>
Total Coliforms (including fecal coliform and <i>E. Coli</i> )	Zero	TT <sub>2</sub>
Turbidity	n/a	TT <sub>2</sub>
Viruses (enteric)	Zero	TT <sub>2</sub>
Arsenic	0	0.010
Cadmium	0.005	0.005
Chromium (total)	0.1	0.1
Copper	1.3	TT <sub>3</sub> ; Action Level =1.3
Lead	Zero	TT <sub>3</sub> ; Action Level = 0.015
Mercury (inorganic)	0.002	0.002
Nitrate (measured as Nitrogen)	10	10
Nitrite (measured as Nitrogen)	1	1

<sup>1</sup> Definitions: Maximum Contaminant Level Goal (MCLG)-The level of a contaminant in drinking water below which there is no known or expected risk to health. MCLGs allow for a margin of safety and are non-enforceable public health goals. Maximum Contaminant Level (MCL)-The highest level of a contaminant that is allowed in drinking water. MCLs are set as close to MCLGs as feasible using the best available treatment technology and taking cost into consideration. MCLs are enforceable standards. Treatment Technique (TT)-A required process intended to reduce the level of a contaminant in drinking water.

<sup>2</sup> EPA's surface water treatment rules require systems using surface water or ground water under the direct influence of surface water to (1) disinfect their water, and (2) filter their water or meet criteria for avoiding filtration so that the following contaminants are controlled at the following levels:

- *Cryptosporidium*: Unfiltered systems are required to include *Cryptosporidium* in their existing watershed control provisions
- *Giardia lamblia*: 99.9% removal/inactivation
- Viruses: 99.99% removal/inactivation
- *Legionella*: No limit, but EPA believes that if *Giardia* and viruses are removed/inactivated, according to the treatment techniques in the Surface Water Treatment Rule, *Legionella* will also be controlled.
- Turbidity: For systems that use conventional or direct filtration, at no time can turbidity (cloudiness of water) go higher than 1 nephelometric turbidity unit (NTU), and samples for turbidity must be less than or equal to 0.3 NTU in at least 95 percent of the samples in any month. Systems that use filtration other than the conventional or direct filtration must follow state limits, which must include turbidity at no time exceeding 5 NTU.

<sup>3</sup> Lead and copper are regulated by a Treatment Technique that requires systems to control the corrosiveness of their water. If more than 10% of tap water samples exceed the action level, water systems must take additional steps. For copper, the action level is 1.3 mg/L, and for lead is 0.015 mg/L

From: (United States Environmental Protection Agency 2011)

**Table 2.2 United States Secondary Drinking Water Regulations**

Contaminant	Secondary Standard
Aluminum	0.05 to 0.2 mg/L
Chloride	250 mg/L
Color	15 (color units)
Copper	1.0 mg/L
Iron	0.3 mg/L
Manganese	0.05 mg/L
pH	6.5-8.5
Sulfate	250 mg/L
Total Dissolved Solids	500 mg/L
Zinc	5 mg/L

From: (United States Environmental Protection Agency 2011)

### 2.3.2 Water Demand

In 1999, the American Water Works Association Research Foundation published a comprehensive study on the residential uses of water. From the collected data, a breakdown of water demand by plumbing fixture was determined for each of 12 study cities. The average indoor demand was found to be 69.3 gpcd (262 lpcd) with a range of 57.1 gpcd (216 lpcd) in Seattle, WA to 83.5 gpcd (316 lpcd) in Eugene, OR. Figure 2.1 summarizes the breakdown of indoor demand by use.

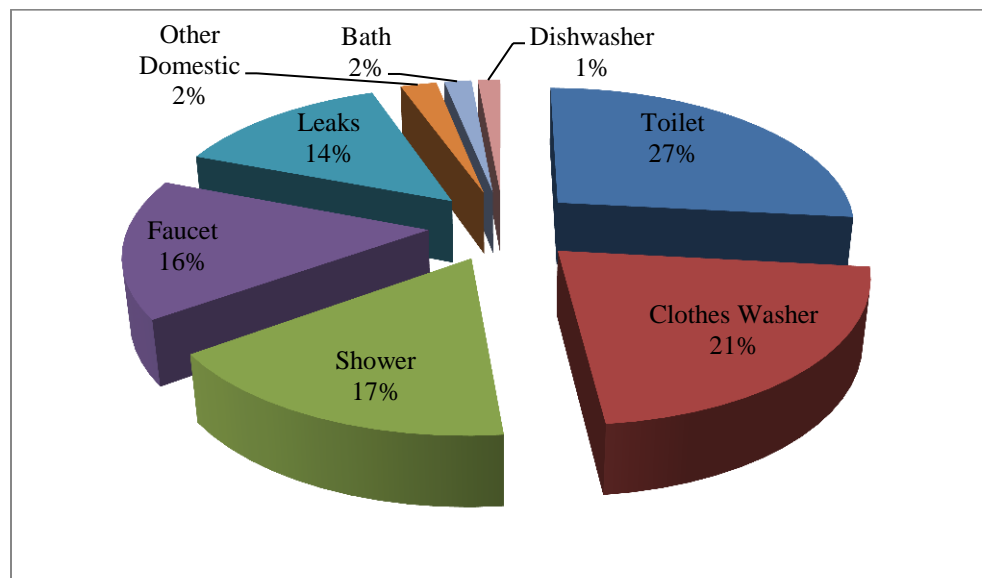

Adapted from: (Mayer et al. 1999)

**Figure 2.1 Breakdown of Indoor Residential Use by Fixture**

Currently, most cities in the United States use potable water for landscape irrigation. As a result, irrigation demand constitutes a large portion of the residential water demand. Cities in arid climates such as Phoenix and Scottsdale, AZ have an annual outdoor demand of 161.9 kgal/home (612.9 kL/home) and 156.5 kgal/home (592.4 kL/home), respectively that is more than double the annual indoor demand. Likewise, cities in a wetter climate such as Tampa, FL have an outdoor demand (30.5 kgal/home, 115.5 kL/home) that is a little over half of the annual indoor demand (56.1 kgal/home, 212.4 kL/home) (Mayer et al. 1999). Removing the irrigation demand from the potable supply network drastically reduces the potable water demand.

### **2.3.3 Wastewater Treatment**

Once water has been used, it is collected via the sanitary sewer system. The water is transported to a wastewater treatment facility where it is treated before being released back into the environment. Flows in the sewer system are typically open channel or not under pressure. The water is moved downstream in the pipe by gravity. The flow velocity is dependent on the pipe slope and frictional resistance (Hammer and Hammer 2008; Viessman and Hammer 1998).

Wastewater must be treated to the levels specified in the National Pollutant Discharge Elimination System (NPDES) permit for the facility. Conventional pollutants from wastewater facilities include suspended solids, biochemical oxygen demand (BOD), fecal coliforms, oil, greases, and pH (Hammer and Hammer 2008; Viessman and Hammer 1998). Toxic pollutants include heavy metals and synthetic organic chemicals. Nonconventional pollutants include nitrogen and phosphorous as well as any substances not considered as conventional or toxic pollutants (Hammer and Hammer 2008).

NPDES permits contain standard conditions that are the same for all permits, effluent limits that are specific to the site, compliance monitoring and reporting requirements, and site-specific parameters needed for discharge control (Hammer and Hammer 2008; Viessman and Hammer 1998). The effluent standards can be based on technology or water quality. Public owned wastewater treatment facilities must evaluate the best available technology that is economically feasible. Water-quality based effluent standards are based on the water uses assigned to the receiving water. For example, a wastewater treatment plant discharging into a stream that is used by a downstream town for potable water supply will have more stringent water quality effluent standards than a wastewater treatment plant discharging to a stream used for agricultural purposes (Hammer and Hammer 2008).

Conventional wastewater treatment includes primary and secondary treatment, disinfection, and solids treatment. During preliminary and primary treatment, the raw wastewater passes through a screen to remove large debris and then a grit removal chamber to remove smaller debris before entering the primary settling tank. Secondary treatment involves biological treatment followed by secondary settling. After secondary treatment, the water is disinfected and then discharged to the receiving waters. The solids from the primary settling tank enter the sludge digester. Some sludge from secondary settling is recycled back to the biological treatment basin while the remainder goes through a sludge thickening process before entering the sludge digester. From the digester, the solids are dewatered, with the water portion returned to the start of the plant, and the dewatered solids are sent to biosolids disposal (Hammer and Hammer 2008;

Viessman and Hammer 1998). Characteristics of typical wastewater from municipal sources before and during conventional treatment are in Table 2.3.

**Table 2.3 Typical Characteristics of Municipal Wastewater**

<b>Parameters</b>	<b>Raw (mg/l)</b>	<b>After Primary Settling (mg/l)</b>	<b>After Biological Treatment (mg/l)</b>
Total solids	800	680	530
Total volatile solids	440	340	220
Suspended solids	240	120	30
Volatile suspended solids	180	100	20
Biochemical Oxygen Demand	200	130	30
Inorganic nitrogen as N	22	22	24
Total nitrogen as N	35	30	26
Soluble phosphorous as P	4	4	4
Total phosphorous as P	7	6	5

From: (Hammer and Hammer 2008)

## 2.4 Dual Distribution Systems

Dual distribution systems include one piping system to distribute potable water and another piping system for non-potable water (Plumbing-Heating-Cooling Contractors Association 2006). Advantages of a dual distribution system include improved potable water quality because demands such as fire flow and irrigation, which dictate the size of pipe required, can be shifted to non-potable water. As a result, a smaller amount of water would need to be treated to potable standards, and a smaller diameter pipe network can be used (AWWA 2009; DiGiano et al. 2009). Similarly, smaller drinking water treatment plants would be required to treat the reduced amount of potable water (AWWA 2009). Disadvantages to dual distribution systems include the expense of two separate pipe networks. Motivation for building dual distribution systems originated with the desire to decrease the potable water demand by using reclaimed water to meet non-potable demands (DiGiano et al. 2009).



The minimum pipe diameter of a water supply system is often controlled by fire flow. As such, it is generally much greater than the diameter that is needed to meet the potable demand. The larger pipes increase the residence time in the system, leading to water quality degradation. Residual disinfection can be lost, allowing for microbial regrowth and more reactions with organic matter to create disinfection by-products (DiGiano et al. 2009).

Shifting demands such as fire flow, irrigation, and toilet flushing to a separate distribution system greatly reduces the demands on the potable system. In a study for Briar Chapel, NC, the potable demand was reduced by 48% when toilet flushing and irrigation were removed (DiGiano et al. 2009).

One issue with dual distribution systems is the possibility of cross-connections. To help prevent cross-connections, pipes carrying reclaimed water must be wrapped in purple colored tape, or the pipe itself must be purple. Any mechanical equipment used for the reclaimed water must also be painted purple. The reclaimed pipe network cannot be laid in the same trench as the potable pipes. A horizontal separation distance of 9.8 ft (3 m) must exist between the two pipe networks. If the pipe systems must cross, the potable system must cross above the reclaimed system (Asano 2007; AWWA 2009).

## **2.5 Greywater Systems**

Greywater systems are based on reusing lightly contaminated water from the house such as water from showering and hand washing. A study in Australia reported a 20.0% to 32.5% reduction in potable water use when greywater was used for lawn irrigation and toilet flushing. Likewise, wastewater totals were reduced by 33.2% to 54.1% by implementing greywater reuse (Zhang et al. 2010).

### **2.5.1 Greywater Sources**

Greywater is defined as the wastewater from all household sources except for toilets (Christova-Boal et al. 1996; Ludwig 2009). The definition is commonly restricted to include only human washing operations such as baths, showers, and bathroom sinks (Jefferson et al. 2004; Ludwig 2009). Other authors also include laundry water in the definition of greywater (Christova-Boal et al. 1996; Al-Jayyousi 2003). The greywater definition used by the National Standard Plumbing Code (2006) is “used untreated water generated by clothes washing machines, showers, bathtubs and lavatories. It shall not include water from kitchen sinks or dishwashers.”

### **2.5.2 Greywater Quality**

Several studies report that greywater must be treated as dilute sewage because it contains all of the components of raw wastewater (Christova-Boal et al. 1996). Greywater itself typically contains low levels of fecal contamination, but several studies have reported high levels of fecal indicators. In some instances, the quantity of fecal indicators was in the range associated with raw wastewater (Alkhatib et al. 2006). Other sources report greywater being relatively free of organic matter, pathogens, and trace constituents (Asano 2007).

The quality of greywater is highly dependent on the quality of the water supply, the piping network, and the activities in the home. The piping network can affect the quality of water because of leaching from the pipe, and biological and chemical processes occurring in the biofilm on the pipe walls. The most important determinations of the quality are the lifestyle, installations, and chemicals used in the household (Eriksson et al. 2002). Table 2.4 lists the characteristics of greywater from various sources.

**Table 2.4 Characteristics of Greywater**

Parameter	(Christova-Boal et al. 1996)		(Surendran et al 1998) grab samples		
	Bathroom water range <sub>1</sub>	Laundry water range <sub>1</sub>	Bath/shower <sub>1</sub>	Wash Basin <sub>1</sub>	Washing Machine <sub>1</sub>
Aluminium	<1.0	<1.0-2.1			
Ammonia, as N	<0.1-15	<0.1-1.9	1.56	0.53	10.7
Arsenic, as AS	0.001	0.001-0.007			
BOD <sub>5</sub> /d	76-200	48-290	216	252	472
Cadmium, as Cd	<0.01	<0.01	0.54	-	0.63
Calcium	3.5-7.9	3.9-12			
Chloride, as Cl	9.0-18	9.0-88			
COD			424	433	725
Copper	0.06-0.12	<0.05-0.27	111	-	322
Dissolved solids			559	520	590
EC 25°C, µS/cm	82-250	190-1400			
Fecal coliforms/100 mL	MPN 170-3.3E3	MPN 110-1.09E3	600 cfu	32 cfu	728 cfu
Fecal streptococci/100mL	MPN 79-2.4E3	MPN 23-2.4E3			
Inorganic carbon			26	20	25
Iron	0.34-1.1	0.29-1.0			
Lead			3	-	33
Magnesium	1.4-2.3	1.1-2.9			
Nitrate and nitrite as N	<0.05-0.20	0.10-0.31	0.9	0.34	1.6
Oil and grease	37-78	8.0-35			
pH	6.4-8.1	9.3-10	7.6	8.1	8.1
Phosphate as P			1.63	45.5	101
Phosphorus, total as P	0.11-1.8	0.062-42			
Potassium	1.5-5.2	1.1-17			
Silicon	3.2-4.12	3.8-49			
Sodium	7.4-1.8	49-480			
Sulfur	1.2-3.3	9.5-40			
Suspended solids	48-120	88-250	76	40	68
Total alkalinity, as CaCO <sub>3</sub>	24-43	83-200			
Total coliforms/100 mL	MPN 500-2.4E7	MPN 2.3E3-3.3E5	6E6 cfu	5E4 cfu	7E5 cfu
Total Kjeldahl nitrogen, as N	4.6-20	1.0-40			
Total organic carbon			104	40	110
Total solids			631	558	658
Turbidity,NTU	60-240	50-210	92	102	108
Volatile solids			318	240	330
Zinc	0.2-6.3	0.09-0.32	59	-	308

<sub>1</sub> Units in mg/L unless otherwise noted.

### 2.5.3 Greywater Treatment

Untreated greywater contains soaps, detergents, dirt from laundry, and organic matter and pathogens from human bodies (Novotny et al. 2010). When compared to toilet

wastewater, greywater has fewer pathogens and 90% less nitrogen. Greywater treatment is less expensive and requires less energy than wastewater treatment because of lower solids loading rates, BOD loading, and lower microbial content (Sheikh 2010; Ishida et al. 2009). As a result, greywater treatment is cheaper and less complex than standard wastewater treatment (Asano 2007; Zhang et al. 2010). Common greywater treatment systems include modified sand filters, constructed wetlands, biological systems such as membrane bioreactors (MBR), and biologically aerated filters (Zhang et al. 2010). The current regulations for greywater are not dependent on health risk data such as pathogen dose-response, but are instead based on the perceived risk (Ishida et al. 2009).

#### 2.5.4 Greywater Quantities

Approximately, 50-80% of household wastewater is greywater (Novotny et al. 2010; Eriksson et al. 2003). Limiting the definition of greywater to include water from showers, baths, laundry, and bathroom sinks, the amount of greywater produced can be determined from the data presented in Table 2.5.

**Table 2.5 National Average of Greywater Production Broken Down by Fixture.**

Fixture	Amount	
	gpcd	lcpd
Toilet	6.57	24.87
Shower	16.40	62.08
Clothes washer	5.49	20.78
Faucet	10.85	41.07
Total greywater production	39.31	148.80

Source: (Mayer et al. 1999).

Note: Faucet amount includes both kitchen and bathroom faucets.

A breakdown of greywater production in the United States is shown in Figure 2.2. The faucet use is overestimated in Table 2.5 and Figure 2.2 as it includes both the kitchen

and bathroom sinks. The average greywater production from the bathroom sink is 3 gpd (11.4 lpd) as discussed later in Section 3.1.

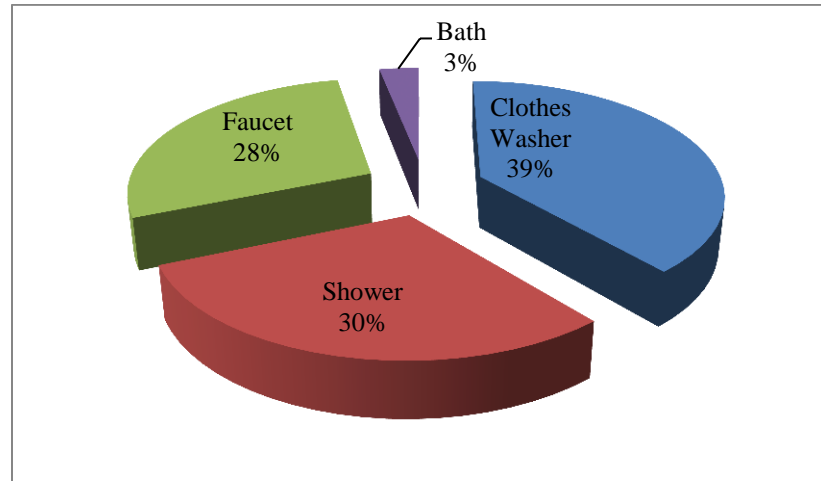

Adapted from: (Mayer et al. 1999)

**Figure 2.2 Breakdown of Greywater Production in the United States.**  
The value for the faucet includes both the kitchen and bathroom faucets.

### 2.5.5 Greywater Uses

Many uses exist for greywater, but they are heavily dependent on the quality of greywater and the amount of treatment it has received. Essentially, greywater can be used for any purpose as long as it is treated to meet the appropriate standards (Li et al. 2009). Two common uses for greywater are toilet flushing and garden watering (Christova-Boal et al. 1996). Other uses are laundry, window, and vehicle washing, fire protection, boiler feed water, and concrete production (Eriksson et al. 2003). Untreated greywater can be used for subsurface irrigation (Zhang et al. 2010; Christova-Boal et al. 1996; Ludwig 2009).

### 2.5.6 Health Concerns Associated with Greywater Use

The impact of greywater on human health depends on the pathogen source and the exposure routes (Ottoson and Stenstrom 2003). Health concerns associated with greywater reuse include the possibility of spreading diseases because of microorganisms

in the water. Possible transmission pathways include direct contact with greywater, and irrigation (Ottoson and Stenstrom 2003). For example, if the water is used for toilet flushing, it is possible that contaminants in the water can become aerosols (Ludwig 2009; Eriksson et al. 2002).

Most of the health concerns associated with greywater can be avoided by using proper precautions. The first is to design the greywater system so no human-to-greywater contact occurs. The greywater should also percolate through topsoil for natural purification to occur. Washing hands after contact with greywater or wearing gloves when cleaning greywater filters helps to protect from ingesting any microorganisms that might be present. Likewise, untreated greywater should not be applied directly to lawns, or vegetables and fruits that are eaten raw (Ludwig 2009). No cases of greywater-transmitted illness have been documented in the United States, and taking precautions such as the ones listed above will help to avoid any potential illnesses occurring from greywater (Ludwig 2009; Sheikh 2010).

## **2.6 Rainwater Systems**

Rainwater harvesting is not a new concept. It has been utilized in dry climates for thousands of years. Rainwater is a free water source with only treatment and storage costs. Harvesting of rainwater augments groundwater supplies by reducing the quantity of water withdrawn, and reduces stormwater runoff. In urban areas, rainwater harvesting reduces non-point pollution and erosion. Water collected from rainwater harvesting can be used for non-potable indoor uses. With proper treatment, the water can also be used for potable purposes. Rainwater harvesting is also generally more economical than expanding the public water supply (Aladenola and Adeboye 2010; Texas Water

Development Board 2005). Combining widespread rainwater harvesting with other technologies has the potential to reduce greenhouse gas emissions by reducing the size of water storage reservoirs and reducing the quantity of water that needs to be treated (Aladenola and Adeboye 2010).

### **2.6.1 Collection of Rainwater**

Rainwater can be harvested from any surface. The most common system is roof-based collection. The amount of water that can be collected is dependent on the area of the roof, amount of rainfall, and storage capacity (Aladenola and Adeboye 2010; Texas Water Development Board 2005). Rainwater from residential roofs is considered safe for most residential uses (Zhang et al. 2010). Specific uses are listed in Section 2.6.4. An Australian study reported a savings of 12.3% to 25.1% in potable water use when harvested rainwater was used for toilet flushing and lawn irrigation. Residential use of rainwater in this study decreased the stormwater runoff by 23.4% to 48.1% (Zhang et al. 2010).

### **2.6.2 Rainwater Quality**

The quality of rainwater is impacted by the age and cleanliness of the catchments, gutters, pipes, and storage tanks as well as the atmospheric conditions. Maintenance of the rainwater harvesting system before storms greatly improves the water quality (Lee et al. 2010). A summary of typical rainwater quality parameters is listed in Table 2.6.

**Table 2.6 Rainwater Quality**

Parameter	(Appan 1999)	(Lee et al. 2010)	
	Rainwater <sub>1</sub>	Harvested Rainwater <sub>2</sub>	Rainwater <sub>2</sub>
pH	4.1 (0.4)	7.3 (6.7-7.8)	5.3 (4.3-6)
Colour	8.7 (9.9)		
Turbidity (NTU)	4.6 (5.7)		
TSS (mg/L)	9.1 (8.9)		
TDS (mg/L)	19.5 (12.5)	88 (40-230)	7.6 (3.4-52.1)
Hardness as CaCO <sub>3</sub> (mg/L)	0.1 (0.3)		
PO <sub>4</sub> as P (mg/L)	0.1 (0.6)		
Total coliform (MPN/100mL)	92.0 (97.1)	70 CFU/100 mL	ND <sub>3</sub>
Faecal coliform (MPN/100mL)	6.7 (8.9)		
Conductivity (µS/cm)		170 (50-340)	30 (50-340)
Nitrate (mg/L)		6.8 (2.9-9.8)	2.2 (0.6-4.2)
NH <sub>4</sub> <sup>+</sup> (mg/L)		0.09 (0.06-0.39)	0.02 (0.0-0.05)
Phosphate		0.02 (0-0.04)	ND
Chloride (mg/L)		7.5 (5-18)	3.0 (1.1-10)
Calcium (mg/L)		6.4 (3.24-15.4)	1.6 (0.17-3.82)
Magnesium (mg/L)		1.2 (0.5-2.7)	0.22 (0.04-0.62)
Sodium (mg/L)		3.2 (2.2-6.1)	1.1 (0.24-4)
Potassium (mg/L)		3.1 (1.3-5.9)	2.1 (0.16-6.5)
Sulfates (mg/L)		4.1 (2-7.2)	2.4 (1-6.2)
Mn (µg/L)		115 (70-170)	40 (20-80)
Pb (µg/L)		27 (10-40)	20 (10-40)
Cu (µg/L)		85 (70-120)	35 (20-80)
Cr (µg/L)		4.5 (0-10)	1 (0-5)
Cd (µg/L)		1.5 (0-4)	ND
As (µg/L)		3 (0-6)	ND
Zn (µg/L)		160 (120-280)	60 (40-90)
Al (µg/L)		225 (100-400)	100 (50-240)
E. coli (CFU/100mL)		10 (0-60)	ND

<sub>1</sub> Values are means, values in parentheses are standard deviations

<sub>2</sub> Values are medians, values in parentheses are ranges

<sub>3</sub> No detection

Treatment for rainwater is dependent on local guidelines. The City and County of San Francisco, CA allows for toilet flushing with untreated rainwater. In Portland, OR, rainwater must be filtered before using for non-potable indoor uses. Texas requires both



filtration and disinfection before the water can be used indoors for non-potable demands. Germany showed that the risk of human mouth contact with *E. coli* from toilet flushing was almost non-existent. As a result, it was recommended that disinfection is unnecessary for rainwater used for non-potable purposes (Kloss 2008). The minimum treatment guidelines and treatment options for stormwater reuse are given in Table 2.7.

**Table 2.7 Minimum Water Quality Guidelines and Treatment Options for Stormwater Reuse**

Use	Minimum Water Quality Guidelines	Suggested Treatment Options
Potable indoor uses	<ul style="list-style-type: none"> <li>• Total coliforms – 0</li> <li>• Fecal coliforms – 0</li> <li>• Protozoan cysts – 0</li> <li>• Viruses – 0</li> <li>• Turbidity &lt; 1 NTU</li> </ul>	<ul style="list-style-type: none"> <li>• Pre-filtration – first flush diverter</li> <li>• Cartridge filtration – 3 micron sediment filter followed by 3 micron activated carbon filter</li> <li>• Disinfection – chlorine residual of 0.2 ppm or UV disinfection</li> </ul>
Non-potable indoor uses	<ul style="list-style-type: none"> <li>• Total coliforms &lt; 500 cfu per 100 mL</li> <li>• Fecal coliforms &lt; 100 cfu per 100 mL</li> </ul>	<ul style="list-style-type: none"> <li>• Pre-filtration – first flush diverter</li> <li>• Cartridge filtration – 5 micron sediment filter</li> <li>• Disinfection – chlorination with household bleach or UV disinfection</li> </ul>
Outdoor uses	N/A	<ul style="list-style-type: none"> <li>• Pre-filtration – first flush diverter</li> </ul>

\*cfu – colony forming units

\*NTU – nephelometric turbidity units

From: (Kloss 2008)

### 2.6.3 Rainwater Quantities

Rainwater is typically collected from the roof of a building (Novotny et al. 2010).

The quantity of rainwater collected depends on the size of the roof, the capture efficiency, and the amount of rainfall a region receives. A rule of thumb number for rainwater

harvesting is that a rainfall of 1 inch (25.4 mm) on a 1000 square foot (92.9 square meters) house results in 600 gallons (2271 liters) of water being collected (Kloss 2008).

#### **2.6.4 Rainwater Use**

Research has established that water collected from roofs is of acceptable quality to be used for toilet flushing, and outdoor uses (Coombes and Barry 2007). Potable use from rainwater is possible but on-site treatment is needed. Rainwater is best used for non-potable purposes such as irrigation, toilet flushing, and HVAC make-up water (Texas Water Development Board 2005; Kloss 2008).

#### **2.6.5 Health Concerns Associated with Rainwater Use**

The health concerns associated with rainwater risk are quite low as long as proper treatment methods are used. The use of filter systems before rainwater enters the cistern helps to eliminate debris and dust from entering the cistern and is suitable for non-potable use. If the harvested rainwater is used for potable water, the water must be treated to eliminate sediment and disease-causing pathogens. Typical treatment consists of filtration and disinfection (Texas Water Development Board 2005) .

### **2.7 Reclaimed Water**

According to the National Standard Plumbing Code (2006), the definition of reclaimed water is “effluent from a wastewater treatment facility that has been subjected to extensive treatment in order to remove organic material, heavy metals, and harmful pathogens (such as bacteria, viruses, and protozoa). Reclaimed water is non-potable.” The use of reclaimed water is an innovative alternative water source for industry, agriculture, and municipalities. Utilizing the treated wastewater to augment the current water supply is becoming more economical because of the high treatment standards. This is especially true when comparing the cost of using reclaimed water to developing new

water resources, which is both expensive and environmentally destructive (Lu and Leung 2003).

Reclaimed water can also be used for potable purposes. Indirect potable use occurs when the reclaimed water is discharged to a water supply source (e.g. groundwater aquifer or water supply reservoir). Direct potable use occurs when the reclaimed water directly enters the water distribution network. Indirect potable use is more widely accepted than direct potable use. (Asano 2007; Novotny et al. 2010; Daigger 2009).

Implementation of reclaimed water use is becoming more widespread in areas where evapotranspiration is high, rainfall is low, and irrigation water use is intense. The growing population in the arid southwest portion of the United States is increasing the strain on the current water supply. Therefore, water reuse is being used as a way to ease this strain. Other benefits include preservation of high-quality water for potable use, improved quality of surface water, and additional recreational opportunities (Viessman and Hammer 1998; Okun 1997).

### **2.7.1 Reclaimed Water Quality**

Water can be treated to nearly any level of purity with the water treatment technologies currently available. However, there will always be some residual contaminants in the water (Harremoes 2000). The quality of reclaimed water depends on its intended use. Water that is to be used in places with unrestricted public access must be treated to the highest levels (USEPA 2004).

After undergoing secondary treatment, the common pollutants that typically need to be removed from municipal wastewater include, nitrates, phosphates, microorganisms,

total dissolved solids, and refractory organics like trace levels of pesticides. However, if the reclaimed water is to only be used for irrigation, it may be advantageous to leave the nitrates and phosphates in the water to act as nutrients for the vegetation. Therefore, the end use of the water must be determined before the required level of treatment required (Viessman and Hammer 1998).

High-quality effluent for reuse in reclaimed systems often requires advanced or tertiary treatment (Viessman and Hammer 1998). Treatment for reclaimed water can include microfiltration, or ultrafiltration, followed by reverse osmosis, an advanced oxidation process, and disinfection. After this treatment, there are no pathogens and most trace constituents will be below detection levels (Asano 2007). The treatment levels required for various uses can be found in *Guidelines for Water Reuse* (USEPA 2004). The treatment requirements for unrestricted urban reuse in seven states are listed in Table 2.8. The term oxidized is used to describe wastewater that is treated to stabilize and oxidize organic compounds (Asano 2007).

**Table 2.8 State Guidelines for Unrestricted Reclaimed Water Use**

Parameter	Arizona	California	Florida	Hawaii	Nevada	Texas	Washington
Treatment	Secondary treatment, filtration and disinfection	Oxidized coagulated, filtered, and disinfected	Secondary treatment, filtration, and high-level disinfection	Oxidized, filtered, and disinfected	Secondary treatment and disinfection	NS*	Oxidized, coagulated, filtered, and disinfected
BOD <sub>5</sub>	NS	NS	20 mg/l CBOD <sub>5</sub>	NS	30 mg/l	5 mg/l	30 mg/l
TSS	NS	NS	5.0 mg/l	NS	NS	NS	30 mg/l
Turbidity	2 NTU (Avg)	2 NTU (Avg)	NS	2 NTU (Max)	NS	3 NTU	2 NTU (Avg)
	5 NTU (Max)	5 NTU (Max)					5 NTU (Max)
Coliform	Fecal	Total	Fecal	Fecal	Fecal	Fecal	Total
	Non detectable (Avg)	2.2/100 ml (Avg)	75% of samples below detection	2.2/100 ml (Avg)	2.2/100 ml (Avg)	20/100 ml (Avg)	2.2/100 ml (Avg)
	23/100 ml (Max)	23/100 ml (Max in 30 days)	25/100 ml (Max)	23/100 ml (Max in 30 days)	23/100 ml (Max)	75/100 ml (Max)	23/100 ml (Max)

\*NS- Not specified by state regulations

From: (USEPA 2004)

### 2.7.2 Reclaimed Water Quantities

In 1996, California had a wastewater reclamation capacity of 114 billion gallons ( $432 \times 10^6 \text{ m}^3$ ) per year. Approximately 60% of the water was used for agriculture while an additional 16% was used for landscape irrigation. Groundwater recharge accounted for 14% of total reclaimed water use (Lu and Leung 2003). At the end of 2001, California's reclaimed water use had grown to over 171 billion gallons ( $648 \times 10^6 \text{ m}^3$ ) per year. In 2004, Florida had a reclaimed water reuse quantity of 220 billion ( $834 \times 10^6 \text{ m}^3$ ) per year. Approximately 45% was used for landscape irrigation, and around 15% each was used for agricultural irrigation, industrial use, and groundwater recharge (Asano 2007). The quantity of reclaimed water depends on the demand and capacity of the wastewater treatment plants producing the reclaimed water and the amount of wastewater generated (AWWA 2009).

### **2.7.3 Reclaimed Water Uses**

Reclaimed water can be used for any purpose as long as it meets the treatment requirements for the use. Common uses are both landscape and agricultural irrigation. Other reuse options include industrial reuse such as cooling water, process water, and boiler feed water. In some regions, reclaimed water is used for groundwater recharge to replenish depleted aquifers and to prevent salt water intrusion. Reclaimed water can also be used for recreational purposes such as filling lakes and ponds, enhancing marshes, augmenting streamflow and snowmaking. Non-potable urban uses for reclaimed water include fire flow, air conditioning, and toilet flushing. Reclaimed water can also be treated to potable water standards and be blended into the water supply system (Asano 2007; AWWA 2009; Lu and Leung 2003).

### **2.7.4 Concerns Associated with Reclaimed Water Use**

The main health concerns are associated with the possible presence of pathogens such as enteric bacteria, protozoa, helminths and viruses, in the water (Asano 2007; Lu and Leung 2003). Specific pathogens of concern are fecal coliforms, *E. coli*, *Salmonella*, *Giardia*, and *Cyptosporidium* (Novotny et al. 2010). Using reclaimed water for cooling water or for fire demand can lead to the aerosol transmission of pathogens if they are present in the water (Lu and Leung 2003). As a result, the reuse of reclaimed water could lead to an increased risk of waterborne disease (Asano 2007; Fane et al. 2002). However, as of 2007, there was no epidemiological evidence showing that reclaimed water had caused any disease outbreaks in the United States (Asano 2007).

Another concern is trace organics in the water and their associated long-term health effects (Asano 2007; Lu and Leung 2003). Asano (2007) points out that it is impossible to be certain that direct potable use is 100% safe; however, it is important to

realize that an equal risk exists with traditional potable water supplies. The health risks associated with direct potable reuse are similar to drinking water facilities whose water source is influenced by wastewater effluent from other cities upstream (Asano 2007).

Other concerns associated with reclaimed water use include the effect of water quality on soils and crops. Reclaimed water can also contain constituents that cause corrosion, scaling, biological growth, and fouling within the distribution system. In addition, there is the concern of cross contamination with the potable water system (Lu and Leung 2003).

## **2.8 Decentralized Water and Wastewater Treatment Plants**

With the aging and need for expansion of current water infrastructure, decentralized water systems are being used to augment centralized water services (Moglia et al. 2010). Decentralized systems are ones in which the collection, treatment, and reuse of treated wastewater occurs at or close to the point of generation (Asano 2007). Similarly, switching from centralized treatment systems to decentralized treatment eliminates the need to build treatment plants that can meet the long-term capacity for a community; instead, decentralized plants can be built to meet the imminent demands. Decentralized treatment also reduces the size of distribution and collection systems yielding large decreases in capital costs. Switching to smaller treatment plants also minimizes the risk associated with treatment because it affects fewer people and a smaller area (Venhuizen 2008). Decentralized systems have a smaller environmental impact than conventional systems and are less resource intensive (Fane et al. 2002).

One study, in which the authors accounted for the economic value of waterborne infections into the life cycle cost per household, found that the optimum number of

connections for urban recycling and irrigation is 1,000. Before the cost of infections was included, this number was between 2,400 and 24,000 connections. The authors found that smaller systems posed a lower risk of waterborne illness when all other parameters were equal (Fane et al. 2002).

### **2.8.1 Advantages of Decentralized Treatment**

Advantages of decentralized systems include reduced risk of failure, reduced cost and resource use, improved service security as well as protecting and rehabilitating the natural environment (Moglia et al. 2010). Economy of scale for capital costs and operating costs occur for centralized wastewater treatment. However, diseconomy of scale occurs in the pipe network for centralized systems. As the size of the network increases, the size and diameter of pipe required to serve the network also increase thus increasing the cost of the pipe network. At some point, an optimum relationship between treatment plant costs and pipe network costs exists. This optimum represents where decentralized wastewater treatment may be advantageous (Asano 2007; Fane et al. 2002). An additional advantage to decentralized wastewater treatment is the ability to use customized treatment processes. The treatment train can be designed to treat the specific wastewater received because it is more homogeneous than water treated at centralized treatment plants which may be from industrial, commercial, and residential sources (Asano 2007; Okun 1997).

Reliability issues are also less severe with decentralized treatment. Since the plant serves a smaller area, fewer people are inconvenienced if a disruption occurs at the plant. A disruption at a central wastewater treatment plant can also lead to partially or untreated wastewater being discharged. In decentralized plants, the final use of the treated



wastewater is soil dispersal or irrigation. As a result, a disruption at the plant is unlikely to lead to a direct release to surface water (Asano 2007; Venhuizen 2008).

As mentioned previously, the implementation of decentralized wastewater treatment allows for the use of smaller pipe diameters. Reducing the pipe diameter expands the types of piping material available for the collection system. Piping material such as polyvinyl chloride (PVC) and medium density polyethylene (MPE) can be used. The plastic piping material is more flexible and easier to install than the large rigid pipes used for centralized systems. The rigid pipes in centralized system can lead to infiltration and exfiltration issues as they pass through various soil types and degrade over time. Identifying and repairing damaged pipes is also very expensive, especially when they are located under roads in urban areas. Plastic piping is less likely to leak, and it is easy to install in narrow trenches or using directional drilling. These installation techniques limit the disturbance to nearby roads and property (Asano 2007; AWWA 2009).

### **2.8.2 Disadvantages of Decentralized Water Treatment**

The primary disadvantages of decentralized systems compared to conventional systems are the lack of practice and expertise. Conventional systems have been used for more than a century resulting in established protocols and guidelines. Currently, the understanding relating to the management and operation of decentralized systems requirements is limited. Knowledge of the long-term performance such as long-term reliability, operation and maintenance costs, and any interactions with centralized systems are not available because decentralized treatment is relatively untried in cities when compared centralized treatment (Moglia et al. 2010).

In decentralized wastewater systems, the treated wastewater becomes reclaimed water and is used for purposes within the community. Reclaimed water may contain trace levels of pathogens that can infect individuals and possibly lead to an increase in waterborne diseases. However, when the cost of infections was included in an economic analysis for decentralized treatment, the general conclusion was that decentralized urban reuse systems for wastewater would be more economic than larger and centralized wastewater reuse, all other things being equal (Fane et al. 2002).

### **2.8.3 Decentralized Treatment Technologies**

The level of treatment and the treatment technologies employed in decentralized wastewater facilities is dependent on the use of the effluent. If the effluent is used for subsurface irrigation, primary treatment may be sufficient. Secondary treatment such as packed bed filters, sequencing batch reactors, rotating biological contactors, membrane bioreactors, and constructed wetlands are sufficient to prepare water for some types of direct reuse, tertiary treatment, or disinfection. Long solids retention times are utilized to decrease the sludge production (Asano 2007; Novotny et al. 2010).

Nutrient discharge standards are in place for decentralized treatment to limit the chance for nitrate groundwater contamination and surface water eutrophication. Meeting the nutrient standards for nitrogen and phosphorous can be challenging in on-site treatment. However, small cluster systems and other larger systems have the process control and chemicals needed to ensure proper nutrient removal occurs. Processes such as sodium hypochlorite, ozone, ultraviolet light, and biological filtration are some of the processes that can be used for disinfection (Asano 2007).

### 3 Methods

In this project, multiple water reuse scenarios are analyzed. The systems modeled fit into three main categories: residential homes, apartments, and a small community or neighborhood. In each instance, EPANET 2, a hydraulic computer model, is utilized to model the system and to give feedback as to the hydraulic feasibility and infrastructure requirements of the system.

#### 3.1 Water Demand and Fixture Utilization

The goal of this research is to find alternatives to conventional water systems and to promote the sustainable use of water in urban areas. Since 1999, when the *Residential End Uses of Water* (Mayer et al. 1999) was published, Leadership in Energy and Environmental Design (LEED) and Energy Star standards are frequently used in the design of buildings to reduce their impact on the environment. As a result, the flow rates presented in Table 2.5 have been modified to reflect this trend occurring in new developments. Updated water demands were developed to reflect the move toward water conservation and efficiency. The demands were calculated using the LEED and Energy Star standards for fixture flow rate and the utilization rate of each plumbing fixture reported in Mayer (1999).

The faucet use reported in Mayer (1999) includes both kitchen faucet and bathroom faucet use. Therefore, this number must be adjusted to reflect only the bathroom faucet use. Ludwig (2009) reports values of 1-5 gpcd (3.79-18.9 lpcd) for the bathroom sink and 5-15 gpcd (18.9-56.78 lpcd) for the kitchen sink. Selecting an average of 3 gpcd (11.36 lpcd) for the bathroom sink and 8 gpcd for the kitchen sink, the bathroom sink is approximately 3/11 of total sink use. Therefore, the minutes of faucet

use reported in Mayer (1999) is multiplied by 3/11 to obtain the usage time for only the bathroom sink. Table 3.1 gives the fixture utilization values for residential plumbing fixtures according to the results of Mayer's study.

**Table 3.1 Residential Fixture Utilization Values Per Capita Per Day**

Study Site	Toilet Flushes	Shower & Bath Minutes	Clothes Washer Loads	Bathroom Faucet Minutes	Dishwasher Cycles
Seattle	4.49	7.9	0.3	1.88	0.10
Tampa	4.85	8.2	0.36	2.56	0.06
Scottsdale	5.12	7.9	0.36	2.35	0.08
12 Study Site Average	5.05	8.2	0.37	2.21	0.10

Adapted from: (Mayer et al. 1999)

As mentioned previously, flow rates from LEED and Energy Star standards are used to reflect the use of water saving fixtures being implemented in new developments.

Table 3.2 summarizes the flow rates that will be used in the following analyses.

**Table 3.2 Comparison of Conventional and High Efficiency Flow Rates.**

The conventional values are as reported in *Residential End Uses of Water* (Mayer et al. 1999) and the updated values are from LEED and Energy Star Standards.

Fixture	Conventional Rates		High Efficiency Rates		References for High Efficiency Rates
	gal	l	gal	l	
<b>Toilet</b> (per flush)	3.48	13.17	1.3	4.92	(USGBC 2008)
<b>Shower and Bath</b> (per minute)	2.22	8.40	2.0	7.57	(USGBC 2008)
<b>Clothes Washer</b> (per load)	40.9	154.82	14.85	56.21	(USGBC 2008; California Energy Commission 2010)
<b>Faucet</b> (per minute)	1.34	5.07	1.34	5.07	(Mayer et al. 1999)
<b>Dishwasher</b> (per load)	10	37.85	5.8	21.96	(USEPA and U.S. Department of Energy )

### 3.2 Hydraulic Model

EPANET 2 is a program developed by the USEPA to evaluate the hydraulics and the water quality of a pressurized pipe system. The components of the program include pipes, nodes, valves, pumps, reservoirs, and storage tanks. EPANET 2 is a Windows based program (USEPA 2010a).

EPANET 2 models the pipe flows, node pressures, tank water heights, and concentrations of chemicals in the entire system. After running a system analysis, the results can be viewed on color-coded network maps, contour plots, time series graphs, and data tables (USEPA 2010a).

The hydraulic capabilities of EPANET 2 include modeling any size distribution system. Three different options for head loss calculations, the Chezy-Manning, Darcy-Weisbach, or Hazen-Williams equations, can be used to evaluate the friction losses in the system. Variable speed or constant speed pumps can be evaluated as well as the associated pumping cost and energy. Six different valve types are available to regulate parameters such as pressure and flow. In addition, different demands and demand patterns can be applied for each node. Finally, system operation is based on simple controls such as time or tank levels, or on rule-based controls, which are more complex. Simple controls change the status of a link based on a predetermined condition. Rule-based controls allow the status of a link to be based on a combination of conditions (USEPA 2010a).

EPANET 2's water quality analysis includes modeling the transportation of a non-reactive tracer in the piping system and also the transportation and fate of a reactive or decaying product. The water age in the system can also be traced. The reactions that

occur in the system are modeled in both the bulk flow and at the pipe wall. The reactions that occur in the system can also be bound by a user-specified limiting concentration. Global reaction rate coefficients can be utilized for the entire system, or local coefficients can be used for individual pipes. EPANET 2 also allows for mass chemical inputs or time-varying concentrations to be used at any point in the system. Finally, storage tanks can be modeled as plug flow, two-compartment, or complete mix reactors (USEPA 2010a).

### **3.2.1 EPANET 2 Model Validation**

EPANET was validated by inputting a simple network with four loops into EPANET and a separate hydraulic model. In this case, KYPipe was used. Running the same model in both programs yielded the same results. To further confirm the results, the network was analyzed by hand using the Hardy-Cross method. Once again the same results were obtained. Once the models were developed, a Hazen-Williams nomogram was used to ensure the correct pipe diameter was selected for the given flow, hydraulic gradient, and roughness conditions.

### **3.2.2 Sensitivity Analysis of Hazen-Williams Equation**

The Hazen-Williams equation is used to calculate head-loss in EPANET. One form of the equation presented by Hammer and Hammer (2008) is below.

$$Q = 0.281 CD^{2.63}S^{0.54}$$

Q = quantity of flow, gallons per minute  
 C = Hazen-Williams roughness coefficient  
 D = diameter of pipe, inches  
 S = hydraulic gradient, feet per foot

In this analysis, the parameter of interest is the pipe diameter. If the demand at a node increases, the required flow rate,  $Q$ , in the neighboring pipes also increases. Depending on the increase in the flow rate, the required pipe diameter may also increase. Likewise, a decrease in flow rate, requires a smaller pipe diameter.

If the roughness coefficient decreases in a pipe network the required diameter to deliver the same flow rate may increase. Similar a larger  $C$  value corresponds to smoother pipes which can decrease the required pipe diameter for a given flow rate.

A larger hydraulic gradient decreases the required pipe diameter when all other parameters are held constant. Likewise, a smaller hydraulic gradient requires a larger pipe diameter.

### **3.3 Modeling Individual Residence Reuse Systems**

The first scenarios are based on a residential house. Three different scenarios are modeled on the household level, they include:

- Simple Greywater Reuse, where untreated greywater is used for subsurface irrigation
- Complex Greywater Treatment and Reuse, where greywater is treated and used for non-potable indoor uses such as toilet flushing and clothes washing
- Rainwater Harvesting and Simple Greywater Reuse, where rainwater is stored and used for indoor non-potable uses and untreated greywater is used for subsurface irrigation

### 3.3.1 Definition of a Typical Residence

The first step in analyzing the water use and plumbing requirements in a house is determining what constitutes a typical house in the United States. The sizes and styles of houses vary greatly across the United States making it difficult to select a single house that is representative of all regions. For this study, the typical house is defined as a two-story house (basement, main floor, and second floor) with 1,277 square feet (118.64 square meters) on each floor. The house has five bedrooms and three bathrooms. The basement is assumed to be unfinished. The floor plans for the top two levels are shown below in Figure 3.1.

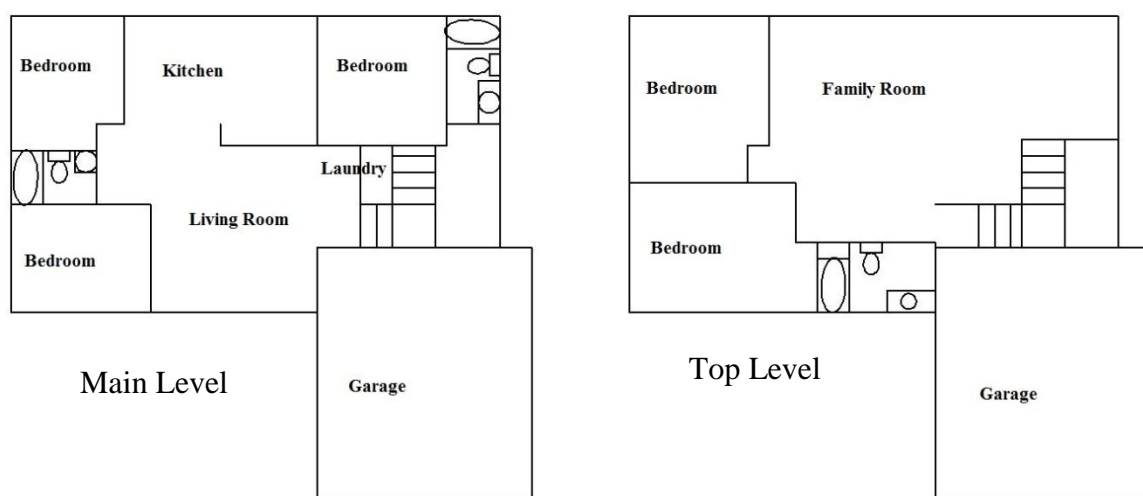

**Figure 3.1 Floor Plans for Typical Single-Family Home.**

The typical household size used in the analyses is 2.8 occupants (Mayer et al. 1999). Table 3.3 outlines the daily demand for each plumbing fixture and the daily potable and non-potable demands. The values were determined by multiplying the fixture utilization rates reported in Table 3.1 and the flow rates listed in Table 3.2. The values are based on national averages.

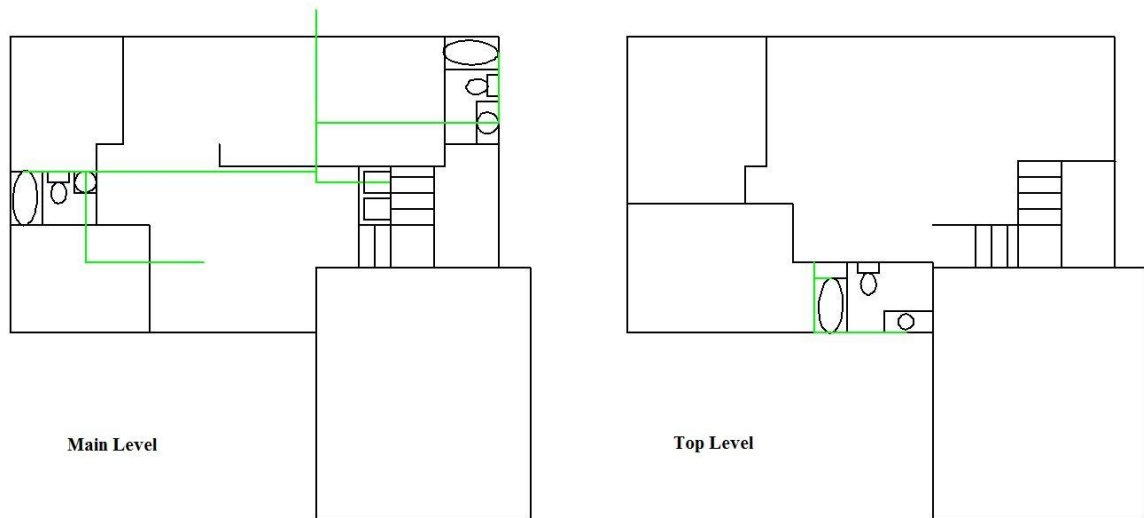

**Table 3.3 National Average Residential Per Capita Demand.**

Fixture and Overall Demands	Demand	
	gpd	lpd
Toilet	18.4	69.95
Shower	33.2	125.68
Clothes washer	15.4	58.30
Dishwasher	1.6	6.06
Kitchen Faucet	22.1	83.66
Bathroom Faucet	8.3	31.41
Potable Water Demand	65.2	246.81
Non-potable Water Demand	33.8	127.95
Greywater Produced	56.9	215.39
Wastewater Produced	42.1	159.37

### 3.3.2 Greywater Reuse System with Simple Greywater Collection and No Treatment

The first residential system analyzed involves the collection and use of greywater with no treatment. Used water from the shower/bath, bathroom sinks, and laundry is collected in the greywater plumbing system. The indoor plumbing for the simple greywater reuse system is shown in Figure 3.2.



**Figure 3.2 Indoor Greywater Plumbing for the Simple Greywater Reuse System**  
The greywater is collected from the showers, bathroom sinks, and laundry machine and then used outside for subsurface irrigation.

The greywater is piped to the backyard where it enters a tipper box. Once the tipper box is full, the water is released through subsurface pipes to provide subsurface irrigation to trees. Figure 3.3 through Figure 3.5 show the layout of the yard with the subsurface irrigation system for each study city. Note the irrigated area is not the same for each region. The irrigation area is determined by matching the available greywater to the evapotranspiration demand.

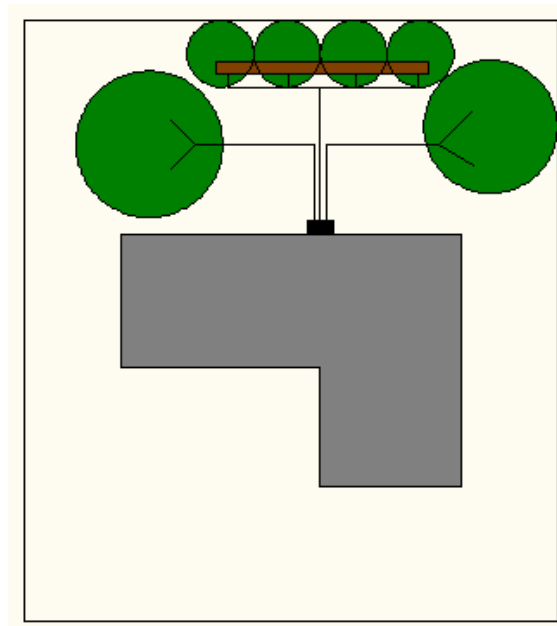

Note: The grey area is the house. The black box attached to the house is the tipper box, the brown box under the small trees is a mulch basin. Each black line represents 2" (50.8 mm) PVC pipe.

From: (Gardels 2011)

**Figure 3.3 Outdoor Subsurface Irrigation Layout for Houses in Tampa and Seattle.**

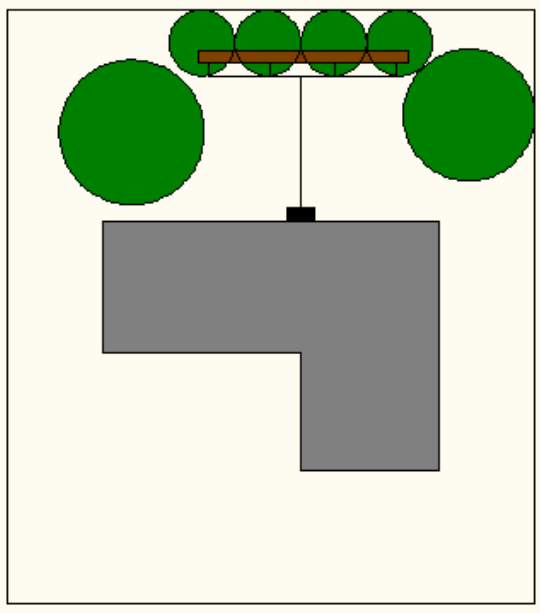

Note: The grey area is the house. The black box attached to the house is the tipper box, the brown box under the small trees is a mulch basin. Each black line represents 2" (50.8 mm) PVC pipe.  
From: (Gardels 2011)

**Figure 3.4 Outdoor Subsurface Irrigation Layout for Houses in Scottsdale**

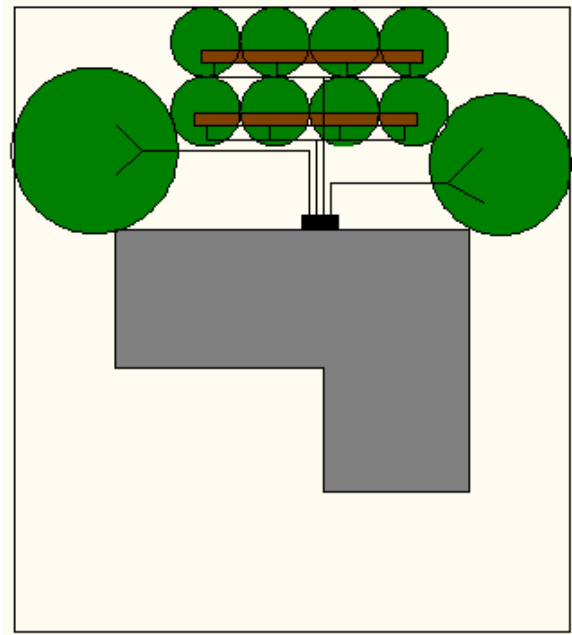

Note: The grey area is the house. The black box attached to the house is the tipper box, the brown box under the small trees is a mulch basin. Each black line represents 2" (50.8 mm) PVC pipe.  
From: (Gardels 2011)

**Figure 3.5 Outdoor Subsurface Irrigation Layout for Houses in Omaha**

In some climates, irrigation is not required year round. As a result, during months when irrigation is not required, the collected greywater must be diverted to the wastewater system. Therefore, a diverter valve is placed on the final greywater collection line that can be set to divert greywater through a pipe connecting to the wastewater line. The diverter valve must be accessible so it can be manually operated. In this scenario, the diverter valve is accessible through the basement ceiling.

### ***EPANET 2 Model of the Simple Greywater Reuse System***

The model of the simple greywater system for the typical house is created in EPANET 2. Values for node elevations, pipe length, Hazen-William coefficients and water demand are inserted into the model. In this model, the only water fixtures of interest are the bathroom sinks, showers, and washing machine because they are the greywater producers. In the model, flow control valves (FCV) are used to model the plumbing fixtures. A FCV allows only a specified flow rate through the valve. As a result, they can be programmed to be turned on and off to represent the use of the specified plumbing fixture. The elevations and pipe lengths are found from the house plans. A Hazen-Williams coefficient of 147 is used for the PVC pipe of the greywater system (Lamont 1981). The minor loss coefficients used in EPANET are listed in Table 3.4. In this scenario, a typical day is modeled using simple controls in EPANET 2. The water demand and fixture utilization are determined from Table 3.3.

**Table 3.4 Minor Loss Coefficients**

Type	Coefficient
T-flow through run	0.15
T-flow through branch	0.80
45° bend (radius/diameter = 1)	0.15
90° long elbow	0.15

From: (AWWA 2004)

Once the necessary data are entered into EPANET 2, multiple iterations are run to determine the minimum pipe diameters for the greywater collection pipes. The modeling results show that greywater collection pipes with a 1-inch (25.4 mm) diameter are adequate to handle the flows. However, 2-inch (50.8 mm) diameter pipes are selected over a 1-inch (25.4 mm) diameter pipe for the simple greywater system to reduce pipe clogging.

In this system, water from the upstairs bathroom is collected and then joins the greywater flow from the main bathroom. Then, water from the laundry and master bathroom enter the system. The main collection pipe exits the back of the house where the greywater is discharged to the subsurface irrigation system. A screenshot of the simple greywater system in EPANET 2 is shown in Figure 3.6.

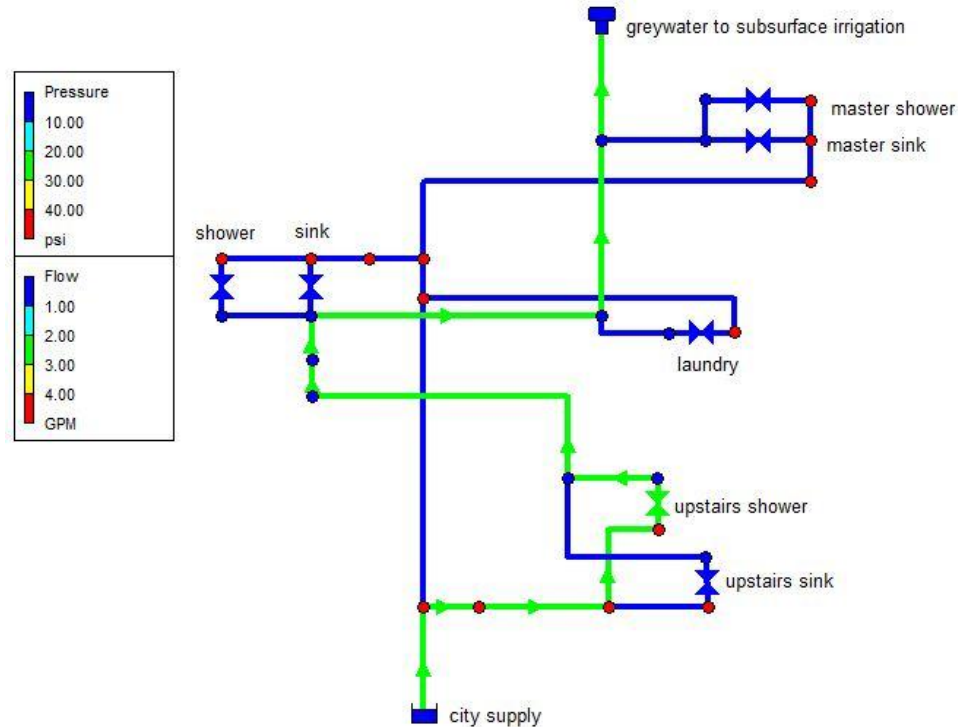

**Figure 3.6 Screenshot of the Simple Greywater Collection Scenario in EPANET 2.**

The different colors in the figure represent the different pipe flows and the pressures at each node. The red nodes signify pressurized flow, whereas the blue nodes signify non-pressurized flow. In the instance captured above, the upstairs shower is utilized. The arrows on the pipes show the flow path of the greywater. The EPANET 2 file for the simple greywater reuse and directions for using the model are in Appendix A.

### ***Additional Infrastructure Requirements***

Compared to a conventional plumbing system, the additional indoor infrastructure required for the simple greywater reuse scenario is minimal. The required materials are listed in Table 3.5. The materials required for the outdoor subsurface irrigation are given in Table 3.6 through Table 3.8. Note that the different outdoor infrastructure requirements for the different cities is a result of different irrigation areas.

**Table 3.5 Additional Indoor Infrastructure for the Simple Greywater Reuse Scenario.**

<b>Material</b>	<b>Amount</b>
2 in (50.8 mm) Schedule 40 PVC	132 ft (40.23 m)
2 in (50.8 mm) Schedule 40 PVC 90 degree elbows	6
2 in (50.8 mm) Schedule 40 PVC tee connections	7
2 in (50.8 mm) diverter valve	1

**Table 3.6 Additional Outdoor Infrastructure for the Simple Greywater Reuse Scenario in Seattle and Tampa.**

<b>Material</b>	<b>Amount</b>
1.5 in (38.1 mm) Schedule 40 ABS	36 ft (10.97 m)
2 in (50.8 mm) Schedule 40 ABS	102 ft (31.09 m)
90 degree Double ell	3
Plastic Dipper	1
Pre-cast Concrete Dipper Box	1
2 in (50.8 mm) to 1.5 in (38.1 mm) Reducer	6
45 degree Bend	2
30 degree Bend	2

From: (Gardels 2011)

**Table 3.7 Additional Outdoor Infrastructure for the Simple Greywater Reuse Scenario in Scottsdale**

<b>Material</b>	<b>Amount</b>
1.5 in (38.1 mm) Schedule 40 ABS	37 ft (11.28 m)
2 in (50.8 mm) Schedule 40 ABS	20 ft (6.10 m)
90 degree Double ell	3
Plastic Dipper	1
Pre-cast Concrete Dipper Box	1
2 in (50.8 mm) to 1.5 in (38.1 mm) Reducer	2
90 degree Elbows	2

From: (Gardels 2011)

**Table 3.8 Additional Outdoor Infrastructure for the Simple Greywater Reuse Scenario in Omaha**

<b>Material</b>	<b>Amount</b>
1.5 in (38.1 mm) Schedule 40 ABS	97 ft (29.57 m)
2 in (50.8 mm) Schedule 40 ABS	87 ft (26.52 m)
90 degree Double ell	8
Plastic Dipper	1
Pre-cast Concrete Dipper Box	1
2 in (50.8 mm) to 1.5 in (38.1 mm) Reducer	8
45 degree Bend	4
90 degree Elbows	2

From: (Gardels 2011)

### ***Greywater Uses***

In the simple greywater reuse scenario, the greywater is utilized for subsurface irrigation. No treatment is required for subsurface uses of greywater. The greywater collects in a tipper box outside the house. Once the box is full, the box tips and the water flows in underground pipes to mulch basins around trees and shrubs (Ludwig 2009).

### ***Benefits of Greywater Use***

The benefit of greywater use in the simple greywater reuse scenario is a reduction in the potable water demand. Watering plants with greywater reduces their irrigation demand from the potable water system. As a result, less water needs to be treated to potable drinking standards, and a reduction in the water bill occurs.

One drawback to the simple greywater system is the need to watch what products are used in the home. Detergents used for clothes washing and chemicals used to clean sinks and showers can have a negative impact on plant growth. Some chemicals to avoid are chlorine or bleach, peroxygen, sodium perborate, sodium trypochlorite, boron, and borax. Potassium based soaps are better suited for greywater reuse than sodium based soaps (Lancaster 2011).

### **3.3.3 Greywater Reuse System with Complex Greywater Collection and Treatment**

The complex greywater system collects the greywater from the showers and sinks within the house and then transports it to a treatment station in the basement of the house. Water from the washing machine is not collected as greywater in this scenario because treated greywater is used as the laundry water supply thus preventing the creation of a closed loop in the system. In addition, the water volume from the laundry is not needed because the uses of the greywater are satisfied from only bath water and bathroom sinks.

Treating the greywater improves the resulting water quality and increases the allowable end uses for the treated water. A small-scale greywater treatment system such as a membrane bioreactor can be used (Zhang et al. 2010). The greywater first enters a tank with chipped tires to begin the pretreatment process. The first tank also serves as an equalization tank. Then water enters the membrane bioreactor. Upon exiting the membrane bioreactor, the water is stored in a second tank. Water from the second tank is pumped to a pressure tank and then distributed to the toilets and clothes washer using a manifold system. The greywater collection and distribution plumbing is shown in Figure 3.7.



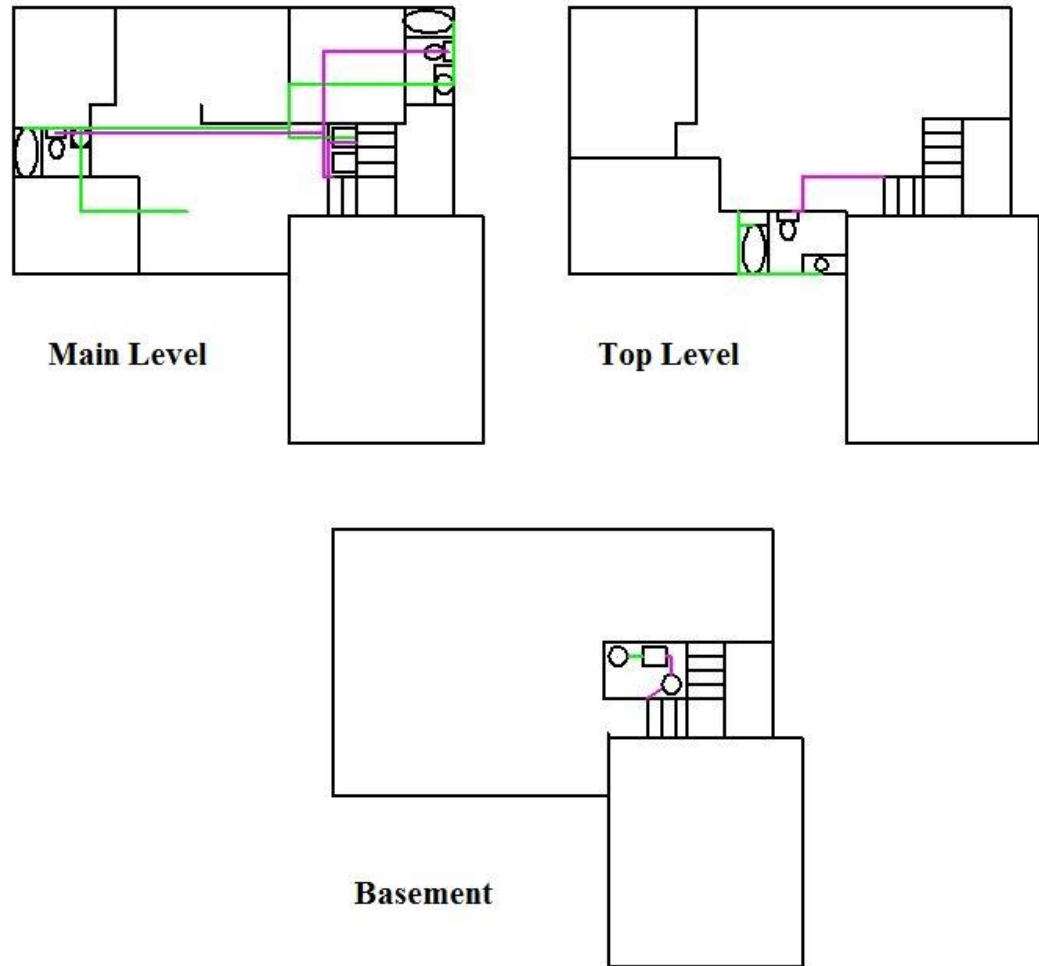

**Figure 3.7 Greywater Collection and Distribution System for Complex Greywater Collection with Treatment.**

The green lines are the greywater collection pipes and the purple lines are the treated greywater distribution pipes. The greywater is collected from the showers and sinks and treated in the basement with a membrane bioreactor. The treated greywater is then distributed to the toilets and laundry machine through PEX pipe.

***EPANET 2 Model of the Complex Greywater System with Treatment***

The model from the simple greywater reuse system is modified to accommodate a treatment step. First, the greywater enters a 75-gallon (283.9 liter) tank where greywater treatment occurs. Once the water has been treated, it enters a 65-gallon (246.1 liter) storage tank. A pump delivers the water from the storage tank to a 4.4-gallon (16.7 liter) pressure tank. A supply line connects the pressure tank to a manifold that distributes the

treated greywater through half-inch crosslinked polyethylene (PEX) lines connecting to each toilet and the laundry machine to distribute the treated greywater.

A pressure tank is used to keep the pump from short cycling. The pressure tank provides a 20-psi (138 kpa) differential. In this scenario, the pressure ranges from 20-40 psi (138-276 kpa). When the pressure drops to the lower limit, the pump will turn on until the maximum pressure is achieved. As a result, the pump does not need to run each time a fixture is used for a short duration.

The greywater treatment tank and the storage tank both have overflow valves, which connect to the wastewater system in the house. These valves ensure that water does not back up in the system. Likewise, the storage tank has a backup supply connection from the potable system. The connection has a backflow preventer valve that allows potable water to enter the storage tank if the amount of treated greywater is insufficient to meet the demand while ensuring no treated greywater enters the potable water system.

PEX is a material that is gradually replacing copper for potable distribution within the home. PEX is a temperature and pressure resistant flexible pipe that is composed of plastic polymers. The use of PEX in hot and cold water plumbing systems is approved for plumbing systems in the United States and is commonly used in European countries (Plastics Pipe Institute 2010). PEX is much cheaper than copper and is installed using a manifold. The use of a manifold allows the homeowner to turn off flow to individual fixtures. Some residences are plumbed using a PEX “homerun” system. In these houses, each fixture has its own set of hot and cold water lines that run from the manifold directly

to the plumbing fixture. The homerun system uses a large amount of PEX, so a modified “homerun” version is being used in this design where multiple fixtures are plumbed off one pair of lines. This method optimizes the benefits of the PEX system without using large amounts of PEX piping (Sweet 2010).

The Hazen-Williams coefficient used for PEX is 150 (Plastics Pipe Institute 2000). The Hazen-Williams coefficient used for PVC is 147 (Lamont 1981). The minor losses used in the model are located in Table 3.4. Minor losses are not used for the PEX pipe because the homerun system is used and there are no drastic bends; therefore, the minor losses are considered negligible for the PEX system.

The complex greywater collection and treatment system uses similar programming for a typical day as the simple greywater collection system. The only difference is that toilet flushes have also been programmed into the model because this system uses treated greywater to flush the toilets.

Figure 3.8 shows the EPANET 2 layout for the complex greywater collection with treatment scenario. In the figure, the toilet in the master bathroom is in use. Water flows from the pressure tank, to the manifold, through the PEX line and to the toilet. Simultaneously, the flush water from the toilet is exiting via the wastewater collection system.

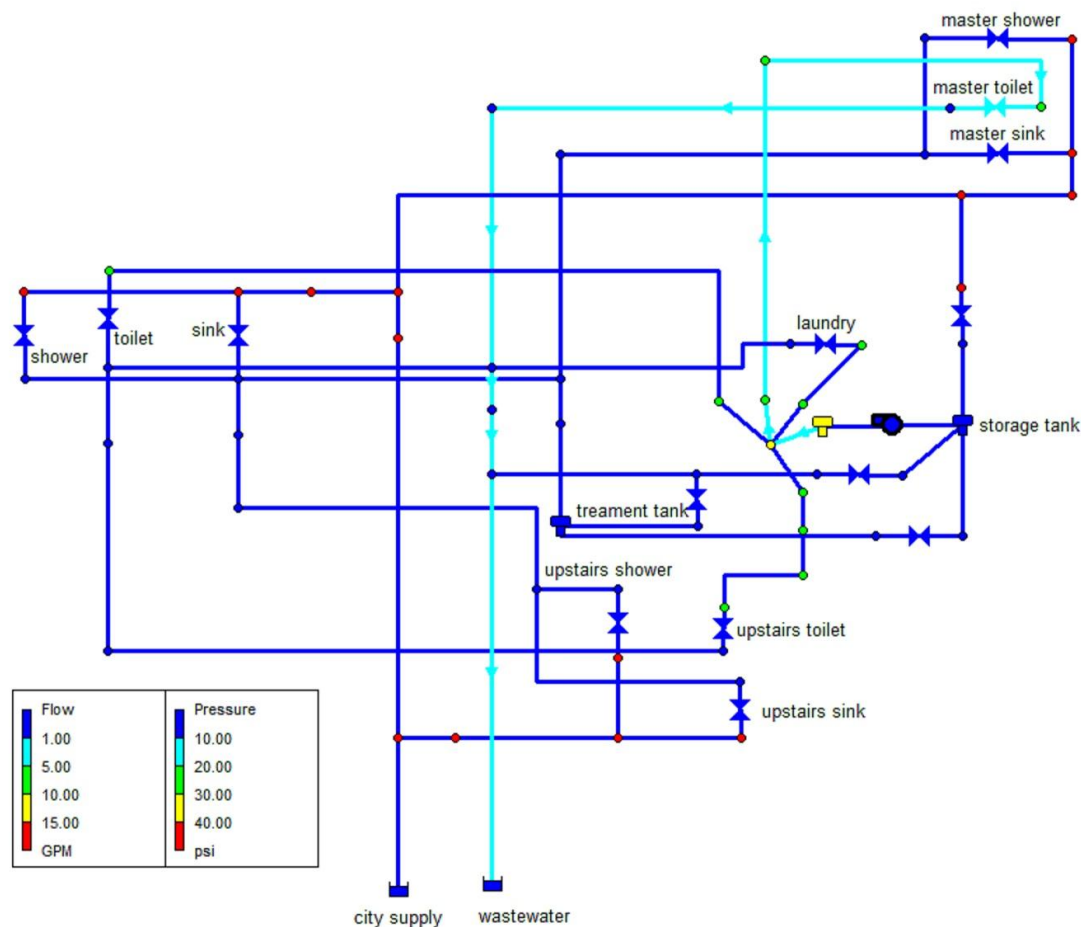

**Figure 3.8 EPANET 2 Layout for Complex Greywater System with Treatment.**

The water from the city supply line is at a higher pressure than the water from the treated greywater system. The main reason for this is that high water pressures are not required for the fixtures that use reclaimed water. For example, low flush toilets have a minimum pressure requirement of 8 psi (55.2 kpa) (Toto 2009). Likewise, the suggested pressure range for a washing machine is 20-100 psi (138-690 kpa) (Whirlpool 2009). Reducing the required pressure for the treated greywater distribution system reduces the costs associated with pumping the water.

One concern with using greywater is the storage time. Storing untreated greywater for 24 hours improves water quality because organic particles settle. However, untreated

greywater should not be stored for more than 48 hours otherwise the biological activity of the water can cause odor and sanitation problems (Dixon et al. 1999). As stated in Section 2.7.1, membrane treatment systems completely remove microorganisms, so concerns regarding the age and storage of the treated greywater are minimized (Asano 2007). EPANET 2 has a water age function that enables the time of the water in the system to be tracked.

Figure 3.9 shows the water age for water in each of the three tanks. The age reported is the total time the water has been in the system. As a result, this overestimates the age of the greywater because the water spends time in the system as potable water. Likewise, after treatment, the water age is not restarted as it enters the storage tank. Nevertheless, the results show that a typical house will use the water before the maximum storage time is reached.

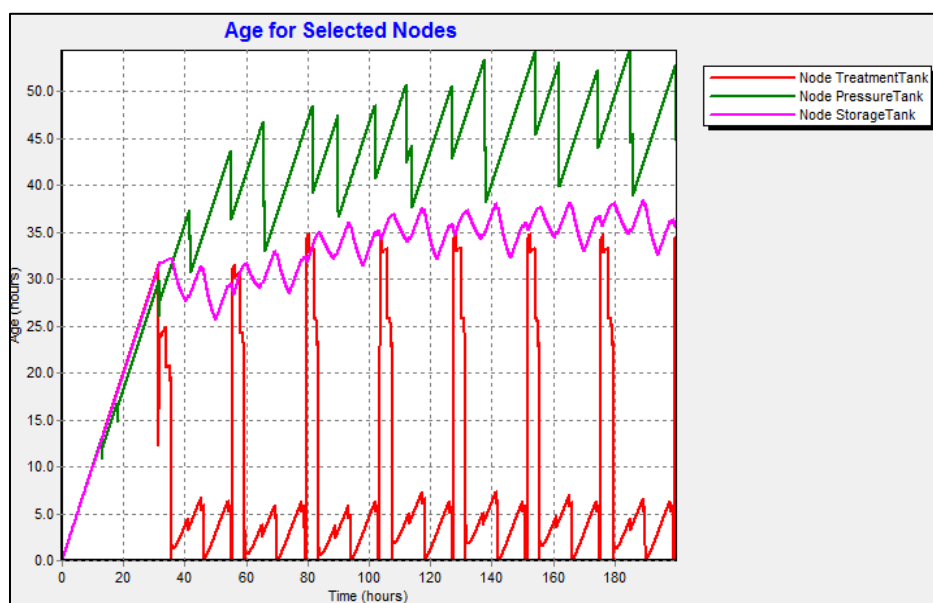

**Figure 3.9 Maximum Water Age for the Complex Greywater System with Treatment.**

The water age is cumulative starting when it first enters the network. The water age does not reset when it enters or exits a storage tank.

The EPANET 2 file for the greywater collection and treatment scenario and directions for how to use the program are located in Appendix A.

### ***Additional Indoor Infrastructure Required***

Compared to the conventional plumbing system, the additional infrastructure required for the greywater collection with treatment scenario is listed below in Table 3.9.

**Table 3.9 Materials List for Greywater Collection and Treatment Scenario.**

<b>Material</b>	<b>Amount</b>
2 in (50.8 mm) Schedule 40 PVC	102 ft (31.09 m)
2 in (50.8 mm) Schedule 40 PVC 90 degree elbows	7
2 in (50.8 mm) Schedule 40 PVC tee connections	7
Membrane Bioreactor Unit	1
65 gallon (246.1 liter) tank	1
75 gallon (283.9 liter) tank	1
Backflow Preventer	1
½ HP (373 watt) Franklin Electric VersaJet Pump (JVJ05CI)	1
PEX Manifold, 3, ½ in (12.7 mm) connections	1
4.4 gallon (16.7 liter) Amtrol pressure tank	1
½ in (12.7 mm) PEX	127 ft (38.71 m)

### ***Greywater Uses***

In the complex greywater treatment scenario, treated greywater is used for toilet flush water and laundry. The greywater is treated in a membrane bioreactor (MBR). MBR treatment completely removes microorganisms so disinfection is not needed.

### ***Benefits of Greywater Use***

Treating greywater on a household level leads to a potential water savings of 240 gallons (908.5 liters) per week. Water savings will be realized both in the potable and wastewater systems. The treatment process also provides another use for recycled tires by acting as a growing surface for microorganism involved in the pretreatment step.

One drawback with the complex greywater system with treatment is the maintenance associated with the treatment unit. The system will need to be inspected to ensure it is operating correctly and the filter media will need to be cleaned to prevent backup of debris. Another drawback is the extra energy required for pumping greywater and for aeration during treatment. It is estimated that the additional energy requirements are 513.5 kW per year (Gardels 2011).

### **3.3.4 Greywater Reuse System with Rainwater Harvesting**

In the final house scenario, the greywater system is the same as the collection and subsurface distribution system used in the simple greywater reuse scenario. In addition, rainwater is harvested from the roof and used for toilet flushing and laundry. Rainwater is used for toilet flushing and laundry instead of treated greywater because the rainwater has higher water quality and does not require treatment. The collected greywater is used for subsurface irrigation. This use does not require treatment. Therefore, the maximum amount of water reuse is achieved with minimum treatment expense (Zhang et al. 2010; Christova-Boal et al. 1996; Coombes and Barry 2007). The indoor plumbing layout for the Greywater Reuse System with Rainwater Harvesting is shown in Figure 3.10.

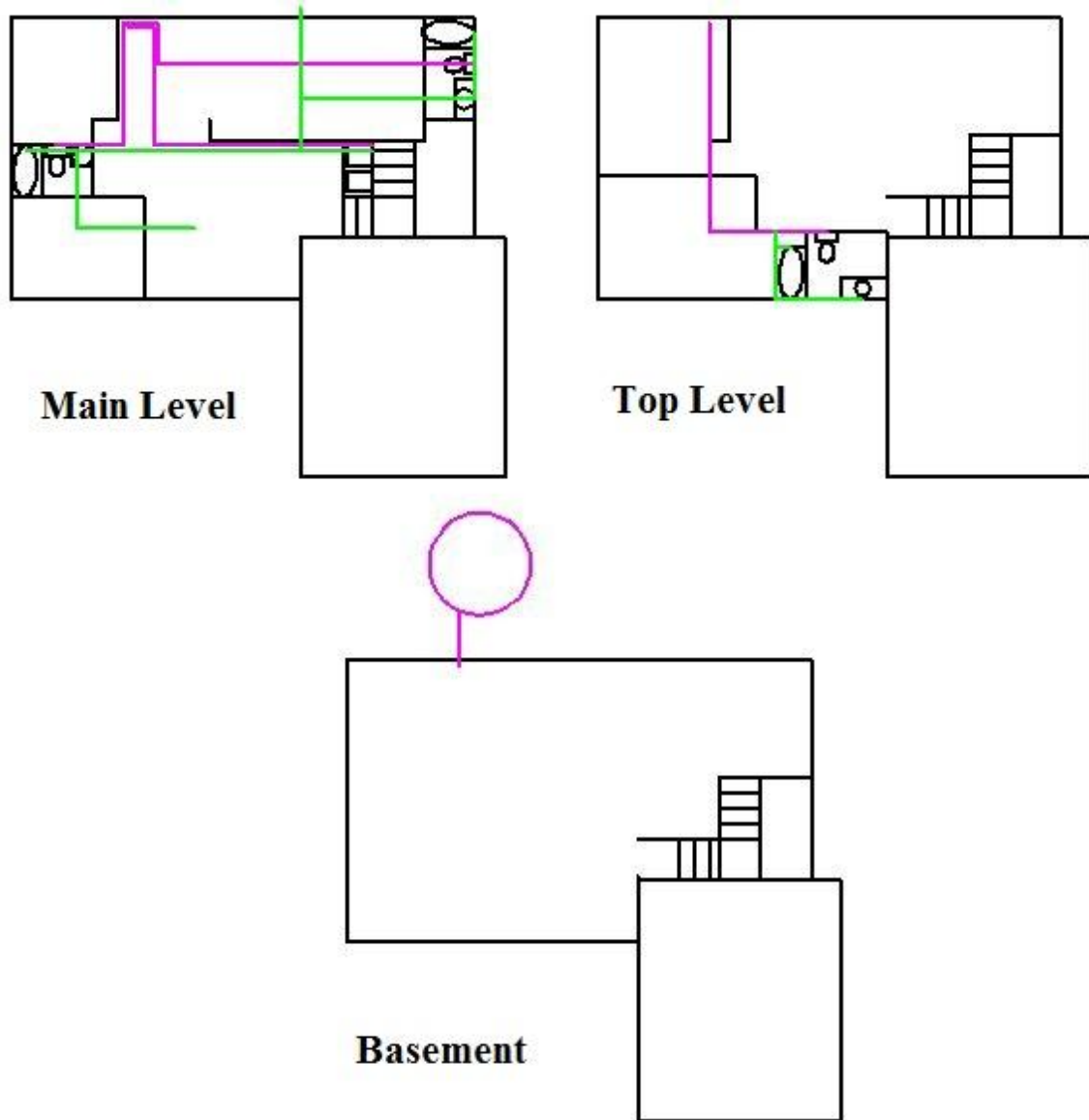

**Figure 3.10 Plumbing for Greywater Reuse System with Rainwater Harvesting.** Rainwater is collected in the underground cistern, which is then pumped into the house and distributed to the toilets, and laundry machine through a PEX piping system shown by the purple lines. The greywater is collected from the laundry, showers, and bathroom sinks, for outdoor subsurface irrigation.

To ensure the highest quality of rainwater possible is collected certain measures need to be taken. Residential roofs collect debris from trees, animals, and atmospheric deposition. All of these pollutants have a negative impact on the water quality of collected rainwater. However, the use of covered gutters, filters, and first flush diverters



can greatly improve the quality of rainwater collected. The purpose of the gutter covers and filter is to ensure that large debris such as leaves do not enter the rainwater cistern. The first flush diverter, diverts a predetermined amount of water away from the cistern. The first water that runs off from the roof contains the highest concentration of contaminants and is called the first flush. After the first flush, the quality of water collected is quite high (Lee et al. 2010; Huston et al. 2009; RainHarvest Systems 2010c).

The amount of water that should be diverted is dependent on the location of the house and the pollution load that typically occurs. RainHarvest Systems, a member of the U.S. Green Builders Council and American Rainwater Catchment Systems Association, recommends diverting 0.0125 gallons (0.047 liters) per square foot (0.09 square meters) on a house with minimal pollution and diverting 0.05 gallons (0.19 liters) per square foot (0.09 square meters) on a house with substantial pollution. Minimal pollution is defined as a roof that is in an open field with no trees, and no bird droppings whereas, substantial pollution is considered as a roof with leaves and other debris, bird droppings and other animal matter (RainHarvest Systems 2010a). For typical houses in an urban setting, the industry standard is to divert 10 gallons (37.85 liters) of rainwater for every 1,000 square feet (92.9 square meters) of roof (0.01 gallons per square foot, 0.41 liters per square meter) (Texas Water Development Board 2005; RainHarvest Systems 2010c)

First flush diverters include the diverter chamber and the slow release valve. The amount of water that must be diverted determines the corresponding length of pipe needed to capture the water. The required length of schedule 40 PVC pipe is connected to the diverter chamber on one end and the end cap with the slow release valve on the other end. The slow release valve should be at least 6 inches (15.24 cm) above the ground.

Longer lengths of pipe increase the amount of water that is diverted and provides a corresponding improvement in water quality in the cistern because more pollutants are captured. Table 3.10 below lists the storage capacity of 3 (76.2 mm), 4 (101.6 mm), and 12 inch (304.8) schedule 40 PVC pipe (RainHarvest Systems 2010a).

**Table 3.10 Capacity of 3, 4, and 12 inch Diameter Schedule 40 PVC Pipe**

Pipe Diameter		Storage Capacity	
in	mm	gal/ft	l/m
3	76.2	0.384034	4.77
4	101.6	0.661312	8.21
12	304.8	5.814633	72.21

The first flush diverter uses a floating ball and seat to ensure that contaminated water is not siphoned back into the system. As the water in the collection pipe rises, so does the floating ball. Once the pipe has reached capacity, the floating ball seals the chamber off by resting on the seat inside of the diverter, and water begins to flow to the cistern. After the rain, the slow release valve at the end of the collection pipe slowly releases water, automatically resetting the system (RainHarvest Systems 2010a).

In the collection system, the filter is placed before the first flush diverter. This configuration ensures no debris blocks or clogs the first flush diverter. The layout for the filter and first flush diverter is shown below in Figure 3.11.

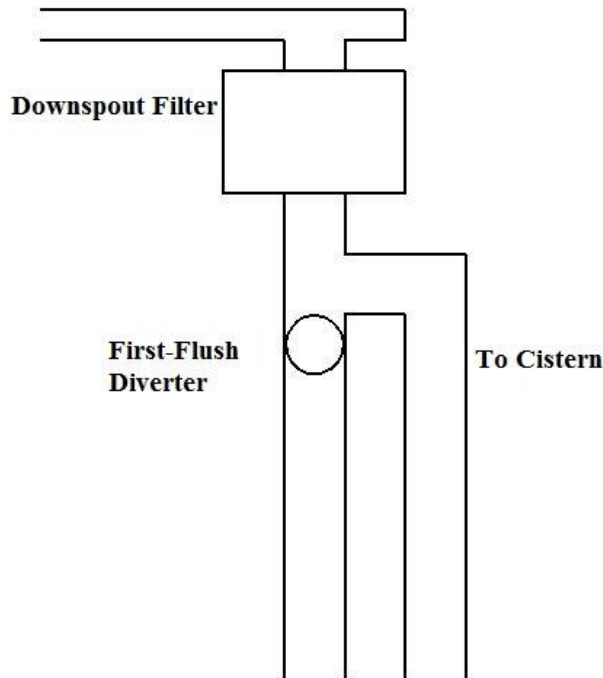

**Figure 3.11 Layout of Filter and First Flush Diverter for Rainwater Harvesting**

After the water passes by the first flush diverter, it travels to the cistern through an underground pipe system. Rainwater can be stored in either above-ground or below-ground cisterns. In this scenario, below-ground cisterns are used to ensure that water does not freeze in the cistern. From the cistern, the water is pumped into the house and distributed to the toilets and clothes washer via a pump and pressure tank system as in the greywater treatment and reuse scenario.

### ***Sizing Rainwater Harvesting System***

The National Standard Plumbing Code is used to determine the gutter, downspout, and horizontal collection pipe sizes (Plumbing-Heating-Cooling Contractors Association 2006). The plumbing code uses a design storm of duration of 60 minutes and a 100 year return period. The intensities for each city were found using an appendix in

the code. The values are given below in Table 3.11. Scottsdale is not listed so the value given for Phoenix is used.

**Table 3.11 Intensities for 60 minute, 100 year design storm.**

City	Intensity		Flow Rate from Roof Area	
	in/hr	mm/hr	gpm/ft <sup>2</sup>	lpm/m <sup>2</sup>
Seattle	1.0	25.40	0.010	0.407
Phoenix (Scottsdale)	2.2	55.88	0.023	0.937
Omaha	3.6	91.44	0.037	1.51
Tampa	4.2	106.68	0.044	1.79

From: (Plumbing-Heating-Cooling Contractors Association 2006)

The rainwater collection points and the area of the individual roof catchments are determined. Figure 3.12 shows the roof catchment divisions and the rainwater collection points (denoted by X's in Figure 3.12). Each collection point has a filter and first flush diverter. The blue line around the exterior of the house is the underground collection pipe used to transport the water from the downspouts to the underground cistern in the backyard.

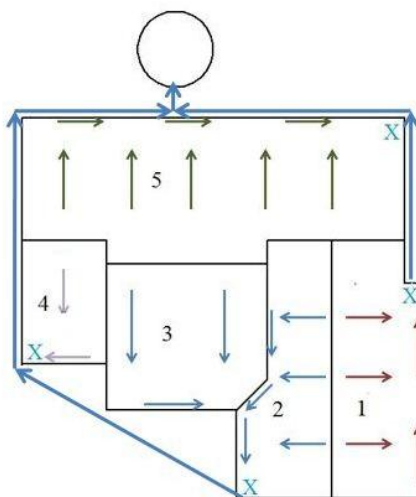

**Figure 3.12 Residential Roof Catchments and Rainwater Collection Points**

The roof catchment areas are listed in **Error! Reference source not found.** The water collected from areas 2, and 3 drains to the same collection point.

**Table 3.12 Residential Roof Catchment Areas**

Catchment Number	Area	
	ft <sup>2</sup>	m <sup>2</sup>
1	402.25	37.37
2	338.75	31.47
3	391	36.32
4	176	16.35
5	863	80.17
Total Area	2171	201.69

The downspout and gutter sizes are determined using Table 13.6.1 and Table 13.6.3, respectively in the National Standard Plumbing Code (Plumbing-Heating-Cooling Contractors Association 2006). These two tables are adapted for the rainfall intensity of the study cities below. The tables in the manual list the allowable square footage for the gutter and downspout diameter in 1 inch/hour rainfall intensity increments. Therefore, if the city of interest does not have an intensity of 1, 2, 3...6 in/hr the value must be adjusted. For example, a 3-inch (76.2 mm) diameter gutter with a rainfall intensity of 2.2 inch/hour (55.88 mm/hr) and slope of 1/16 inch/foot (5.2 mm/m) has an allowable collection area of 309 ft<sup>2</sup> (28.71 m<sup>2</sup>). This is determined by taking the allowable collection area for a 3-inch (76.2 mm) diameter gutter for an intensity of 4 inch/hour (106.68 mm/hr) which is 170 square feet (15.793 m<sup>2</sup>). Next, the allowable collection area at 4 inch/hour (106.68 mm/hr) is multiplied by the rainfall rate and divided by the desired rainfall rate. The example is shown below in equation form.

$$\text{Collection Area for 3 inch diameter gutter with } 2.2 \frac{\text{in}}{\text{hr}} = \frac{170 \text{ft}^2 \times 4 \frac{\text{in}}{\text{hr}}}{2.2 \frac{\text{in}}{\text{hr}}}$$

$$= 309 \text{ft}^2$$

Table 3.13 and Table 3.14 list the maximum allowable projected roof collection area for gutters and downspouts, respectively. Table 3.15 through Table 3.18 give the required downspout and gutter diameters for each study city.

**Table 3.13 Allowable Projected Roof Collection Area for Gutters by Study City Based on the Appropriate Rainfall Rate.**

Pipe Diameter		Allowable Projected Roof Area (ft <sup>2</sup> and m <sup>2</sup> )									
		Seattle		Scottsdale		Omaha		Tampa			
in	mm	4 in/hr	101.6 mm/hr	1 in/hr	25.4 mm/hr	2.2 in/hr	55.88 mm/hr	3.6 in/hr	91.44 mm/hr	4.2 in/hr	106.68 mm/hr
3	76.2	170	15.79	680	63.17	309	28.71	189	17.56	162	15.05
4	101.6	360	33.45	1440	133.78	655	60.85	400	37.16	343	31.87
5	127	625	58.06	2500	232.26	1136	105.54	694	64.47	595	55.28
6	152.4	960	89.18	3840	356.75	1745	162.12	1067	99.13	914	84.9
8	203.2	1380	128.21	5520	512.83	2509	233.09	1533	142.42	1314	122.08
10	254	3600	334.45	14400	133.78	6545	608.05	4000	371.61	3429	318.56

Gutter slope of 1/16 in per ft (5.21 mm/m)

Adapted from: (Plumbing-Heating-Cooling Contractors Association 2006)

**Table 3.14 Allowable Projected Roof Collection Area for Downspouts by Study City Based on the Appropriate Rainfall Rate**

Pipe Diameter		Allowable Projected Roof Area (ft <sup>2</sup> or m <sup>2</sup> )							
		Seattle		Scottsdale		Omaha		Tampa	
in	mm	1 in/hr	25.4 mm/hr	2.2 in/hr	55.88 mm/hr	3.6 in/hr	91.44 mm/hr	4.2 in/hr	106.68 mm/hr
3	76.2	6426	597.0	2921	271.37	1785	165.83	1530	142.14
4	101.6	13840	1285.78	6291	584.45	3844	357.12	3295	306.12

Adapted from: (Plumbing-Heating-Cooling Contractors Association 2006)

**Table 3.15 Seattle Required Downspout and Gutter Diameters**

Roof Catchment	Area		Downspout Diameter		Semicircular Gutter Diameter	
	ft <sup>2</sup>	m <sup>2</sup>	in	mm	in	mm
Area 1	402.25	37.37	3	76.2	3	76.2
Areas 2 & 3	729.75	67.80	3	76.2	4	101.6
Area 4	176	16.35	3	76.2	3	76.2
Area 5	863	80.18	3	76.2	4	101.6

**Table 3.16 Scottsdale Required Downspout and Gutter Diameters**

Roof Catchment	Area		Downspout Diameter		Semicircular Gutter Diameter	
	ft <sup>2</sup>	m <sup>2</sup>	in	mm	in	mm
Area 1	402.25	37.37	3	76.2	4	101.6
Areas 2 & 3	729.75	67.80	3	76.2	5	127.0
Area 4	176	16.35	3	76.2	3	76.2
Area 5	863	80.18	3	76.2	5	127.0

**Table 3.17 Omaha Required Downspout and Gutter Diameters**

Roof Catchment	Area		Downspout Diameter		Semicircular Gutter Diameter	
	ft <sup>2</sup>	m <sup>2</sup>	in	mm	in	mm
Area 1	402.25	37.37	3	76.2	5	127.0
Areas 2 & 3	729.75	67.80	3	76.2	6	152.4
Area 4	176	16.35	3	76.2	3	76.2
Area 5	863	80.18	3	76.2	6	152.4

**Table 3.18 Tampa (4.2 in/hr) Required Downspout and Gutter Diameters**

Roof Catchment	Area		Downspout Diameter		Semicircular Gutter Diameter	
	ft <sup>2</sup>	m <sup>2</sup>	in	mm	in	mm
Area 1	402.25	37.37	3	76.2	5	127.0
Areas 2 & 3	729.75	67.80	3	76.2	6	152.4
Area 4	176	16.35	3	76.2	4	101.6
Area 5	863	80.18	3	76.2	6	152.4

The gutters and downspouts are not being considered extra material required for the water system. The rationale is that although rainwater harvesting may change the size

and type of gutters used (i.e. gutters with leaf shields) all residences currently have gutters and downspouts.

As mentioned previously, first flush diverters are used to reduce the contaminant load in the cistern. The amount of water diverted is dependent on the catchment area and condition. The industry standard of 10 gallons (37.86 l) per 1000 square feet (92.9 m<sup>2</sup>) by RainHarvest Systems (2010) is used for this study. Since the downspout diameter is 3 inches (76.2 mm), 3-inch (76.2 mm) first flush diverters are used. Since the roof area is the same in all four locations, the same amount of water needs to be diverted. Therefore, the length of PVC diverter collection pipe required is the same for all of the locations. The storage capacity of 3-inch (76.2 mm) schedule 40 PVC pipe is given in Table 3.10. The length of pipe required at each downspout is listed below in Table 3.19. Catchment areas 2 & 3, and area 5 require 19 feet (5.79 m) and 22.5 feet (6.71 m) of 3-inch (76.2 mm) PVC pipe, respectively. However, the gutters are located 19 feet (5.79 m) above the ground, and the filter is located 0.5 feet (0.15 m) below the gutter and has a height of approximately 1 foot (0.30 m). Including, the required 0.5 feet (0.15 m) of clearance above the ground required for the slow release valve, the maximum length of capture pipe for the first flush diverter is 17 feet (5.18 m). This length provides less than the desired 0.01 gal/ft<sup>2</sup> (0.41 l/m<sup>2</sup>) diversion, but it provides diversion volumes of 0.009 gal/ft<sup>2</sup> (0.37 l/m<sup>2</sup>) and 0.008 gal/ft<sup>2</sup> (0.33 l/m<sup>2</sup>) for roof areas 2 & 3 and 5, respectively. The length of pipe for these two areas is not ideal, but it should sufficiently remove contaminants. If this is of concern to the homeowner, the downspout diameter could be increased to 4-inches (101.6 mm) thus increasing the storage capacity given the limit of 17 feet (5.18 m) of pipe.



**Table 3.19 Required Amount of Storage Capacity for First Flush Diverters and Corresponding Length of 3-inch PVC Pipe.**

Catchment	Area		Water Diverted		Length	
	ft <sup>2</sup>	m <sup>2</sup>	gal	l	ft	m
Area 1	402.25	37.37	4.02	15.22	10.5	3.20
Areas 2 & 3	729.75	67.80	7.30	27.63	17.0*	5.18*
Area 4	176	16.35	1.76	6.66	4.6	1.40
Area 5	863	80.18	8.63	32.67	17.0*	5.18*
Total	2171	201.70	21.71	82.18	49.1	14.97

\*The maximum space between the gutter and the ground is 17 feet (5.18 m).

Next, the underground pipe leading to the cistern is sized. One important aspect of the design is to ensure the cistern is located below the local frost line. The maximum depths of frost penetration for the study cities are listed in Table 3.20.

**Table 3.20 Frost Penetration in Study Cities**

City	Frost Depth	
	ft	m
Seattle	0.755	0.23
Scottsdale	0.653	0.20
Omaha	3.281	1.00
Tampa	0.328	0.01

From: (Floyd 1978)

The underground collection pipe A collects water from areas 2 and 3 (blue line in Figure 3.13). The water continues in the underground pipe A and connects with the water from area 4. The pipe from this side of the house then connects to the cistern. On the other side of the house, water from area 1 (green line in Figure 3.13) flows to the back corner in pipe B, where it is then joined by water from area 5. Pipe B connects to pipe A from the other side of the house in a T intersection and then continues to the cistern in pipe C (red line in Figure 3.13).

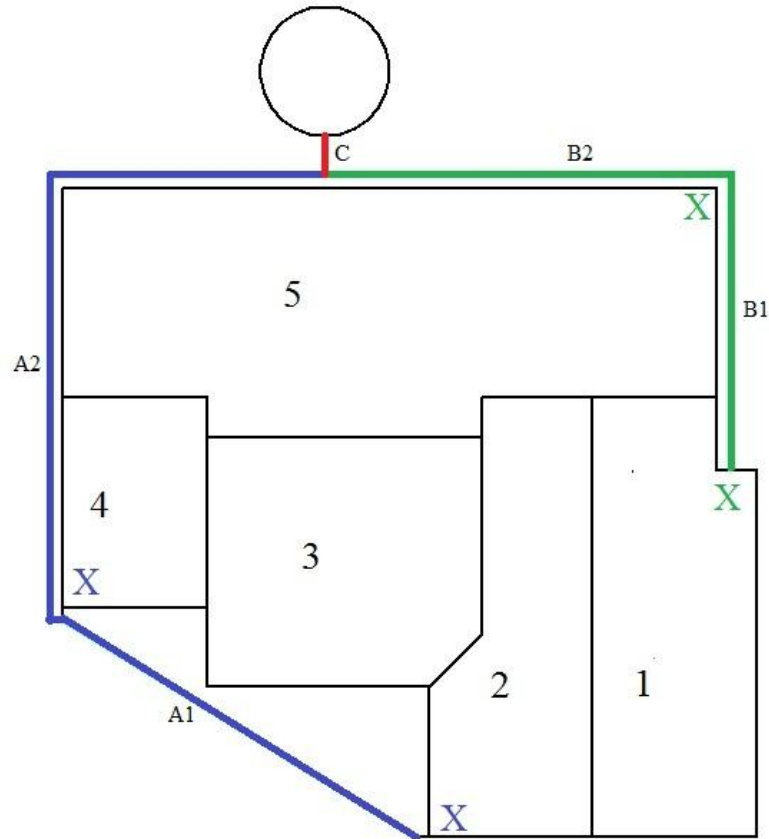

**Figure 3.13 Residential Underground Piping Layout**

The diameters of the horizontal collection pipes are determined using the National Standard Plumbing Code (Plumbing-Heating-Cooling Contractors Association 2006). The pipe slope for all the locations except Omaha is 1/8 inch per foot (10.4 mm/m). The Omaha design uses a slope of 1/4 inch per foot (20.8 mm/m). The increased slope in Omaha is required because the cistern must be deeper to be below the frost line. The horizontal collection pipes are designed based on the flow rate. The required pipe diameters for the horizontal collection system are shown in Table 3.21 through Table 3.24.

**Table 3.21 Seattle (0.010 gpm/ft<sup>2</sup>) Required Underground Pipe Diameter Using 1/8 in/ft Pipe Slope.**

Pipe	Flow Rate		Pipe Diameter	
	gpm	lpm	in	mm
A	9.06	34.30	3	76.2
B	12.66	47.92	3	76.2
C	21.71	82.18	3	76.2

**Table 3.22 Scottsdale (0.023 gpm/ft<sup>2</sup>) Required Underground Pipe Diameter Using 1/8 in/ft Pipe Slope.**

Pipe	Flow Rate		Pipe Diameter	
	gpm	lpm	in	mm
A	20.83	78.85	3	76.2
B	29.10	110.16	3	76.2
C	49.93	189.00	4	101.6

**Table 3.23 Omaha (0.037 gpm/ft<sup>2</sup>) Required Underground Pipe Diameter Using 1/4 in/ft Pipe Slope.**

Pipe	Flow Rate		Pipe Diameter	
	gpm	lpm	in	mm
A	33.51	126.85	3	76.2
B	46.81	177.20	3	76.2
C	80.33	304.08	4	101.6

**Table 3.24 Tampa (0.044 gpm/ft<sup>2</sup>) Required Underground Pipe Diameter Using 1/8 in/ft Pipe Slope.**

Pipe	Flow Rate		Pipe Diameter	
	gpm	lpm	in	mm
A	39.85	150.85	4	101.6
B	55.67	210.73	4	101.6
C	95.52	361.58	5	127.0

Finally, the length of pipe needed for the underground system is determined.

Figure 3.14 describes the terminology used in Table 3.25 through Table 3.28. The total pipe length listed in the table is the sum of the length of pipe and the elevation difference. The depth to the top of the cistern in all cities is 1.5 feet (0.46 m) except for Omaha where the depth is 3.5 feet (1.07 m).

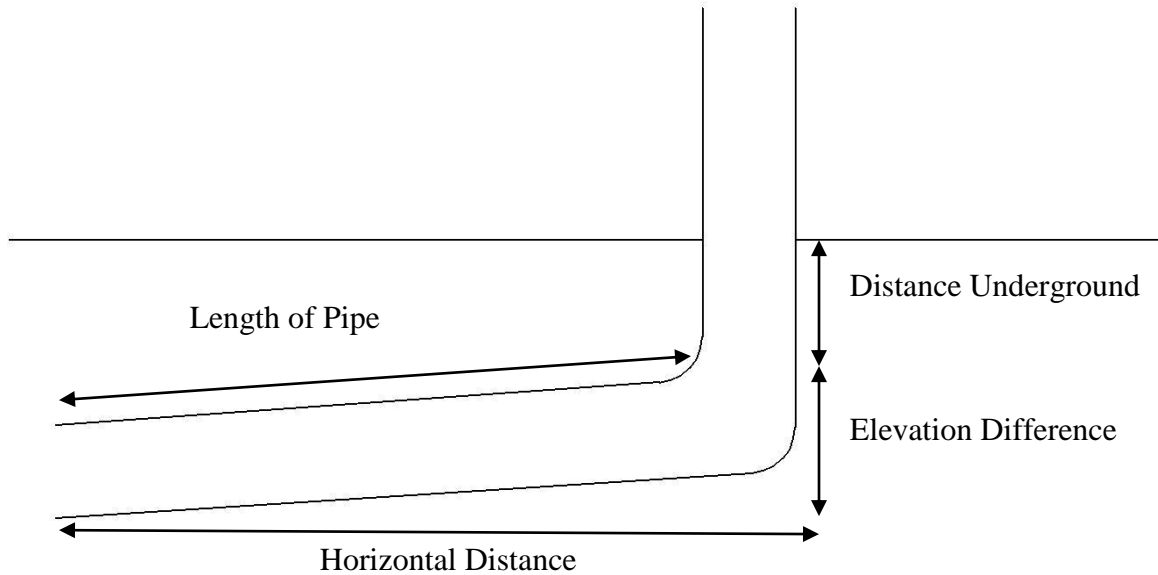

Figure 3.14 Definition of Terminology Used in Table 3.25 through Table 3.28.

Table 3.25 Underground Pipe Requirements for Seattle

Pipe	Horizontal Distance		Elevation Difference		Distance Underground		Total Length of Pipe		Pipe Diameter	
	ft	m	ft	m	ft	m	ft	m	in	mm
A1	31.64	9.64	0.33	0.10	0.57	0.17	32.21	9.82	3	76.2
A2	55	16.76	0.57	0.17	0.90	0.27	55.90	17.04	3	76.2
B1	22.5	6.86	0.23	0.07	0.92	0.28	23.42	7.14	3	76.2
B2	31	9.45	0.32	0.10	1.15	0.35	32.15	9.80	3	76.2
C	3	0.91	0.03	0.009	-		3	0.91	3	76.2
Summary							146.68	44.71	3	76.2

Table 3.26 Underground Pipe Requirements for Scottsdale.

Pipe	Horizontal Distance		Elevation Difference		Distance Underground		Total Length of Pipe		Pipe Diameter	
	ft	m	ft	m	ft	m	ft	m	in	mm
A1	31.64	9.64	0.33	0.10	0.57	0.17	32.21	9.82	3	76.2
A2	55	16.76	0.57	0.17	0.90	0.27	55.90	17.04	3	76.2
B1	22.5	6.86	0.23	0.07	0.92	0.28	23.42	7.14	3	76.2
B2	31	9.45	0.32	0.10	1.15	0.35	32.15	9.80	3	76.2
C	3	0.91	0.03	0.009	-		3	0.91	4	101.6
Summary							143.68	43.79	3	76.2
							3	0.91	4	101.6

**Table 3.27 Underground Pipe Requirements for Omaha.**

Pipe	Horizontal Distance		Elevation Difference		Distance Underground		Total Length of Pipe		Pipe Diameter	
	ft	m	ft	m	ft	m	ft	m	in	mm
A1	31.64	9.64	0.33	0.10	0.57	0.17	32.21	9.82	3	76.2
A2	55	16.76	0.57	0.17	0.90	0.27	55.90	17.04	3	76.2
B1	22.5	6.86	0.47	0.14	2.32	0.71	24.82	7.57	3	76.2
B2	31	9.45	0.65	0.20	2.79	0.85	33.79	10.30	3	76.2
C	3	0.91	0.063	0.019	-		3	0.91	4	101.6
Summary							149.2	45.48	3	76.2
							3	0.91	4	101.6

**Table 3.28 Underground Pipe Requirements for Tampa.**

Pipe	Horizontal Distance		Elevation Difference		Distance Underground		Total Length of Pipe		Pipe Diameter	
	ft	m	ft	m	ft	m	ft	m	in	mm
A1	31.64	9.64	0.33	0.10	0.57	0.17	32.21	9.82	4	101.6
A2	55	16.76	0.57	0.17	0.90	0.27	55.90	17.04	4	101.6
B1	22.5	6.86	0.23	0.07	0.92	0.28	23.42	7.14	4	101.6
B2	31	9.45	0.32	0.10	1.15	0.35	32.15	9.80	4	101.6
C	3	0.91	0.03	0.009	-		3	0.91	5	127
Summary							143.68	43.79	4	101.6
							3	0.91	5	127

Table 3.25 through Table 3.28 summarize the pipe lengths and diameters required for the underground piping systems. However, for this study, when two different pipe diameters are required (e.g., Scottsdale, Omaha, and Tampa), the largest pipe diameter is used for the entire system.

The cistern for each location is sized using Rainwater Harvester 2.0, which was developed at North Carolina State University (Jones 2010). The required size for the cistern in all locations is 2500 gallons (9464 l) (Gardels 2011). The cistern has an overflow system, which releases excess water through a 10 ft (3.05 m), 3 in (76.2 mm)

diameter PVC pipe. Two backflow valves are used in the system, one at the outlet of the overflow pipe (to close the system to outside contaminants) and one before the water enters the cistern. The use of backflow valves keeps unwanted contaminants from entering the system when it is not raining. The use of two backflow valves will create a closed system around the cistern. The materials required for the rainwater harvesting system are summarized in Table 3.29 through Table 3.32..

**Table 3.29 Materials for Rainwater Harvesting Required by All Locations**

<b>Material</b>	<b>Amount</b>
First Flush Diverter Unit for 3 inch (76.2 mm) PVC Pipe	4
Downspout Filter	4
3 inch (76.2 mm) Diameter PVC Pipe (Cistern Overflow and First Flush Collection)	59.1 ft (18 m)
Backflow Valves	2
3 inch (76.2 mm) PVC Elbows	4
2500 gallon (9464 l) Cistern	1

**Table 3.30 Rainwater Harvesting Materials Required for Seattle and Scottsdale**

<b>Material</b>	<b>Amount</b>
3 inch (76.2 mm) Diameter Schedule 40 PVC	146.68 ft (44.71 m)
3 inch (76.2 mm) Diameter Schedule 40 PVC Elbow	4
3 inch (76.2 mm) Diameter Schedule 40 PVC Tee Connection	3

**Table 3.31 Rainwater Harvesting Materials Required for Omaha**

<b>Material</b>	<b>Amount</b>
4 inch (101.6 mm) Diameter Schedule 40 PVC	152.2 ft (46.4 m)
4 inch (101.6 mm) Diameter Schedule 40 PVC Elbow	4
4 inch (101.6 mm) Diameter Schedule 40 PVC Tee Connection	3

**Table 3.32 Rainwater Harvesting Materials Required for Tampa**

<b>Material</b>	<b>Amount</b>
5 inch (127 mm) Diameter Schedule 40 PVC	146.68 ft (44.71 m)
5 inch (127 mm) Diameter Schedule 40 PVC Elbow	4
5 inch (127 mm) Diameter Schedule 40 PVC Tee Connection	3

### ***EPANET 2 Model of the Greywater Reuse System with Rainwater Harvesting***

In the greywater reuse system with rainwater harvesting residential scenario, the greywater is collected and used outside for subsurface irrigation. The greywater collection system is the same as the simple greywater collection system shown in Figure 3.6. The rainwater harvesting system is not modeled in EPANET 2. The rainwater system is modeled as a reservoir. As mentioned previously, the cisterns were sized using Rainwater Harvester 2.0 (Jones 2010). Therefore, in the EPANET 2 model, it is assumed that water is always available from the cistern. If the cistern is low, a backup potable water supply is used to meet the demands from the cistern (i.e., toilet flushing and clothes washing). The rainwater distribution system is similar to the treated greywater distribution system used in the complex greywater system with treatment scenario.

The cistern is located in the backyard. Water from the rainwater cistern is pumped to a pressure tank. From the pressure tank, the water goes to a manifold that distributes the water to the three toilets in the house and the laundry machine. PEX is used as the piping material for the distribution system. The minor loss coefficients are listed in Table 3.4, and a Hazen-Williams coefficient of 147 is used for the PVC pipe (Lamont 1981). A Hazen-Williams coefficient of 150 is used for the PEX pipe (Plastics Pipe Institute 2000). Minor losses are negligible in the PEX system because homerun piping is used and drastic direction changes are avoided. Figure 3.15 is a screenshot of the EPANET 2 model for this scenario.

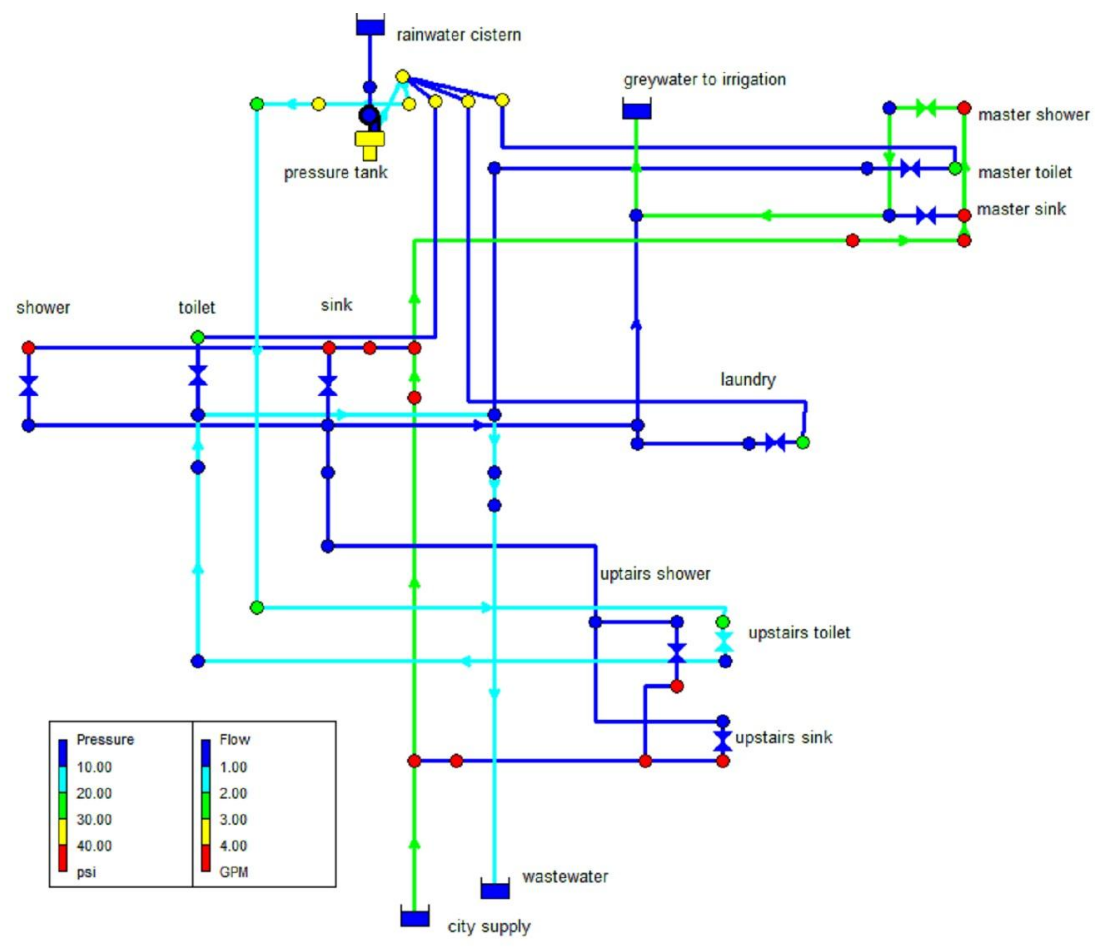

**Figure 3.15 EPANET 2 Model for Rainwater Harvesting and Greywater Reuse Scenario.**

In Figure 3.15, the shower in the master bathroom is in use as is the upstairs toilet. The greywater from the shower is collected and piped to the tipper box located in the backyard. Water for the toilet comes from the pressure tank, through the manifold and PEX pipe to the upstairs toilet, while the flushed water exits the house through the wastewater system.

The fixture pressure requirements are the same as mentioned in Section 3.3.3, subsection EPANET 2 model. The typical day modeling for Scenario 3 is also the same as the complex greywater system with treatment scenario. The EPANET file for the



Rainwater Harvesting and Greywater Reuse Scenario and directions on how to run the program are located in Appendix A.

### ***Additional Infrastructure Required***

Compared to a conventional plumbing system, the additional infrastructure required for the rainwater harvesting system is listed in Table 3.29 through Table 3.32. The indoor plumbing requirements for the rainwater harvesting and greywater reuse scenario are shown below in Table 3.33. The outdoor material requirements for subsurface irrigation for each city are shown in Table 3.34 through Table 3.37.

**Table 3.33 Indoor Plumbing Material Requirements for Rainwater Harvesting and Greywater Reuse Scenario.**

<b>Material</b>	<b>Amount</b>
1 in (25.4 mm) Schedule 40 PVC (bring rainwater into house)	5.5 ft (1.68 m)
½ in (12.7 mm) PEX (distribute rainwater within house)	163.5 ft (49.83 m)
2 in (50.8 mm) Schedule 40 PVC (greywater collection system)	114.5 ft (34.90 m)
2 in (50.8 mm) Schedule 40 PVC Elbows (greywater collection)	7
2 in (50.8 mm) Schedule 40 PVC Tees (greywater collection)	5
Backflow Preventer (Potable Supply Backup)	1
½ HP (373 watt) Franklin Electric VersaJet Pump (JVJ05CI)	1
4.4 gallon (16.7 liter) Amtrol pressure tank	1

**Table 3.34 Outdoor Plumbing Material Requirements for Subsurface Irrigation in Rainwater Harvesting and Greywater Reuse Scenario in Seattle.**

<b>Material</b>	<b>Amount</b>
1.5 in (38.1 mm) Schedule 40 PVC	36 ft (10.97 m)
2 in (50.8 mm) Schedule 40 PVC	70 ft (21.34 m)
2 in (50.8 mm) Schedule 40 PVC Tees	3
2 in (50.8 mm) to 1.5 in (38.1 mm) Schedule 40 PVC Reducers	3
2 in (50.8 mm) Schedule 40 PVC 45 degree Bend	4
2 in (50.8 mm) Schedule 40 PVC 90 degree Elbow	4
3 in (76.2 mm) Schedule 40 PVC Pipe	147 ft (44.81 m)
3 in (76.2 mm) Schedule 40 PVC 90 degree Elbow	4
3 in (76.2 mm) Schedule 40 PVC Tees	3
Plastic Dipper	1
Pre-Cast Concrete Dipper Box	1

**Table 3.35 Outdoor Plumbing Material Requirements for Subsurface Irrigation in Rainwater Harvesting and Greywater Reuse Scenario in Scottsdale**

<b>Material</b>	<b>Amount</b>
1.5 in (38.1 mm) Schedule 40 PVC	14 ft (4.27 m)
2 in (50.8 mm) Schedule 40 PVC	14 ft (4.27 m)
2 in (50.8 mm) Schedule 40 PVC Tees	1
2 in (50.8 mm) to 1.5 in (38.1 mm) Schedule 40 PVC Reducers	1
2 in (50.8 mm) Schedule 40 PVC 90 degree Elbow	2
4 in (101.6 mm) Schedule 40 PVC Pipe	147 ft (44.81 m)
4 in (101.6 mm) Schedule 40 PVC 90 degree Elbow	4
4 in (101.6 mm) Schedule 40 PVC Tees	3
Plastic Dipper	1
Pre-Cast Concrete Dipper Box	1

**Table 3.36 Outdoor Plumbing Material Requirements for Subsurface Irrigation in Rainwater Harvesting and Greywater Reuse Scenario in Omaha**

<b>Material</b>	<b>Amount</b>
1.5 in (38.1 mm) Schedule 40 PVC	59 ft (17.98)
2 in (50.8 mm) Schedule 40 PVC	76 ft (23.16 m)
2 in (50.8 mm) Schedule 40 PVC Tees	5
2 in (50.8 mm) to 1.5 in (38.1 mm) Schedule 40 PVC Reducers	3
2 in (50.8 mm) Schedule 40 PVC 45 degree Bend	4
2 in (50.8 mm) Schedule 40 PVC 90 degree Elbow	4
4 in (101.6 mm) Schedule 40 PVC Pipe	153 ft (46.63 m)
4 in (101.6 mm) Schedule 40 PVC 90 degree Elbow	4
4 in (101.6 mm) Schedule 40 PVC Tees	3
Plastic Dipper	1
Pre-Cast Concrete Dipper Box	1

**Table 3.37 Outdoor Plumbing Material Requirements for Subsurface Irrigation in Rainwater Harvesting and Greywater Reuse Scenario in Tampa**

<b>Material</b>	<b>Amount</b>
1.5 in (38.1 mm) Schedule 40 PVC	59 ft (17.98 m)
2 in (50.8 m) Schedule 40 PVC	76 ft (23.16 m)
2 in (50.8 mm) Schedule 40 PVC Tees	5
2 in (50.8 mm) to 1.5 in (38.1 mm) Schedule 40 PVC Reducers	3
2 in (50.8 mm) Schedule 40 PVC 45 degree Bend	4
2 in (50.8 mm) Schedule 40 PVC 90 degree Elbow	4
4 in (101.6 mm) Schedule 40 PVC Pipe	153 ft (46.63 m)
4 in (101.6 mm) Schedule 40 PVC 90 degree Elbow	4
4 in (101.6 mm) Schedule 40 PVC Tees	3
Plastic Dipper	1
Pre-Cast Concrete Dipper Box	1

### ***Benefits of Greywater and Rainwater Use***

The main benefit of rainwater harvesting is that the use of rainwater for toilet flushing and clothes washing decreases the potable water demand, and the rainwater is free. Using untreated greywater for subsurface irrigation further reduces the potable water demand and provides nutrients for the plants.

One potential drawback of the rainwater harvesting system is the maintenance of the system to ensure optimal operation. The roof will need to be cleaned of debris during dry periods to reduce the pollutant load that enters the rainwater system. A negative for the greywater system is the need to watch what products are used in the clothes washing, showering, and hand washing. Bleach and other chemicals will negatively impact plant health.

### **3.4 Apartment Building**

The fourth scenario analyzed is an apartment building. The apartment building has 60 apartments per floor and 3 floors. Each floor has 4, 3-bedroom apartments, 32, 2-bedroom apartments, and 24, 1-bedroom apartments. The assumed number of occupants in the building is 300, or 1 person occupying each bedroom in the building. Each floor of the apartment is approximately 82,000 square feet (7617 m<sup>2</sup>). The floor plans for the apartment building are shown below in Figure 3.16, and the layouts for the individual apartments are shown in Figure 3.17

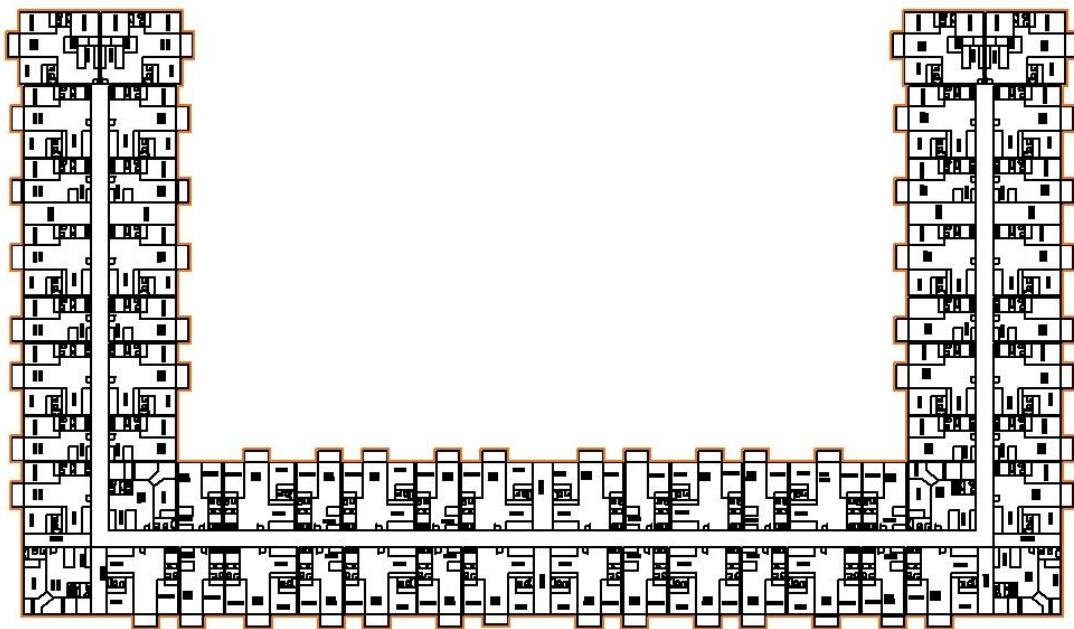

**Figure 3.16 Apartment Building Layout**

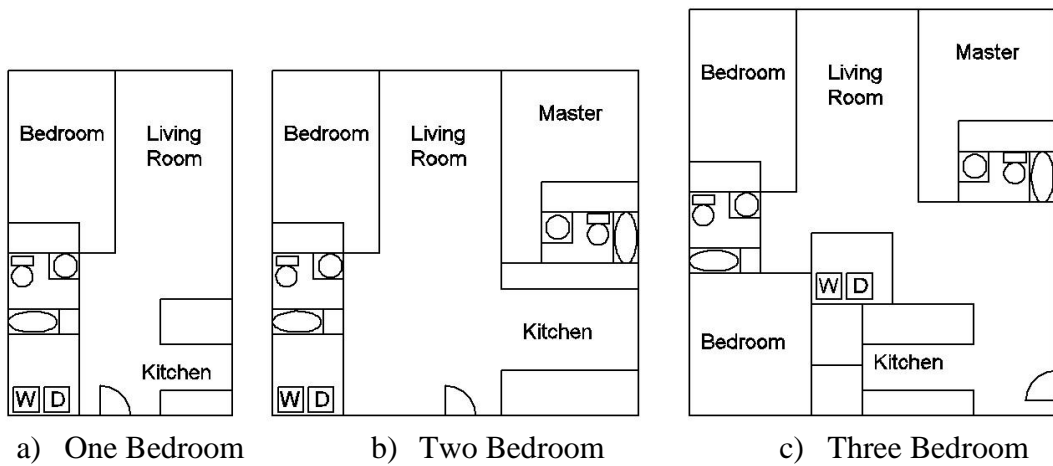

**Figure 3.17 Individual Apartment Layouts.**

The apartment scenario utilizes rainwater for toilet flushing and laundry. Rainwater is collected from the roof and stored in a cistern. The water is then pumped to a pressure tank where it is distributed to each floor and then to each apartment. Water to each floor is distributed through 3-inch (76.2 mm) schedule 40 PVC pipe. On each floor, 2-inch

(50.8 mm) schedule 40 PVC pipe is used to deliver the water to each apartment. Within each apartment, the PVC line from the hallway connects to a manifold in the laundry room. From there, ½ -inch (12.7 mm) PEX is used to transport the water to the toilet(s) and washing machine in the apartment. PEX is not used for the entire plumbing system because it is not readily available in diameters larger than 1-inch (25.4 mm).

### **3.4.1 Rainwater Harvesting**

In this scenario, rainwater will be harvested from the roof of the apartment building using the same methods as employed in the residential rainwater harvesting scenario. The main variation is that different first-flush diverters will be used. Instead of using diverters that attach to the downspouts, underground diverters are used. The underground diverters utilize 12-inch (304.8 mm) diameter pipe, which allows for more storage capacity in a shorter length of pipe. In order to use the underground diverters, a pipe slope of 1:12 is needed to allow the diverters to drain after the storm (RainHarvest Systems 2010b). The ground must also have a slope of 1:12 so the end of the pipe is above ground allowing the water to drain from the diverter to the surrounding land surface. See Section 3.3.4 for more information on first flush diverters.

#### ***Collection System***

As discussed previously, the rainwater harvesting system for the apartment building is designed in a manner similar to the system used in the residential scenario. Once again, Rainwater Harvester 2.0 (Jones 2010) is used to size the cisterns for each location. The cistern sizes are shown in Table 3.38.

**Table 3.38 Cistern Sizes by Location for the Apartment Building.**

City	Cistern Size	
	gal	l
Seattle	30,000	113,562
Scottsdale	50,000	189,270
Omaha	50,000	189,270
Tampa	50,000	189,270

From: (Gardels 2011)

The cistern is sized based on the rainfall patterns in the area and the demand for the rainwater within the building. Seattle requires less storage because it has a more uniform rainfall pattern throughout the year.

The size of the cistern is the limiting factor for the rainwater harvesting system. An inch (25.4 mm) of rain results in a volume of approximately 51,000 gallons (193,055 l) of water from the roof assuming 100% capture efficiency. Therefore, the rainwater collection system does not need to be designed to capture all of the rainwater from the roof, but only a maximum of 30,000 gallons (113,562 l) for Seattle and 50,000 gallons (189,270 l) for the other cities. As a result, an overflow system is needed to allow any excess water to bypass the rainwater harvesting system. Discussion of the overflow system is included later in this section.

After sizing the cistern, the individual catchment areas of the roof are delineated. The apartment roof has 26 sub-catchment areas. The collection area of each section is shown in Appendix B. Next, the gutter size and the number and diameter of downspouts are calculated using Table 3.13 and Table 3.14 for guidance.

To simplify gutter sizing and installation, the largest gutter diameter required for any catchment is used for the entire building. It is important to remember that the gutter

diameter listed assumes only one downspout for each collection area. Table 3.39 outlines the gutter and downspout requirements by city. The gutter diameter, number of downspouts, and downspout diameter are dependent on the size of the catchment area and the intensity of the rainfall. Roof diagrams giving the number of downspouts per catchment for each city are located in Appendix C.

**Table 3.39 Overview of Apartment Gutter and Downspout Requirements by City.**

City	100 yr 60 min Storm		Gutter Diameter		Number of Downspouts	Downspout Diameter	
	in/hr	mm/hr	in	mm		in	mm
Seattle	1.0	25.4	5	127.0	60	3	76.2
Scottsdale	2.2	55.88	6	152.4	62	3	76.2
Omaha	3.6	91.44	10	254.0	58	4	101.6
Tampa	4.2	106.68	10	254.0	60	4	101.6

Note: The rainfall intensity and catchment area determines the diameter of gutters and downspouts and the number of downspouts required.

As in the residential rainwater-harvesting scenario, first-flush diverters are also used in this scenario. Since the roof area of the apartment building is significantly larger than the house, the 12-inch (304.8 mm) diameter first flush diverters will be used. Using the 12-inch (304.8 mm) diameter first flush diverters reduces the number of diverters needed and the length of pipe required. The apartment will have four first flush diverters. The diverters are located on both sides of the main entrance on each side of the building. The locations of the first flush diverters are shown in Appendix D.

The roof has an area of 82,015 ft<sup>2</sup> (7,619.44 m<sup>2</sup>). Using the first-flush diversion rate of 0.01 gal/ft<sup>2</sup> (90.41 l/m<sup>2</sup>) (RainHarvest Systems 2010c), the amount of water that must be captured by the first-flush diverters is 820.15 gallons (3,104.6 l). From Table 3.10, the storage capacity 12 inch (304.8 mm) diameter Schedule 40 PVC pipe is 5.815

gal/ft (72.21 l/m). Therefore, a total of 141 feet (42.98 m) of 12 inch (304.8 mm) diameter PVC pipe is required to capture the required first-flush volume. This length is divided between the four subcatchments based on the ratio of their area to the total area. The subcatchments inside of the “U” of the apartment each contribute 23% of the total roof area, whereas each outside subcatchment contributes 27%. Therefore, the length of pipe needed to capture the first-flush from each inside subcatchment is 32.5 feet (9.91 m) and the length required for each of the outside subcatchments is 38 feet (11.58 m).

Next, the underground collection system is sized. The downspouts will go underground and connect to the main collection pipe that is 6 feet (1.83 m) away from the building. Placing the pipe 6 feet (1.83 m) away from the building ensures that the pipe will not go under patios and allows clearance from the building to prevent any potential water problems.

The National Standard Plumbing Code (2006) states that primary drainage systems such as this one should be sized to accommodate a 60-minute, 100-year return period storm. However, in this scenario, the cisterns can only accommodate a specific volume. This constraint creates two different design scenarios. The first option is to design the horizontal pipes to carry the flow of a 60-minute duration and 100-year return period storm to the cistern and have an overflow valve for the excess water to exit the system once the cistern is full. The second option is to design the horizontal collection system to collect enough water to fill this cistern, and have outlets throughout the system to discharge excess water. In the apartment scenario, the second option is utilized, as it requires smaller pipe diameters and therefore lower costs.



The collection pipes that run along the outside of the building are 6-inch (152.4 mm) diameter schedule 40 PVC pipe. Water collected from the inside of the apartment complex runs under the apartment building through a basement area to the cistern on the outside of the building. The two collection pipes connecting to the cistern are 8-inch (203.2 mm) diameter schedule 40 PVC pipe. Figure 3.18 shows the layout of the horizontal collection system for the apartment.

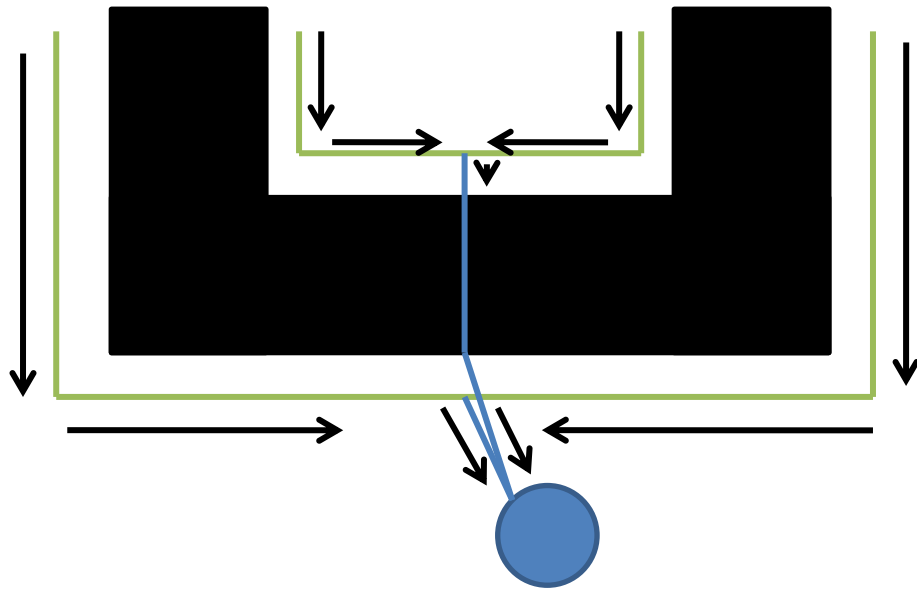

**Figure 3.18 Horizontal Rainwater Collection System for Apartment Building.** The blue lines represent 6-inch (152.4 mm) diameter PVC pipe while the blue lines represent 8-inch (203.2 mm) diameter PVC pipe.

Since the horizontal pipes are not sized to carry the required 60-minute duration and 100-year return period storm, risers are required along the distribution system to discharge excess water. Once the cistern is full, water will begin discharging through the overflow located at the cistern, as well as through the risers once the head in the pipes is greater than the height of the risers. With this system, the flow from the required design storm is carried away from the building to prevent water damage even though the

collection pipes are not designed to handle the entire flow. The advantage is that smaller diameter pipes can be used in the collection system to transport water to the cistern.

### ***Additional Infrastructure Required***

Gutters are not considered extra infrastructure in this analysis as gutters are required whether rainwater harvesting is occurring or not. Changes to the gutter system such as increasing the diameter and adding gutter screens can improve the system for more beneficial rainwater harvesting but they are not required. Table 3.40 through Table 3.44 list additional materials required for the rainwater harvesting system.

**Table 3.40 Materials Required for Apartment Rainwater Harvesting System in All Study Cities**

<b>Material</b>	<b>Amount</b>
6 inch (152.4 mm) Schedule 40 PVC Pipe (collection from downspouts)	1919 ft (584.91 m)
8 inch (203.2 mm) Schedule 40 PVC Pipe (conveyance to cistern)	116 ft (35.36 m)
6 inch (152.4 mm) to 8 (203.2) inch Pipe Expanders (expanding collection pipe diameter to conveyance pipe diameter)	4
8 inch (203.2 mm) PVC Tees (connecting collection system to conveyance system)	2
6 inch (152.4 mm) 90 degree PVC Elbows (turn pipe around corners of building)	4
6 inch (152.4 mm) Schedule 40 PVC Pipe (cistern overflow)	10 ft (3.05 m)
6 inch (152.4 mm) Schedule 40 PVC Pipe (overflow risers)	81 ft (24.69 m)
6 inch (152.4 mm) PVC Tees (connect overflow risers to horizontal pipe)	28
6 inch (152.4 mm) PVC Long Radius Elbows (for top of overflow risers to prevent debris from entering)	28
First-Flush Diverter Unit for 12 inch (304.8 mm) PVC Pipe	4
12 inch (304.8 mm) Schedule 40 PVC Pipe (collection pipe for first flush diverters)	141 ft (42.98 m)

**Table 3.41 Additional Apartment Outdoor Plumbing Materials Required for Seattle**

<b>Materials</b>	<b>Amount</b>
Downspout filters	60
3 inch (76.2 mm) PVC 45 degree Elbows (connect downspouts to horizontal pipes)	60
3 inch (76.2 mm) Schedule 40 PVC Pipe (vertical pipe needed to connect downspouts to horizontal pipe)	105 ft (32.0 m)
3 inch (76.2 mm) Schedule 40 PVC Pipe (horizontal pipe needed to connect downspouts to horizontal pipe)	360 ft (109.73 m)
3 inch (76.2 mm) to 6 inch (152.4 mm) PVC Pipe Expanders	56
6 inch(152.4 mm) Tees (horizontal pipe from downspout to main horizontal pipe)	56
3 inch (76.2 mm) to 6 inch (152.4 mm) Pipe Expanders (connect end apartments to main drainage system)	4
6 inch (152.4 mm) 90 degree Elbows (connect end apartments to main drainage system)	4

**Table 3.42 Additional Apartment Outdoor Plumbing Materials for Scottsdale**

<b>Materials</b>	<b>Amount</b>
Downspout filters	62
3 inch (76.2 mm)PVC 45 degree Elbows (connect downspouts to horizontal pipes)	62
3 inch (76.2 mm) Schedule 40 PVC Pipe (vertical pipe needed to connect downspouts to horizontal pipe)	108 ft (32.92 m)
3 inch (76.2 mm) Schedule 40 PVC Pipe (horizontal pipe needed to connect downspouts to horizontal pipe)	372 ft (113.39 m)
3 inch (76.2 mm) to 6 inch (152.4 mm) PVC Pipe Expanders	58
6 inch (76.2 mm) PVC Tees (horizontal pipe from downspout to main horizontal pipe)	58
3 inch (76.2 mm) to 6 inch (152.4 mm) Pipe Expanders (connect end apartments to main drainage system)	4
6 inch (152.4 mm) 90 degree Elbows (connect end apartments to main drainage system)	4

**Table 3.43 Additional Apartment Plumbing Materials for Omaha**

<b>Materials</b>	<b>Amount</b>
Downspout filters	58
3 inch (76.2 mm) Schedule 40 PVC 45 degree Elbows (connect downspouts to horizontal pipes)	58
3 inch (76.2 mm) Schedule 40 PVC Pipe (vertical pipe needed to connect downspouts to horizontal pipe)	100 ft (30.48 m)
3 inch (76.2 mm) Schedule 40 PVC Pipe (horizontal pipe needed to connect downspouts to horizontal pipe)	348 ft (106.07 m)
3 inch (76.2 mm) to 6 inch (152.4 mm) PVC Pipe Expanders	54
6 inch (152.4 mm) Schedule 40 PVC Tees (horizontal pipe from downspout to main horizontal pipe)	54
3 inch (76.2 mm) to 6 inch (152.4 mm) Schedule 40 PVC Pipe Expanders (connect end apartments to main drainage system)	4
6 inch (152.4 mm) Schedule 40 PVC 90 degree Elbows (connect end apartments to main drainage system)	4

**Table 3.44 Additional Apartment Plumbing Materials for Tampa**

<b>Materials</b>	<b>Amount</b>
Downspout filters	60
3 inch (76.2 mm) Schedule 40 PVC 45 degree Elbows (connect downspouts to horizontal pipes)	60
3 inch (76.2 mm) Schedule 40 PVC Pipe (vertical pipe needed to connect downspouts to horizontal pipe)	105 ft (32.0 m)
3 inch (76.2 mm) Schedule 40 PVC Pipe (horizontal pipe needed to connect downspouts to horizontal pipe)	360 ft (109.73 m)
3 inch (76.2 mm) to 6 inch (152.4 mm) Schedule 40 PVC Pipe Expanders	56
6 inch (152.4 mm) Schedule 40 PVC Tees (horizontal pipe from downspout to main horizontal pipe)	56
3 inch (76.2 mm) to 6 inch (152.4 mm) Schedule 40 PVC Pipe Expanders (connect end apartments to main drainage system)	4
6 inch (152.4 mm) Schedule 40 PVC 90 degree Elbows (connect end apartments to main drainage system)	4

### 3.4.2 EPANET 2 Model for Apartment Building

The model for the apartment building was created using EPANET 2. In this model, the plumbing fixtures of interest are toilets and clothes washers because they are the rainwater consumers. Water enters the system via the rainwater harvesting system described previously. From the rainwater cistern, a 10 horsepower (7457 watt) pump

delivers water to a 22-gallon (83.28 l) pressure tank. From the pressure tank, the water is distributed to each floor by 3-inch (76.2 mm) PVC pipe.

Once the water is distributed to each floor, the pipe diameter is reduced to 2, 2-inch (50.8 mm) diameter branches. The 2-inch (50.8 mm) diameter PVC pipe transports the water down the hallways and to the manifold in each apartment. From the manifold, the water is delivered to the toilet(s) and clothes washer in the apartment via ½-inch (12.7 mm) diameter PEX. A Hazen-Williams coefficient of 147 is used for PVC (Lamont 1981). The minor loss coefficients used in the model are in Table 3.4. The Hazen-Williams coefficient used for PEX is 150 (Plastics Pipe Institute 2000).

A flow control valve (FCV) is used to simulate flow demands in each apartment. The simple controls editor in EPANET 2 is used to turn the valves on and off throughout the simulation. A flow of 1.3 gpm (4.92 lpm) for 1 minute represents a toilet flush and a flow of 5 gpm (18.93 lpm) for 3 minutes signifies the clothes washer being used. The number of toilet flushes and clothes washer cycles per capita per day are 5.05 and 0.37, respectively as found in Table 3.1 (Mayer et al. 1999). The EPANET 2 layout for one floor of the apartment building is shown in Figure 3.19.

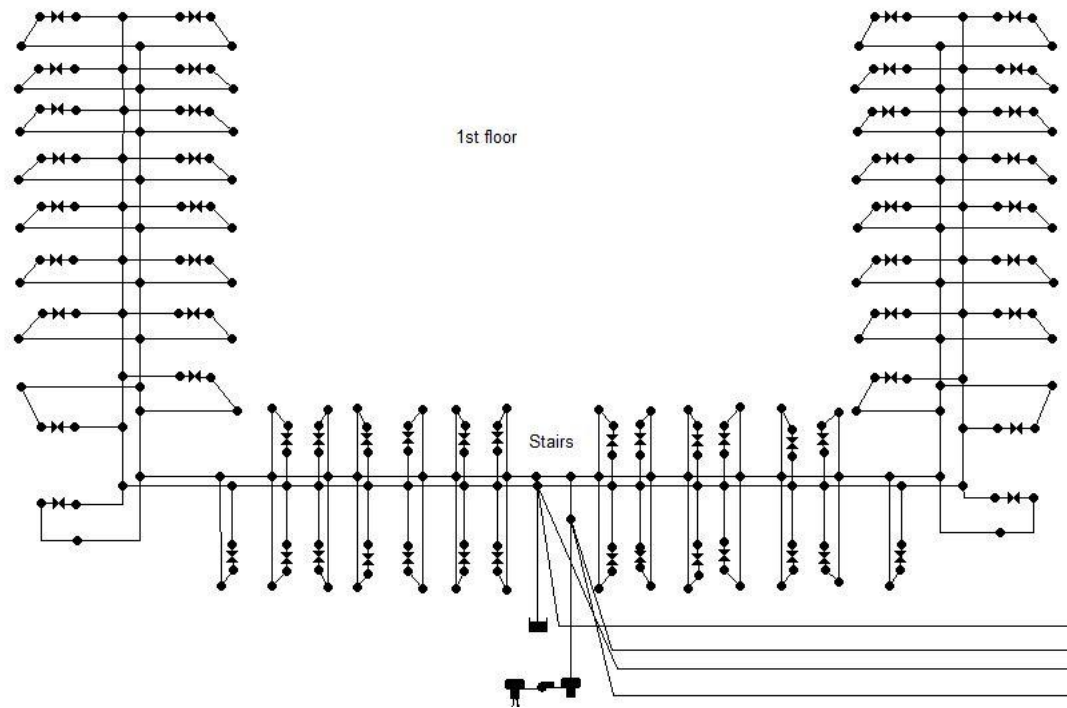

**Figure 3.19 EPANET 2 Layout for One Floor of the Apartment Building**

The assumptions made for the outdoor rainwater harvesting system are also checked using EPANET 2. As mentioned previously in the *Collection System* section, the horizontal pipes cannot handle the required 100-year return period, 60-minute duration design storm. As a result, risers were attached to the drainage system to ensure the water does not back up onto the roof. The layout for the rainwater harvesting system is in Figure 3.20.

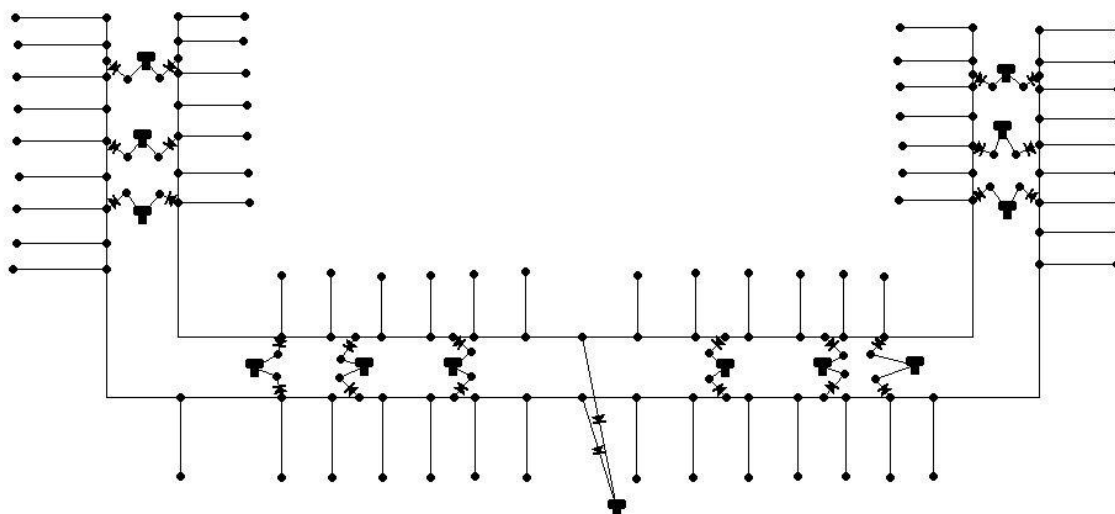

**Figure 3.20 Layout of Collection System for Apartment Rainwater Harvesting**

The nodes at the ends of the pipes represent individual catchment areas on the roof. The pipes represent the downspouts, and the pipes connecting the downspouts are the underground collection system. The tanks in the figure are the sinks for the overflow system. Running the system in EPANET 2 shows that the overflow system adequately removes the excess water from the collection system ensuring that water does not back up on the roof.

The files for the indoor infrastructure for rainwater distribution and the outdoor rainwater harvesting system as well as directions for how to run the models are in Appendix A.

#### ***Additional Indoor Infrastructure Required***

When compared to a traditional plumbing system, the additional indoor infrastructure required for the apartment building is listed in Table 3.45. The PEX from the manifold to the toilet(s) and clothes washer is not included because it is required in the conventional plumbing system.

**Table 3.45 Additional Indoor Infrastructure for Apartment Building**

<b>Material</b>	<b>Amount</b>
PEX Manifold (2 in (50.8 mm) inflow to 2, ½ in (12.7 mm) outflows)	72
PEX Manifold (2 in (50.8 mm) inflow to 3, ½ in (12.7 mm) outflows)	108
2 in (50.8 mm) Schedule 40 PVC Pipe (down the hallways on each floor)	5163 ft (1573.68 m)
2 in (50.8 mm) Schedule 40 PVC Tees (branch to each apartment)	174
3 in (76.2 mm) to 2 in (50.8 mm) Schedule 40 PVC Pipe Reducers (reducer for each hallway branch)	6
3 in (76.2 mm) Schedule 40 PVC Tees (distribute water to each floor)	5
3 in (76.2 mm) Schedule 40 PVC 90 degree Elbows (distribute water to each floor)	8
3 in (76.2 mm) Schedule 40 PVC Pipe (pipe from cistern to pump and to each floor)	93.9 ft (28.6 m)
1 in (25.4 mm) Schedule 40 PVC Pipe (potable backup line)	52.9 ft (16.12 m)
10 HP (7457 watt) Grundfos Pump 230S150-5B	1
22 gallon (83.28 l) Flex-Lite Pressure Tank	1

### 3.4.3 Rainwater Benefits

In the apartment building scenario, the rainwater is used for toilet flushing and clothes washing. The main benefit of using rainwater harvesting is the reduction in the potable water demand and the associated costs. One drawback to rainwater harvesting is the need to keep the roof clean of debris during dry periods to achieve the highest quality rainwater possible.

### 3.5 Community Scale

Conventional water distribution systems in a community have one pipe network to deliver water to houses and businesses and to meet the fire flow requirements. An alternative to the conventional system is a dual distribution system. In a dual distribution system, two separate pipe networks are utilized to meet the residential, commercial, and fire flow demands. The reclaimed water system, uses reclaimed water, or highly treated wastewater, to meet non-potable demands such as irrigation, toilet flushing, and fire flow. The reclaimed system typically has pipe diameters similar to the conventional system.



The other pipe network in a dual distribution system is for potable water. The potable water system has smaller pipe diameters and delivers potable water for human consumption.

In the community scale model, wastewater is collected from residences and businesses and treated within the community. The wastewater is treated to the reclaimed water standards listed in Table 2.8, and then it is distributed back to the community through a reclaimed water supply system. The reclaimed water will be used for fire flow, landscape irrigation, toilet flushing, and clothes washing. The uses are categorized as unrestricted urban use and, therefore, the reclaimed water must meet the standards outlined in Table 2.8. The goal of the community system is to reduce the potable water demand, thereby reducing the associated energy and treatment costs as well as reducing the freshwater withdrawal volume.

### **3.5.1 Definition of Typical Community**

For this project, the definition of the typical community is based upon a square mile (2.6 km<sup>2</sup>) development in a local city. The community includes businesses, apartments, and single-family homes. The breakdown of building types is given in Table 3.46.

**Table 3.46 Breakdown of Buildings in the Community Scenario**

<b>Building Type</b>	<b>Number</b>
Apartment Complexes	4
Bank	1
Church	1
Drug Store	1
Fast Food Restaurants	3
Full Service Restaurants	4
Hotel	1
Large Office Building	1
Medical Offices	3
Outlet Stores	14
School	1
Service Station	1
Single Family Homes	1199
Spa	1
Supermarket	1

The majority of the development consists of single-family homes. Businesses are located in the northwest and southwest corners of the development, and a school is centrally located within the neighborhood. Apartment buildings are scattered among the businesses on the west side of the development and are also located in the northeast corner. In addition, a stream flows through the southwest portion of the development. A satellite image of the area is shown in Figure 3.21.



From: (Google 2010)

**Figure 3.21 Satellite View of the Neighborhood Used in the Community Scenario**

### **3.5.2 Determining Community Water Demands**

Multiple procedures are used in determining the water demand for the community. The demand for single-family homes and apartment buildings are found in the same manner as used for the individual residences discussed previously. The demands for the non-residential buildings are determined using estimates based on the building type.

#### ***Demands for Single-Family Homes in Community***

The typical single-family home is assumed to be two floors with a total living area of 2,550 ft<sup>2</sup> (236.90 m<sup>2</sup>) and a garage area of 525 ft<sup>2</sup> (48.77 m<sup>2</sup>). The average residence is

assumed to have 2.8 occupants (Mayer et al. 1999). For the single-family homes, the per capita demands given in Table 3.3 are used to determine the average potable and average non-potable demands as well as the average wastewater production. A peaking factor of 1.8 is applied to the average demands to determine the peak day demand (Gupta 2008). A demand pattern is also applied to simulate the diurnal pattern of residential water demand (AWWARF 1993). A peaking factor for the peak hour is not used because it is embedded in the demand pattern used. The residential demand pattern is located in Appendix E For the dual distribution system, the potable and non-potable demands were separated.

The potable indoor demands include the kitchen and bathroom faucets, shower and dishwasher. For a single-family residence during an average day, the potable demand is 78 gpd (295.26 lpd). A peaking factor of 1.8 is used to determine the peak day flow rate of 140.4 gpd (531.47 lpd) (Gupta 2008).

The non-potable indoor demands include the toilets and clothes washer. For a typical single-family home, the indoor non-potable demand is 34 gpd (128.70 lpd). The peaking factor of 1.8 is applied to the average demand to determine the peak demand of 61.2 gpd (231.67 lpd) (Gupta 2008). The average wastewater production from a typical single-family home is 112 gpd (423.97 lpd). When the peaking factor of 1.8 is applied, the peak flow rate is 201.6 gpd (763.14 lpd) (Gupta 2008). Residential fire and irrigation demands are also taken into consideration. Fire demand requirements are discussed later in this section. The most important factor regarding irrigation is the required flow rate. The average flow rate for an outdoor faucet is 12 gpm (45.42 lpm) (Moen 2010). This value is assumed to represent the irrigation demand for one house.

### *Demands for Apartments in the Community*

The community has four apartment complexes. The occupancy and square footage are outlined in Table 3.47. The average and peak water demands for the apartment buildings are given in Table 3.48. The average demands for the apartment are determined using the per capita values in Table 3.3 multiplied by the total occupancy for the apartment. The peak demand is found by multiplying the average demand by a peaking factor of 1.8 (Gupta 2008). The same diurnal demand pattern used for the single-family homes is applied to the apartments. The apartment complexes utilize the same irrigation flow rate as the houses (12 gpm, 45.42 lpm).

**Table 3.47 Overview of Apartment Complexes in Community Scenario**

Apartment Number in Model	Number of Buildings	Occupants per Building	Total Occupants	Total Building Square Footage	
				ft <sup>2</sup>	m <sup>2</sup>
1	7	75	525	29600	2749.93
2	6	75	450	44100	4097.02
3	1	1200	1200	251000	23318.70
4	8	150	1200	31400	2917.15

**Table 3.48 Apartment Complex Water Demands**

Apartment Number in Model	Average Potable Water Demand		Average Non-potable Water Demand		Peak Potable Water Demand		Peak Non-potable Water Demand	
	gpm	lpm	gpm	lpm	gpm	lpm	gpm	lpm
1	10.15	38.42	4.40	16.66	18.27	69.16	7.92	29.98
2	8.70	32.93	3.77	14.27	15.66	59.28	6.79	25.70
3	23.20	87.82	10.05	38.04	41.76	158.08	18.09	68.48
4	23.20	87.82	10.05	38.04	41.76	158.08	18.09	68.48

### *Demands for Non-Residential Buildings*

Published demand estimates were used for the non-residential buildings. The demand estimates and associated assumptions are outlined in Table 3.49.

**Table 3.49 Non-Residential Water Demands for Community Scenario.**

Building Type	Unit	Demand per Unit		Assumed Number of Units	Average Demand	
		gpd	lpd		gpd	lpd
Bank	Employee	25	95	100	2500	9464
Church	Employee	25	95	30	750	2839
Dentist Office	Employee	25	95	30	750	2839
Doctor's Office	Employee	25	95	30	750	2839
Drug Store	Employee	25	95	30	750	2839
Fast Food Restaurants	Seats	35	132	80	2800	105999
Full Service Restaurants	Seats	35	132	100	3500	13249
Hotel	Room	100	379	80	8000	30283
Large Office Building	Employee	25	95	200	5000	18927
Outlet Stores	Employee	25	95	70	1750	6624
School	Student	15	57	880	13200	49967
Service Station	Bay/Pump Island	1000 gpd (3785 l/d) for first bay or pump island 500 gpd (1893 l/d) per additional bay/pump island		3	2000	7571
Spa	Customer	100	379	10	1000	3785
Supermarket	Seats*	35	132	200	7000	26498
Urgent Care Office	Employee	25	95	30	750	2839

\*Values for a supermarket were not given, therefore, the supermarket is assumed to be similar to a restaurant with 200 seats.

Adapted from: (Viessman and Hammer 1998; North Carolina Environmental Management Commission 2001; Ameen 1971)

The breakdown of the demand between potable and non-potable is given in Table 3.50. A peaking factor of 1.5 is used to determine the peak flows listed in Table 3.51. A peaking factor of 1.5 is used to represent the hour of the highest demand on the peak day (Gupta 2008). A peak day factor is not used because the non-residential buildings are assumed to have a consistent demand throughout the year. The main contributing factor

in determining the peak day is irrigation. Therefore, irrigation at the non-residential buildings is assumed to be minor.

**Table 3.50 Breakdown of Non-Residential Demands to Potable and Non-potable Demands**

Non-Residential Building	Percent Potable Water	Percent Non-potable Water	Average Potable Demand		Average Non-potable Demand	
			gpm	lpm	gpm	lpm
Bank	10	90	0.17	0.64	1.56	5.91
Church	10	90	0.05	0.19	0.47	1.78
Dentist Office	10	90	0.05	0.19	0.47	1.78
Doctor's Office	10	90	0.05	0.19	0.47	1.78
Drug Store	10	90	0.05	0.19	0.47	1.78
Fast Food Restaurant	55	45	1.07	4.05	0.87	3.29
Hotel	55	45	3.05	11.55	2.50	9.46
Large Office Building	10	90	0.35	1.32	2.81	10.64
Outlet Stores	10	90	0.12	0.45	1.09	4.13
Restaurant	55	45	1.33	5.03	1.09	4.13
School	15	85	1.37	5.19	7.79	29.49
Service Station	10	90	1.39	5.26	1.25	4.73
Spa	55	45	0.39	1.48	0.31	1.17
Supermarket	10	90	0.49	1.85	4.37	16.54
Urgent Care Office	10	90	0.05	0.19	0.47	1.78

Adapted from: (North Carolina Department of Environment and Natural Resources 2009)

**Table 3.51 Peak flow rates for Non-Residential Buildings in Community**

Non-Residential Building	Peak Potable Demand		Peak Non-potable Demand	
	gpm	lpm	gpm	lpm
Bank	0.26	0.98	2.34	8.86
Church	0.08	0.30	0.70	2.65
Dentist Office	0.08	0.30	0.70	2.65
Doctor's Office	0.08	0.30	0.70	2.65
Drug Store	0.08	0.30	0.70	2.65
Fast Food Restaurant	1.60	6.06	1.31	4.96
Hotel	4.58	17.34	3.75	14.20
Large Office Building	0.52	1.97	4.22	15.97
Outlet Stores	0.18	0.68	1.64	6.21
Restaurant	2.00	7.57	1.64	6.21
School	2.06	7.80	11.69	44.25
Service Station	2.08	7.87	1.88	7.12
Spa	0.58	2.20	0.47	1.78
Supermarket	0.73	2.76	6.56	24.83
Urgent Care Office	0.08	0.30	0.70	2.65

**Water Demands in EPANET 2**

The demands calculated above must be integrated into the EPANET 2 model.

First, houses were assigned to each node. The maximum number of houses allowed at one node is ten. Apartment complexes and non-residential buildings are each assigned to their own node.

For the single-family homes, the base water demand is determined by multiplying the number of houses at the node by 0.1. For example, a node with ten houses has a base demand of 1 gpm (3.79 lpm) and a node with six houses has a base demand of 0.6 gpm (2.27 lpm). Then, the residential demand pattern, presented in Appendix E is converted to a pattern in EPANET. Patterns are created in EPANET by using multipliers that are applied to the base demand for given time increments through the day.



The multiplier used in the patterns is determined by multiplying the hourly percentage of total use given in Appendix E, by the peak demand for a 10-house node and then dividing by 100. The end result is the hourly flow rate in gallons per hour for a 10-house node. The flow rate is converted to gallons per minute to align with the model unit requirements. An example calculation for the peak conventional demand for 9:00-10:00 am is given below.

**Example:**

The hourly percentage of total daily use (from Appendix E) for 9:00 AM to 10:00 AM is 6%. The peak daily demand for a 10-house node is 2111 gal (7991 l). Therefore, the actual water use rate for a 10-house node between 9:00 AM and 10:00 AM is 120.7 gal/hr (2.0 gpm).

$$\frac{0.06}{hr} \times 2111 \text{ gal} = \frac{120.7 \text{ gal}}{hr} = \frac{2.0 \text{ gal}}{min}$$

A value of 2.0 is the EPANET multiplier for hour 10 in the EPANET residential pattern editor. Therefore, the actual demand at a node with ten houses (base demand of 1 gpm, 3.79 l) between 9:00 and 10:00 AM is 2 gpm (base demand multiplied by EPANET multiplier). For a node with six houses, the actual demand during this time is 1.2 gpm (4.54 lpm) (base demand of 0.6 gpm (2.27 lpm) multiplied by the pattern multiplier of 2). The EPANET multipliers used for the community models are given in Appendix F.

. The apartment complexes utilize the same pattern as the single-family homes. Therefore, a ratio between the occupancy at a 10-house node, which the pattern multipliers are designed for, and the occupancy of each apartment building is needed. The base demand for the apartments is determined by dividing the total occupancy listed in Table 3.47 by 28 (the number of people per 10 house node) and multiplying by 1 gpm

(3.79 lpm) (the base demand at a 10 house node). For an apartment with 525 occupants, the base demand is 18.75 gpm (70.98 lpm) ( $525/28 * 1 \text{ gpm} = 18.75 \text{ gpm}$ ).

The non-residential demand is assumed to not change throughout the day because no demand patterns were found in the literature. As a result, the EPANET pattern has a multiplier of one for the entire day. This results in the peak day flow being distributed over the entire day. This likely overestimates the actual demand and results in a conservative infrastructure design.

### ***Fire Demand***

The community reclaimed water distribution system is responsible for supplying water to meet the required fire demand. Flow requirements for fire demand are established based on the type of building materials, size of the building, and the presence or absence of fire sprinklers.

For this model, the building area is determined using Google Earth (Google 2010). The total square footage for each building in the community as well as the required fire flow associated with the building is given in Table 3.52. All buildings except for the single-family homes are equipped with a fire sprinkler system.

**Table 3.52 Square Footage of Buildings in Community and Required Fire Flow Rates.**

Building	Area		Fire Flow Requirement w/o sprinklers (Flow Duration, hr)		Fire Flow Requirement with sprinklers (2 hr duration)	
	ft <sup>2</sup>	m <sup>2</sup>	gpm	lpm	gpm	lpm
Apartments 1 (7 buildings)	29600 (per building)	2749.93	3750 (3)	14195 (3)	1500	5678
Apartments 2 (6 buildings)	44100 (per building)	4097.02	4500 (4)	17034 (4)	1500	5678
Apartments 3 (1 building)	251000	23318.70	3750 (3)	14195 (3)	1500	5678
Apartments 4 (8 buildings)	31400 (per building)	2917.15	8000 (4)	30283 (4)	2400	9085
Bank	32800	3047.22	3750 (3)	1419 (3)	1500	5678
Church	14300	1328.51	2500 (2)	9464 (2)	1500	5678
Dentist Office	4900	455.23	1500 (2)	5678 (2)	1500	5678
Doctor's Office	16300	1514.32	2750 (2)	10410 (2)	1500	5678
Drug Store	14000	1300.64	2500 (2)	9464 (2)	1500	5678
Fast Food Restaurant 1	4000	371.61	1500 (2)	5678 (2)	1500	5678
Fast Food Restaurant 2	6400	594.58	2000 (2)	7571 (2)	1500	5678
Fast Food Restaurant 3	9300	864.00	2000 (2)	7571 (2)	1500	5678
Hotel	46600	4329.28	4500 (4)	17034 (4)	1500	5678
Large Office Building	59300	5509.15	5250 (4)	19873 (4)	1500	5678
Outlet Stores	61900	5750.70	5250 (4)	19873 (4)	1500	5678
Restaurant 1	11700	1086.97	2500 (2)	9464 (2)	1500	5678
Restaurant 2	11400	1059.09	2250 (2)	8517 (2)	1500	5678
Restaurant 3	11400	1059.09	2250 (2)	8517 (2)	1500	5678
Restaurant 4	6000	557.42	1750 (2)	6624 (2)	1500	5678
School	159000	14771.60	8000 (4)	30283 (4)	2400	9085
Service Station	4600	427.35	1500 (2)	5678 (2)	1500	5678
Single-Family Home (2 levels)	3075	285.68	1500 (2)	5678 (2)	1500	5678
Spa	6800	631.74	1750 (2)	6624 (2)	1500	5678
Supermarket	51900	4821.67	4750 (4)	17981 (4)	1500	5678
Urgent Care Office	4900	455.23	1500 (2)	5678 (2)	1500	5678

Adapted from: (National Fire Protection Association 2006)

The building material for all of the commercial buildings is assumed to be a non-combustible exterior and a combustible interior. The interior construction is assumed to be mostly wood. This is the III-N rating used by the National Fire Protection Association.

The houses are assumed to have a combustible exterior and interior. This corresponds to the V-N category in the Uniform Fire Code Handbook (National Fire Protection Association 2006). The N in the rating stands for no fire rating meaning a fire rating has not been assigned to the building material.

As shown in Table 3.52, the use of fire sprinklers can reduce the fire flow requirement. Fire sprinklers can reduce the fire flow requirements up to 75% in non-residential buildings, but the flow cannot be reduced to less than 1500 gpm (5678 lpm) (National Fire Protection Association 2006). Fire sprinklers are not used in the single-family homes.

The water infrastructure must also be capable of handling the required flows and maintain a minimum pressure of 20 psi (138 kpa) at all times. The design constraints for fire flow results in a minimum pipe diameter of 6-inches (Hammer and Hammer 2008; AWWA 2008).

### **Fire Demand in EPANET 2**

Fires in EPANET are simulated using a pattern with a base demand of 1 gpm (3.79 lpm). The multiplier for the pattern is 0 except for two hours during the day when the demand changes to 1500 or 2400 gpm (5678 or 9085 lpm) depending on the location of the fire.

### **3.5.3 Conventional Distribution System**

The conventional distribution system delivers water for both potable and non-potable uses including fire flow. All water in the system is treated to drinking water standards. The peak flow rates listed in the preceding tables are used to design the

community water systems. Designing for peak flows ensures the system will be able to deliver the maximum demand and fire flow simultaneously.

### ***EPANET 2***

The basic pipe network for a neighborhood was obtained from a local water utility. The pipe network was created in EPANET 2. The neighborhood was then isolated from other neighborhoods to serve as a stand-alone community in this analysis. In the conventional distribution system, water is treated outside of the community. The water is then pumped into the community and stored in elevated storage. The goal of isolating the neighborhood from the surrounding neighborhoods and including a pump and storage is to allow easy comparison between the conventional, non-potable, and potable models. The pipe network for the conventional system is shown in Figure 3.22.

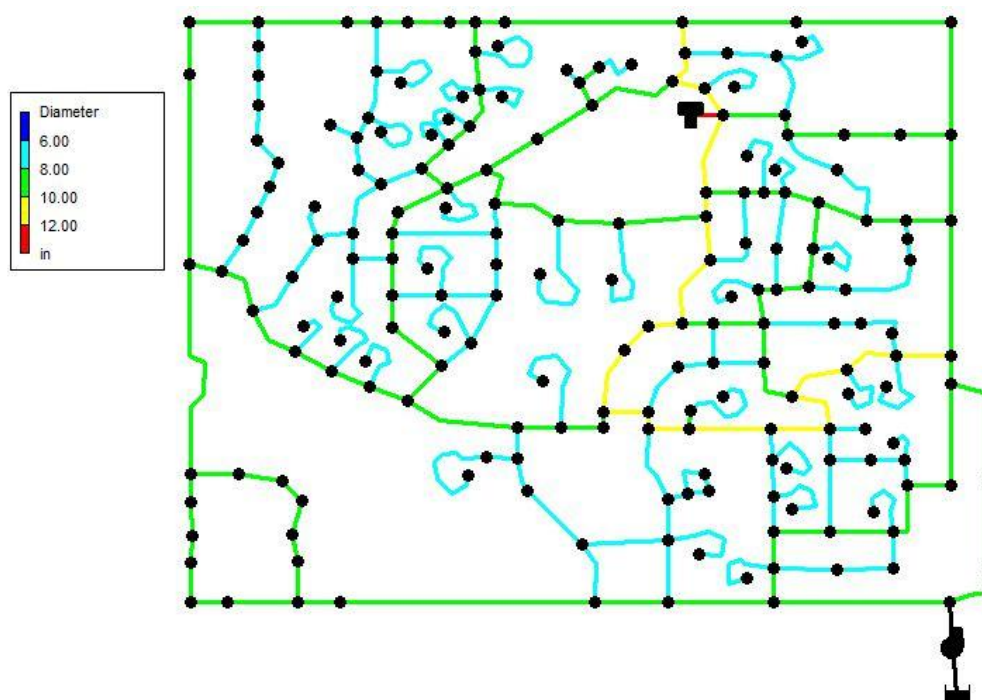

**Figure 3.22 Pipe Network for Conventional Community Model Showing Pipe Diameters**

A Hazen-Williams coefficient of 130 is used for the pipe network (AWWA 2004). The minor loss coefficients used in the model are in Table 3.4.

The elevated storage tank (upper-right quadrant) is designed to store the peak day plus fire flow for a total volume of 1.29 million gallons (4.88 million liters). During the peak day, irrigation occurs at each residential node for two hours in the morning and two hours in the afternoon. The irrigation demand for each node is 12 gpm (45.42 lpm). The demand of 12 gpm (45.42 lpm) represents one house irrigating at each node during the irrigation period.

Once the piping network is sized to meet the peak demands and fire flow, the demands are modified to represent an average day. To determine the average daily water use and the pumping energy, irrigation is reduced by 40%, and the average demands mentioned previously are used. The average irrigation demand is assumed to be 40% of the peak flow. From the results of the model in EPANET, the average daily water use is 579,000 gallons (2.19 million liters) and the pumping energy is 831 Kw-hr/Mgal (0.00022 Kw-hr/MI). A Grundfos 800S750-3A pump is used in the conventional model to deliver water from the treatment plant (lower-right corner) to the distribution system.

The system is designed such that the pump turns on anytime the system demand is greater than 1500 gpm (5678 lpm) or when the water level in the tank drops below 20 ft (6.10 m). The water level is not allowed to drop below 20 ft (6.10 m) because it corresponds to the volume needed for a fire requiring the highest flow rate of 2400 gpm (9085 lpm) for 2 hours.

Using the water quality function of EPANET 2, the age of the water in elevated storage is 100 hours during peak flow conditions without fire flow and 117 hours during average day conditions. The age of water in a distribution system is a major component of water quality degradation. Water quality issues associated with water age are disinfection by-product formation, loss of residual disinfectant, taste and odor issues, microbial regrowth, and deposition of sediments to name a few. The average water age in municipal systems is reported to be from 1.3 to 3.0 days. Water age is dependent on the water demand, system design, and system operation. The lower the water age the better the water quality is in a system (USEPA 2002).

The file for the conventional community system is below. Directions for how to run the model are located in Appendix A.

#### **3.5.4 Reclaimed Distribution System**

The reclaimed distribution system for the community is designed to meet the non-potable needs including toilet flushing, clothes washing, irrigation, and fire demand. The water is treated to the unrestricted reclaimed water standards outlined in Table 2.8. The system is designed based on the peak flow rates outlined in Section 3.5.2.

In the reclaimed system, the wastewater from the community is treated to reclaimed standards within the community. Once the water is treated, it is redistributed to the community in the reclaimed pipe network of the dual distribution system.

One potential concern with the reclaimed distribution system is the recirculation and/or buildup of contaminants in the water. To meet the indoor reclaimed water needs (toilet flushing and laundry) approximately 40% of the total wastewater produced in the

community is needed. The remaining 60% of the wastewater could be used for lawn irrigation after treatment or discharged to a stream.

During the irrigation system, the wastewater produced in the community is unlikely to meet the higher reclaimed water demand. Therefore, stormwater collected in the neighboring pond or a backup potable supply line is needed to compensate for the difference between reclaimed water production and reclaimed water demand. An additional option to help meet the irrigation demand is to install rainwater harvesting systems at the individual residences and businesses. Using harvested rainwater will help reduce the irrigation demand. Another option is to decrease the irrigation demand by planting vegetation that requires minimal irrigation.

### ***EPANET 2***

The same pipe layout is used as in the conventional model with the exception of the pump location. The demands were adjusted in EPANET to reflect only the non-potable demands. Then, the network was inspected to see if any pipe diameters could be decreased. The criteria for determining if a pipe diameter can be decreased are based on the pipe velocity and node pressures. The typical design velocity for pipe is 5 ft/s (1.52 m/s) (Hammer and Hammer 2008; Viessman and Hammer 1998). The maximum pressure in a system is 90-110 psi (620.5-758.4 kpa) and the minimum pressures are between 40-50 psi (275.8-344.7 kpa) (Viessman and Hammer 1998). The results of this analysis showed that the same pipe diameters are required for both the conventional and reclaimed models. This is not too surprising because the only difference between the two systems is the potable water demand, which is negligible when compared to the flow rates required



for irrigation and fire flow. The pipe layout and pipe diameters are the same as the conventional system shown in Figure 3.23.

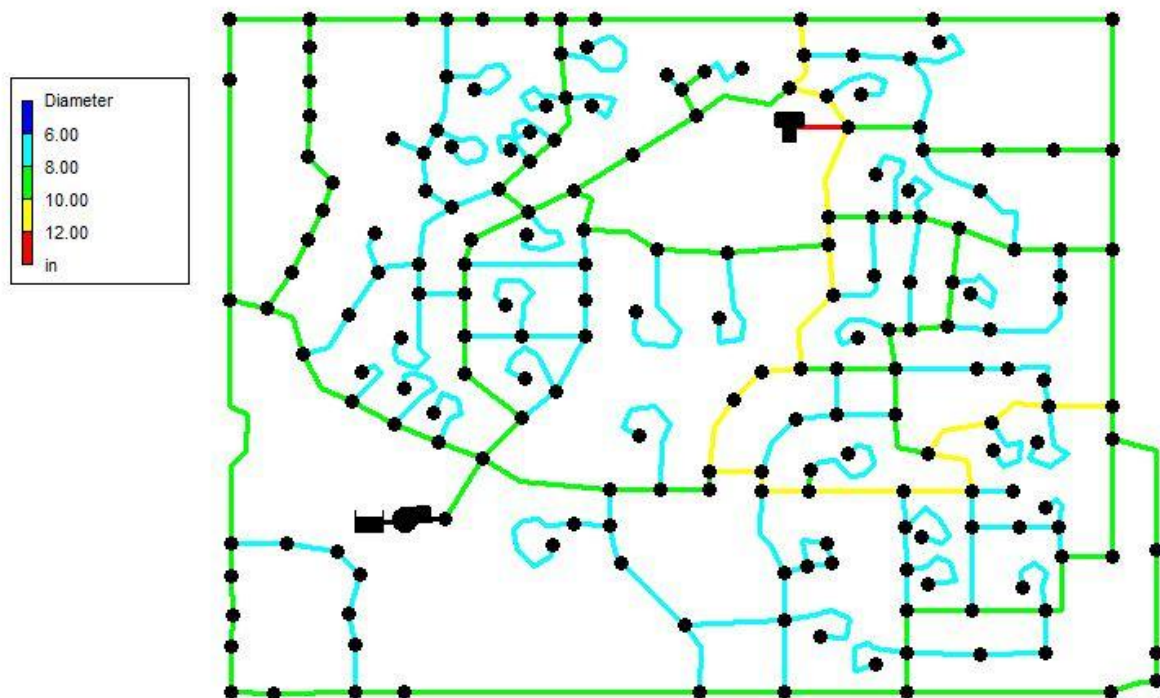

**Figure 3.23 Community Reclaimed Water Pipe Network and Pipe Diameters**

The location of the pump is different in the conventional and non-potable model because wastewater is treated within the community to supply the reclaimed water. The pump is located at the wastewater treatment plant, which produces the reclaimed water. In the conventional model the water was treated outside of the community.

The elevated storage tank provides storage of 922,000 gallons (3,490,000 l) to meet the peak day and fire flow requirements. Average day water use in the community is 369,000 gallons (1,396,800 l). The corresponding energy needed for pumping is 1100

Kw-hr/Mgal (0.000291 Kw-hr/ML). The pump used in the reclaimed water model is a Grundfos 800S750-3A.

As in the conventional model, the pump turns on when the system demand is greater than 1500 gpm (5678) or when the water level in storage is less than 20 ft (6.10 m). A water level of 20 ft (6.10 m) in the storage tank corresponds to the volume of water required to address a fire requiring a flow rate of 2400 gpm (9085 lpm) for 2 hours.

The water age in the elevated storage during peak flows in the non-potable model is 118 hours. During average day conditions, the water age in storage is 128 hours. The average water age for the reclaimed system is greater than the average water age for the conventional system (117 hours) because the potable demand has been reduced but the size of the pipes are the same to accommodate the fire flow requirements. Refer to Section 3.5.3 for a discussion on the importance of water age.

The file for the reclaimed community model is below. The directions for how to run the model are located in Appendix A.

### **3.5.5 Modified Potable Distribution System**

The potable distribution system delivers only the potable water supply. The end uses of potable water are sinks, dishwashers, and showers/baths. All of the water is treated to potable standards. Once again, the system is sized based on the potable peak flows listed previously in Section 3.5.2.

### ***EPANET 2***

The pipe network in the community potable model is the same as the conventional model. The only difference is the pipe diameters. Water is again treated to potable standards outside the community and then pumped into the community and stored in

elevated storage. Figure 3.24 shows the pipe network and the pipe diameters. Since the system is only distributing the potable demand, the pipes can be significantly smaller. Diameters less than two inches are adequate to handle flows in some areas in the community; however, diameters less than two inches are not used to reduce the chances of pipe clogging.

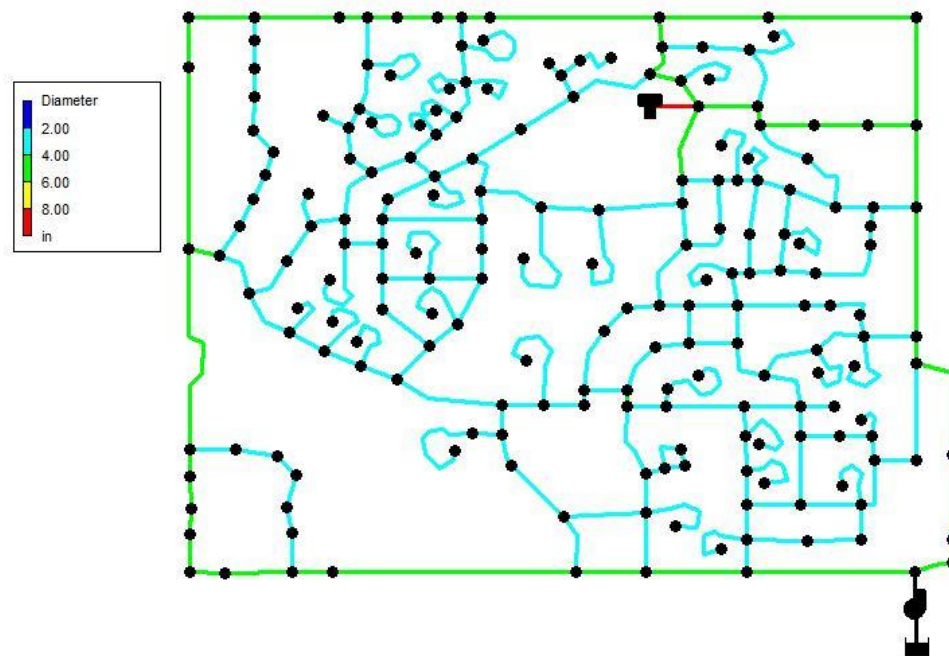

**Figure 3.24 Community Potable Pipe Network Showing Pipe Diameters**

The required pipe diameters were found by inputting only the potable demands into the conventional model. Then, the pipes were systematically reduced. The model was run multiple times during the pipe reduction process to ensure that the smaller pipes could deliver the peak flow. The criteria to determine pipe diameters are a velocity around 5 ft/s (1.52 m/s) and pressures between 40 and 110 psi (275.8-758.4 kpa) (Hammer and Hammer 2008; Viessman and Hammer 1998). In some areas, the pressure

exceeds the maximum pressure so pressure reducing valves will be required in the actual system. They were not considered in this model.

The elevated storage tank is sized to store the peak day demand of 367,000 gallons (1,389,000 l). The average day demand is 209,000 gallons (791,150 lpm), which corresponds to a pump energy requirement of 1545 Kw-hr/Mgal (0.00041 Kw-hr/ML). A Grundfos 625S600-3A is used for the potable system. The pump is programmed to turn on when the water level in the elevated storage falls below 3 ft (0.91 m). This is to ensure the tank never empties. Once the tank reaches this level, it takes approximately 17 hours for the tank to refill. During the peak day, the average water age in the elevated storage tank is 42 hours. Likewise, during an average day the water age increases to 52 hours. For a discussion on the importance of water age, refer to Section 3.5.3.

The file and directions for how to run the potable community model in EPANET are located in Appendix A..

### **3.5.6 Additional Infrastructure Requirements for Community**

The conventional water distribution system, which supplies potable water to meet all residential, commercial, and fire flow demands, is used as the baseline model for this analysis. The conventional system is compared to the dual distribution system, which has separate pipe networks for reclaimed water and potable water. Because of fire flow requirements, the pipe diameters and pumps for the two pipe networks are the same. The only difference is in storage capacity. The reclaimed system requires less elevated storage (922,000 gal, 3,490,000 l) than the conventional system (1,290,000 gal, 4,880,000 l). Other than storage, the two systems are identical; therefore, implementing the reclaimed water network does not require additional infrastructure.

The dual distribution system requires an additional pipe network for the potable portion. The additional materials required for the potable system are listed in Table 3.53.

**Table 3.53 Infrastructure Requirements for Community Potable Water Distribution System**

<b>Material</b>	<b>Amount</b>
2 in (50.8 mm) C900 PVC	69600 ft (21214 m)
4 in (101.6 mm) C900 PVC	25450 ft (7757 m)
8 in (203.2 mm) C900 PVC	129 ft (39.32 m)
2 in (50.8 mm) C900 PVC Long Radius Elbow	42
2 in (50.8 mm) C900 PVC 45 degree Bend	165
2 in (50.8 mm) C900 PVC Tee	1271
2 in (50.8 mm) C900 PVC Cross Connector	12
368,900 gallons (1,389,000 l) Elevated Storage	1
Grundfos 625S600-3A 60 HP Pump	1
2 in (50.8 mm) PVC Shutoff Valves	155
4 in (101.6 mm) PVC Shutoff Valves	32

Implementing a dual distribution system also requires an additional service line to each home and business, as well as additional plumbing in the buildings. The additional plumbing requirements for the service lines are determined by estimating the distance from the center of the street to the center of the house based on the AutoCAD files for the community. The service lines are for the reclaimed portion of the water system. It is likely that the service lines for the potable system could be reduced because of reduced demand, but that is not considered in this analysis. In addition, the residential indoor infrastructure requirements for dual distribution are calculated based off results from the residential house used in the first scenarios. The indoor infrastructure for the apartment building is determined by using a ratio of the building square footage to the apartment modeled in the apartment with rainwater use scenario. Indoor plumbing infrastructure for the other buildings is estimated by assuming that the service line connects to the center of the building where the restrooms (the main use of reclaimed water in the building) are

located. The numbers used for the service line connections and additional indoor plumbing requirements are given in Table 3.54 through Table 3.56.

**Table 3.54 Service Line and Indoor Plumbing Requirements for Single-Family Residence.**

<b>Material</b>	<b>Per House</b>	<b>Community Total</b>
1/2" (12.7 mm) PEX	127 ft (39 m)	152,273 (46,413 m)
Manifold 3, 1/2" (12.7 mm) outflow connections	1	1199
1" (25.4 mm) Service Line	80 ft (24 m)	95920 (29,234 m)

**Table 3.55 Service Line and Indoor Plumbing Requirements for Community Apartment Buildings.**

	<b>Apartment 1 (7 buildings)</b>	<b>Apartment 2 (6 buildings)</b>	<b>Apartment 3 (1 building)</b>	<b>Apartment 4 (8 buildings)</b>	<b>Totals</b>
Percent of Model Apartment per building	36%	54%	306%	38%	
2 outflow line manifold (2" (50.8 mm) to 2, 1/2" (12.7 mm) outputs)	182	232	220	221	855
3 outflow line manifold (2" (50.8 mm) to 3, 1/2" (12.7 mm) outputs)	273	348	331	331	1283
2 in (50.8 mm) PVC	13046 ft (3976 m)	16660 ft (5078 m)	15804 ft (4817 m)	15816 ft (4821 m)	61326 ft (18692 m)
2 in (50.8 mm) PVC tee connections	440	561	533	533	2067
3 in (76.2 mm) to 2 in (50.8 mm) PVC Reducers	42	36	6	48	132
3 in (76.2 mm) PVC tees	21	18	3	24	66
3 in (76.2 mm) 90 degree PVC elbows	56	48	8	64	176
3 in (7.2 mm) PVC tees	14	12	2	16	44
3 in (76.2 mm) PVC (ft)	315	270	45	360	990
Service Line Length (1.5 in (38.1 mm) diameter)	2280 ft (695 m)	1890 ft (576 m)	175 ft (53 m)	2400 ft (732 m)	6745 ft (2056 m)

**Table 3.56 Service Line and Indoor Plumbing Requirements for Community Non-Residential Buildings.**

Building	Service Line Diameter		Service Line Length		Inside pipe (PVC) 1 in (25.4 mm) diameter	
	in	mm	ft	m	ft	m
School	2	50.8	360	110	150	46
Fast Food Restaurant 1	1	25.4	460	140	15	5
Fast Food Restaurant 2	1	25.4	135	41	15	5
Fast Food Restaurant 3	1	25.4	290	88	15	5
Service Station	1	25.4	200	61	20	6
Large Office Building	1	25.4	285	87	40	12
Pharmacy	1	25.4	235	72	30	9
Doctor's Office	1	25.4	85	26	40	12
Urgent Care Office	1	25.4	200	61	20	6
Dentist Office	1	25.4	185	56	20	6
Bank	1	25.4	190	58	40	12
Church	1	25.4	80	24	20	6
Outlet Stores	1	25.4	315	96	100	30
Restaurant 1	1	25.4	195	59	15	5
Restaurant 2	1	25.4	125	38	15	5
Restaurant 3	1	25.4	390	119	15	5
Restaurant 4	1	25.4	255	78	15	5
Supermarket	1	25.4	205	62	50	15
Spa	1	25.4	105	32	20	6
Hotel	1.5	38.1	190	58	100	30
<b>Totals</b>						
1 in (25.4 mm) PVC		4690 ft	1430 m			
1.5 in (38.1 mm) PVC		190 ft	58 m			
2 in (50.8 mm) PVC		360 ft	110 m			

### 3.5.7 Benefits of Large Scale Reclaimed Water Use

Benefits associated with large-scale reclaimed water use include reduced treatment costs, improved potable water quality, and decreased freshwater withdrawals. Drinking water treatment costs are reduced because the quantity of water treated to drinking water

standards is reduced. The cost of wastewater treatment may increase some because of the higher treatment required for reclaimed water, but this can be offset by charging for reclaimed water use. Removing the non-potable demands from the potable system allows the pipe sizes of the potable system to be reduced resulting in decreased water age. Smaller water ages decrease the formation of disinfection by-products and microbial regrowth, leading to higher water quality at the tap. Using reclaimed water to meet the non-potable demand reduces the amount the freshwater withdrawals. The reclaimed water is now another water source for the community.

### **3.6 Implementation in Different Regions**

The infrastructure requirements are very similar for the different regions studied in the United States (Pacific Northwest, Desert Southwest, Midwest, and Southeast). Most of the infrastructure such as pipes and pumps are designed based on flow rates, which are similar across the country. Differences in infrastructure requirements for the residential and apartment building models occur when the design is dependent on the climate, such as rainwater harvesting. The amount and frequency of rainfall affected the size of the drainage and water storage in the residential and apartment rainwater harvesting models. Therefore, each region requires slightly different infrastructure.

For example, in the apartment model, Seattle requires a 30,000 gallon (113,562 l) cistern to store water because it experiences more constant rainfall. The other regions, have more seasonal rainfall variation so more storage is required to capture water during the rainy season so it can be used during the dry season.



## **4 Results and Discussion**

### **4.1 Results**

In each of the scenarios studied, additional infrastructure is needed to implement a dual distribution system. The least complex systems are simple greywater reuse for subsurface irrigation and rainwater harvesting. If treatment is used, the system becomes more complex and infrastructure intensive. In some cases, it is beneficial to pair two reuse systems together such as outdoor subsurface irrigation with untreated greywater and rainwater harvesting for indoor non-potable uses. This can eliminate treatment because rainwater is higher quality than greywater and usually does not require treatment. A design guide giving instructions on how to implement greywater reuse and rainwater harvesting is located in Appendix G.

#### **4.1.1 Greywater Reuse**

In the typical home, approximately 130 feet (39.6 m) of additional 2-inch PVC pipe is needed to collect untreated greywater for outdoor subsurface irrigation. The amount of outdoor infrastructure is dependent on the regional climate and the vegetation. Using untreated greywater for subsurface irrigation requires a rather simple system on the household scale. Greywater is collected from bathroom sinks, clothes washing, and showers and delivered to the yard for subsurface irrigation.

In a single-family home using a typical greywater treatment and indoor reuse scenario, an extra 102 feet (31 m) of 2-inch (50.8 mm) PVC pipe and 127 feet (38.7 m) of ½ inch (12.7 mm) cross-linked polyethylene (PEX) pipe is needed for collection and redistribution, respectively. Before water collected from bathroom sinks and showers can be used for toilet flushing and clothes washing, it must first be treated. The treatment

used in this study is a membrane bioreactor. Other significant infrastructure requirements include two storage tanks, a pump and the membrane bioreactor unit.

#### 4.1.2 Rainwater Harvesting

In a typical single-family home using rainwater harvesting, 164 feet (50 m) of ½ inch (12.7 mm) PEX pipe is required to distribute rainwater in the house for toilet flushing and clothes washing. The outdoor rainwater harvesting infrastructure requirements vary by climate and depth of the cistern. Table 4.1 summarizes the material requirements by city. In addition to the material requirements listed below, four first-flush diverters and four downspout filters are also required.

**Table 4.1 Summary of Rainwater Harvesting Materials for a Single-Family Home**

City	60 minute 100 year rainfall		Cistern Size		Underground PVC Pipe	
	in/hr	mm/hr	gal	l	English	Metric
Seattle	1.0	25.4	2500	9464	147 ft, 3 in PVC	44.8 m, 76.2 mm PVC
Scottsdale	2.2	55.88	2500	9464	147 ft, 3 in PVC	44.8 m, 76.2 mm PVC
Omaha	3.6	91.44	2500	9464	152 ft, 4 in PVC	46.3 m, 101.6 mm PVC
Tampa	4.2	106.68	2500	9464	147 ft, 5 in PVC	44.8 m, 76.2 mm PVC

In the apartment building model, more than 5,000 feet (1524 m) of 2 inch (50.8 mm) PVC is required to distribute the harvested rainwater. The rainwater is used for toilet flushing and clothes washing. Seattle requires a 30,000 gallon (113,562 l) cistern while Scottsdale, Omaha, and Tampa all need a 50,000 gallon (189,270 l) cistern. Seattle can use a smaller cistern because it has a uniform rainfall pattern throughout the year. The underground piping system is the same for all of the communities.

### **4.1.3 Reclaimed Water Reuse**

During an average day, a dual distribution system in a typical community will save 370,000 gallons (1,400,000 l) of water not used for human consumption from being treated to drinking water quality. A complete second pipe network is required for the reclaimed water use in the community. The conventional system and reclaimed water system are identical. The two systems are identical because they both supply fire flow and in this situation, the fire flow determines the required pipe diameters in the community. In addition, to the reclaimed system, a second system with smaller pipe diameter is required for the potable system. The potable system is made up of 2-inch (50.8 mm) and 4-inch (101.6 mm) diameter pipes. Separating the potable and non-potable uses reduces the residence time of water in the potable system leading to improved water quality.

## **4.2 Discussion**

The use of dual distribution shows promise to combat the issues of water scarcity. Using greywater or reclaimed water within the community reduces the amount of raw water that must be withdrawn from the environment. Likewise, rainwater is a free water source, and its utilization can help reduce the amount of water withdrawn, treated, and delivered.

One drawback with all reuse systems is the requirement to have separate piping systems for each different water quality. The redundancy leads to additional infrastructure costs, which can hinder the implementation of dual systems. One way of making the added expense more viable is to increase water prices. Higher prices for potable water will lead consumers to utilize potable water more efficiently, and the increased infrastructure costs will be compensated for by reduced water costs.

## **5 Conclusions and Recommendations**

### **5.1 Conclusions**

Implementing dual distribution systems is a way to reduce the potable water demand. A dual distribution system shifts some of the water demand from the potable system to a combination of potable and non-potable water depending on the end use. Advantages of a dual distribution system include avoiding large costs to treat water not used for human consumption to drinking water standards and improving the quality of water that is used for human consumption. A drawback associated with a dual distribution system is the needed increase in infrastructure.

### **5.2 Recommendations for Future Study and Analysis**

The focus of this study is determining the infrastructure to meet the current water demands. Low flow rate fixtures are considered in the analysis but additional water conservation measures such as xeroscaping were not considered. Therefore, in future studies it may be valuable to determine what the infrastructure needs are based on the implementation of additional water conservation measures.

## 6 References

- Aladenola, O. O., and Adeboye, O. B. (2010). "Assessing the Potential for Rainwater Harvesting." *Water Resources Management*, 24 2129-2137.
- Al-Jayyousi, O. R. (2003). "Greywater reuse: towards sustainable water management." *Desalination*, 156 181-192.
- Alkhatib, R. Y., Roesner, L. A. and Marjoram, C. (2006). "An Overview of Graywater Collection and Treatment Systems." [http://www.engr.colostate.edu/HHSLab/papers/EWRI%202006%20Alkhatib\\_Roesner&Marjoram.pdf](http://www.engr.colostate.edu/HHSLab/papers/EWRI%202006%20Alkhatib_Roesner&Marjoram.pdf) (4/20, 2010).
- Ameen, J. S. (1971). *Community water systems source book: commercial, institutional, residential, industrial applications*. Technical Proceedings, High Point, N.C.
- Appan, A. (1999). "A dual-mode system for harnessing roofwater for non-potable uses." *Urban Water*, 1 317-321.
- Asano, T. (2007). *Water reuse: Issues, Technology, and Applications*. McGraw-Hill, New York.
- AWWA. (2009). *Planning for the Distribution of Reclaimed Water*. American Water Works Association, Denver, CO.
- AWWA. (2008). *Distribution System Requirements for Fire Protection*. American Water Works Association, Denver, CO.
- AWWA. (2004). *Sizing Water Service Lines and Meters*. American Water Works Association, Denver, CO.
- AWWA. (2001). "Dawn of the Replacement Era: Reinvesting in Drinking Water Infrastructure." American Water Works Association, Denver, CO.
- AWWARF. (1993). *Residential Water Use Patterns*. AWWA Research Foundation, Denver, CO.
- California Energy Commission. (2010). "Clothes Washers-Energy Choices at the Home." <http://www.consumerenergycenter.org/home/appliances/washers>. (4/12, 2010).
- Christova-Boal, D., Eden, R. E., and McFarlane, S. (1996). "An investigation into greywater reuse for urban residential properties." *Desalination*, 106 391-397.
- Congressional Budget Office. (2002). "Future Investment in Drinking Water and Wastewater Infrastructure." Congressional Budget Office.

Coombes, P. J., and Barry, M. E. (2007). "The effect of selection of time steps and average assumptions on the continuous simulation of rainwater harvesting strategies." *Water Science and Technology*, 55(4), 125-133.

Daigger, G. T. (2009). "Evolving Urban Water and Residuals Management Paradigms: Water Reclamation and Reuse, Decentralization, and Resource Recovery." *Water Environment Research*, 81(8), 809-823.

DiGiano, F. A., Weaver, C. C., and Okun, D. A. (2009). "Benefits of shifting fire protection to reclaimed water." *Journal AWWA*, 101(2), 65-73.

Dixon, A., Bulter, D., Fewkes, A., and Robinson, M. (1999). "Measurement and modelling of quality changes in stored untreated grey water." *Urban Water*, 1 293-306.

Eriksson, E., Auffarth, K., Eilersen, A., Henze, M., and Ledin, A. (2003). "Household chemicals and personal care products as sources for xenobiotic organic compounds in grey wastewater." *Water SA*, 29(2), 135-146.

Eriksson, E., Auffarth, K., Henze, M., and Ledin, A. (2002). "Characteristics of grey wastewater." *Urban Water*, 4 85-104.

Fane, S. A., Ashbolt, N. J., and White, S. B. (2002). "Decentralised urban water reuse: The implications of system scale for cost and pathogen risk." *Water Science and Technology*, 46(6-7), 281-288.

Floyd, R. P. (1978). "Geodetic Bench Marks." *Rep. No. NOAA Manual NOS NGS 1*, National Oceanic and Atmospheric Administration, Rockville, MD.

Gardels, D. (2011). "Economic Input-Output Life Cycle Assessment of Water Reuse Strategies in Residential Buildings and Communities." .

Google. (2010). "Google Earth."

Gupta, R. S. (2008). *Hydrology and Hydraulic Systems*. Waveland Press, Long Grove, IL.

Hammer, M. J., and Hammer, M. J., Jr. (2008). *Water and Wastewater Technology*. Prentice Hall, Boston.

Harremoes, P. (2000). "Advanced water treatment as a tool in water scarcity management." *Water Science and Technology*, 42(12), 73-92.

Huston, R., Chan, Y. C., Gardner, T., Shaw, G., and Chapman, H. (2009). "Characterisation of atmospheric deposition as a source of contaminants in urban rainwater tanks." *Water Research*, 43 1630-1640.

Ishida, C. K., Petropoulou, C., Stober, T., Steets, B., Strecker, E., Chatti, D., and Salveson, A. (2009). "Evaluating Greywater for Unrestricted Use." *Water Environment Federation Technical Exhibition and Conference*, 1863-1869.

Jefferson, B., Palmer, A., Jeffrey, P., Stuetz, R., and Judd, S. (2004). "Grey water characterisation and its impact on the selection and operation of technologies for urban reuse." *Water Science & Technology*, 50(2), 157-164.

Jones, M. (2010). "Rainwater Harvester." 2.0.

Kloss, C. (2008). "Managing Wet Weather with Green Infrastructure." *Rep. No. EPA-833-F-08-010*, Environmental Protection Agency, .

Lamont, P. A. (1981). "Common pipe flow formulas compared with the theory or roughness." *Journal AWWA*, 73(5), 274-280.

Lancaster, B. (2011). "Rainwater Harvesting for Drylands and Beyond." [www.harvestingrainwater.com](http://www.harvestingrainwater.com) (02/22, 2011).

Lee, J. Y., Yang, J., Han, M., and Choi, J. (2010). "Comparison of the microbiological and chemical characterization of harvested rainwater and reservoir water as alternative water resources." *Sci.Total Environ.*, 408(4), 896-905.

Li, F., Wichmann, K., and Otterpohl, R. (2009). "Evaluation of appropriate technologies for grey water treatments and reuses." *Water Science & Technology, WST*, 59(2), 249-260.

Lu, W., and Leung, A. Y. T. (2003). "A preliminary study on potential of developing shower/laundry wastewater reclamation and reuse system." *Chemosphere*, 52 1451-1459.

Ludwig, A. (2009). *The New Create and Oasis with Greywater: Choosing, Building, and Using Greywater Systems-Includes Branched Drains*. Oasis Designs, .

Mayer, P. W., DeOreo, W. B., Opitz, E. M., Kiefer, J. C., Davis, W. Y., Dzlegiefewski, B., and Nelson, J. O. (1999). *Residential End Uses of Water*. AWWA Research Foundation, .

Moen. (2010). "Moen 6" Outdoor Faucet." (9/16, 2010).

Moglia, M., Cook, S., Sharma, A. K., and Burn, S. (2010). "Assessing Decentralised Water Solutions: Towards a Framework for Adaptive Learning." *Water Resources Management*, (Online),.

National Fire Protection Association. (2006). *Uniform Fire Code Handbook*.

North Carolina Department of Environment and Natural Resources. (2009). "Water Efficiency Manual for Commercial, Industrial, and Institutional Facilities." <http://www.p2pays.org/ref/01/00692.pdf> (10/1, 2010).

North Carolina Environmental Management Commission. (2001). "Waste Not Discharged to Surface Waters." <http://h2o.enr.state.nc.us/admin/rules/2H.0200.pdf> (9/14, 2010).

Novotny, V., Ahern, J., and Brown, P. (2010). *Water Centric Sustainable Communities: Planning, Retrofitting, and Building the Next Urban Environment*. John Wiley & Sons, Inc., Hoboken, New Jersey.

Okun, D. A. (1997). "Distributing reclaimed water through dual systems." *American Water Works Association*, 89(11), 52-64.

Ottoson, J., and Stenstrom, T. A. (2003). "Faecal contamination of greywater and associated microbial risks." *Water Research*, 37 645-655.

Plastics Pipe Institute. (2010). "Differences between PEX and PB Systems for Potable Water Applications." *Rep. No. TN-31*, Plastics Pipe Institute.

Plastics Pipe Institute. (2000). "Water Flow Characteristics of Thermoplastic Pipe." Plastics Pipe Institute, Washington, D.C.

Plumbing-Heating-Cooling Contractors Association. (2006). *National Standard Plumbing Code*. Plumbing-Heating-Cooling Contractors National Association, Falls Church, VA.

RainHarvest Systems. (2011). "Tanks." <http://www.rainharvest.com/shop/shopdisplaycategories.asp?id=19&cat=Tanks> (02/22, 2011).

RainHarvest Systems. (2010a). "Downspout First Flush Diverters." <http://www.rainharvest.com/shop/shopexd.asp?id=269> (5/14, 2010).

RainHarvest Systems. (2010b). "First Flush Diverter for In Ground Systems." <http://www.rainharvest.com/shop/shopexd.asp?id=81> (7/7, 2010).

RainHarvest Systems. (2010c). "First Flush Diverters." Personal Communication.

Sheikh, B. (2010). "White Paper on Graywater." *Water Reuse Association*, .

Surendran, S., and Wheatley, A. D. (1998). "Grey-Water Reclamation for Non-Potable Re-Use." *Journal of Chartered Institution of Water and Environmental Management*, 12(December), 406-413.



Sweet, J. (2010). "Cross-Linked Polyethylene Tubing." *Reeves Journal*, 90(3), 28-29.

Texas Water Development Board. (2005). "The Texas Manual on Rainwater Harvesting." *Rep. No. Third Edition*, Texas Water Development Board, Austin, Texas.

Toto. (2009). "Eco Promenade Close Coupled Toilet, 1.28 GPF." <http://admin.totousa.com/Product%20Downloads/SS-00237,%20CST424EF,%20CST424EFG,%20V.07.pdf> (4/17, 2010).

United States Environmental Protection Agency. (2011). "Drinking Water Contaminants." <http://water.epa.gov/drink/contaminants/index.cfm#Primary> (2/9, 2011).

USEPA. (2010a). "EPANET." <http://www.epa.gov/nrmrl/wswrd/dw/epanet.html> (9/28, 2010).

USEPA. (2010b). "Sustainable Infrastructure: Basic Information." <http://water.epa.gov/infrastructure/sustain/basicinformation.cfm> (2/7, 2011).

USEPA. (2010c). "Sustainable Infrastructure: Infrastructure Gap." <http://water.epa.gov/infrastructure/sustain/infrastructuregap.cfm> (2/7, 2011).

USEPA. (2004). "Guidelines for Water Reuse." *Rep. No. EPA/625/R-04/108*, U. S. Environmental Protection Agency, Washington, DC.

USEPA. (2002). "Effects of Water Age on Distribution System Water Quality." United States Environmental Protection Agency, Washington, DC.

USEPA, and U.S. Department of Energy. "Dishwashers Key Product Criteria." [http://www.energystar.gov/index.cfm?c=dishwash.pr\\_crit\\_dishwashers](http://www.energystar.gov/index.cfm?c=dishwash.pr_crit_dishwashers) (9/9, 2010).

USGBC. (2008). *LEED for Homes Reference Guide*. United States Green Building Council, Washington, DC.

Venhuizen, D. (2008). "Distributed Wastewater Management: The More Sustainable Strategy." *Water Environ.Technol.*, 20(4), 10, 12, 14.

Viessman, W., and Hammer, M. J. (1998). *Water Supply and Pollution Control*. Addison Wesley, Menlo Park, CA.

Walker, J. (2010). "Engineered Rainwater Collection and Case Studies for Sustainable Water Management." Webinar.

Whirlpool. (2009). "Front-Loading Automatic Washer Use and Care Guide." [http://www.whirlpool.com/assets/pdfs/product/ZUSECARE/WFW9750WW\\_Use%20and%20Care\\_EN.pdf](http://www.whirlpool.com/assets/pdfs/product/ZUSECARE/WFW9750WW_Use%20and%20Care_EN.pdf) (4/17, 2010).

Zhang, Y., Grant, A., Sharma, A., Chen, D., and Chen, L. (2010). "Alternative Water Resources for Rural Residential Development in Western Australia." *Water Resource Management*, 24 25-36.

## 7 Appendices

## **Appendix A Directions for EPANET 2 Models**

EPANET 2.0 is a free hydraulic modeling software program that can be downloaded from <http://www.epa.gov/nrmrl/wswrd/dw/epanet.html>.

### Simple Greywater Reuse System

1. Open the EPANET software. Download and then open the [Simple Greywater Reuse System](#) model.
2. To run the model click on the lightning bolt icon along the toolbar or click “Run Analysis” under “Project” above the toolbar. See arrow below in Figure 1.

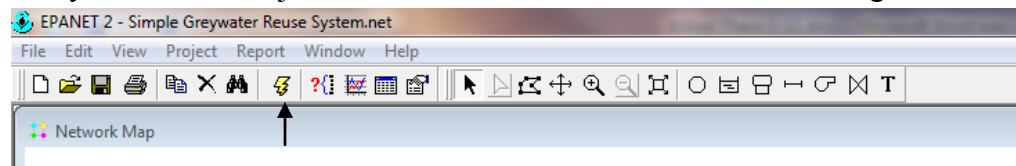

**Figure 1. Location of icon to run EPANET.**

3. The simulation runtime can be changed in the “Browser” window, under the “Data” tab by selecting “Options” as shown in Figure 2 below.

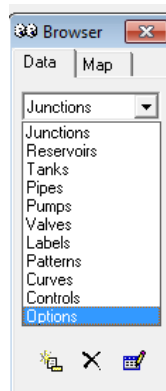

**Figure 2. Selecting “Options” in the “Browser” window to change the time of simulation.**

4. Under the options menu select “Times.” The window shown in Figure 3 will appear. From this window, the duration of the simulation can be changed as well as the hydraulic and reporting time steps. The pattern time step should not be changed.

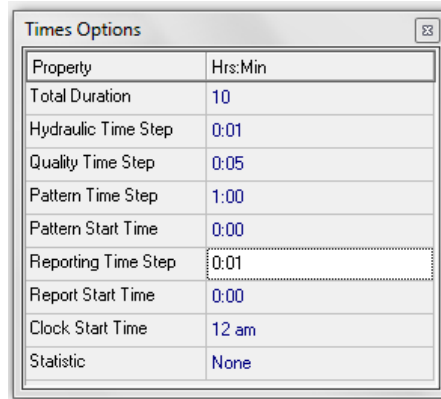

**Figure 3. “Time Options” menu in EPANET.**

5. Node and pipe properties are displayed by double clicking on the node or pipe of interest.
6. To view the various properties of the pipe throughout the simulation, click on the “Map” tab in the “Browser” window as shown below in Figure 4. The browser window opens with the program. It can also be launched by clicking “Window” above the toolbar and selecting “Browser.” One parameter can be selected for nodes and links in the system. A specific time can also be investigated. To start the real-time viewing of the simulation, click the forward arrow. The speed of the duration can be controlled using the slider at the bottom of the window.

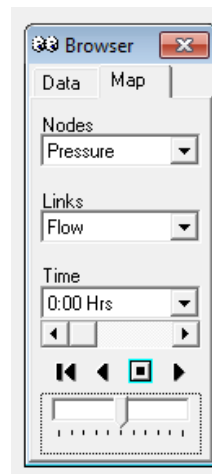

**Figure 4. Map tab in EPANET Browser window.**

7. To graph the parameter of interest for a node, pipe, or group of similar objects. Click the graph button shown in Figure 5. Once the new window opens select the node(s) or pipe(s) of interest and click add. The graph type and parameter of interest are also selected in this window. Click “OK” to create the graph.

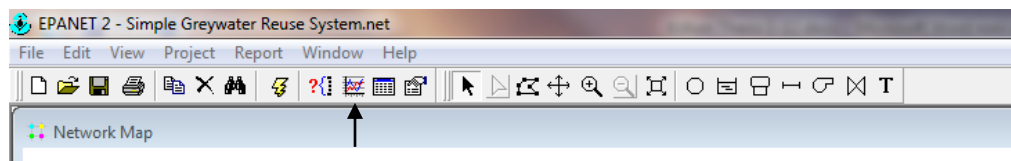

**Figure 5. Location of icon to graph node or pipe parameters in EPANET.**

8. A flow control valve (FCV) represents each fixture in the model. The frequency and duration of use can be adjusted using the “Simple Controls” editor. The editor is launched from the browser window. In the “Browser” window, click the down arrow so the entire options menu is available and then select controls as shown below in Figure 6. Under the controls menu select “Simple Controls.” This will bring up a window filled with the code that controls the operation of the FCV.

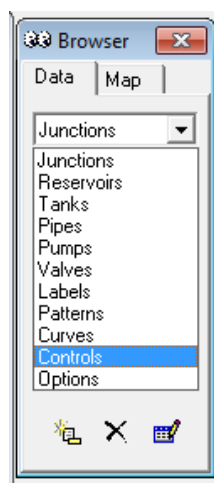

**Figure 6. EPANET Browser window to launch simple controls editor.**

This will bring up a window filled with the code that controls the operation of the FCV. See Figure 7 below.

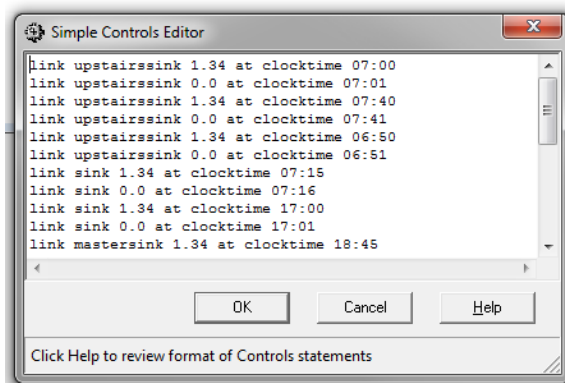
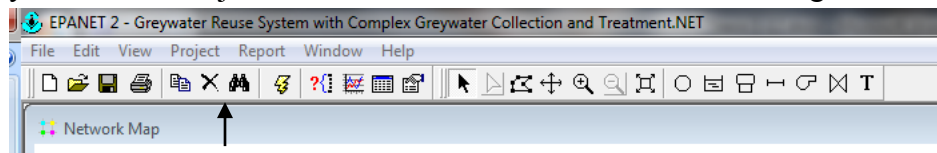

**Figure 7. Simple Controls Editor in EPANET**

- To increase the frequency of use, copy and paste a command line from the fixture of interest and change the associated time. Similarly, the duration can be increased or decreased by changing the time the FCV is open.

### **Greywater Reuse System with Complex Greywater Collection and Treatment and Greywater Reuse System with Rainwater Harvesting**

- Open the EPANET software. Download and then open the either [Greywater Reuse System with Complex Greywater Collection and Treatment](#) model or the [Greywater Reuse System with Rainwater Harvesting](#) model.
- To run the model click on the lightning bolt icon along the toolbar or click “Run Analysis” under “Project” above the toolbar. See arrow below in Figure 1.



**Figure 1. Location of icon to run EPANET.**

- The simulation runtime can be changed in the “Browser” window, under the “Data” tab by selecting “Options” as shown in Figure 2 below.

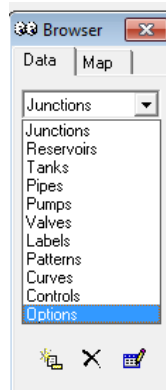

**Figure 2. Selecting “Options” in the “Browser” window to change the time of simulation.**

- Under the options menu select “Times.” The window shown in Figure 3 will appear. From this window, the duration of the simulation can be changed as well as the hydraulic and reporting time steps. The pattern time step should not be changed.



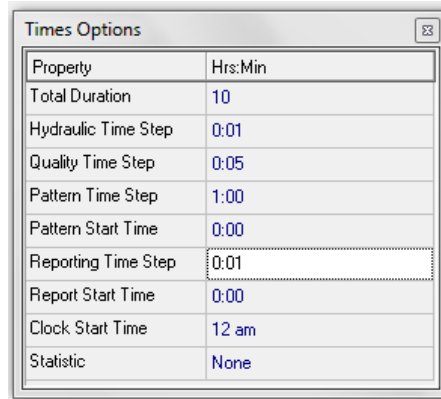

**Figure 3. “Time Options” menu in EPANET.**

5. Node and pipe properties are displayed by double clicking on the node or pipe of interest.
6. To view the various properties of the pipe throughout the simulation, click on the “Map” tab in the “Browser” window as shown below in Figure 4. The browser window opens with the program. It can also be launched by clicking “Window” above the toolbar and selecting “Browser.” One parameter can be selected for nodes and links in the system. A specific time can also be investigated. To start the real-time viewing of the simulation, click the forward arrow. The speed of the duration can be controlled using the slider at the bottom of the window.

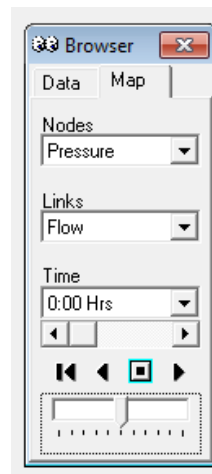

**Figure 4. Map tab in EPANET Browser window.**

7. To graph the parameter of interest for a node, pipe, or group of similar objects. Click the graph button shown in Figure 5. Once the new window opens select the node(s) or pipe(s) of interest and click add. The graph type and parameter of interest are also selected in this window. Click “OK” to create the graph.

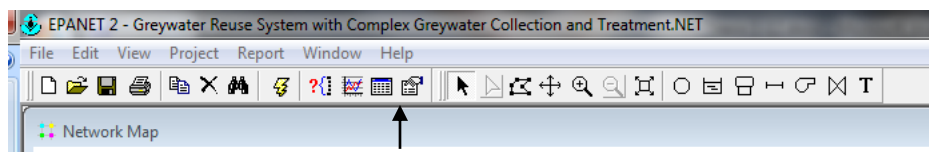

**Figure 5. Location of icon to graph node or pipe parameters in EPANET.**

8. A flow control valve (FCV) represents each fixture in the model. The frequency and duration of use can be adjusted using the “Simple Controls” editor. The editor is launched from the browser window. In the “Browser” window, click the down arrow so the entire options menu is available and then select controls as shown below in Figure 6. Under the controls menu select “Simple Controls.” This will bring up a window filled with the code that controls the operation of the FCV.

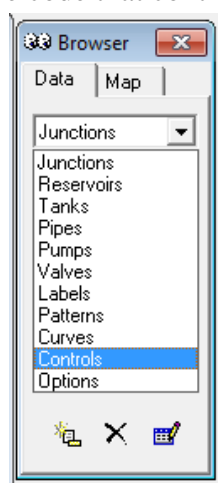

**Figure 6. EPANET Browser window to launch simple controls editor.**

This will bring up a window filled with the code that controls the operation of the FCV. See Figure 7 below.

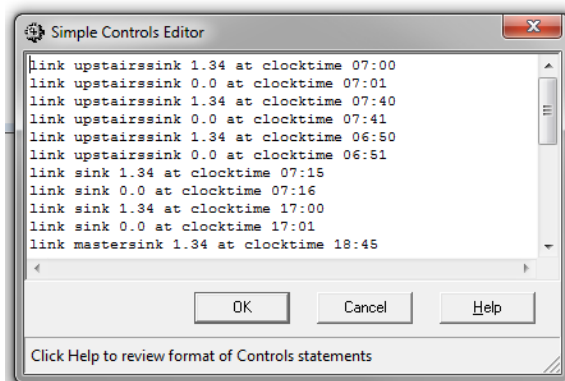
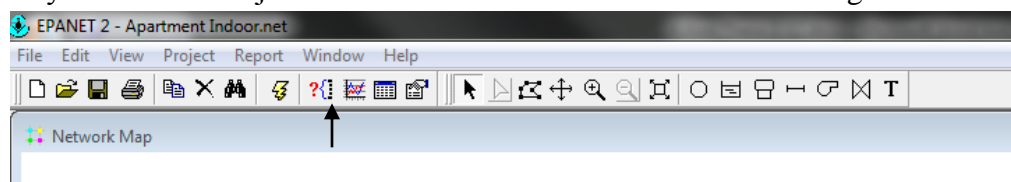

**Figure 7. Simple Controls Editor in EPANET**

9. To increase the frequency of use, copy and paste a command line from the fixture of interest and change the associated time. Similarly, the duration can be increased or decreased by changing the time the FCV is open.
10. The treatment (only for Greywater Reuse System with Complex Collection and Treatment) and redistribution system is modeled using rule-based controls. The rule-based controls are also accessed under the controls menu as described above. The controls in the rule-based editor are mostly dependent on water levels in tanks. Once again these parameters can be changed by changing the levels in the tanks. When changing the levels associated with the tanks it is important to make sure the parameters in the editor do not conflict with the parameters of the tank. This can be checked by double-clicking on the tank of interest and inspecting the listed properties.

### Apartment

1. Open the EPANET software. Download and then open the [Apartment Indoor](#) model.
2. To run the model click on the lightning bolt icon along the toolbar or click “Run Analysis” under “Project” above the toolbar. See arrow below in Figure 1.



**Figure 1. Location of icon to run EPANET.**

3. The simulation runtime can be changed in the “Browser” window, under the “Data” tab by selecting “Options” as shown in Figure 2 below.

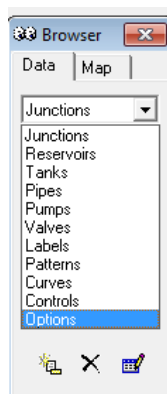

**Figure 2. Selecting “Options” in the “Browser” window to change the time of simulation.**

- Under the options menu select “Times.” The window shown in Figure 3 will appear. From this window, the duration of the simulation can be changed as well as the hydraulic and reporting time steps. The pattern time step should not be changed.

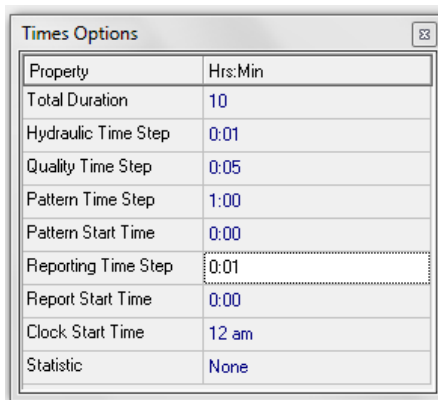

**Figure 3. “Time Options” menu in EPANET.**

- Node and pipe properties are displayed by double clicking on the node or pipe of interest.
- To view the various properties of the pipe throughout the simulation, click on the “Map” tab in the “Browser” window as shown below in Figure 4. The browser window opens with the program. It can also be launched by clicking “Window” above the toolbar and selecting “Browser.” One parameter can be selected for nodes and links in the system. A specific time can also be investigated. To start the real-time viewing of the simulation, click the forward arrow. The speed of the duration can be controlled using the slider at the bottom of the window.

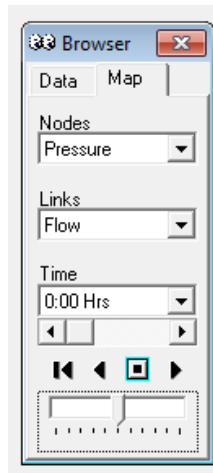

**Figure 4. Map tab in EPANET Browser window.**

7. To graph the parameter of interest for a node, pipe, or group of similar objects. Click the graph button shown in Figure 5. Once the new window opens select the node(s) or pipe(s) of interest and click add. The graph type and parameter of interest are also selected in this window. Click “OK” to create the graph.

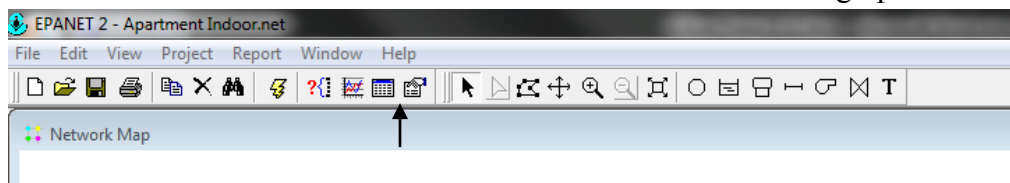

**Figure 5. Location of icon to graph node or pipe parameters in EPANET.**

8. A flow control valve (FCV) represents each apartment in the model. The frequency and duration of use can be adjusted using the “Simple Controls” editor. The editor is launched from the browser window. In the “Browser” window, click the down arrow so the entire options menu is available and then select controls as shown below in Figure 6. Under the controls menu select “Simple Controls.” This will bring up a window filled with the code that controls the operation of the FCV.

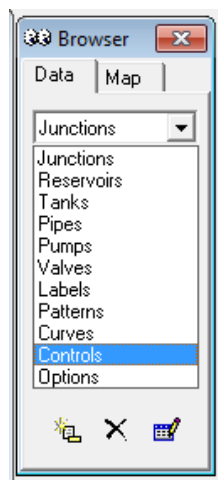

**Figure 6. EPANET Browser window to launch simple controls editor.**

This will bring up a window filled with the code that controls the operation of the FCV. See Figure 7 below.

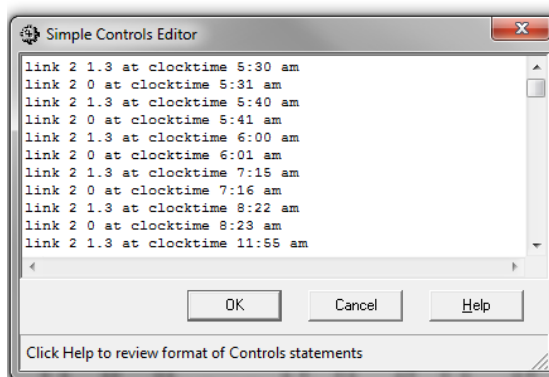
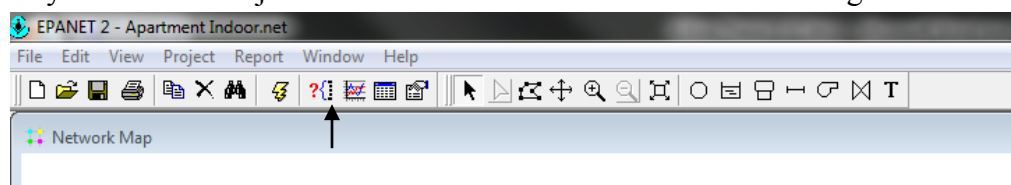

**Figure 7. Simple Controls Editor in EPANET**

9. To increase the frequency of use, copy and paste a command line from the fixture of interest and change the associated time. Since each apartment is represented by only one FCV, the type of fixture used is only denoted by the flow rate. A flow rate of 1.3 corresponds to a toilet flush, while a flow rate of 5 corresponds to clothes washing. Similarly, the duration can be increased or decreased by changing the time the FCV is open.
10. The rainwater distribution system is modeled using rule-based controls. The rule-based controls are also accessed under the controls menu as described above. The controls in the rule-based editor are dependent on the pressures in the pressure tank. Once again, these parameters can be changed by changing the assigned pressure in the tank.

### Apartment Rain Harvest

1. Open the EPANET software. Download and then open the [Apartment Rain Harvest](#) model.
2. To run the model click on the lightning bolt icon along the toolbar or click “Run Analysis” under “Project” above the toolbar. See arrow below in Figure 1.



**Figure 1. Location of icon to run EPANET.**

3. The model is designed to handle the flow from a 100 year return period, 60 minute duration storm intensity in the four study cities. Table 1 lists the cities, the corresponding intensity, and the pattern multiplier number in EPANET. The pattern for each city simulates a 1 hour storm at the intensity given in Table 1.

**Table 1. Storm intensity and Pattern Multiplier in EPANET 2 for study cities.**

City	100 Year Return Period, 60 Minute Duration Intensity		Pattern Multiplier
	in/hr	mm/hr	
Seattle	1.0	25.40	0.0104
Scottsdale	2.2	55.88	0.0229
Omaha	3.6	91.44	0.0374
Tampa	4.2	106.68	0.0436

4. To change the intensity of the rainfall, the following conversion must be done. First, select the desired intensity. The example below will use 2 in/hr.

$$\frac{2 \text{ in}}{\text{hr}} \times \frac{1 \text{ hr}}{60 \text{ min}} \times \frac{1 \text{ ft}}{12 \text{ in}} \times \frac{7.48 \text{ gal}}{\text{ft}^3} = \frac{0.0208 \text{ gal}}{\text{min} \times \text{ft}^2}$$

The base demand for each node corresponds to the subcatchment area in square feet. Therefore, when the value in the pattern is multiplied by the base demand the result is a flow rate in gallons per minute.

5. Once the new input for the pattern is determined, the pattern can be changed by clicking on “Patterns” in the “Browser” window as in Figure 2. The multiplier in the patterns editor is multiplied by the base demand to give the actual demand.

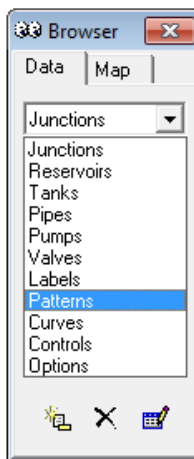
**Figure 2. Accessing Patterns editor in EPANET 2.**

6. After double clicking “Patterns”, the window in Figure 3 will appear. The default value for the pattern is the value for Seattle. If another intensity is desired, select the corresponding multiplier from Table 1, or use the equation in Step 4 to

determine the multiplier for a different intensity. Replace the multiplier in the pattern editor with the new value.

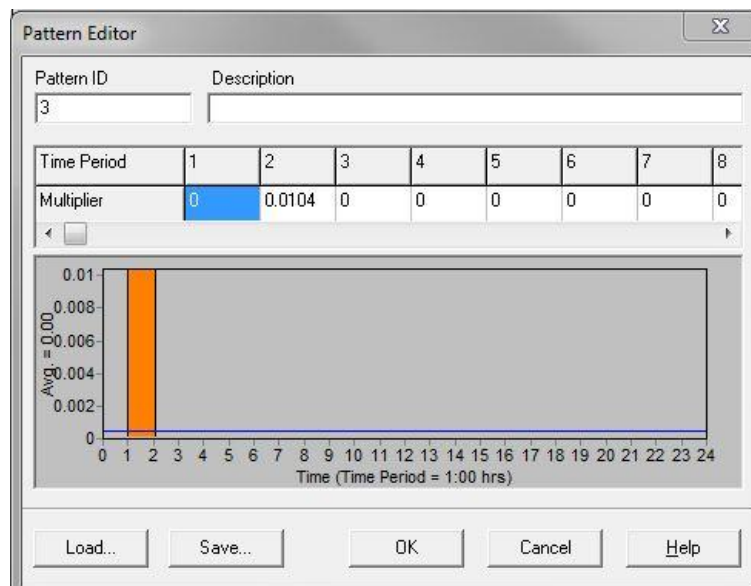
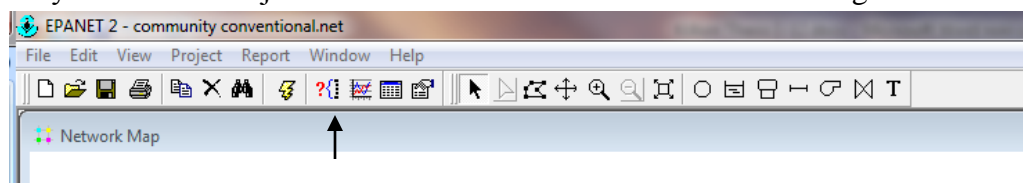

**Figure 3. Pattern editor for Rain Harvest Model.**

- The length of storm can also be changed. The minimum length of a storm is 1 hour, and the time step is 1 hour. If a two hour storm is desired, place the multiplier in 2 adjoining columns. Be sure that the “Time Period” given at the bottom of the graph is always 1 hour. Remember to rerun the model after changing the multiplier to receive the updated results.

## Community

- Open the EPANET software. Then open one of the community models ([Community Conventional](#), [Community Potable](#), or [Community Reclaimed](#)).
- To run the model click on the lightning bolt icon along the toolbar or click “Run Analysis” under “Project” above the toolbar. See arrow below in Figure 1.



**Figure 1. Location of icon to run EPANET.**

- The simulation runtime can be changed in the “Browser” window, under the “Data” tab by selecting “Options” as shown in Figure 2 below.



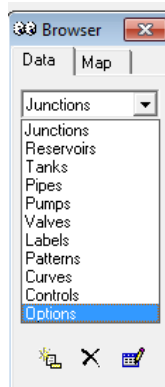

**Figure 2. Selecting “Options” in the “Browser” window to change the time of simulation.**

4. Under the options menu select “Times.” The window shown in Figure 3 will appear. From this window, the duration of the simulation can be changed as well as the hydraulic and reporting time steps. The pattern time step should not be changed.

Property	Hrs:Min
Total Duration	10
Hydraulic Time Step	0:01
Quality Time Step	0:05
Pattern Time Step	1:00
Pattern Start Time	0:00
Reporting Time Step	0:01
Report Start Time	0:00
Clock Start Time	12 am
Statistic	None

**Figure 3. “Time Options” menu in EPANET.**

5. Node and pipe properties are displayed by double clicking on the node or pipe of interest.
6. To view the various properties of the pipe throughout the simulation, click on the “Map” tab in the “Browser” window as shown below in Figure 4. The browser window opens with the program. It can also be launched by clicking “Window” above the toolbar and selecting “Browser.” One parameter can be selected for nodes and links in the system. A specific time can also be investigated. To start the real-time viewing of the simulation, click the forward arrow. The speed of the duration can be controlled using the slider at the bottom of the window.

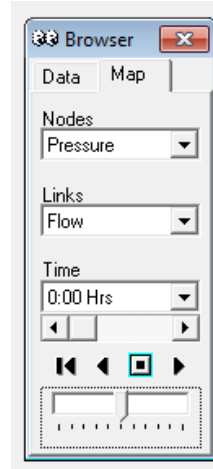

**Figure 4. Map tab in EPANET Browser window.**

7. To graph the parameter of interest for a node, pipe, or group of similar objects. Click the graph button shown in Figure 5. Once the new window opens select the node(s) or pipe(s) of interest and click add. The graph type and parameter of interest are also selected in this window. Click “OK” to create the graph.

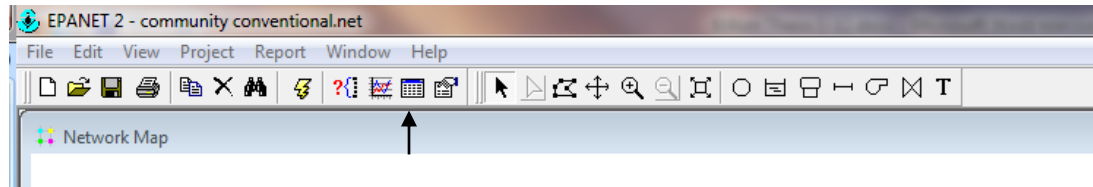

**Figure 5. Location of icon to graph node or pipe parameters in EPANET.**

8. The pump and elevated storage are controlled by rule-based controls. The rule-based controls are accessed under the controls menu as shown in Figure 6 below.

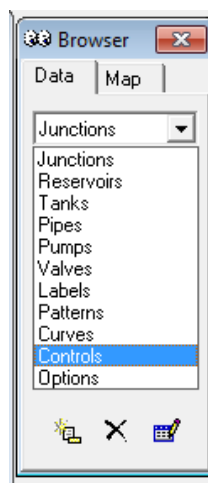

**Figure 6. EPANET Browser window to launch rule-based controls editor.**

9. The demands at the nodes are modeled using the base demands listed in the node characteristics window (found by double clicking on the node) and a pattern. The pattern for the residential and apartment nodes represents the typical diurnal use pattern. For businesses, the pattern is constant throughout the day. The base demand can be changed on the node characteristics window and the pattern can be changed by clicking on “Patterns” in the “Browser” window as in Figure 7. The multiplier in the patterns editor is multiplied by the base demand to give the actual demand.

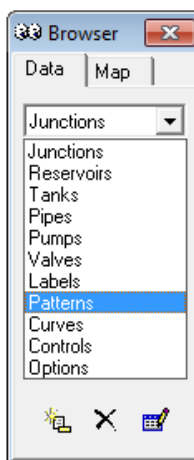

**Figure 7. Accessing Patterns editor in EPANET 2.**

The patterns used in the community models are outlined Table 1.

**Table 1. Description of patters used in EPANET 2 for Community Models**

Pattern ID	Description
1	Peak Residential Demand Pattern (The multipliers are different for the conventional, potable, and reclaimed models)
1-Ave	Average Residential Demand Pattern (The multipliers are different for the conventional, potable, and reclaimed models)
LI	Residential Lawn Irrigation (Only in conventional and reclaimed models)
1500	Fire Flow of 1500 gpm for 2 hours (Only in conventional and reclaimed models)
2400	Fire Flow of 2400 gpm for 2 hours (Only in conventional and reclaimed models)
LIApart	Apartment Lawn Irrigation (Only in conventional and reclaimed models)
NR	Peak Non-Residential Demand Pattern (Multiplier is always 1)
NR-Ave	Average Non-Residential Demand Pattern

10. The patterns for the peak flow rates are the default when a community file is opened. To switch to the average flow rates, double-click on the pattern for the peak flow in the “Browser” window. The “Pattern Editor” will appear. See Figure 8. In the “Pattern ID” box type “1-Peak”. Click “OK”. A “Confirm” window will appear, click “No”. Then, double click “1-Ave” in the “Browser” window for patterns. A window similar to Figure 8 will appear. This time, in the “Pattern ID” box type “1”. Once again, click “No” when the “Confirm” window appears. Now, the model will use the average flow rates for the residential nodes the next time the model is run. Repeat this process for the non-residential nodes. To change back to the peak flow rates reverse the process.

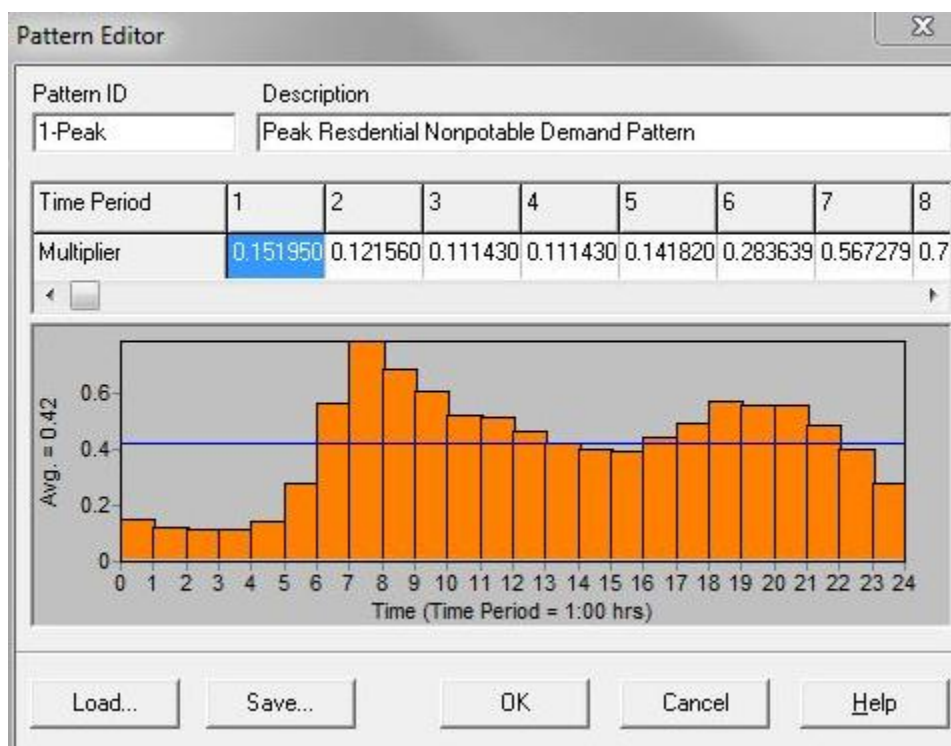

**Figure 8. Pattern Editor for Changing Between Peak and Average Flow Rates**

11. To convert the Conventional and Reclaimed Community models to average day flow rates, the irrigation must be reduced. The irrigation demand is reduced by decreasing the number of residential nodes irrigating. In the peak flow rate scenario all of the residential nodes and apartment buildings are irrigating. To change the irrigation status of a node, double-click the node of interest. A window similar to the one in Figure 9 will appear.

Property	Value
*Junction ID	112
X-Coordinate	-1720.34
Y-Coordinate	5000.00
Description	
Tag	7
*Elevation	1264
Base Demand	0.7
Demand Pattern	1
Demand Categories	2
Emitter Coeff.	
Initial Quality	
Source Quality	
Actual Demand	0.35
Total Head	1553.89
Pressure	125.61
Quality	0.00

**Figure 9. Node characteristics window in EPANET.**

12. Once the node characteristics menu is open, click on “Demand Categories.” After clicking, an ellipse should show appear as in Figure 9. Click on the ellipse. The window shown in Figure 10 will appear. Junction 112 has currently has two demands, the residential demand and an irrigation demand. Delete both the “0.1” and “LI” and click ok. The irrigation demand for node 112 is removed. Repeat this step until the desired number of nodes are irrigating.

	Base Demand	Time Pattern	Category
1	0.7	1	
2	0.1	LI	
3			
4			
5			
6			

**Figure 9. List of demands applied to a node in EPANET.**

13. To add a fire demand to the Reclaimed or Conventional Community models, open the “Demand for Junction” window for the node of interest as shown in Figure 9. Next, input “1” in row three of the “Base Demand” column and “1500” in row three of the “Time Pattern” column. Once the data has been entered click “OK” and rerun the model. A fire flow of 1500 gpm is used at all nodes except for nodes 68 and 104 which require a fire flow of 2400 gpm.

**Appendix B Square Footage of Apartment Roof Catchment Areas**

768.3	768.3																		768.3
1586.5	1586.5																		1586.5
1534.1	1534.1																		1534.1
1395.9	1395.9																		1395.9
1534.1	1534.1																		1534.1
1000.9	1000.9																		1000.9
1533.5																			1529
1001.5	4894.6																		4894.6
3421.6	998.8	1401.4	1534.1	1000.9	1534.1	1001	1997.8	1001	1534.1	1000.9	1534.1	1001	1997.8	1001	1534.1	1000.9	1534.1	1401.4	1000.8
																			3421.8

**Figure B.1 Roof subcatchments per collection nodes (ft<sup>2</sup>) for apartment building.**

**Appendix C Diagrams for the Number of Downspouts Required per  
Apartment Catchment**



1	1																1	1	1
1	1																1	1	1
1	1																1	1	1
1	1																1	1	1
1	1																1	1	1
1	1																1	1	1
1	1																1	1	1
1	3			1		1	1	1		1		2	1	1	1	1	3		1
2	1	1	1	1	1	1	1	1	1	1	2	1	1	1	1	1	1	1	2

**Figure C.1 The Number of Downspouts Needed per Drainage Area in Seattle for the Apartment Building. A total of 62 downspouts are needed.**



1		1																		1	1			
1		1																			1	1		
1		1																			1	1		
1		1																			1	1		
1		1																			1	1		
1		1																			1	1		
1		1																			1	1		
1		2				1		1	1	1	2	1	1	1	1	1	1	1	1			2	1	
1	1	1			1	1	1	1	1	1	2	1	1	1	1	1	1	1	1	1			1	1

**Figure C.3 The Number of Downspouts Needed per Drainage Area in Omaha for the Apartment Building. A total of 58 downspouts are needed.**

1	1																	1
1	1																	1
1	1																	1
1	1																	1
1	1																	1
1	1																	1
1	2		1	1	1	1	1	1	1	2	1	1	1	1	1		2	1
1	1	1	1	1	1	1	1	1	1	2	1	1	1	1	1	1	1	1

**Figure C.4 The Number of Downspouts Needed per Drainage Area in Tampa for the Apartment Building. A total of 58 downspouts are needed.**

**Appendix D Diagram of Apartment Building with All Plumbing Shown**

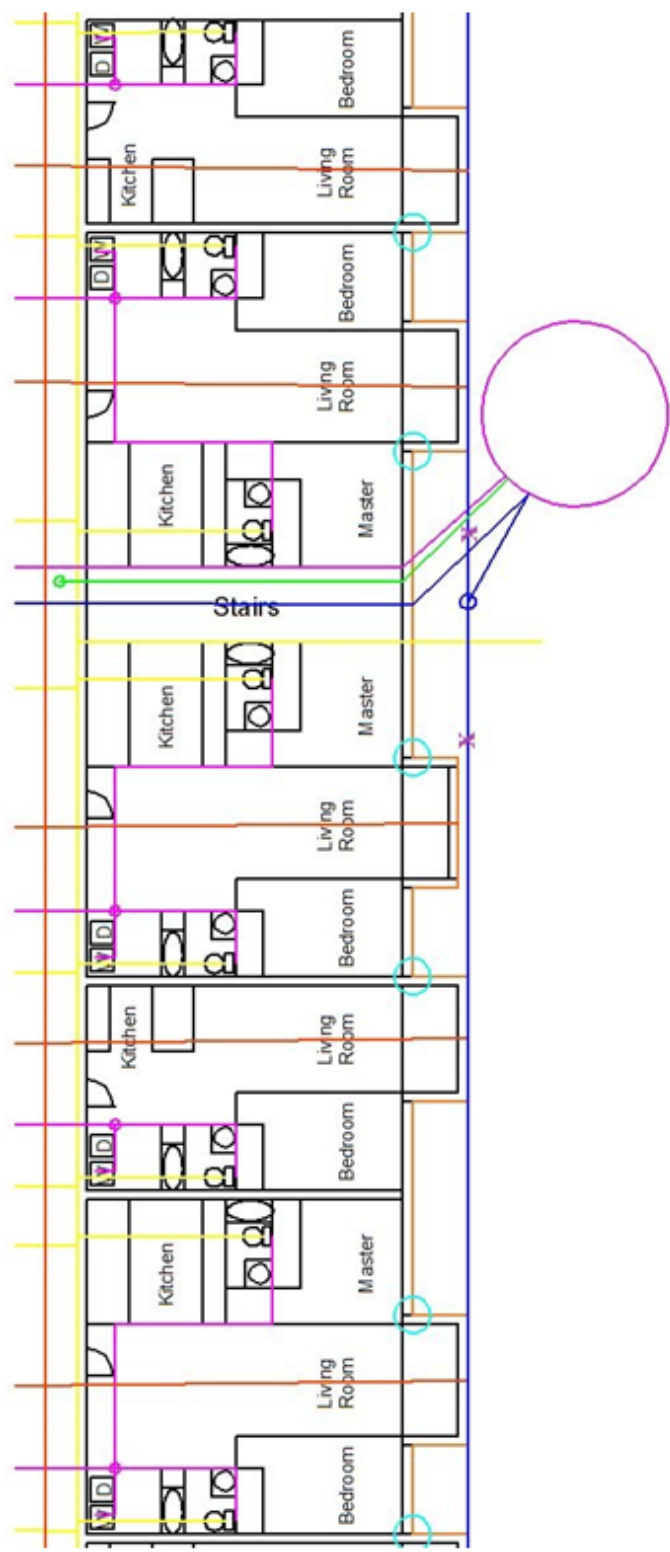

**Figure D.1 Example of Plumbing Layout for Apartment Rainwater Harvesting and Indoor Use.** Rainwater is harvested from the roof and stored in the cistern. The water is used inside for non-potable uses such as toilet flushing and laundry.

- Key: Purple Lines: Rainwater return lines to toilets and clothes washers
- Purple X's: Location of first flush diverters
- Purple Circle: Rainwater cistern
- Blue Lines: Underground rainwater collection system
- Light Blue Circles: Location of downspouts
- Green Line: Potable backup connection to tank
- Yellow Lines: Wastewater lines
- Brown Lines: Roof catchment subdivision

## **Appendix E Residential Water Use Pattern**

**Table E.1 Residential Water Use Patterns**

<b>Time</b>	<b>Hour</b>	<b>Hourly Percentage of Total Use*</b>
1:00 AM	1	1.5
2:00 AM	2	1.2
3:00 AM	3	1.1
4:00 AM	4	1.1
5:00 AM	5	1.4
6:00 AM	6	2.8
7:00 AM	7	5.6
8:00 AM	8	7.8
9:00 AM	9	6.8
10:00 AM	10	6
11:00 AM	11	5.2
12:00 PM	12	5.1
1:00 PM	13	4.6
2:00 PM	14	4.2
3:00 PM	15	4
4:00 PM	16	3.9
5:00 PM	17	4.4
6:00 PM	18	4.9
7:00 PM	19	5.7
8:00 PM	20	5.5
9:00 PM	21	5.5
10:00 PM	22	4.8
11:00 PM	23	4
12:00 AM	24	2.8

\*Average of all five study cities.

(AWWARF 1993)



## **Appendix F EPANET Pattern Multipliers for Community Models**

**Table F.1 EPANET 2 Multiplier for Conventional System**

Time	Hour	Hourly Percentage of Total Use*	Peak Demand 10 House Node = 2010.6 gpd		Average Demand 10 House Node = 1117.0 gpd	
			gph	gpm**	gph	gpm**
1:00 AM	1	1.5	30.16	0.50	16.76	0.28
2:00 AM	2	1.2	24.13	0.40	13.40	0.22
3:00 AM	3	1.1	22.12	0.37	12.29	0.20
4:00 AM	4	1.1	22.12	0.37	12.29	0.20
5:00 AM	5	1.4	28.15	0.47	15.64	0.26
6:00 AM	6	2.8	56.30	0.94	31.28	0.52
7:00 AM	7	5.6	112.60	1.88	62.55	1.04
8:00 AM	8	7.8	156.83	2.61	87.13	1.45
9:00 AM	9	6.8	136.72	2.28	75.96	1.27
10:00 AM	10	6	120.64	2.01	67.02	1.12
11:00 AM	11	5.2	104.55	1.74	58.08	0.97
12:00 PM	12	5.1	102.54	1.71	56.97	0.95
1:00 PM	13	4.6	92.49	1.54	51.38	0.86
2:00 PM	14	4.2	84.45	1.41	46.91	0.78
3:00 PM	15	4	80.43	1.34	44.68	0.74
4:00 PM	16	3.9	78.41	1.31	43.56	0.73
5:00 PM	17	4.4	88.47	1.47	49.15	0.82
6:00 PM	18	4.9	98.52	1.64	54.73	0.91
7:00 PM	19	5.7	114.61	1.91	63.67	1.06
8:00 PM	20	5.5	110.58	1.84	61.44	1.02
9:00 PM	21	5.5	110.58	1.84	61.44	1.02
10:00 PM	22	4.8	96.51	1.61	53.62	0.89
11:00 PM	23	4	80.43	1.34	44.68	0.74
12:00 AM	24	2.8	56.30	0.94	31.28	0.52

\*(AWWARF 1993)

\*\*The gpm flow rates become the EPANET multiplier

**Table F.2 EPANET 2 Multiplier for Non-Potable Portion of Dual Water System**

Time	Hour	Hourly Percentage of Total Use*	Peak Demand 10 House Node = 607.8 gpd		Average Demand 10 House Node = 337.7 gpd	
			gph	gpm**	gph	gpm**
1:00 AM	1	1.5	9.12	0.15	5.06	0.08
2:00 AM	2	1.2	7.29	0.12	4.05	0.07
3:00 AM	3	1.1	6.69	0.11	3.71	0.06
4:00 AM	4	1.1	6.69	0.11	3.71	0.06
5:00 AM	5	1.4	8.51	0.14	4.73	0.08
6:00 AM	6	2.8	17.02	0.28	9.45	0.16
7:00 AM	7	5.6	34.04	0.57	18.91	0.32
8:00 AM	8	7.8	47.41	0.79	26.34	0.44
9:00 AM	9	6.8	41.33	0.69	22.96	0.38
10:00 AM	10	6	36.47	0.61	20.26	0.34
11:00 AM	11	5.2	31.61	0.53	17.56	0.29
12:00 PM	12	5.1	31.00	0.52	17.22	0.29
1:00 PM	13	4.6	27.96	0.47	15.53	0.26
2:00 PM	14	4.2	25.53	0.43	14.18	0.24
3:00 PM	15	4	24.31	0.41	13.51	0.23
4:00 PM	16	3.9	23.70	0.40	13.17	0.22
5:00 PM	17	4.4	26.74	0.45	14.86	0.25
6:00 PM	18	4.9	29.78	0.50	16.55	0.28
7:00 PM	19	5.7	34.64	0.58	19.25	0.32
8:00 PM	20	5.5	33.43	0.56	18.57	0.31
9:00 PM	21	5.5	33.43	0.56	18.57	0.31
10:00 PM	22	4.8	29.17	0.49	16.21	0.27
11:00 PM	23	4	24.31	0.41	13.51	0.23
12:00 AM	24	2.8	17.02	0.28	9.45	0.16

\*(AWWARF 1993)

\*\*The gpm flow rates become the EPANET multiplier

**Table F.3 EPANET 2 Multiplier for Potable Portion of Dual Water System**

Time	Hour	Hourly Percentage of Total Use*	Peak Demand 10 House Node = 1402.8 gpd		Average Demand 10 House Node = 779.4 gpd	
			gph	gpm**	gph	gpm**
1:00 AM	1	1.5	21.04	0.35	11.69	0.19
2:00 AM	2	1.2	16.83	0.28	9.35	0.16
3:00 AM	3	1.1	15.43	0.26	8.57	0.14
4:00 AM	4	1.1	15.43	0.26	8.57	0.14
5:00 AM	5	1.4	19.64	0.33	10.91	0.18
6:00 AM	6	2.8	39.28	0.65	21.82	0.36
7:00 AM	7	5.6	78.56	1.31	43.64	0.73
8:00 AM	8	7.8	109.42	1.82	60.79	1.01
9:00 AM	9	6.8	95.39	1.59	53.00	0.88
10:00 AM	10	6	84.17	1.40	46.76	0.78
11:00 AM	11	5.2	72.95	1.22	40.53	0.68
12:00 PM	12	5.1	71.54	1.19	39.75	0.66
1:00 PM	13	4.6	64.53	1.08	35.85	0.60
2:00 PM	14	4.2	58.92	0.98	32.73	0.55
3:00 PM	15	4	56.11	0.94	31.17	0.52
4:00 PM	16	3.9	54.71	0.91	30.39	0.51
5:00 PM	17	4.4	61.72	1.03	34.29	0.57
6:00 PM	18	4.9	68.74	1.15	38.19	0.64
7:00 PM	19	5.7	79.96	1.33	44.42	0.74
8:00 PM	20	5.5	77.16	1.29	42.86	0.71
9:00 PM	21	5.5	77.16	1.29	42.86	0.71
10:00 PM	22	4.8	67.34	1.12	37.41	0.62
11:00 PM	23	4	56.11	0.94	31.17	0.52
12:00 AM	24	2.8	39.28	0.65	21.82	0.36

\*(AWWARF 1993)

\*\*The gpm flow rates become the EPANET multiplier

## **Appendix G Design Guides for Water Reuse**

## **INTRODUCTION**

The purpose of the Water Reuse Design Guide is to help designers design reuse systems that are effective, low maintenance and easy to install. The information in this guide is relevant to everyone interested in water reuse with a focus on individual homeowners. The goal of this design guide is to promote water reuse as part of the solution to sustainable water use.

Water reuse focuses on treating water to the level required for the end use instead of treating all water to potable quality regardless of the use. Implementing an effective water reuse program will reduce the potable water demand. Lowering the potable water demand reduces negative environmental impacts associated with water treatment and distribution. When greywater is reused, the treatment volume at the wastewater treatment plants is also reduced. Reducing demands on water and wastewater treatment plants helps to extend their operational life and to delay the building of additional treatment facilities.

Water reuse also addresses the issue of water scarcity. Instead of relying on fresh water withdrawals to meet the entire demand of a building, greywater, and/or rainwater can be used to meet the non-potable demands. As a result, water reuse will also reduce fresh water withdrawals. In this guide, the basics of greywater reuse and rainwater harvesting will be analyzed, and additional relevant resources will be given.

### **Determining Water Reuse Goals**

The most important step in water reuse is determining the water reuse goals. The goal for one homeowner may be to use untreated greywater for subsurface irrigation. Another homeowner may want to use treated greywater for toilet flushing and clothes washing. The systems required for the two scenarios are very different. Therefore, the end goals must be determined before designing a water reuse system.

Some example end-use goals are to use greywater, or rainwater water for:

- Subsurface irrigation
- Sprinkler irrigation
- Toilet flushing
- Clothes washing

### **Dual Distribution**

In order to implement a water reuse program, a dual distribution system is required. Dual distribution means that there are two separate pipe networks. The additional network is needed to keep water of varying qualities separated so no cross contamination occurs. For example, in a greywater system, greywater collected from

sinks and showers must be separated from the blackwater collected from toilets. It must also be separated from the potable water system.

### Indoor Water Demands

The flow rates for each indoor plumbing fixture are listed in Table 1. Both conventional and high efficiency flow rates are given. The typical indoor per capita flow rates are given in Table 2.

**Table 1. Conventional and High Efficiency Flow Rates for Indoor Plumbing**

Fixture	Conventional Rates*		High Efficiency Rates		References for High Efficiency Rates
	gal	l	gal	l	
<b>Toilet</b> (per flush)	3.48	13.17	1.3	4.92	(USGBC 2008)
<b>Shower and Bath</b> (per minute)	2.22	8.40	2.0	7.57	(USGBC 2008)
<b>Clothes Washer</b> (per load)	40.9	154.82	14.85	56.21	(USGBC 2008; California Energy Commission 2010)
<b>Faucet</b> (per minute)	1.34	5.07	1.34	5.07	(Mayer et al. 1999)
<b>Dishwasher</b> (per load)	10	37.85	5.8	21.96	(USEPA and U.S. Department of Energy )

\*Adapted from: (Mayer et al. 1999)

**Table 2. Typical Per Capita Indoor Flow Rates**

Fixture	Conventional Fixtures		High Efficiency Fixtures	
	gpcd	lpcd	gpcd	lpcd
Bathroom faucet	2.97	11.24	2.96	11.20
Clothes washer	15.0	56.78	5.49	20.78
Dishwasher	1.0	3.79	0.57	2.16
Kitchen faucet	7.93	30.02	7.89	29.87
Shower/Bath	12.8	48.45	16.40	62.08
Toilet	18.5	70.03	6.57	24.87

Adapted from: (Mayer et al. 1999)

## Reclaimed Water Quality

The Environmental Protection Agency (EPA) has developed guidelines for water reuse. The manual gives the water quality required for certain uses of reclaimed water by several states. The guidelines for unrestricted water use are given in Table 3.

**Table 3. State Guidelines for Unrestricted Reclaimed Water Use.**

Parameter	Arizona	California	Florida	Hawaii	Nevada	Texas	Washington
Treatment	Secondary treatment, filtration and disinfection	Oxidized coagulated, filtered, and disinfected	Secondary treatment, filtration, and high-level disinfection	Oxidized, filtered, and disinfected	Secondary treatment and disinfection	NS*	Oxidized, coagulated, filtered, and disinfected
BOD <sub>5</sub>	NS	NS	20 mg/l CBOD <sub>5</sub>	NS	30 mg/l	5 mg/l	30 mg/l
TSS	NS	NS	5.0 mg/l	NS	NS	NS	30 mg/l
Turbidity	2 NTU (Avg)	2 NTU (Avg)	NS	2 NTU (Max)	NS	3 NTU	2 NTU (Avg)
	5 NTU (Max)	5 NTU (Max)					5 NTU (Max)
Coliform	Fecal	Total	Fecal	Fecal	Fecal	Fecal	Total
	Non detectable (Avg)	2.2/100 ml (Avg)	75% of samples below detection	2.2/100 ml (Avg)	2.2/100 ml (Avg)	20/100 ml (Avg)	2.2/100 ml (Avg)
	23/100 ml (Max)	23/100 ml (Max in 30 days)	25/100 ml (Max)	23/100 ml (Max in 30 days)	23/100 ml (Max)	75/100 ml (Max)	23/100 ml (Max)

\*NS-Not Specified  
(USEPA 2004)

## GREYWATER SYSTEMS

Greywater systems are based on reusing lightly contaminated water from the house such as water from showering and hand washing. A study in Australia reported a 20.0% to 32.5% reduction in potable water use when greywater was used for lawn irrigation and toilet flushing. Likewise, wastewater totals were reduced by 33.2% to 54.1% by implementing greywater reuse (Zhang et al. 2010).

### Greywater Sources

Greywater is defined as the wastewater from all household sources except for toilets (Christova-Boal et al. 1996; Ludwig 2009). The definition is commonly restricted to include only human washing operations such as baths, showers, and bathroom sinks (Jefferson et al. 2004; Ludwig 2009). Other authors also include laundry water in the definition of greywater (Christova-Boal et al. 1996; Al-Jayyousi 2003). The greywater definition used by the National Standard Plumbing Code (2006) is “used untreated water



generated by clothes washing machines, showers, bathtubs and lavatories. It shall not include water from kitchen sinks or dishwashers.”

### Greywater Quality

Several studies report that greywater must be treated as dilute sewage because it contains all of the components of raw wastewater (Christova-Boal et al. 1996). Greywater itself typically contains low levels of fecal contamination, but several studies have reported high levels of fecal indicators. In some instances, the quantity of fecal indicators was in the range associated with raw wastewater (Alkhatib et al. 2006). Other sources report greywater being relatively free of organic matter, pathogens, and trace constituents (Asano 2007).

The quality of greywater is highly dependent on the quality of the water supply, the piping network, and the activities in the home. The piping network can affect the quality of water because of leaching from the pipe, and biological and chemical processes occurring in the biofilm on the pipe walls. The most important determinations of the quality are the lifestyle, installations, and chemicals used in the household (Eriksson et al. 2002). Table 4 below lists the characteristics of greywater from various sources.

**Table 4. Typical Characteristics of Greywater**

Parameter	(Christova-Boal et al. 1996)		(Surendran et al 1998) grab samples		
	Bathroom water range <sub>1</sub>	Laundry water range <sub>1</sub>	Bath/shower <sub>1</sub>	Wash Basin <sub>1</sub>	Washing Machine <sub>1</sub>
Aluminium	<1.0	<1.0-2.1			
Ammonia, as N	<0.1-15	<0.1-1.9	1.56	0.53	10.7
Arsenic, as AS	0.001	0.001-0.007			
Azure A active substances	1.2-10	30-150			
BOD <sub>5</sub> /d	76-200	48-290	216	252	472
Cadmium, as Cd	<0.01	<0.01	0.54	-	0.63
Calcium	3.5-7.9	3.9-12			
Chloride, as Cl	9.0-18	9.0-88			
COD			424	433	725
Colour, Pt/Co units	60-100	50-70			
Copper	0.06-0.12	<0.05-0.27	111	-	322
Dissolved solids			559	520	590
EC 25°C, µS/cm	82-250	190-1400			
Fecal coliforms/100 mL	MPN 170-3.3E3	MPN 110-1.09E3	600 cfu	32 cfu	728 cfu
Fecal streptococci/100mL	MPN 79-2.4E3	MPN 23-2.4E3			
Inorganic carbon			26	20	25
Iron	0.34-1.1	0.29-1.0			
Lead			3	-	33

Parameter	Bathroom water range <sub>1</sub>	Laundry water range <sub>1</sub>	Bath/shower <sub>1</sub>	Wash Basin <sub>1</sub>	Washing Machine <sub>1</sub>
Magnesium	1.4-2.3	1.1-2.9			
Nitrate and nitrite as N	<0.05-0.20	0.10-0.31	0.9	0.34	1.6
Oil and grease	37-78	8.0-35			
pH	6.4-8.1	9.3-10	7.6	8.1	8.1
Phosphate as P			1.63	45.5	101
Phosphorus, total as P	0.11-1.8	0.062-42			
Potassium	1.5-5.2	1.1-17			
Selenium, as SE	<0.001	<0.001			
Silicon	3.2-4.12	3.8-49			
Sodium	7.4-1.8	49-480			
Sulfur	1.2-3.3	9.5-40			
Suspended solids	48-120	88-250	76	40	68
Total alkalinity, as CaCO <sub>3</sub>	24-43	83-200			
Total coliforms/100 mL	MPN 500-2.4E7	MPN 2.3E3-3.3E5	6E6 cfu	5E4 cfu	7E5 cfu
Total Kjeldahl nitrogen, as N	4.6-20	1.0-40			
Total organic carbon			104	40	110
Total solids			631	558	658
Turbidity,NTU	60-240	50-210	92	102	108
Volatile solids			318	240	330
Zinc	0.2-6.3	0.09-0.32	59	-	308

<sub>1</sub> Units in mg/L unless otherwise noted.

### Greywater Treatment

Untreated greywater contains soaps, detergents, dirt from laundry, and organic matter and pathogens from human bodies (Novotny et al. 2010). When compared to toilet wastewater, greywater has fewer pathogens and 90% less nitrogen. Greywater treatment is less expensive and requires less energy than wastewater treatment because of lower solids loading rates, BOD loading, and lower microbial content (Sheikh 2010; Ishida et al. 2009). As a result, greywater treatment is cheaper and less complex than standard wastewater treatment (Asano 2007; Zhang et al. 2010). Common greywater treatment systems include modified sand filters, constructed wetlands, biological systems such as membrane bioreactors (MBR), and biologically aerated filters (Zhang et al. 2010). The current regulations for greywater are not dependent on health risk data such as pathogen dose-response, but are instead based on the perceived risk (Ishida et al. 2009).

### Greywater Quantities

Approximately, 50-80% of household wastewater is greywater (Novotny et al. 2010; Eriksson et al. 2003). Limiting the definition of greywater to include water from

showers, baths, laundry, and bathroom sinks, the amount of greywater produced can be determined from the data presented in Table 5.

**Table 5. National Average of Greywater Production Broken Down by Fixture.**

Fixture	Amount	
	gpcd	lcpd
Toilet	6.57	24.87
Shower	16.40	62.08
Clothes washer	5.49	20.78
Faucet	10.85	41.07
Total Greywater Production	39.31	148.80

Source: (Mayer et al. 1999).

Note: Faucet amount includes both kitchen and bathroom faucets.

A breakdown of greywater production in the United States is shown in Figure 1. The faucet use is overestimated in Table 5 and Figure 1 as it includes both the kitchen and bathroom sinks. The average greywater production from the bathroom sink is 3 gpd (11.4 lpd).

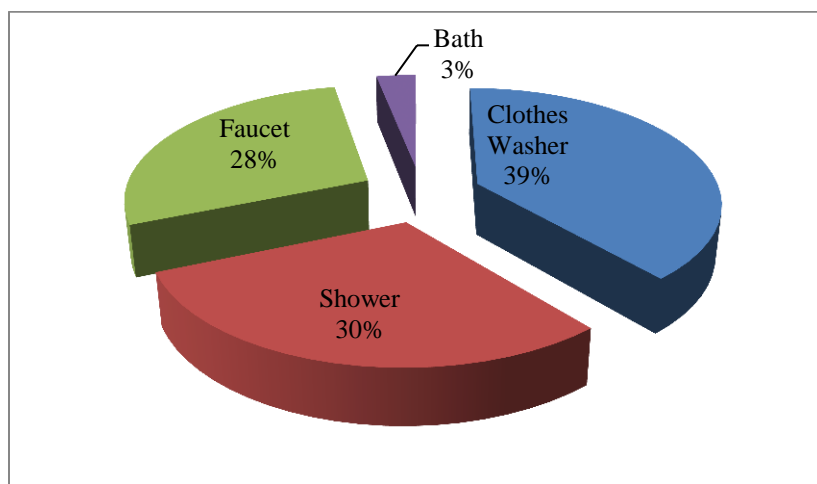

Adapted from: (Mayer et al. 1999)

**Figure 1. Breakdown of Greywater Production in the United States.**

The value for the faucet includes both the kitchen and bathroom faucets.

### Greywater Uses

Many uses exist for greywater, but they are heavily dependent on the quality of greywater and the amount of treatment it has received. Essentially, greywater can be used for any purpose as long as it is treated to meet the appropriate standards (Li et al. 2009). Two common uses for greywater are toilet flushing and garden watering (Christova-Boal

et al. 1996). Other uses are laundry, window, and vehicle washing, fire protection, boiler feed water, and concrete production (Eriksson et al. 2003). Untreated greywater can be used for subsurface irrigation (Zhang et al. 2010; Christova-Boal et al. 1996; Ludwig 2009).

### **Health Concerns Associated with Greywater Use**

The impact of greywater on human health depends on the pathogen source and the exposure routes. Health concerns associated with greywater reuse include the possibility of spreading diseases because of microorganisms in the water. Possible transmission pathways include direct contact with greywater, and irrigation (Ottoson and Stenstrom 2003). For example, if the water is used for toilet flushing, it is possible that contaminants in the water can become aerosols (Ludwig 2009; Eriksson et al. 2002).

Most of the health concerns associated with greywater can be avoided by using proper precautions. The first is to design the greywater system so no human-to-greywater contact occurs. The greywater should also percolate through topsoil for natural purification to occur. Washing hands after contact with greywater or wearing gloves when cleaning greywater filters helps to protect from ingesting any microorganisms that might be present. Likewise, untreated greywater should not be applied directly to lawns, or vegetables and fruits that are eaten raw (Ludwig 2009). No cases of greywater-transmitted illness have been documented in the United States, and taking precautions such as the ones listed above will help to avoid any potential illnesses occurring from greywater (Ludwig 2009; Sheikh 2010).

### **Design Considerations**

If untreated greywater is used for subsurface irrigation, it is important to be mindful about the type of cleaning supplies and other chemicals used in the home. Chemicals used in the sink, shower, etc. will end up in the subsurface irrigation system and may have harmful effects on the vegetation.

Along with determining the goals of the greywater system, the greywater production must also be calculated. The greywater quantity is dependent on the number of people in the building and what fixtures will contribute to the greywater. Some homeowners may want to include the kitchen sink and dishwasher to maximize greywater-recycling potential, while others may want to only utilize light greywater from the bathroom sinks, showers, and clothes washing to improve the quality of greywater used.

If irrigation with greywater is the goal, the irrigation requirement needs to be determined. A local nursery should be able to help estimate the irrigation demand in the given region. Knowledge of the irrigation demand will help determine the area that can be irrigated with greywater.

PVC pipe is commonly used for the greywater collection system; however ABS and HDPE can also be used. According to Ludwig (2009), HDPE is the most environmentally friendly plastic followed by ABS. Pipe diameters less than 1.5 inches (38 mm) should be avoided to prevent pipe clogging.

Greywater can be collected in a pipe system similar to the wastewater collection system, or water can be piped from each fixture directly outside. Ludwig (2009) describes the pros and cons of each system. One factor to consider when determining the type of system is the climate. If there is an irrigation demand year round a greywater system from the fixture directly outside may be the best solution. In a climate that experiences freezing, a more conventional greywater collection system that allows the greywater to be diverted to the wastewater system during months when there is no irrigation demand may be better.

Storage is another aspect of greywater systems that must be addressed. Untreated greywater should not be stored for more than 48 hours otherwise the biological activity of the water will cause odor and sanitation problems (Dixon et al. 1999). Storage is usually associated with a treatment system. A storage tank may be needed to equalize the flows entering a treatment unit. Once the water has been treated, it can be stored for longer periods of time, but the production and demand for treated greywater should be matched as closely as possible to minimize the storage time.

Some companies have developed greywater treatment units. Greywater enters the unit, where it is treated to the required levels. After treatment, the water is pumped through a separate distribution system to toilets and/or clothes washers. Refer to the websites listed under greywater resources for more information on these systems.

### **Design Process:**

1. Determine end-use goals.
  - What is the intended use for the greywater? Do you want to treat the greywater?
  - Subsurface irrigation generally does not required treatment. Most other uses currently do require treatment. Examples of some greywater uses are:
    - Subsurface irrigation (no treatment required)
    - Sprinkler irrigation (treatment required)
    - Toilet flushing (treatment required)
    - Clothes washing (treatment required)

The simplest system is to use untreated greywater for subsurface irrigation. In a warm climate, the water can be piped directly outside from each fixture as Ludwig explains (2009). Treating greywater requires more infrastructure (greywater collection and treated water distribution systems) and the use of a greywater

treatment unit. Typically, the more complex a system becomes the more expensive it is to implement and maintain.

2. Select greywater sources.

- Shower/bath, bathroom sinks, laundry machine, kitchen sink, dishwasher

Light greywater (water from bathroom sinks, laundry machine, and shower/bath) typically has a higher water quality. Water from dishwashers usually have poor water quality because of the quantity of solids, and high salt and pH from dishwashing soap. The kitchen sink water quality is better than the dishwasher, but it can cause problems in delicate systems because it is high in nutrients, solids, grease, and soap. However, the high nutrient levels can be beneficial to plants if the water is used for irrigation (Ludwig 2009).

3. Determine greywater quantities.

Greywater quantities can be determined using the following procedures:

- Multiply the values given in Table 1 by the number of times a toilet is flushed in the house each day, the number of minutes a shower or sink is used each day, etc. Keep track of the values for a couple weeks and then determine the average water use.
- Multiply the values given in Table 2 by the number of people in the building.
- Determine your own flow rates by looking at fixture specifications or by placing a volume-measuring device under the fixture and turn it on for a set amount of time. After the time has elapsed, measure the volume of water in the container and divide it by the time the water was running to obtain a flow rate. Then, monitor the amount of time each fixture is used over a few weeks and calculate how much water is used per day.

Regardless of the method used to calculate the flow rates, be sure to include only water from the sources selected in Step 2. When determining the greywater quantities, be sure to consider any seasonal variation that may occur. In some locations, irrigation is not required year round. In this situation, it is probably best to have a diverter valve to divert the greywater to the wastewater system. The number of showers or laundry cycles etc. might also increase or decrease during certain months. Make sure you identify any variations in water use or water demand when determining the greywater sources and end-uses.

4. Determine water demand for end-use goals.

For irrigation, speak with a local nursery to determine the water requirements for the vegetation to be irrigated. Calculate the water demand on a daily or weekly basis so it can be compared to the greywater quantities calculated in Step 3.

Another way to calculate the irrigation demand is to determine the evapotranspiration rates for the vegetation (Gardels 2011). Ludwig (2009) also gives estimates for irrigation demand.

If greywater treatment and indoor reuse is to be used, the values given in Table 1 and Table 2 can be used to calculate the demand.

5. Ensure greywater quantities from Step 2 and the end-use water demands from Step 4 match.

The amount of water produced and the amount of water required for the end-uses should match. If they do not, issues such as overwatering, or having to use another water source will arise. Additional greywater sources can be added or removed to meet the end-use demand. Likewise, the end-use demand can be decreased by reducing the size of area to be irrigated or reducing the number of fixtures supplied with treated greywater. Do not continue until the production and demand quantities are matched.

6. Design greywater collection system.

- Direct drain from fixtures to lawn  
HDPE can be used to directly link the drain of a sink, shower, etc. to the outdoors. A drain screen should be used to keep bugs from entering the home through the pipe. Pipe diameters less than 1 inch (25.4 mm) should not be used. For more details on how to install this system, refer to Ludwig (2009).
- Branched collection to subsurface irrigation  
ABS or PVC is connected to each drain chosen in Step 2. The pipe is then connected to one common pipe that exits the house. Pipe diameters less than 1.5 inches should be avoided to prevent clogging. The main pipe should also include a diverter valve to the wastewater pipe in the home. This allows the greywater to be diverted to the wastewater system when irrigation is not required or desired. An example collection system is shown below in Figure 2.

A dipper box and plastic dipper should be utilized to help prevent pipe clogging. Water enters the box and fills the plastic dipper. Once the dipper is full, it tips over and releases water into the pipes that go to the mulch basins for subsurface irrigation. The dipper box eliminates low velocities in the pipes and, therefore, reduces sedimentation in the pipes.

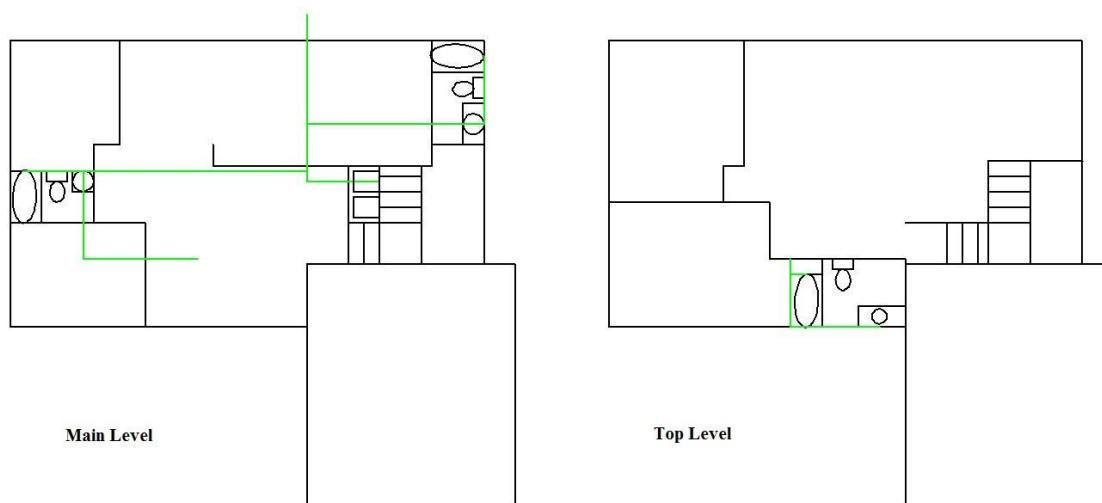

**Figure 2. Simple Greywater Collection System for Subsurface Irrigation.** The green lines represent the greywater collection pipe. The collection system starts in the upstairs bathroom and then connects to the main floor in the main bathroom.

In order for greywater to be used for irrigation without treatment, it must be delivered to the vegetation through the subsurface. The easiest way to accomplish this is to have the ABS or PVC pipe run to a mulch basin that has been created around the vegetation. A mulch basin is a depression that has been dug around the vegetation and is then filled with mulch. Mulch basins can have an island for plants that are not water loving or that have root rot issues. The plant is placed in the island, and the mulch is placed around the island.

- Greywater collection with treatment

The collection network for this system is similar to the branched collection system used for subsurface irrigation. The only difference is that instead of taking water out of the house, it is taken to a treatment location within the house. The best location for a treatment area is in a basement to allow for the collection system to drain by gravity. The water then drains into a greywater treatment system. Companies such as Brac Systems and Aqua 2 Use sell units that treat greywater. The treated greywater must meet the quality specified in Table 3 or other applicable state guidelines. A backup supply line from the potable system and an overflow line to the wastewater system are also required.

Once the greywater is treated, it must be redistributed throughout the house, or outdoors for surface irrigation. Redistribution requires the use of a pump. Some of the treatment units include a pump. If not, a local pump supplier can help you choose an appropriate pump. A pump and pressure



tank combination is suggested to keep the pump from short cycling. When only a small amount of water is used, the pressure tank supplies the flow without turning the pump on. When the pressure in the tank reaches the established minimum, the pump turns on and refills the pressure tank.

The easiest way to redistribute water to toilets, clothes washers, and/or a sprinkler irrigation system is to use cross-lined polyethylene (PEX). PEX is flexible tubing that is being used in new homes. It is more cost-effective than using copper plumbing for water. The pump or pressure tank connects to a manifold, which has an individual PEX line running to each point of use. An example collection and distribution system is given in Figure3.

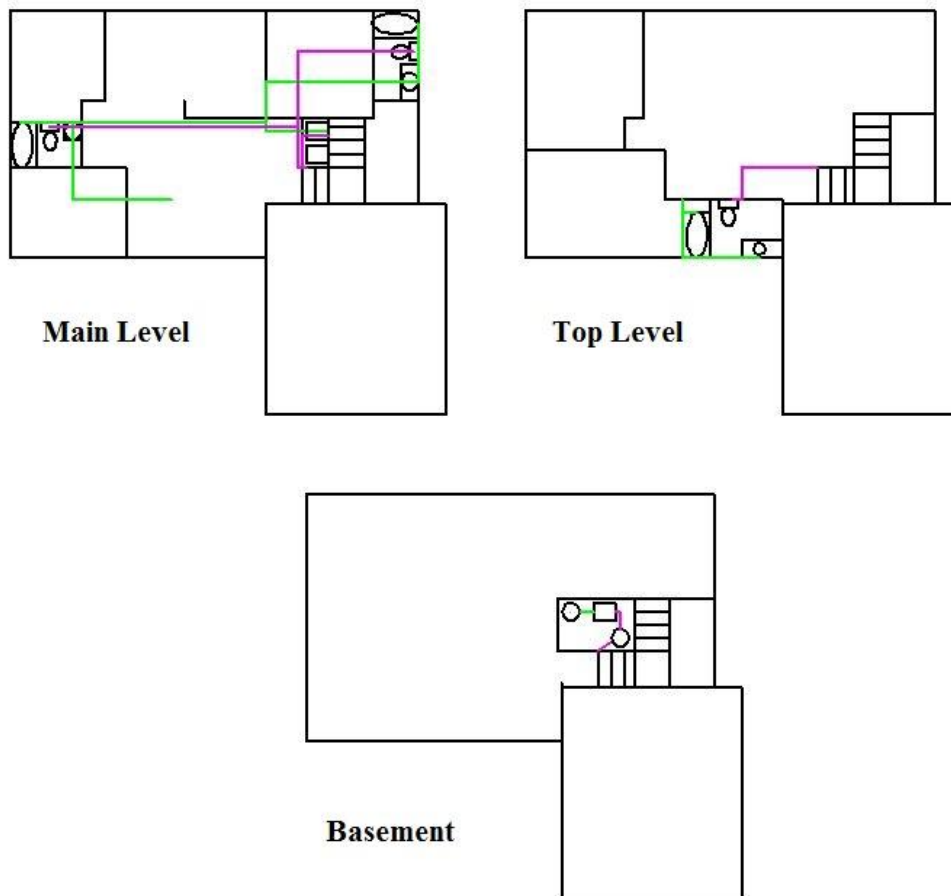

**Figure 3. Collection and distribution system for greywater treatment and indoor reuse.** The green lines are the greywater collection system and the purple lines are the treated greywater distribution system. Water is collected in the green pipes and transported to the greywater storage tank in the basement. The water is treated and then stored in another tank before being pumped into a pressure tank and distributed to the toilets and washing machine through the purple PEX pipes.

## 7. Greywater Storage

Most packaged greywater treatment units include storage based on the number of people in the building. To design storage independent of a packaged treatment system, follow the storage sizing guidelines outlined below.

Long-term storage of untreated greywater should be avoided if possible. After 48 hours, the water quality becomes poor and leads to odor and sanitation problems. It is better to store greywater after treatment than before. The amount of storage is dependent on the production of greywater, the treatment flow rate, and the end-use water demand. To size storage tanks, these rates should be measured over a typical week. Seasonal variation should also be taken into consideration. If more greywater is produced and consumed during a certain season, the system should be designed for the corresponding flow rates, while also ensuring that it can function properly at lower flow rates during the other seasons. In most scenarios, two storage tanks are needed. The first tank collects the greywater and feeds into a treatment tank. After the treatment tank, a second storage tank is used to store the treated greywater until it is used.

### **Storage for Untreated Greywater**

To size the untreated greywater storage tank, the greywater production rates and the treatment flow rates must be known. The treatment flow rate is usually constant. The difference between the production flow rate and treatment flow rate is the storage volume. Water can be wasted from the greywater storage tank through the overflow valve, if greywater production surpasses the available storage volume. Some treatment systems must always be filled with water. If this is the case, this constraint must be taken into consideration when sizing the storage tank.. A typical untreated greywater storage tank size for a single-family home is approximately 75-gallons.

### **Storage for Treated Greywater**

Storage for treated greywater is based on the flow rate from the treatment system and the demand for the treated water in the building. Wasting water from the treated storage tank should be avoided, although an overflow system to the wastewater system is required. Any water should be wasted from the untreated greywater storage tank if possible; this reduces the associated treatment costs. A backup line from the potable system must also be connected to the storage tank add supplemental water if the tank water level is low. A typical treated greywater storage tank size for a single-family home is 65 gallons.

## 8. Greywater Treatment

Common greywater treatment systems include modified sand filters, constructed wetlands, biological systems such as membrane bioreactors (MBR), and biologically aerated filters (Zhang et al. 2010). Generally at a minimum, most greywater must be filtered and disinfected before reuse. Disinfection can be achieved by chlorination or by using ultra-filtration membranes such as membrane bioreactors. Other disinfection methods such as ultraviolet light systems are also available. Further treatment such as nutrient removal may be needed depending on the end use of the treated greywater.

Greywater treatment units are commercially available. Details on some units commercially available are located under the Greywater Resources section.

### **Greywater Resources:**

#### Basic Greywater Information:

Ecology Center. <http://www.ecologycenter.org/factsheets/greywater.html>

Do it yourself subsurface greywater irrigation, installing greywater collection system, common errors to avoid when implementing greywater reuse:

Art Ludwig. Create an Oasis with Greywater: Choosing, Building, and Using Greywater Systems. Revised and Expanded Fifth Edition. 2009. Available from [www.oasisdesign.net](http://www.oasisdesign.net)

Greywater irrigation using a pump system:

Flotender. <http://www.flotender.com/>

Aqua 2 Use. <http://www.aqua2use.com/>

ReWater Systems. <http://rewater.com>

Greywater treatment for indoor reuse:

Aqua 2 Use. <http://www.aqua2use.com/>

Brac Systems. <http://www.bracsystems.com/>

Greywater from bathroom sink to toilet flush water:

AQUS® Greywater Recycling System. <http://www.watersavertech.com/AQUS-Water-Conservation.html>

Sloan Aquus System.

[http://www.sloanvalve.com/Water\\_Efficiency/AQUS\\_Greywater\\_Systems.aspx](http://www.sloanvalve.com/Water_Efficiency/AQUS_Greywater_Systems.aspx)

Selecting detergents and plants best suited for greywater harvesting, Arizona guidelines  
Harvesting Rainwater for Drylands and Beyond. Brad Lancaster.  
<http://www.harvestingrainwater.com/>

## RAINWATER SYSTEMS

Rainwater harvesting is not a new concept. It has been utilized in dry climates for thousands of years. Rainwater is a free water source with only treatment and storage costs. Harvesting of rainwater augments groundwater supplies by reducing the quantity of water withdrawn, and reduces stormwater runoff. In urban areas, rainwater harvesting reduces non-point pollution and erosion. Water collected from rainwater harvesting can be used for non-potable indoor uses. With proper treatment, the water can also be used for potable purposes. Rainwater harvesting is also generally more economical than expanding the public water supply (Aladenola and Adeboye 2010; Texas Water Development Board 2005). Combining widespread rainwater harvesting with other technologies has the potential to reduce greenhouse gas emissions by reducing the size of water storage reservoirs and reducing the quantity of water that needs to be treated (Aladenola and Adeboye 2010).

### Collection of Rainwater

Rainwater can be harvested from any surface. The most common system is roof-based collection. The amount of water that can be collected is dependent on the area of the roof, amount of rainfall, and storage capacity (Aladenola and Adeboye 2010; Texas Water Development Board 2005). Rainwater from residential roofs is considered safe for most residential uses (Zhang et al. 2010). An Australian study reported a savings of 12.3% to 25.1% in potable water use when harvested rainwater was used for toilet flushing and lawn irrigation. Residential use of rainwater in this study decreased the stormwater runoff by 23.4% to 48.1% (Zhang et al. 2010).

### Rainwater Quality

The quality of rainwater is impacted by the age and cleanliness of the catchments, gutters, pipes, and storage tanks as well as the atmospheric conditions. Maintenance of the rainwater harvesting system before storms greatly improves the water quality (Lee et al. 2010). A summary of typical rainwater quality parameters is listed in Table 6.

**Table 6. Rainwater Quality**

Parameter	(Appan 1999)	(Lee et al. 2010)	
	Rainwater <sub>1</sub>	Harvested Rainwater <sub>2</sub>	Rainwater <sub>2</sub>
pH	4.1 (0.4)	7.3 (6.7-7.8)	5.3 (4.3-6)
Colour	8.7 (9.9)		
Turbidity (NTU)	4.6 (5.7)		
TSS (mg/L)	9.1 (8.9)		
TDS (mg/L)	19.5 (12.5)	88 (40-230)	7.6 (3.4-52.1)
Hardness as CaCO <sub>3</sub> (mg/L)	0.1 (0.3)		
PO <sub>4</sub> as P (mg/L)	0.1 (0.6)		

Parameter	Rainwater <sub>1</sub>	Harvested Rainwater <sub>2</sub>	Rainwater <sub>2</sub>
Total coliform (MPN/100mL)	92.0 (97.1)	70 CFU/100 mL	ND <sub>3</sub>
Faecal coliform (MPN/100mL)	6.7 (8.9)		
Conductivity (µS/cm)		170 (50-340)	30 (50-340)
Nitrate (mg/L)		6.8 (2.9-9.8)	2.2 (0.6-4.2)
NH <sub>4</sub> <sup>+</sup> (mg/L)		0.09 (0.06-0.39)	0.02 (0.0-0.05)
Phosphate		0.02 (0-0.04)	ND
Chloride (mg/L)		7.5 (5-18)	3.0 (1.1-10)
Calcium (mg/L)		6.4 (3.24-15.4)	1.6 (0.17-3.82)
Magnesium (mg/L)		1.2 (0.5-2.7)	0.22 (0.04-0.62)
Sodium (mg/L)		3.2 (2.2-6.1)	1.1 (0.24-4)
Potassium (mg/L)		3.1 (1.3-5.9)	2.1 (0.16-6.5)
Sulfates (mg/L)		4.1 (2-7.2)	2.4 (1-6.2)
Mn (µg/L)		115 (70-170)	40 (20-80)
Pb (µg/L)		27 (10-40)	20 (10-40)
Cu (µg/L)		85 (70-120)	35 (20-80)
Cr (µg/L)		4.5 (0-10)	1 (0-5)
Cd (µg/L)		1.5 (0-4)	ND
As (µg/L)		3 (0-6)	ND
Zn (µg/L)		160 (120-280)	60 (40-90)
Al (µg/L)		225 (100-400)	100 (50-240)
<i>E. coli</i> (CFU/100mL)		10 (0-60)	ND

<sub>1</sub> Values are means, values in parentheses are standard deviations

<sub>2</sub> Values are medians, values in parentheses are ranges

<sub>3</sub> No detection

Treatment for rainwater is dependent on local guidelines. The City and County of San Francisco, CA allows for toilet flushing with untreated greywater. In Portland, OR, rainwater must be filtered before using for non-potable indoor uses. Texas requires both filtration and disinfection before the water can be used indoors for non-potable demands. Germany showed that the risk of human mouth contact with *E. coli* from toilet flushing was almost non-existent. As a result, it was recommended that disinfection is unnecessary

for rainwater used for non-potable purposes (Kloss 2008). The minimum treatment guidelines and treatment options for stormwater reuse are given in Table 7.

**Table 7. Minimum Water Quality Guidelines and Treatment Options for Stormwater Reuse**

Use	Minimum Water Quality Guidelines	Suggested Treatment Options
Potable indoor uses	<ul style="list-style-type: none"> <li>• Total coliforms – 0</li> <li>• Fecal coliforms – 0</li> <li>• Protozoan cysts – 0</li> <li>• Viruses – 0</li> <li>• Turbidity &lt; 1 NTU</li> </ul>	<ul style="list-style-type: none"> <li>• Pre-filtration – first flush diverter</li> <li>• Cartridge filtration – 3 micron sediment filter followed by 3 micron activated carbon filter</li> <li>• Disinfection – chlorine residual of 0.2 ppm or UV disinfection</li> </ul>
Non-potable indoor uses	<ul style="list-style-type: none"> <li>• Total coliforms &lt; 500 cfu per 100 mL</li> <li>• Fecal coliforms &lt; 100 cfu per 100 mL</li> </ul>	<ul style="list-style-type: none"> <li>• Pre-filtration – first flush diverter</li> <li>• Cartridge filtration – 5 micron sediment filter</li> <li>• Disinfection – chlorination with household bleach or UV disinfection</li> </ul>
Outdoor uses	N/A	<ul style="list-style-type: none"> <li>• Pre-filtration – first flush diverter</li> </ul>

\*cfu – colony forming units

\*NTU – nephelometric turbidity units

From: (Kloss 2008)

### **Rainwater Quantities**

Rainwater is typically collected from the roof of a building (Novotny et al. 2010). The quantity of rainwater collected depends on the size of the roof, the capture efficiency, and the amount of rainfall a region receives. A rule of thumb number for rainwater harvesting is that a rainfall of 1 inch (25.4 mm) on a 1000 square foot (92.9 square meters) house results in 600 gallons (2271 liters) of water being collected (Kloss 2008).

### **Rainwater Use**

Research has established that water collected from roofs is of acceptable quality to be used for toilet flushing, and outdoor uses (Coombes and Barry 2007). Potable use from rainwater is possible but on-site treatment is needed. Rainwater is best used for non-

potable purposes such as irrigation, toilet flushing, and HVAC make-up water (Texas Water Development Board 2005; Kloss 2008).

### **Health Concerns Associated with Rainwater Use**

The health concerns associated with rainwater risk are quite low as long as proper treatment methods are used. The use of filter systems before rainwater enters the cistern helps to eliminate debris and dust from entering the cistern and is suitable for non-potable use. If the harvested rainwater is used for potable water, the water must be treated to eliminate sediment and disease-causing pathogens. Typical treatment consists of filtration and disinfection (Texas Water Development Board 2005).

### **Design Considerations**

The quality of harvested rainwater is dependent on the surface it is collected from. The more debris and contaminants on the collection surface the lower the quality of the collected water. Therefore, the collection surface, usually a roof, should be maintained during dry periods to reduce the amount of contaminants present on the roof surface. The material of the collection surface is also very important. Some metals such as copper leach into the water and increase the concentrations of metals in the rainwater, which can have negative impacts depending on the end-uses of the water. Baked-on enamel, galvalume, and galvanized steel are all acceptable roofing materials for rainwater harvesting. In addition, elastomeric paints have been approved for rainwater harvesting systems (Lancaster 2011).

Using gutter covers, downspout filters, and first-flush diverters improves the quality of harvested rainwater. Gutter covers help to keep large debris such as leaves and twigs out of the gutters. The downspout filters help to remove any debris that passed through the gutter cover. The use of first-flush diverters improves the quality of water by capturing the first portion of runoff from the roof. This part of the runoff contains the highest pollutant load.

A common mistake with rainwater harvesting is to have too small of a cistern. A 50 gallon rainwater barrel will not significantly decrease the potable water demand regardless if the water is used for irrigation or indoor non-potable uses. Overall, small cisterns are more expensive per gallon than larger cisterns (Walker 2010).

Cisterns can be located above or below ground. In climates where freezing occurs, it is wise to locate the cistern below the frost line to ensure that the water does not freeze in the cistern. In warmer climates with no freezing, the cisterns can be located above ground, which reduces the implementation cost because excavation is not needed. With an above ground cistern, the need for a pump may also be eliminated.



Rainwater is typically used for non-potable indoor uses and irrigation; however, with the proper treatment it can be used for potable purposes.

### **Design Process:**

1. Determine end use-goals
  - What is the intended use for the harvested rainwater?
    - Irrigation
    - Toilet flushing
    - Clothes washing
    - Potable use

2. Determine catchment area.

The amount of rainwater that can be harvested is dependent on the catchment area. The catchment area for most buildings is the roof. Only the plan area is of concern, not the actual surface area of the roof.

3. Determine catchment and cistern materials.

If you are installing a rainwater harvesting system on a current house make sure the materials used for the roof, valleys, gutters, and downspouts, will not contaminate the water. Baked on enamel, galvalume, and galvanized steel, and slate are all acceptable roofing materials for rainwater harvesting. In addition, elastomeric paints have been approved for rainwater harvesting systems. PVC is acceptable to use as a pipe material where needed (Texas Water Development Board 2005). Materials acceptable for cistern use include high-density linear polyethylene, polypropylene, among many others (RainHarvest Systems 2011).

Materials such as clay/concrete tile, composite, asphalt, or wood shingles, tar, and gravel are not ideal for rainwater harvesting. Clay and concrete tile are porous, which can lead to reduced runoff collection due to inefficient flow, texture, or evaporation. Clay and concrete tiles might also have toxins that leach from the sealant or paint. If the proper type of paint is used, the surface is safer because it will prevent potential bacterial growth on the porous surface. Composite or asphalt shingles should only be used to collect water for irrigation because of the leaching of toxins. Composite roofs also have a 10% loss of water due to evaporation or inefficient flow. Similarly, wood shingles, tar, and gravel roofs should only be used for irrigation because of possible leaching of compounds (Texas Water Board 2005).

4. Determine water demands for end-use goals.

For irrigation, speak with a local nursery to determine the water requirements for the vegetation to be irrigated. Another way to calculate the irrigation demand is to determine the evapotranspiration rates for the vegetation (Gardels 2011). Ludwig (2009) also gives estimates for irrigation demand.

If the rainwater is going to be used indoors, the values given in Table 1 and Table 2 can be used to calculate the demand.

5. Size the rainwater cistern.

The size of the rainwater cistern is based on the amount of rainfall, rainfall patterns, and the end-uses for the harvested water. North Carolina State University has developed a computer program that can be used to assist in sizing rainwater cisterns. The link is listed in the rainwater resources section. Lancaster (2011) also suggests how to calculate the size of cistern required based on occupancy, daily water use, and the number of days without rain. A link to his website is also listed under the rainwater resources section.

6. Determine the location for the rainwater cistern.

First, decide if the cistern will be located above or below ground. Consider the location of downspouts, overflow connections, and where the water will be used. Locating a cistern close to where the water will be used reduces the pumping costs, and increases the likelihood of being used. An underground cistern should be located at least 50 feet (15.25 m) from septic fields or wastewater application areas. Also, consider any community regulations or Homeowner Association rules. Finally, do not place a cistern over buried pipes, septic tanks, or drain fields. Separation between underground cisterns and structures should also be maintained (Walker 2010).

7. Size the collection system.

The gutters, downspouts, and first flush systems must also be sized based on the climate and size of catchment area. The National Standard Plumbing Code, states that the gutters and downspouts must be sized to handle a 100 year return-period, 60 minute duration storm (Plumbing-Heating-Cooling Contractors Association 2006). This rule also applies to underground pipe used to convey water to an underground cistern. The code lists the corresponding intensity for a 100 year, 60 minute duration storm for cities in the United States. It also gives instructions and tables on how to size the drainage system.

The size of the first-flush diverter is dependent on the size of the roof. Typically 0.01 gal/ft<sup>2</sup> is diverted. Companies such as RainwaterHarvest, LLC sell

3-inch and 4-inch diameter aboveground first-flush diverters, and a 12-inch underground first-flush diverter. The diverters are sold as a kit that allows the homeowner to buy the appropriate length of PVC pipe, which corresponds to the volume of water that must be diverted. Table 8 lists the storage capacity for various pipe diameters.

**Table 8. Storage Capacity of Various Pipe Diameters**

Pipe Diameter		Storage Capacity	
in	mm	gal/ft	l/m
3	76.2	0.384034	4.77
4	101.6	0.661312	8.21
12	304.8	5.814633	72.21

8. Design the distribution system.

The design of the distribution system is dependent on the end-uses selected for rainwater harvesting. For irrigation, the pump must be connected to the irrigation pipe network such as drip irrigation pipes. For indoor use, the pump or pump pressure tank combination should be connected to a manifold. From the manifold the water can be distributed through the building through cross-linked polyethylene (PEX). An example of a rainwater distribution system in a house is shown in Figure 4.

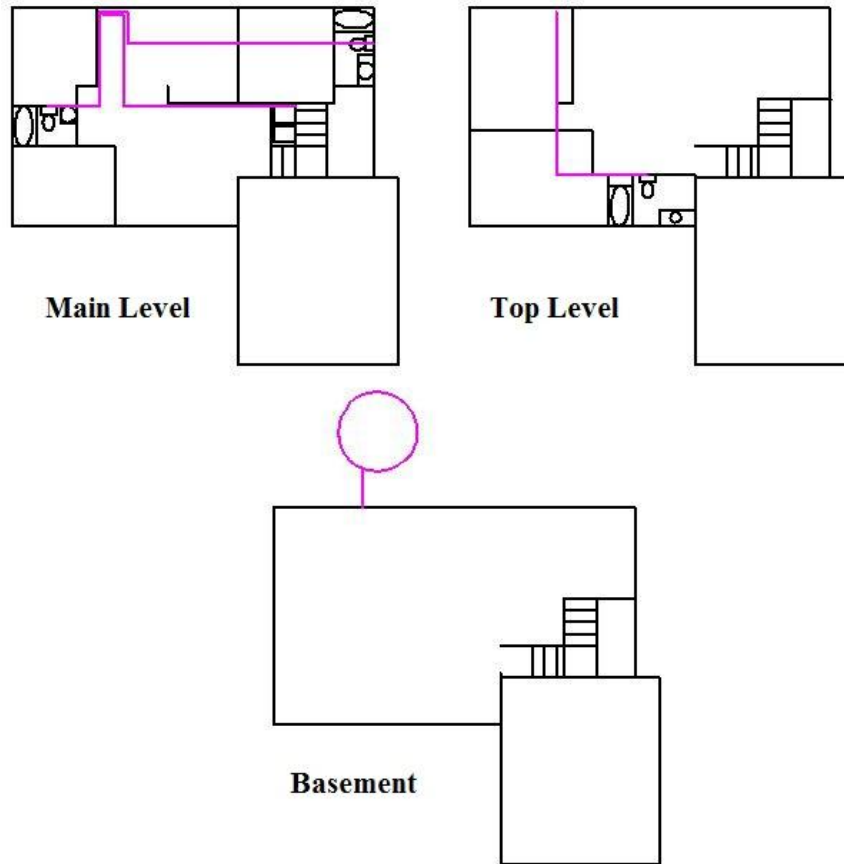

**Figure 4. Example of indoor distribution system for Rainwater.** The purple lines represent the PEX pipe delivering rainwater collected in the underground cistern to the toilets and washing machine in the house.

9. Size the pump for water distribution.

In some situations, the water can be distributed by gravity flow. However, in most cases, a pump is required. The size of the pump is dependent on many variables in the system including the end-uses and the location of the cistern. A pressure tank and pump combination can be used or an on-demand pump can be used to eliminate the pressure tank (Walker 2010). Links given in the rainwater harvesting resources can help with pump sizing as can a local pump supplier.

### Rainwater Harvesting Resources

Basic Rainwater Harvesting information:

American Rainwater Catchment Systems Association. <http://www.arcsa.org>

Commercial Rainwater Harvesting:

Skyharvester. <http://www.skyharvester.com>

Filters, first-flush diverters, pumps, cisterns and information on installing a rainwater harvesting system:

Rainwater Harvest. <http://www.rainharvest.com>

Online forum for rainwater harvesting:

<http://www.harvesth2o.com/>

Implementing rainwater harvesting, list of suppliers for all materials needed for rainwater harvesting, links to additional helpful resources:

Harvesting Rainwater for Drylands and Beyond. Brad Lancaster.

<http://www.harvestingrainwater.com/>

Model to assist in sizing rainwater cistern:

Rainwater Harvesting at NCSU.

<http://www.bae.ncsu.edu/topic/waterharvesting/model.html>

Information on rainwater harvesting components, sizing the system and guidelines:

The Texas Manual on Rainwater Harvesting.

[http://www.twdb.state.tx.us/publications/reports/rainwaterharvestingmanual\\_3rdedition.pdf](http://www.twdb.state.tx.us/publications/reports/rainwaterharvestingmanual_3rdedition.pdf)

## References

- Aladenola, O. O., and Adeboye, O. B. (2010). "Assessing the Potential for Rainwater Harvesting." *Water Resources Management*, 24 2129-2137.
- Al-Jayyousi, O. R. (2003). "Greywater reuse: towards sustainable water management." *Desalination*, 156 181-192.
- Alkhatib, R. Y., Roesner, L. A. and Marjoram, C. (2006). "An Overview of Graywater Collection and Treatment Systems."  
[http://www.engr.colostate.edu/HHSLab/papers/EWRI%202006%20Alkhatib\\_Roesner&Marjoram.pdf](http://www.engr.colostate.edu/HHSLab/papers/EWRI%202006%20Alkhatib_Roesner&Marjoram.pdf) (4/20, 2010).
- Appan, A. (1999). "A dual-mode system for harnessing roofwater for non-potable uses." *Urban Water*, 1 317-321.
- Asano, T. (2007). *Water reuse: Issues, Technology, and Applications*. McGraw-Hill, New York.
- Christova-Boal, D., Eden, R. E., and McFarlane, S. (1996). "An investigation into greywater reuse for urban residential properties." *Desalination*, 106 391-397.
- Coombes, P. J., and Barry, M. E. (2007). "The effect of selection of time steps and average assumptions on the continuous simulation of rainwater harvesting strategies." *Water Science and Technology*, 55(4), 125-133.
- Eriksson, E., Auffarth, K., Eilersen, A., Henze, M., and Ledin, A. (2003). "Household chemicals and personal care products as sources for xenobiotic organic compounds in grey wastewater." *Water SA*, 29(2), 135-146.
- Eriksson, E., Auffarth, K., Henze, M., and Ledin, A. (2002). "Characteristics of grey wastewater." *Urban Water*, 4 85-104.
- Gardels, D. (2011). "Economic Input-Output Life Cycle Assessment of Water Reuse Strategies in Residential Buildings and Communities." .
- Ishida, C. K., Petropoulou, C., Stober, T., Steets, B., Strecker, E., Chatti, D., and Salveson, A. (2009). "Evaluating Greywater for Unrestricted Use." *Water Environment Federation Technical Exhibition and Conference*, 1863-1869.
- Jefferson, B., Palmer, A., Jeffrey, P., Stuetz, R., and Judd, S. (2004). "Grey water characterisation and its impact on the selection and operation of technologies for urban reuse." *Water Science & Technology*, 50(2), 157-164.
- Kloss, C. (2008). "Managing Wet Weather with Green Infrastructure." *Rep. No. EPA-833-F-08-010*, Environmental Protection Agency, .

- Lancaster, B. (2011). "Rainwater Harvesting for Drylands and Beyond." [www.harvestingrainwater.com](http://www.harvestingrainwater.com) (02/22, 2011).
- Lee, J. Y., Yang, J., Han, M., and Choi, J. (2010). "Comparison of the microbiological and chemical characterization of harvested rainwater and reservoir water as alternative water resources." *Sci.Total Environ.*, 408(4), 896-905.
- Li, F., Wichmann, K., and Otterpohl, R. (2009). "Evaluation of appropriate technologies for grey water treatments and reuses." *Water Science & Technology, WST*, 59(2), 249-260.
- Ludwig, A. (2009). *The New Create and Oasis with Greywater: Choosing, Building, and Using Greywater Systems-Includes Branched Drains*. Oasis Designs, .
- Mayer, P. W., DeOreo, W. B., Opitz, E. M., Kiefer, J. C., Davis, W. Y., Dzlegiefewski, B., and Nelson, J. O. (1999). *Residential End Uses of Water*. AWWA Research Foundation, .
- Novotny, V., Ahern, J., and Brown, P. (2010). *Water Centric Sustainable Communities: Planning, Retrofitting, and Building the Next Urban Environment*. John Wiley & Sons, Inc., Hoboken, New Jersey.
- Ottoson, J., and Stenstrom, T. A. (2003). "Faecal contamination of greywater and associated microbial risks." *Water Research*, 37 645-655.
- Plumbing-Heating-Cooling Contractors Association. (2006). *National Standard Plumbing Code*. Plumbing-Heating-Cooling Contractors National Association, Falls Church, VA.
- RainHarvest Systems. (2011). "Tanks." <http://www.rainharvest.com/shop/shopdisplaycategories.asp?id=19&cat=Tanks> (02/22, 2011).
- Sheikh, B. (2010). "White Paper on Graywater." *Water Reuse Association*, .
- Surendran, S., and Wheatley, A. D. (1998). "Grey-Water Reclamation for Non-Potable Re-Use." *Journal of Chartered Institution of Water and Environmental Management*, 12(December), 406-413.
- Texas Water Development Board. (2005). "The Texas Manual on Rainwater Harvesting." *Rep. No. Third Edition*, Texas Water Development Board, Austin, Texas.
- USEPA. (2004). "Guidelines for Water Reuse." *Rep. No. EPA/625/R-04/108*, U. S. Environmental Protection Agency, Washington, DC.

Walker, J. (2010). "Engineered Rainwater Collection and Case Studies for Sustainable Water Management." Webinar.

Zhang, Y., Grant, A., Sharma, A., Chen, D., and Chen, L. (2010). "Alternative Water Resources for Rural Residential Development in Western Australia." *Water Resource Management*, 24 25-36.