

8-2014

# Evaluating the Impact of Bridge Deck Removal Method on the Performance of Precast/Prestressed Concrete I-Girders

Shaddi Assad

University of Nebraska-Lincoln, sassad@unomaha.edu

Follow this and additional works at: <http://digitalcommons.unl.edu/constructiondiss>

 Part of the [Civil Engineering Commons](#), [Construction Engineering and Management Commons](#), and the [Structural Engineering Commons](#)

---

Assad, Shaddi, "Evaluating the Impact of Bridge Deck Removal Method on the Performance of Precast/Prestressed Concrete I-Girders" (2014). *Construction Systems -- Dissertations & Theses*. 17.

<http://digitalcommons.unl.edu/constructiondiss/17>

This Article is brought to you for free and open access by the Construction Systems at DigitalCommons@University of Nebraska - Lincoln. It has been accepted for inclusion in Construction Systems -- Dissertations & Theses by an authorized administrator of DigitalCommons@University of Nebraska - Lincoln.

University of Nebraska - Lincoln

DigitalCommons@University of Nebraska - Lincoln

---

Construction Systems -- Dissertations & Theses

Construction Systems

---

# Evaluating the Impact of Bridge Deck Removal Methods on the Performance of I-Girders

Shaddi Assad

George Morcous Ph.D.

Follow this and additional works at: <http://digitalcommons.unl.edu/constructiondiss>

 Part of the [Civil Engineering Commons](#), [Construction Engineering and Management Commons](#), and the [Structural Engineering Commons](#)

---

This Article is brought to you for free and open access by the Construction Systems at DigitalCommons@University of Nebraska - Lincoln. It has been accepted for inclusion in Construction Systems -- Dissertations & Theses by an authorized administrator of DigitalCommons@University of Nebraska - Lincoln.

EVALUATING THE IMPACT OF BRIDGE DECK REMOVAL METHOD ON  
THE PERFORMANCE OF PRECAST/PRESTRESSED CONCRETE I-GIRDERS

by

Shaddi A. Assad

A THESIS

Presented to the Faculty of

The Graduate College at the University of Nebraska

In Partial Fulfillment of Requirements

For the Degree of Master of Science

Major: Construction

Under the Supervision of Professor George Morcous

Lincoln, Nebraska

August, 2014

EVALUATING THE IMPACT OF BRIDGE DECK REMOVAL METHOD ON  
THE PERFORMANCE OF PRECAST/PRESTRESSED CONCRETE I-GIRDERS

Shaddi A. Assad, M.S.

University of Nebraska, 2014

Adviser: George Morcous

Wide flange precast/prestressed concrete I-girders have been widely used by several State Departments of Transportation (DOTs) in the last two decades. These girders have many advantages over standard AASHTO I-girders. Their wide and thick bottom flange accommodates a large number of prestressing strands and their wide and thin top flange provides a shorter deck span, reduced girder weight, greater stability in construction, and adequate platform for workers. Despite these advantages, the wide and thin top flange might be disadvantageous when it comes to deck removal, as it is more susceptible to damage. Therefore there is a need to investigate the impact of deck removal methods on the performance of the supporting wide flange I-girder.

In this thesis, two deck removal methods are presented: saw cutting and jack hammering. The two methods were implemented on the Camp Creek Bridge over I-80 in Lancaster County, NE before demolition due to its functional obsolescence. Different saw cutting and jack hammering techniques were performed for deck removal between girders and on top of girders. Data obtained from using similar techniques on three other projects were collected and analyzed. Two girders from the Camp Creek Bridge were taken to the lab for testing in flexure after applying different levels of deck removals

around shear connectors and re-decking. Test results indicated adequate performance of the new composite section even when partial deck removal around shear connectors is applied.

Another investigation was conducted to evaluate the effect of top flange width on the performance of bridge I-girders. Top flange was assumed to be longitudinally saw cut and its width is reduced by fifty percent. The effects on geometrical properties, flexural capacity, horizontal shear capacity, and deflection were investigated analytically and experimentally under construction loads and service loads. Investigation results indicate that in some cases top flange width does not have significant impact on the structural performance of I-girders.

**Keywords:** Deck Removal, Top Flange, Saw Cutting, Jack Hammering, Hydro-Demolition, Shear Connectors.

## ACKNOWLEDGEMENTS

Nebraska Department of Roads (NDOR), Concrete Industries Inc., and Iowa State University Bridge Research Center deserve to be thanked for their contribution to this research. Acknowledgement also goes to the following individuals who participated in different tasks of the project: Peter Samir, Afshin Hatami, Micheal Asaad, Nazeer Jabbour, and Kelvin Lein.

## TABLE OF CONTENTS

|                                                       |    |
|-------------------------------------------------------|----|
| Aknowledgements.....                                  | iv |
| List of Figures.....                                  | 5  |
| List of Tables .....                                  | 11 |
| Chapter 1. Introduction .....                         | 12 |
| 1.1 Background.....                                   | 12 |
| 1.2 Problem Statement.....                            | 13 |
| 1.3 Objectives .....                                  | 13 |
| 1.4 Thesis Organization .....                         | 14 |
| Chapter 2. Literature Review.....                     | 15 |
| 2.1 Publications.....                                 | 15 |
| 2.2 Surveys.....                                      | 15 |
| 2.2.1 Nebraska Department of Roads (NDOR) Survey..... | 15 |
| 2.2.2 Iowa State University (ISU) Survey .....        | 20 |
| 2.3 ISU Research .....                                | 21 |
| 2.4 Workshops .....                                   | 27 |
| 2.4.1 Deck Removal Between Girders.....               | 27 |
| 2.4.2 Deck Removal On Top of Girders.....             | 27 |
| 2.4.3 Proposed Methods for Research .....             | 27 |

|                                                                 |    |
|-----------------------------------------------------------------|----|
|                                                                 | 2  |
| 2.4.4 Effective Sequencing of Tasks.....                        | 31 |
| Chapter 3. Field Investigations .....                           | 32 |
| 3.1 Camp Creek Bridge.....                                      | 32 |
| 3.1.1 Evaluation of Removal Methods: Between the Girders .....  | 34 |
| 3.1.1.1 Method 1 and 2: Vertical Cut Panels .....               | 35 |
| 3.1.1.2 Method 3: Sloped Cut Panels.....                        | 38 |
| 3.1.1.3 Deck Peeling.....                                       | 40 |
| 3.1.2 Evaluation of Removal Methods: On Top of the Girders..... | 42 |
| 3.1.2.1 Method 1 (JH1).....                                     | 42 |
| 3.1.2.2 Method 2 (JH2).....                                     | 43 |
| 3.1.2.3 Method 3 (JH3).....                                     | 44 |
| 3.2 Chappell Bridge .....                                       | 46 |
| 3.3 Salt Creek Bridge.....                                      | 49 |
| 3.4 Pacific St. and 106 <sup>th</sup> Street Bridge .....       | 52 |
| Chapter 4. Cost Data.....                                       | 56 |
| Chapter 5. Analytical Investigations.....                       | 59 |
| 5.1 Introduction.....                                           | 59 |
| 5.2 Comparison of Geometric Properties.....                     | 59 |
| 5.3 Example 1: Analysis of Camp Creek Bridge.....               | 62 |
| 5.3.1 Bridge Parameters.....                                    | 62 |



|                                                                            |     |
|----------------------------------------------------------------------------|-----|
|                                                                            | 3   |
| 5.3.2 Effect of Flange Width Reduction on Flexural Capacity and Deflection | 64  |
| .....                                                                      | 64  |
| 5.3.3 Effect of Flange Width Reduction on Horizontal Shear Capacity.....   | 68  |
| 5.4 Example 2: Oxford South Bridge .....                                   | 70  |
| 5.4.1 Bridge Parameters .....                                              | 70  |
| 5.4.2 Effect of Flange Width Reduction on Flexural Capacity and Deflection | 72  |
| .....                                                                      | 72  |
| 5.4.3 Effect of Flange Width Reduction on Horizontal Shear Capacity.....   | 76  |
| 5.5 Conclusion .....                                                       | 78  |
| Chapter 6. Experimental Investigation .....                                | 79  |
| 6.1 Specimen Preparation .....                                             | 81  |
| 6.1.1 Saw Cutting Sequence .....                                           | 81  |
| 6.1.1.1 Full Flange Girder.....                                            | 82  |
| 6.1.1.2 Cut Flange Girder .....                                            | 84  |
| 6.1.2 Jack hammering Sequence.....                                         | 87  |
| 6.2 Specimen Testing.....                                                  | 96  |
| 6.2.1 Re-Decking .....                                                     | 97  |
| 6.2.2 Test Setup.....                                                      | 99  |
| 6.3 Analysis of Results .....                                              | 101 |
| 6.3.1 Concrete Compressive Strength.....                                   | 101 |

|                                    |     |
|------------------------------------|-----|
|                                    | 4   |
| 6.3.2 Full Flange Girder Test..... | 102 |
| 6.3.3 Cut Flange Girder Test.....  | 105 |
| 6.3.4 Comparison .....             | 109 |
| 7. Conclusions.....                | 111 |
| 8. Recommendations.....            | 112 |
| Works Cited .....                  | 114 |

## LIST OF FIGURES

|                                                                                                            |    |
|------------------------------------------------------------------------------------------------------------|----|
| FIGURE 1-1: CROSS SECTIONS OF STANDARD AASHTO GIRDERS (LEFT) AND NU<br>GIRDERS (RIGHT).....                | 12 |
| FIGURE 2-1: ISU SHEAR CONNECTOR TEST SETUP .....                                                           | 22 |
| FIGURE 2-2: ANGLE + BAR, C-CHANNEL, AND SHEAR STUD CONNECTORS .....                                        | 23 |
| FIGURE 2-3: SPECIMEN FORMING ( <i>COURTESY OF ISU BRIDGE CENTER</i> ) .....                                | 24 |
| FIGURE 2-4: ISU PUSH-OFF TEST SETUP ( <i>COURTESY OF ISU BRIDGE CENTER</i> ).....                          | 24 |
| FIGURE 2-5: SHEAR STUD CONNECTOR FAILURE MODE ( <i>COURTESY OF ISU BRIDGE<br/>CENTER</i> ) .....           | 25 |
| FIGURE 2-6: LOAD VS AVERAGE DISPLACEMENT FOR SHEAR STUDS ( <i>COURTESY OF<br/>ISU BRIDGE CENTER</i> )..... | 25 |
| FIGURE 2-7: LOAD VS AVERAGE DISPLACEMENT FOR C-CHANNEL ( <i>COURTESY OF<br/>ISU BRIDGE CENTER</i> ).....   | 26 |
| FIGURE 2-8: LOAD VS AVERAGE DISPLACEMENT FOR ANGLE + BAR ( <i>COURTESY OF<br/>ISU BRIDGE CENTER</i> )..... | 26 |
| FIGURE 2-9: SLOPED SAW CUT ALTERNATIVE .....                                                               | 29 |
| FIGURE 2-10: ALTERNATIVE METHOD IN POURING NEW DECK ONTOP OF OLD<br>DECK.....                              | 29 |
| FIGURE 2-11: VERTICAL SAW CUT AT DEBONDED ZONE ALTERNTAIVE.....                                            | 30 |
| FIGURE 2-12: ALTERINATIVE METHOD VERTICAL SAW CUT OUTSIDE SHEAR<br>CONNECTORS.....                         | 31 |
| FIGURE 3-1: ELEVATION AND CROSS SECTION VIEWS OF THE CAMP CREEK<br>BRIDGE.....                             | 33 |

|                                                                                                                           |    |
|---------------------------------------------------------------------------------------------------------------------------|----|
| FIGURE 3-2: ORGANIZATIONAL CHART OF THE METHODS IMPLEMENTED FOR DECK REMOVAL.....                                         | 33 |
| FIGURE 3-3: IMPLEMENTED METHODS BETWEEN GIRDERS.....                                                                      | 34 |
| FIGURE 3-4: PLAN VIEW OF THE METHODS IMPLEMENTED FOR DECK REMOVAL IN-BETWEEN GIRDERS .....                                | 35 |
| FIGURE 3-5: THE DECK WHILE SAW CUTTING, SHOWING THE PANEL NUMBERS COMPARED TO THE PLAN VIEW OF THE PROPOSED METHODS ..... | 35 |
| FIGURE 3-7: LIFTING ONE SIDE OF THE PANEL TO BREAK IT LOOSE.....                                                          | 36 |
| FIGURE 3-8: BREAKING PANEL FROM DECK USING A HAMMER AND A CHISEL.....                                                     | 37 |
| FIGURE 3-9: JACK HAMMERING THE DECK ATTACHED TO THE PANEL HAUNCH...                                                       | 38 |
| FIGURE 3-11: LIFTING THE SLOPPED CUT PANEL .....                                                                          | 39 |
| FIGURE 3-12: THE CAT 330DL EXCAVATOR PEELING THE OVERHANG DECK .....                                                      | 40 |
| FIGURE 3-13: PART OF THE DECK THAT WAS PEELED OFF .....                                                                   | 41 |
| FIGURE 3-14: JACK HAMMERING THE DECK USING BACKHOE.....                                                                   | 41 |
| FIGURE 3-15: PLAN VIEW OF ALL THE JACK HAMMERING METHODS USED.....                                                        | 42 |
| FIGURE 3-16: 14” WIDE X 5” LONG FULL DEPTH JACK HAMMERED STRIP .....                                                      | 43 |
| FIGURE 3-17: THE 4’10” X 3’2” JACK HAMMERED STRIP .....                                                                   | 44 |
| FIGURE 3-18: THE 4’10” X 3’ 1/2” JACK HAMMERED STRIP.....                                                                 | 44 |
| FIGURE 3-19: I-80 CHAPPELL BRIDGE CROSS SECTIONAL VIEW AND DIMENSIONS                                                     | 46 |
| FIGURE 3-20: FOUR SPAN CHAPPELL BRIDGE PLAN VIEW WITH LOCATION OF SAW CUTS .....                                          | 47 |
| FIGURE 3-21: DECK PANEL LIFTED FROM STAY-IN-PLACE FORMS BETWEEN GIRDERS .....                                             | 48 |
| FIGURE 3-22: JACK HAMMERING ABOVE THE GIRDERS .....                                                                       | 48 |
| FIGURE 3-23: DAMAGED SHEAR CONNECTORS AND TOP FLANGE OF THE GIRDER                                                        | 49 |

|                                                                                          |    |
|------------------------------------------------------------------------------------------|----|
|                                                                                          | 7  |
| FIGURE 3-24: PLAN VIEW WITH DIMENSIONS OF SALT CREEK BRIDGE.....                         | 50 |
| FIGURE 3-25: CROSS SECTIONAL VIEW WITH GIRDER SPAN AND THICKNESS OF<br>DECK.....         | 51 |
| FIGURE 3-26: SLAB CRAB LIFTING DECK SLAB FROM WEST TO EAST.....                          | 51 |
| FIGURE 3-27: CONCRETE PIECES FELL TO THE WATERWAY UNDERNEATH.....                        | 52 |
| FIGURE 3-28: PLAN VIEW AND DIMENSIONS OF PACIFIC ST. BRIDGE.....                         | 53 |
| FIGURE 3-29: GIRDER LAYOUT AND SAW CUT LOCATION OF PACIFIC ST. BRIDGE                    | 54 |
| FIGURE 3-30: WORKERS USING HAND CHIPPERS TO REMOVE CONCRETE AROUND<br>SHEAR STUDS.....   | 55 |
| FIGURE 3-31: VIEW LOOKING WEST AFTER COMPLETED DECK REMOVAL .....                        | 55 |
| FIGURE 4-1: ILLUSTRATION OF COST VS. TYPE OF METHOD USED IN DECK<br>REMOVAL.....         | 57 |
| FIGURE 5-1: NON-COMPOSITE CROSS-SECTION OF A FULL FLANGE AND CUT<br>FLANGE SECTION.....  | 61 |
| FIGURE 5-2: NU1100 GIRDER COMPOSITE CROSS-SECTIONAL DIMENSIONS.....                      | 63 |
| FIGURE 5-3: CAPACITY/DEMAND RATIO FOR NU1100 AT ALL LOADING STAGES ...                   | 66 |
| FIGURE 5-4: NU1100 STIRRUP CONFIGURATION.....                                            | 69 |
| FIGURE 5-5: EFFECT OF CUTTING TOP FLANGE ON HORIZONTAL SHEAR CAPACITY<br>FOR NU1100..... | 70 |
| FIGURE 5-6: NU1350 GIRDER COMPOSITE CROSS-SECTIONAL DIMENSIONS.....                      | 72 |
| FIGURE 5-7: CAPACITY/DEMAND RATIO FOR NU1350 (OXFORD BRIDGE).....                        | 75 |
| FIGURE 5-8: NU1350 STIRRUP DISTRIBUTION TO MIDSPAN OF GIRDER .....                       | 77 |
| FIGURE 5-9: EFFECT OF CUTTING TOP FLANGE ON HORIZONTAL SHEAR CAPACITY<br>FOR NU1350..... | 78 |
| FIGURE 6-1: CAMP CREEK GIRDERS LIFTED USING STRAPS.....                                  | 80 |

|                                                                                                                |    |
|----------------------------------------------------------------------------------------------------------------|----|
|                                                                                                                | 8  |
| FIGURE 6-2: VIEW OF GIRDER END AND LOCATION OF TWO CONCRETE CORES ....                                         | 80 |
| FIGURE 6-3: CORES TAKEN FROM BONDED ZONE (LEFT) AND FROM DEBONDED<br>ZONE (RIGHT).....                         | 81 |
| FIGURE 6-4: BONDED CONCRETE SURFACE (LEFT) AND DEBONDED CONCRETE<br>SURFACE (RIGHT).....                       | 81 |
| FIGURE 6-5: COMPOSITE DIMENSIONS OF GIRDERS TAKEN FROM CAMP CREEK<br>BRIDGE.....                               | 82 |
| FIGURE 6-6: LOCATION OF LONGITUDENAL SAW CUTS ON GIRDER #1 .....                                               | 83 |
| FIGURE 6-7: WORKERS MAKING THREE PASSES FOR EACH SAW CUT LOCATION..                                            | 84 |
| FIGURE 6-8: FINISHED SAW CUTS (BEFORE END DECK SECTIONS WERE REMOVED)<br>.....                                 | 84 |
| FIGURE 6-9: LOCATION OF LONGITUDENAL SAW CUTS ON GIRDER #2 .....                                               | 85 |
| FIGURE 6-10: SEPERATION OF DECK AND FLANGE AFTER FALLING DOWN .....                                            | 86 |
| FIGURE 6-11: FINISHED SAW CUTS FOR CUT FLANGE GIRDER .....                                                     | 86 |
| FIGURE 6-12: JACK HAMMERING PLAN FOR GIRDER #1.....                                                            | 88 |
| FIGURE 6-13: JACK HAMMERING PLAN FOR GIRDER #2.....                                                            | 89 |
| FIGURE 6-14: DIFFICULT REMOVING CONCRETE UNDER LONGITUDENAL BARS ...                                           | 90 |
| FIGURE 6-15: JACK HAMMERING DOWN TO STIRRUPS .....                                                             | 91 |
| FIGURE 6-16: DAMAGED FLANGE FROM VIBRATION OF 90LB JACK HAMMER .....                                           | 91 |
| FIGURE 6-17: DAMAGED STIRRUP LEGS.....                                                                         | 92 |
| FIGURE 6-18: TRANSVERSE SAW CUTTING EVERY 5 IN. ....                                                           | 93 |
| FIGURE 6-19: DEPTH OF SAW CUTS ABOUT 4 IN.; 1 IN. FROM TOP FLANGE.....                                         | 93 |
| FIGURE 6-20: LEAVING SPACE UNDERNEATH STIRRUP LEGS, AND REMOVING<br>TRANSVERSE BARS ON FULL FLANGE GIRDER..... | 94 |
| FIGURE 6-21: 1-2 IN. OF SPACE UNDERNEATH STIRRUP LEGS .....                                                    | 94 |

|                                                                                       |     |
|---------------------------------------------------------------------------------------|-----|
|                                                                                       | 9   |
| FIGURE 6-22: DAMAGED FLANGE ON GIRDER #2.....                                         | 95  |
| FIGURE 6-23: BROKEN STIRRUP LEG .....                                                 | 95  |
| FIGURE 6-24: JOB COMPLETED ON OCT 26 <sup>TH</sup> BY NOON .....                      | 96  |
| FIGURE 6-25: TIES WITH PVC PIPE SPACED 3FT APART TO HOLD FORM SIDES .....             | 97  |
| FIGURE 6-26: TOP VIEW OF REINFORCEMENT .....                                          | 97  |
| FIGURE 6-27: VIEW OF FULLY COMPOSITE DECK FOR FULL FLANGE GIRDER.....                 | 98  |
| FIGURE 6-28: CUT SHEAR CONNECTORS IN PARTIALLY REMOVED SECTION .....                  | 98  |
| FIGURE 6-29: CROSS SECTIONAL VIEW OF TEST SETUP (FULL FLANGE GIRDER<br>EXAMPLE) ..... | 99  |
| FIGURE 6-30: ELEVATION VIEW OF TEST SETUP AND SPAN LENGTHS .....                      | 100 |
| FIGURE 6-31: LVDT'S (LEFT), STRAIN GAUGES (RIGHT).....                                | 100 |
| FIGURE 6-32: TEST SETUP ON FULL FLANGE GIRDER.....                                    | 101 |
| FIGURE 6-33: FAILURE MODE OF FULL FLANGE GIRDER .....                                 | 102 |
| FIGURE 6-34: FULL FLANGE - LOAD VS. DEFLECTION GRAPH .....                            | 103 |
| FIGURE 6-35: FULL FLANGE - LOAD VS. STRAIN GRAPH.....                                 | 103 |
| FIGURE 6-36: HORIZONTAL DISPLACEMENT FOR PARTIALLY REMOVED VS. FULLY<br>REMOVED.....  | 104 |
| FIGURE 6-37: VERTICAL DISPLACEMENT FOR PARTIALLY REMOVED VS. FULLY<br>REMOVED.....    | 105 |
| FIGURE 6-38: CUT FLANGE GIRDER FAILURE MODE.....                                      | 106 |
| FIGURE 6-39: CUT FLANGE - LOAD VS. DEFLECTION GRAPH .....                             | 106 |
| FIGURE 6-40: CUT FLANGE - LOAD VS. STRAIN GRAPH.....                                  | 107 |
| FIGURE 6-41: HORIZONTAL DISPLACEMENT FOR PARTIALLY REMOVED VS. FULLY<br>REMOVED.....  | 108 |

|                                                                                    |     |
|------------------------------------------------------------------------------------|-----|
|                                                                                    | 10  |
| FIGURE 6-42: VERTICAL DISPLACEMENT FOR PARTIALLY REMOVED VS. FULLY<br>REMOVED..... | 108 |
| FIGURE 6-43: LOAD VS. DEFLECTION CURVE OF INVESTIGATED NU1100 GIRDERS<br>.....     | 109 |
| FIGURE 6-44: BAR GRAPH COMPARING ACTUAL TO PREDICTED LOAD.....                     | 110 |
| FIGURE 6-45: BAR GRAPH COMPARING ACTUAL TO PREDICTED DEFLECTION .....              | 110 |



## LIST OF TABLES

|                                                                                             |     |
|---------------------------------------------------------------------------------------------|-----|
| TABLE 2-1: DOT'S RESPONSE TO THE SURVEY (1/2) .....                                         | 18  |
| TABLE 2-2: EQUIPMENT AND TOOLS USED FOR DIFFERENT METHODS.....                              | 20  |
| TABLE 2-3: EVALUATION OF DECK REMOVAL METHODS .....                                         | 21  |
| TABLE 4-1: RSMEANS 2010 COST DATA FOR DECK REMOVAL METHODS .....                            | 56  |
| TABLE 4-2: COST ANALYSIS OF CAMP CREEK METHODS.....                                         | 58  |
| TABLE 5-1: NU GIRDER FULL FLANGE AND CUT FLANGE PROPERTIES .....                            | 60  |
| TABLE 5-2: EFFECT OF CUTTING TOP FLANGE ON NU GIRDER SECTIONS.....                          | 61  |
| TABLE 5-3: PARAMETERS OF THE CAMP CREEK BRIDGE.....                                         | 62  |
| TABLE 5-4: FULL AND CUT FLANGE CROSS-SECTIONAL PROPERTIES .....                             | 63  |
| TABLE 5-5: CALCULATED DEAD AND LIVE LOAD MOMENTS.....                                       | 64  |
| TABLE 5-6: CAPACITY/DEMAND COMPARISON OF FULL FLANGE AND CUT FLANGE<br>GIRDER SECTIONS..... | 65  |
| TABLE 5-7: MIDSPAN CRITICAL STRESSES FOR 52 FT LONG NU1100 GIRDER .....                     | 68  |
| TABLE 5-8: PARAMETERS FOR HORIZONTAL SHEAR ANALYSIS ON NU1100 .....                         | 69  |
| TABLE 5-9: PARAMETERS OF OXFORD SOUTH BRIDGE .....                                          | 71  |
| TABLE 5-10: FULL AND CUT FLANGE CROSS-SECTIONAL DIMENSIONS .....                            | 71  |
| TABLE 5-11: CALCULATED DEAD AND LIVE LOAD MOMENTS.....                                      | 73  |
| TABLE 5-12: CAPACITY VS. DEMAND OF FULL FLANGE AND CUT FLANGE GIRDERS<br>.....              | 74  |
| TABLE 5-13: MIDSPAN CRITICAL STRESSES FOR 140 FT LONG NU1350 GIRDER .....                   | 76  |
| TABLE 5-14: PARAMETERS FOR HORIZONTAL SHEAR ANALYSIS ON NU1350 .....                        | 77  |
| TABLE 6-1: SUMMARY OF MAN-HOUR LOG .....                                                    | 96  |
| TABLE 6-2: CONCRETE COMPRESSIVE STRENGTH RESULTS.....                                       | 101 |

# Chapter 1. INTRODUCTION

## 1.1 BACKGROUND

With the evolution of precast/prestressed concrete bridge I-girders comes greater structural capacity and ability to span lengths of up to 200 ft. Figure 1-1 shows the evolution of cross section of typical concrete bridge I-girders from the standard AASHTO girders to PCI Bulb Tee girders, and recently to wide and thin top flange I-girders (e.g. NU girders). Precast/prestressed concrete I-girders with wide and thin top flanges have unique characteristics compared to the other concrete girders. The wide and thin top flange provides an adequate platform for workers, shorter deck span, and reduced girder weight. While the wide and thick bottom flange accommodates a large number of prestressing to improve the section capacity, the wide and thin top flange improves girder stability during construction and reduces the tendency to side sway when long spans are used.

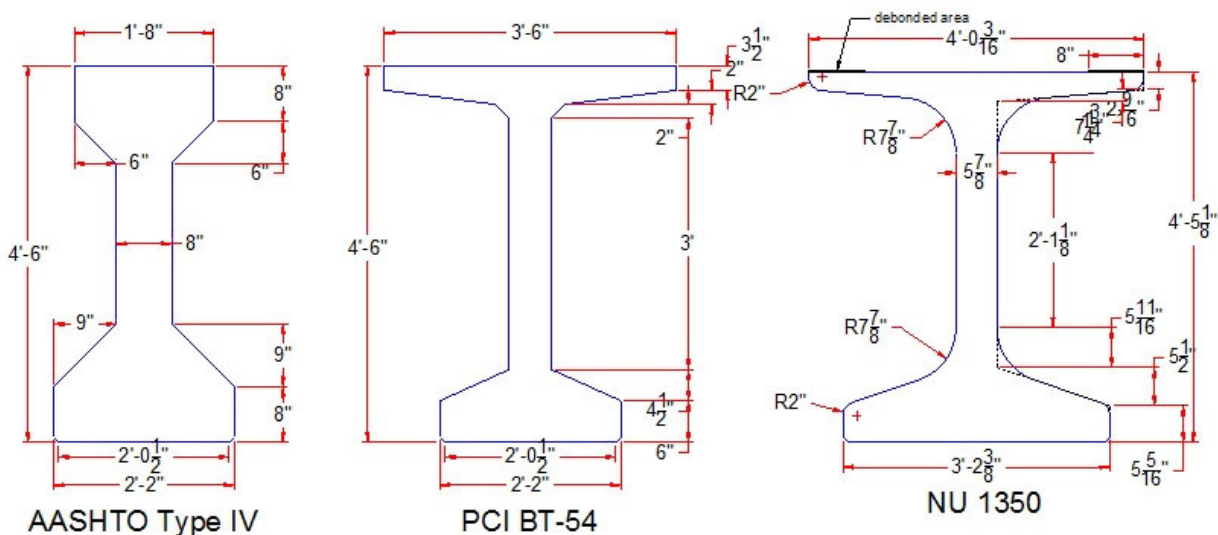

FIGURE 1-1: CROSS SECTIONS OF STANDARD AASHTO GIRDERS (LEFT) AND NU GIRDERS (RIGHT)

NU girders are one of the early examples of I-girder with wide and thin top flange. These girders were developed in the mid-1990s and have been extensively used since then. Although the examples presented in this thesis are using NU girders, all deck removal methods, conclusions, and recommendations apply to other concrete I-girders with wide and thin top flange.

## *1.2 PROBLEM STATEMENT*

Despite the advantages of concrete I-girders with wide and thin top flange, several challenges could be faced during deck removal operations as the top flange is more susceptible to damage than it is in conventional AASHTO and blue tee girders. There are no guidelines, specifications, or experience on deck removal for this generation of I-girders. Therefore, there is a need to investigate different deck removal methods and evaluate their impact on girder condition and performance. Furthermore, there is a lack of research on the efficiency and cost effectiveness of different deck removal methods as well as their impact on the environment.

## *1.3 OBJECTIVES*

The objective of this project is to investigate different deck removal methods and their impact on the structural performance of precast/prestressed concrete I-girders with wide and thin top flange. More specifically, different saw cutting and jackhammering techniques are investigated in terms of the resulting damage to the girder, duration, cost, and impact on the environment.

## *1.4 THESIS ORGANIZATION*

This thesis is organized into six chapters as follows:

Chapter 1: presents background information, problem statement, research objectives, and thesis organization.

Chapter 2: reviews the literature on existing deck removal methods and most common practices currently used by state DOT's.

Chapter 3: presents the findings of the field investigation performed on the Camp Creek Bridge.

Chapter 4: gives a brief introduction to cost analysis of deck removal techniques.

Chapter 5: presents the analytical investigation performed. A proposed deck removal method is analyzed for two bridge examples.

Chapter 6: shows the experimental investigation and validation of the analytical work. The specimen preparation, testing, and test results for the proposed method will be presented.

## Chapter 2. LITERATURE REVIEW

### *2.1 PUBLICATIONS*

NCHRP Report 407 discusses the rapid replacement of bridge decks and states that methods for deck replacement do not affect only the duration and the cost of the project, but also the performance of the supporting structure. Equipment that can be used to remove an old deck can be pneumatic breakers, saws, drills, breakers, splitters, crushers, and blasting charges. The main limitations are the accessibility of the elements to be removed, removal time frame, and environmental and noise restrictions. The improper application of the aforementioned equipment can result in some damage that affect the performance of the structure (Tadros & Baishya, 1998).

One way of deck removal is saw-cutting the deck into small pieces that are manageable to lift and transport. Micro-cracking in the girder's top surface was observed when pneumatic hammers are used. Damage to the top flange can be extensive when rig-mounted breakers, wrecking balls, and blasting charges are used. New techniques, such as chemical splitters and cutters, have been used infrequently, (Tadros & Baishya, 1998).

The province of Alberta in Canada has its specifications for bridge construction. Jack hammers heavier than 14 kg (30 lb) and chipping hammers heavier than 7 kg (15 lb) are not allowed to be used for full depth repair of bridge decks (Alberta Ministry of Transportation, 2010).

### *2.2 SURVEYS*

#### **2.2.1 NEBRASKA DEPARTMENT OF ROADS (NDOR) SURVEY**

A questionnaire was sent to the state DOTs in order to investigate all the possible methods according to the DOT's experience. Most of the DOTs practices were saw cutting between the girders then picking the deck and then jack hammering on top of the girders to remove the remaining part of the deck. Hydro-demolition was suggested by many states, however, with this method, it gets challenging to control the water with the concrete according to EPA requirements. A list of the 10 DOTs that responded to the survey, along with their responses, is shown in Table 2-1.

Of the 10 states that responded to the survey, there were 4 states that practice hydro-demolition. From these 4 states, the response was that hydro-demolition is a noisy and costly removal method with environmental control issues however low risk of damage. The state of Florida mentioned, if labor cost is low jack hammering is used, and if labor cost is high, hydro-demolition is preferred. Also from the response gathered, all states practice conventional saw cutting and jack hammering practices.

The use of pneumatic hammers attached to a mini-excavators or backhoe is a practice used by many states for the first half depth of the bridge deck. The use of pneumatic hammers is more economical but risky, the operators need to be very careful not to damage the girder top flange. The remaining concrete down to the girder top flange is removed using hand chippers and small jack hammers. Contractors typically attempt to bid this method first, such as in the state of Pennsylvania, rather than to hand remove the full depth of the deck. The cost is almost reduced by 33% when pneumatic hammers are used. The cost of removing with a combination of pneumatic hammering and hand chipping is around \$600-\$700/c.y., whereas the cost of using only hand chipping is \$900-\$1000/c.y.

Also from the DOT's response to the survey, the debonded strip at the top flange edge is a good starting place for longitudinal saw cutting and easy lifting of deck panels. Florida DOT's mention to vertical saw cut 2 in. inside top flange and lift deck panels with crane. The Florida DOT also recommends to slope saw cut longitudinally at flange edge so the deck wedges itself after cutting and until it is lifted out.

TABLE 2-1: DOT'S RESPONSE TO THE SURVEY (1/2)

| No. | State        | Contact                                         | Experience         | Methods Used/Recommended for Deck Removal on Bulb-Tee Girders                                                                                                                                                                                                                                                                                                                                                                | Results                                                                                                                                                                                                                     |
|-----|--------------|-------------------------------------------------|--------------------|------------------------------------------------------------------------------------------------------------------------------------------------------------------------------------------------------------------------------------------------------------------------------------------------------------------------------------------------------------------------------------------------------------------------------|-----------------------------------------------------------------------------------------------------------------------------------------------------------------------------------------------------------------------------|
| 1   | Indiana      | James Colonies<br>(317) 467-3964                | Yes                | Hydro-demolition                                                                                                                                                                                                                                                                                                                                                                                                             | Fast, noisy, and costly because of water control                                                                                                                                                                            |
|     |              |                                                 |                    | Small jackhammers                                                                                                                                                                                                                                                                                                                                                                                                            | Slow (1 cft/hr), less noisy, and economical                                                                                                                                                                                 |
| 2   | Minnesota    | Paul Rowekamp<br>(651) 366-4484                 | Yes                | Saw cutting removal of deck sections between beams                                                                                                                                                                                                                                                                                                                                                                           | None                                                                                                                                                                                                                        |
|     |              |                                                 |                    | Hand held cutting and jack hammer removal above the top flange                                                                                                                                                                                                                                                                                                                                                               | Less probable damage and slow but can be easier when good access is provided (false floor on bottom flange)                                                                                                                 |
|     |              |                                                 |                    | Small track mounted pneumatic hammer above the top flange                                                                                                                                                                                                                                                                                                                                                                    | Faster but had more top flange damage than jackhammer                                                                                                                                                                       |
|     |              |                                                 |                    | Steel trowel finish and 6" bond breaker are applied to the newly developed I-beam that has 4 ft wide top flange.                                                                                                                                                                                                                                                                                                             | None                                                                                                                                                                                                                        |
| 3   | New Mexico   | Ray M. Trujillo<br>raymond.trujillo@state.nm.us | Yes, BT-54 girders | Backhoe with a pneumatic hammer                                                                                                                                                                                                                                                                                                                                                                                              | Break some of the top flange.                                                                                                                                                                                               |
|     |              |                                                 |                    | Saw cutting a few inches beyond the edge of the top flanges, then, use chipping hammer to remove the deck above the top flanges                                                                                                                                                                                                                                                                                              | Care needs to be given as the deck removal can break off the thin flanges fairly easy.                                                                                                                                      |
| 4   | Pennsylvania | Tom Macioce<br>(717)787-2881                    | Not Specified      | Saw cut deck with diamond saw at approximately 10 ft intervals transversely. Plunge cuts through parapets at same intervals. Break concrete over beam stirrups using mini-excavator with a small hydraulic hammer for half depth and chipping hammers for the remainder. Remove slab using a gradell or excavator with a slab grab bucket. The same procedure is applied to parapets but they need to be lifted with cables. | More economical but risky. Operations need to be watched closely to ensure that SIP pan clips are not damaging the flanges when pulled out                                                                                  |
|     |              |                                                 |                    | Saw cut the deck and parapet as in the previous method. Machine break and then hand demolition over the entire width of the beam. Leave slabs hanging from some rebars. Torch pan angle welds. Engage slab grab bucket and cut remaining bars. Only chip and free enough length to stay within the lift capacity of the excavator.                                                                                           | Most contractors bid this method and try the first one. Hand chipping over the entire beam top is very expensive (\$900-\$1000 /cy). Combination of machine and hand is probably (\$600-\$700/cy). Hammering is very noisy. |
|     |              |                                                 |                    | First method is used if slabs can be pulled free from SIP clips. Second method is used if slab pans are not pulling free.                                                                                                                                                                                                                                                                                                    | Safety is an issue. Longitudinal fall protection will need to be installed.                                                                                                                                                 |



TABLE 2-1: DOT'S RESPONSE TO THE SURVEY (2/2)

| No. | State      | Contact                               | Experience                | Methods Used/Recommended for Deck Removal on Bulb-Tee Girders                                                                                                                                                                                    | Results                                                                                                                         |
|-----|------------|---------------------------------------|---------------------------|--------------------------------------------------------------------------------------------------------------------------------------------------------------------------------------------------------------------------------------------------|---------------------------------------------------------------------------------------------------------------------------------|
| 5   | Texas      | Kevin Pruski<br>(512) 416-2306        | Yes, Not Bulb Tee Girders | Conventional jack-hammer methods                                                                                                                                                                                                                 | Contractor had to repair beam top flange in many locations.                                                                     |
|     |            |                                       |                           | Hydro-demolition with controlling the depth of removal                                                                                                                                                                                           | None                                                                                                                            |
| 6   | Oregon     | Crain Shike<br>(503) 986-3323         | No                        | No methods are recommended at the meantime                                                                                                                                                                                                       | None                                                                                                                            |
|     |            |                                       |                           | Debonding 8" wide strips at the top flange is a good start                                                                                                                                                                                       |                                                                                                                                 |
| 7   | Virginia   | Julius F. J. Volgyi<br>(804) 786-7537 | No                        | Saw cut between girders and remove deck sections by crane                                                                                                                                                                                        | None                                                                                                                            |
|     |            |                                       |                           | Hydro-blasting of concrete over top flanges to below top layer of deck reinforcement and 1' strips from edge of top flange to top of top flange of girder                                                                                        |                                                                                                                                 |
|     |            |                                       |                           | Small pneumatic hammers (15-20 lbs.) for removal of deck concrete below top reinforcement in the 2 ft wide center strip                                                                                                                          |                                                                                                                                 |
| 8   | Florida    | Steven Plotkin<br>(904) 360-5501      | Yes                       | Concrete over beam flanges is removed using small jack hammers or hydroblasting depending on the cost. Hydroblasting can be controlled in a way that gouging the top flange is not a problem.                                                    | If labor cost is low, jack hammer is used. If labor cost is high, hydroblasting is preferred. They both work well.              |
|     |            |                                       |                           | Deck between beams is removed by either vertical saw cutting 10 ft sections 2 in. inside the top flange and lifting with a crane, or sloped saw cutting over the beam flange tip so the deck wedges itself after cutting until it is lifted out. | The bonding action over the 2 in. strip occasionally produce minor spalls on the beam flange when vertical saw cutting is used. |
| 9   | California | Susan E. Hida<br>(916) 227-8738       | No                        | Recommend full depth saw-cutting outside the limits of the top flange and high pressure water blasting to remove the concrete deck inside the limits of the top flange to prevent damage to the pre-cast bulb-tee girders.                       | None                                                                                                                            |
| 10  | Missouri   | Gregory E. Sanders<br>(573) 526-0245  | No                        | Superstructure removal may be more feasible and economical option.<br>Debonding more of the top flange will certainly help in deck removal.                                                                                                      | None                                                                                                                            |

### 2.2.2 IOWA STATE UNIVERSITY (ISU) SURVEY

A national survey was conducted by the Iowa State University Bridge Center, and a total of 28 states responded on the methods they practice for concrete and steel bridge deck removal. The criteria that methods were evaluated were based on performance, time, cost, noise, and safety. The results of the survey taken are summarized in this section.

Table 2-2 shows deck removal methods currently used by the 28 states that responded to the national survey. A description of tools used in each method is given.

TABLE 2-2: EQUIPMENT AND TOOLS USED FOR DIFFERENT METHODS

| Method          | Equipment                                                                       |
|-----------------|---------------------------------------------------------------------------------|
| Sawing          | Blade saws, Diamond wire saws                                                   |
| Drilling        | Core drills                                                                     |
| Breaking        | Machine-mounted hydraulic breakers, Rig-mounted pneumatic breakers, Whiphammers |
| Splitting       | Mechanical splitters, Chemical Splitters                                        |
| Crushing        | Rig-mounted shears                                                              |
| Hydrodemolition | High-pressure water jets                                                        |
| Ball and Crane  | Wrecking ball attached to a crane                                               |
| Blasting        | Explosives (dynamite, ANFO)                                                     |

For deck removal and re-use of the girders, three methods are considered; saw cutting, breaking, and hydro-demolition. **Error! Reference source not found.** gives a generic comparison of these three methods for the criteria mentioned. Although hydro-demolition has low risks of damage to the girders, it ranks at more costly than other methods and more dangerous for the operator. Saw

cutting and jack hammering are more cost effective, however can also see higher damage to the girders.

TABLE 2-3: EVALUATION OF DECK REMOVAL METHODS

|                                         | <b>Saw Cutting</b> | <b>Breakers (Jackhammering)</b> | <b>Hydrodemolition</b> |
|-----------------------------------------|--------------------|---------------------------------|------------------------|
| <b>Cost</b>                             | Moderate           | Moderate to Low                 | High                   |
| <b>Duration</b>                         | Moderate to Low    | Moderate to Low                 | Moderate               |
| <b>Safety</b>                           | Moderate to High   | Moderate to High                | Moderate               |
| <b>Noise</b>                            | Moderate           | High                            | High                   |
| <b>Risk of Damage to Steel Girders</b>  | Moderate to High   | High                            | None to Low            |
| <b>Risk of Damage to AASHTO Girders</b> | Moderate to Low    | Moderate to Low                 | Low                    |
| <b>Risk of Damage to Bulb-T Girders</b> | Moderate           | Moderate                        | Low                    |

### *2.3 ISU RESEARCH*

ISU Bridge Center has conducted a research on the shear capacity of three different types of shear connectors with varying levels of deck removal. Three different types of shear connectors welded to I-beams were tested for shear capacity and behavior of the connection with the testing variable being different levels of removed concrete; 50%, 75%, and 100%. The three different types of shear connectors are standard shear studs, c-channel connector, and the angle with welded bar connector. The testing consisted of 27 specimens; three specimens for every variation of concrete removal and type of shear connector. The test setup is shown in Figure 2-1.

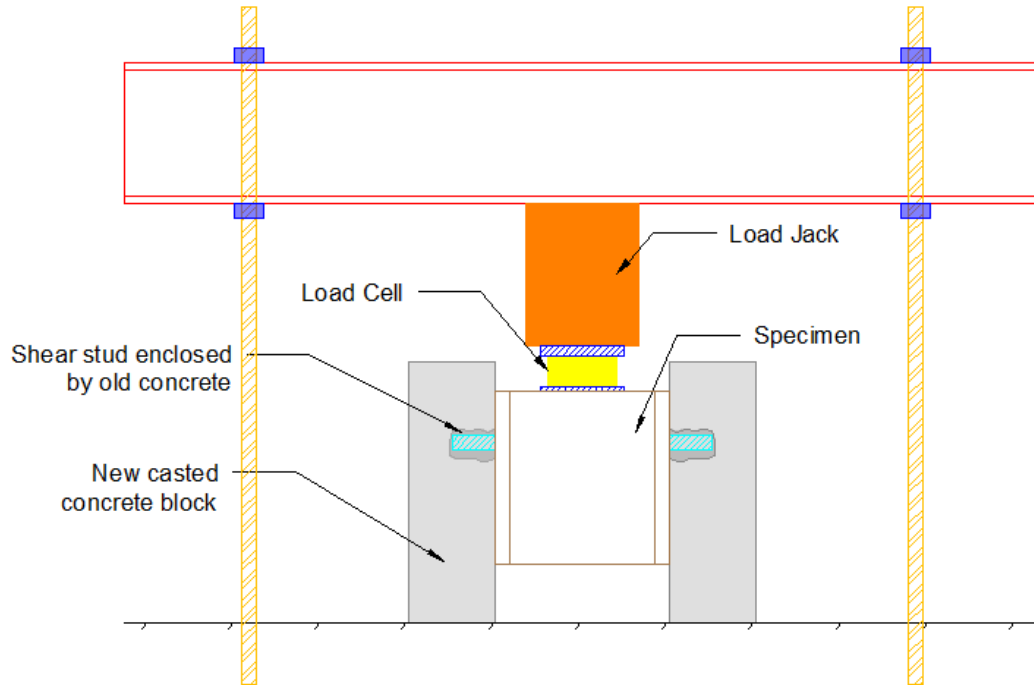

FIGURE 2-1: ISU SHEAR CONNECTOR TEST SETUP

It should be noted that no specific height and width dimensions of the concrete around the connector were used to classify 50%, 75%, or 100%, but instead were classified by weight. Figure 2-2 shows the different types of shear connectors used in testing. The different type of shear connectors used are shear studs, c-channel connectors, and an angle with a welded bar connector.

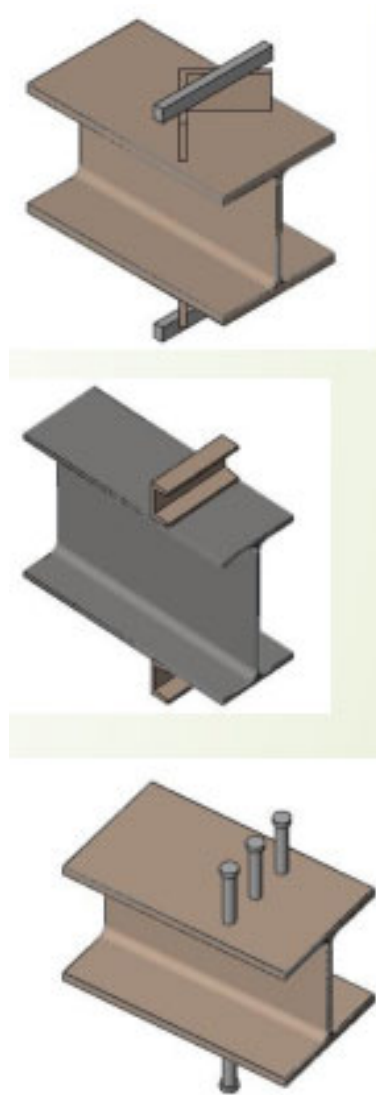

FIGURE 2-2: ANGLE + BAR, C-CHANNEL, AND SHEAR STUD CONNECTORS

Specimen forms were made by casting the “new” deck around the shear connectors with existing concrete on shown in Figure 2-3 and Figure 2-4.



FIGURE 2-3: SPECIMEN FORMING (*COURTESY OF ISU BRIDGE CENTER*)



FIGURE 2-4: ISU PUSH-OFF TEST SETUP (*COURTESY OF ISU BRIDGE CENTER*)

Specimen failure mode is shown in Figure 2-5. All of the shear connector types had the same resultant failure mode, which is shearing off the connector at the deck to girder interface.



FIGURE 2-5: SHEAR STUD CONNECTOR FAILURE MODE (COURTESY OF ISU BRIDGE CENTER)

The results of testing the different connectors with varying concrete deck removal levels of 50%, 75%, and 100% are shown in Figure 2-6 through Figure 2-8. From the graphs, there is no correlation between the level of deck removal and the behavior of the connection. Therefore, it can be concluded that the amount of concrete removal around the shear connectors does not adversely affect the behavior of the connection.

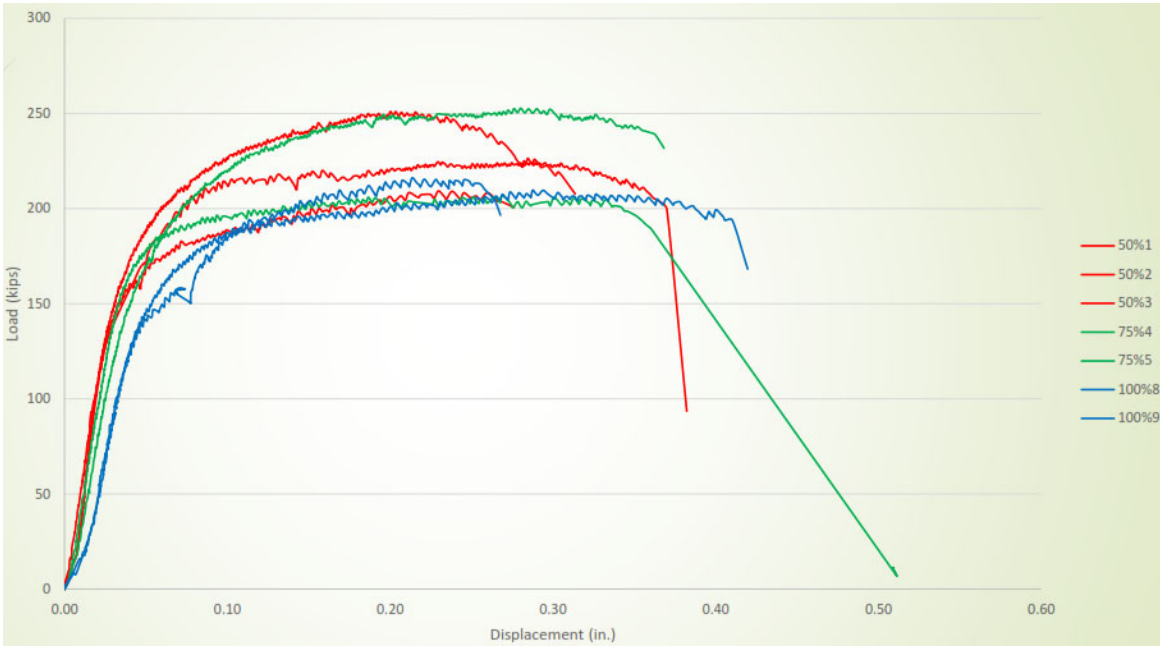

FIGURE 2-6: LOAD VS AVERAGE DISPLACEMENT FOR SHEAR STUDS (COURTESY OF ISU BRIDGE CENTER)

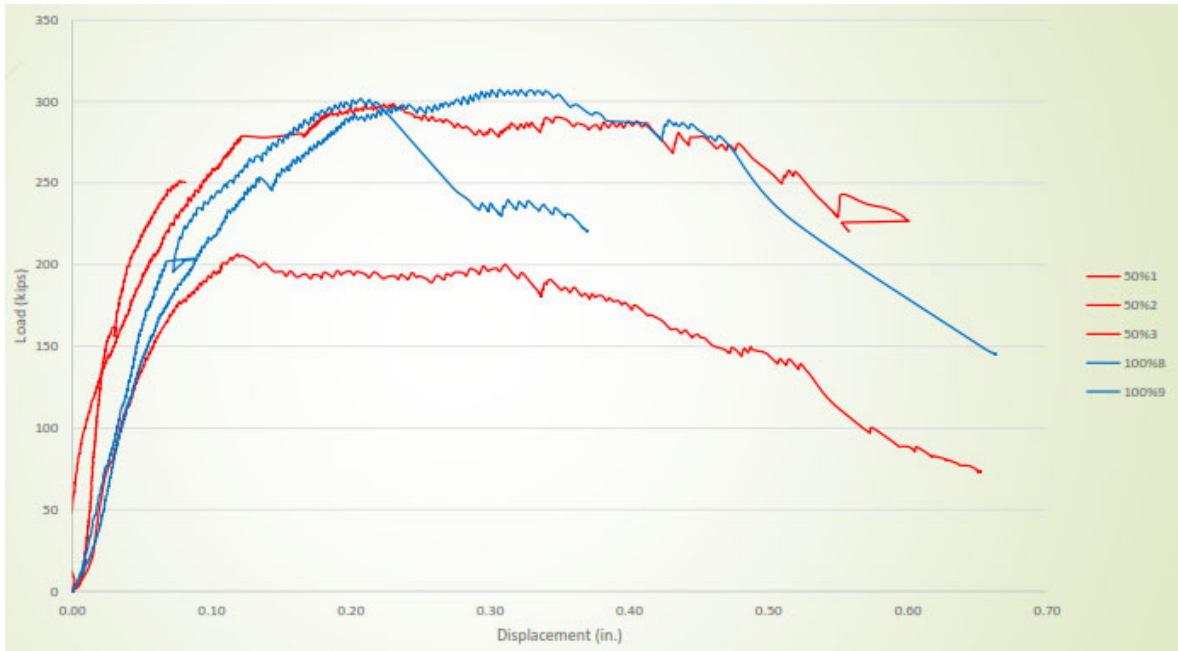

FIGURE 2-7: LOAD VS AVERAGE DISPLACEMENT FOR C-CHANNEL (COURTESY OF ISU BRIDGE CENTER)

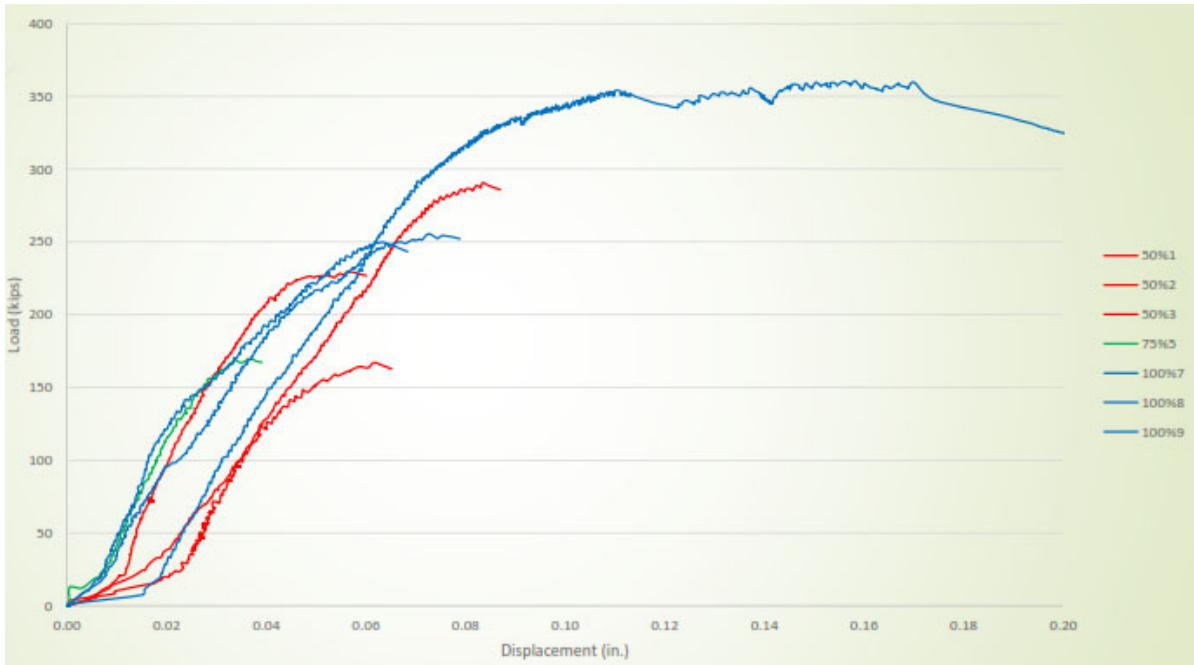

FIGURE 2-8: LOAD VS AVERAGE DISPLACEMENT FOR ANGLE + BAR (COURTESY OF ISU BRIDGE CENTER)



## 2.4 WORKSHOPS

The University of Nebraska-Lincoln (UNL) hosted a workshop on concrete deck removal methods for concrete I-girder on November 16, 2012. Bridge contractors, owners, and researchers discussed effective deck removal methods, procedures, and future tasks in this research project.

### 2.4.1 DECK REMOVAL BETWEEN GIRDERS

For deck removal between girders, the methods are determined by environmental restrictions. The most cost effective would be to break the deck panels down to the ground after saw cutting using a hydraulic hammer mounted on backhoe. However, this method is not permitted with an underlying waterway, highway, or railroad. If there are environmental restrictions, transverse and longitudinal saw cutting followed by lifting deck panels with crane or slab crab will be used. Concrete deck panels are usually 6' x 12' in dimension.

### 2.4.2 DECK REMOVAL ON TOP OF GIRDERS

The use of hydro-demolition, hand operated jack hammering, and small impact jack hammers mounted on excavators are recommended. With different methods available in removing the deck on top of girders, both efficiency and cost need to be investigated.

### 2.4.3 PROPOSED METHODS FOR RESEARCH

Four methods were proposed in removing the deck on top of the girders. These methods include: 1) sloped saw cutting part of the top flange then forming a new deck; 2) milling part of the old deck down to shear connectors and pouring a new deck on top of it; 3) vertical saw cutting down to girder flange and jack hammering the concrete around shear connectors; and 4) saw cutting deck just outside of shear connectors followed by milling old deck down to shear connectors then pouring new deck on it. Conducting cost analysis of these methods need to be investigated, as well as the cost for replacing the entire superstructure (girders and deck) versus removing deck only. In some cases, the cost of precast/prestressed bridge girders per square foot can be close to the cost of deck removal.

#### Method 1- Sloped Saw Cut Top Flange

A saw-cut machine with a blade that could pivot to a certain angle is needed so it can perform slopped cut without the need for the costly and time-consuming operation of using the guided rail with wall saws. In this case, using the slopped saw to cut through the top flange can be good alternative if the structural capacity and stability of the girder when the top flange width is reduced is not a problem. Figure 2-9 shows sketch of this alternative where the shaded area is jack hammered and the new deck is then formed similar to forming decks on steel girders. The new deck can have a haunch to provide adequate cover for the exposed steel in the girder top flange. This alternative does not require the debonded zone, but the ability of cut deck panel to carry the weight of construction equipment needs to be investigated.



### Method 3- Vertical Saw Cut at Debonded Zone

A third alternative is shown in Figure 2-11. Saw cut the deck panels vertically at the debonded zone, use mini-excavator to break the concrete above the girder, and use heavy excavator to break the deck between girders. Avoid using 15-kip and 30-kip jack hammers because using these small jack hammers is very time consuming and costly. In case of having the bridge over waterway or railroad, panels should be cut transversally and lifted using a crane.

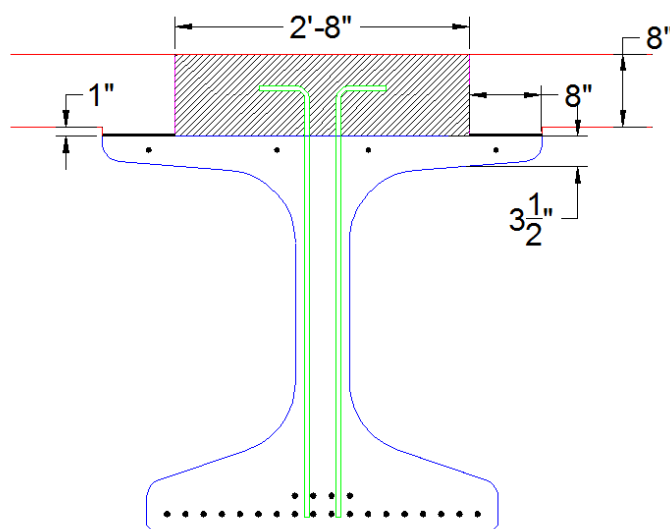

FIGURE 2-11: VERTICAL SAW CUT AT DEBONDED ZONE ALTERNATIVE

### Method 4- Vertical Saw Cut Outside Shear Connectors

A fourth alternative is shown in Figure 2-12. Saw cut deck transversely and longitudinally around shear connectors. Grind the top 2-3 in of the deck over the shear connectors (highway grinder was suggested as a way of milling that 2-3 in.). Remove the remaining concrete around the shear connectors (using small jack hammers or manual hydro-blasting). Finally, lift (pop) the slabs/panels between the girders, which should easily break the bonded area.

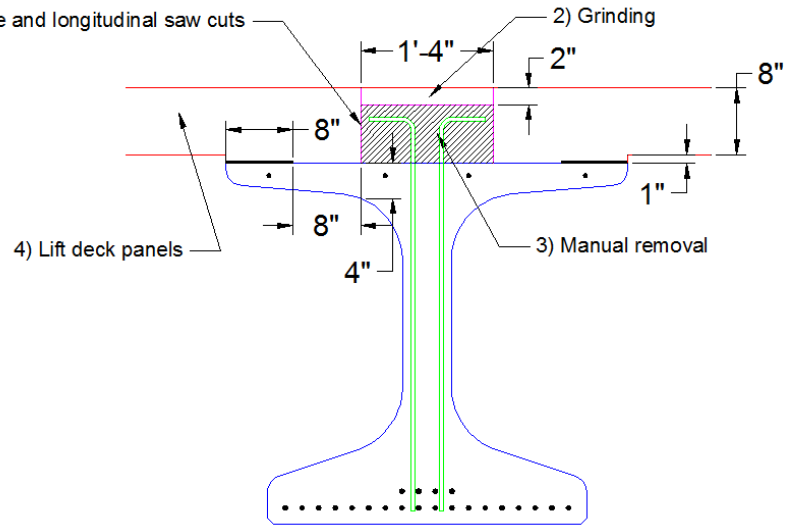

FIGURE 2-12: ALTERNATIVE METHOD VERTICAL SAW CUT OUTSIDE SHEAR CONNECTORS

#### 2.4.4 EFFECTIVE SEQUENCING OF TASKS

To minimize cost and unnecessary movements, each sequence should be planned. The amount of manual work done should be minimized as should the idle time of equipment. Also, saw cutting, jack hammering, and panel lifting should be sequenced so that lifting equipment will be supported on deck panels that are not yet cut and jack hammering is done before lifting adjacent panels. Discussed in the workshop, the recommended sequence of deck removal tasks include:

1. Saw-cut deck transversely for the full width every 10-12 ft.
2. Saw-cut deck longitudinally at the debonded zone over the girder lines.
3. Jack hammer/hydro-blast on top of the two girder lines.
4. Lift panels using crane or hydraulic backhoe to take away deck in between girders.
5. Repeat tasks 1-4 for the following girder lines.
6. For the last two girders, cut, jack hammer, and lift panels section by section.



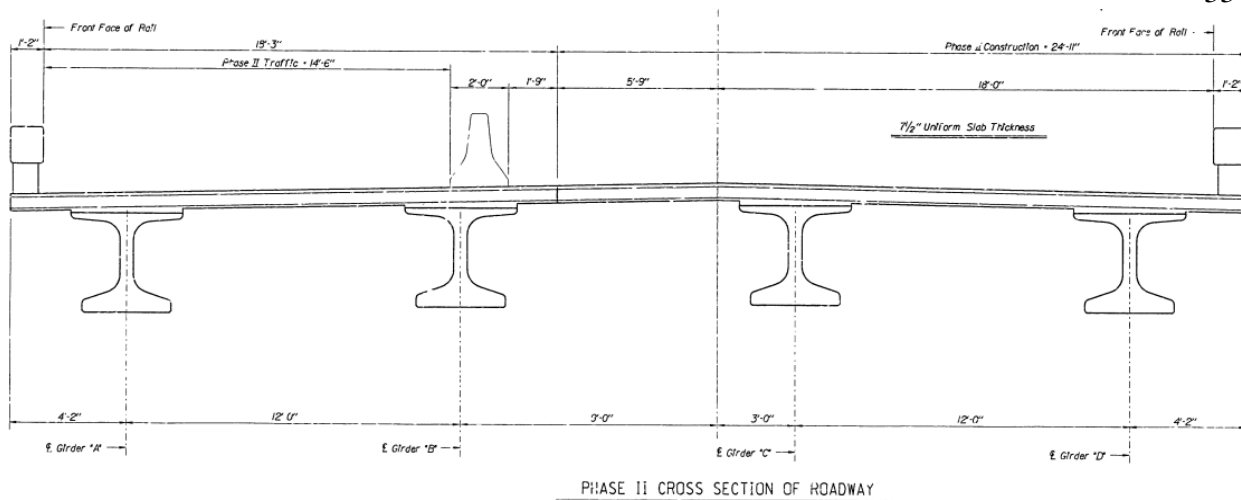

FIGURE 3-1: ELEVATION AND CROSS SECTION VIEWS OF THE CAMP CREEK BRIDGE

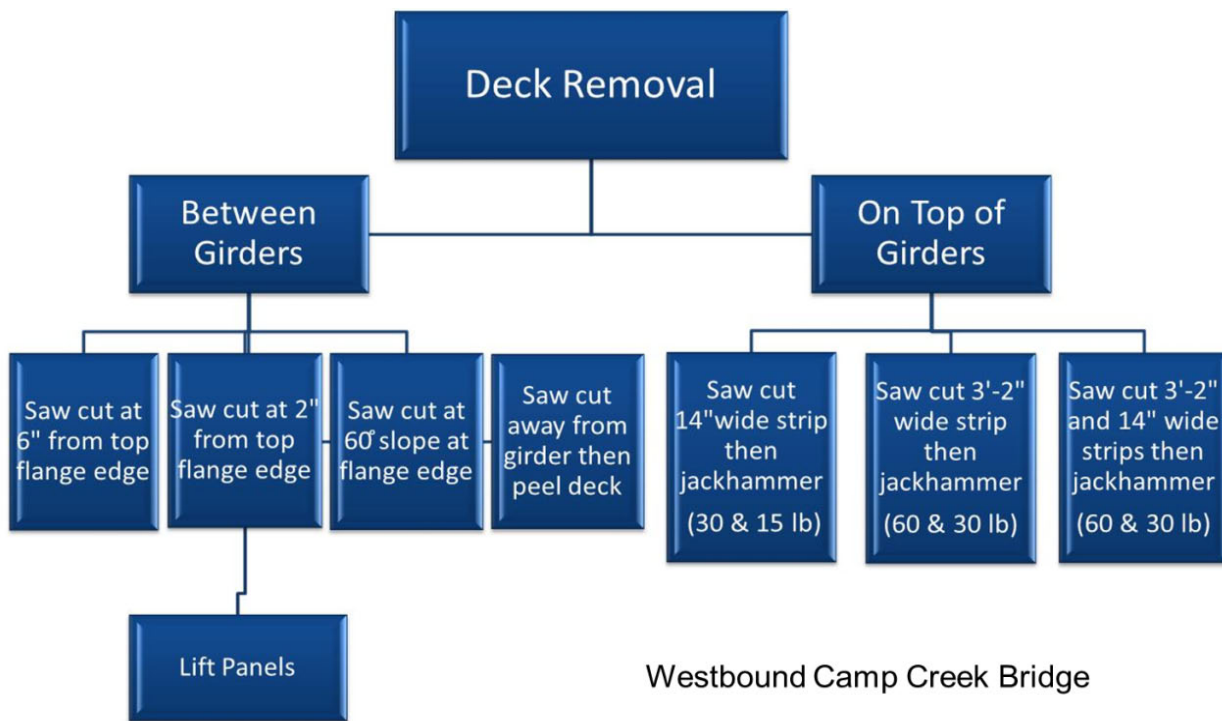

FIGURE 3-2: ORGANIZATIONAL CHART OF THE METHODS IMPLEMENTED FOR DECK REMOVAL

### 3.1.1 EVALUATION OF REMOVAL METHODS: BETWEEN THE GIRDERS

This procedure involved saw cutting the deck transversally into six 8-ft long panels while having three different longitudinal saw cuts as shown in Figure 3-3. Below lists the three different methods used for the longitudinal saw cuts:

1. Saw cutting the deck 6 in. from the edge of the top flange of the girder towards the inside of the girder, which is close to the end of the debonded zone.
2. Saw cutting the deck 2 in. from the edge of the top flange of the girder towards the inside of the girder, which is the standard practice used in conventional bridge girders.
3. Saw cutting the deck at the edge of the top flange with a 60° angle to simplify panel lifting after saw cutting.

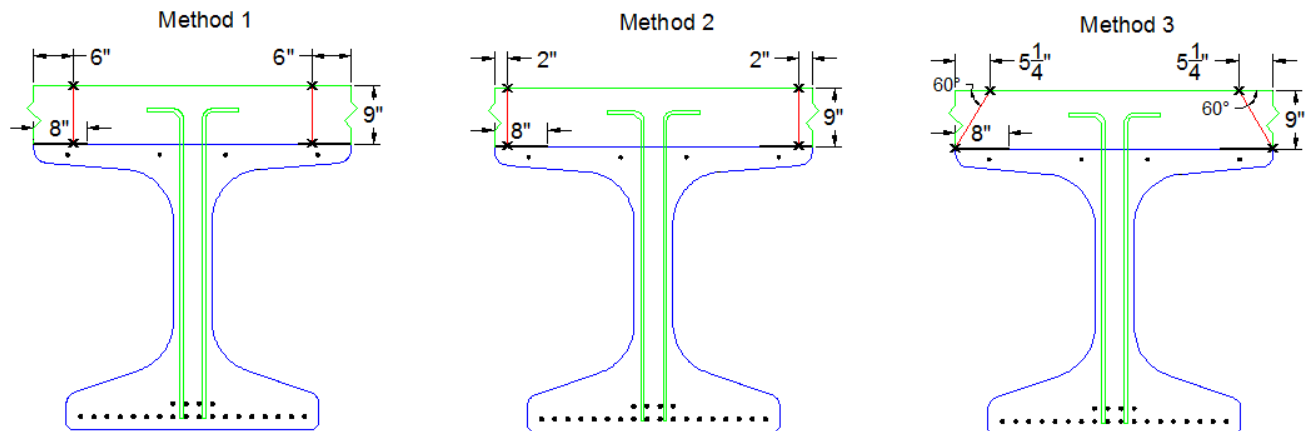

FIGURE 3-3: IMPLEMENTED METHODS BETWEEN GIRDERS

Figure 3-4 and Figure 3-5 give the panel number that corresponds to the method attempted on the panel. Two panels were saw cut and lifted for each method.



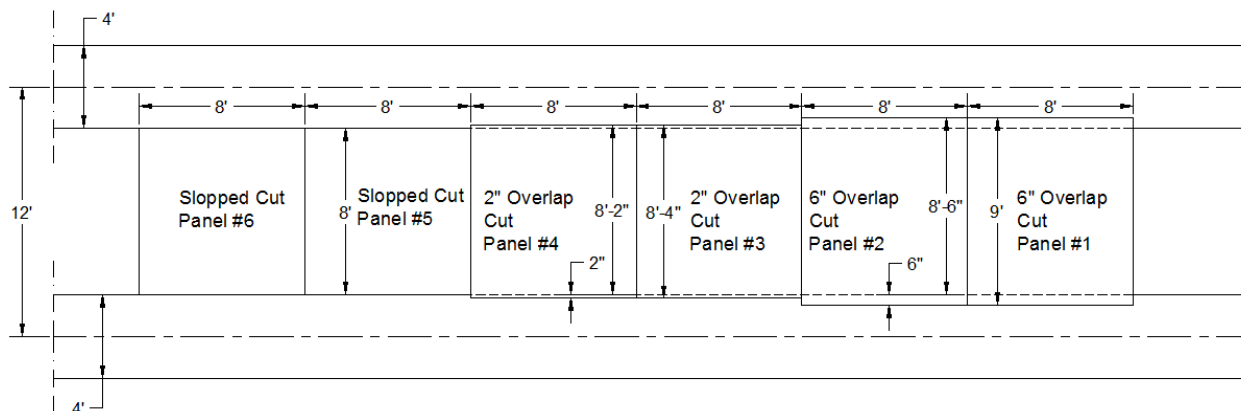

FIGURE 3-4: PLAN VIEW OF THE METHODS IMPLEMENTED FOR DECK REMOVAL IN-BETWEEN GIRDERS

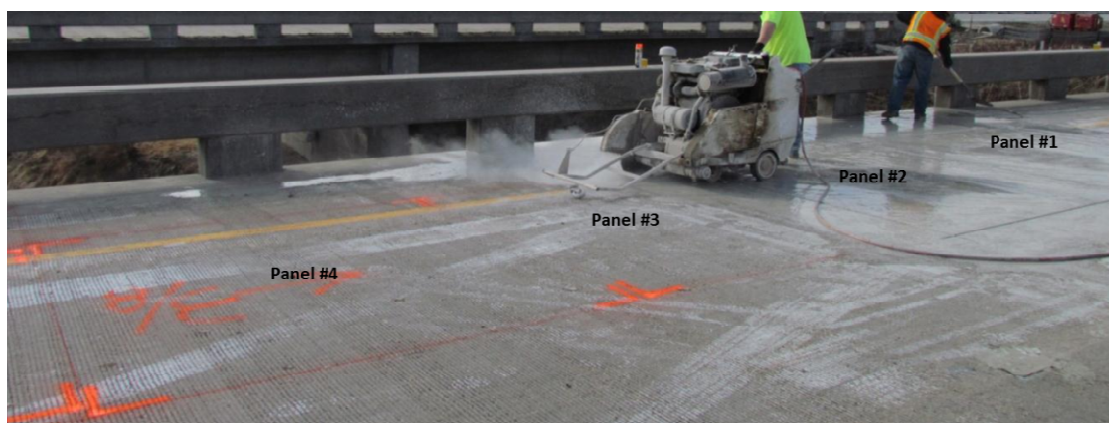

FIGURE 3-5: THE DECK WHILE SAW CUTTING, SHOWING THE PANEL NUMBERS COMPARED TO THE PLAN VIEW OF THE PROPOSED METHODS

### 3.1.1.1 METHOD 1 AND 2: VERTICAL CUT PANELS

Method 1 includes cutting panels #1 and #2 at 6 in. from the edge of the girders, while method 2 includes cutting panels #3 and #4 at 2 in. from the edge of the girder. All panels were transversely saw cut for their full depth (8 in.) at 8 ft spacing. The haunch was 1 in. at the ends of the girders, causing for a deck depth of 9 in. at these locations. All cuts were located at the debonded zone of the girder top flange.

First, 14 in. diameter blades were used for two passes to create 4-4.5 in. deep cut. Second, 18 in. diameter blades were used for one pass to create 6-6.5 in. deep cut. Last, 24 in. diameter blades were used to create 7.5 – 8 in. deep cut. Figure 3-6 shows the three blade sizes used for saw cutting. Each pass took about 1 minute to cut 8 ft long. Three 1/8 in. blades were used in each cut, making for a 3/8 in. wide cut to simplify panel lifting.

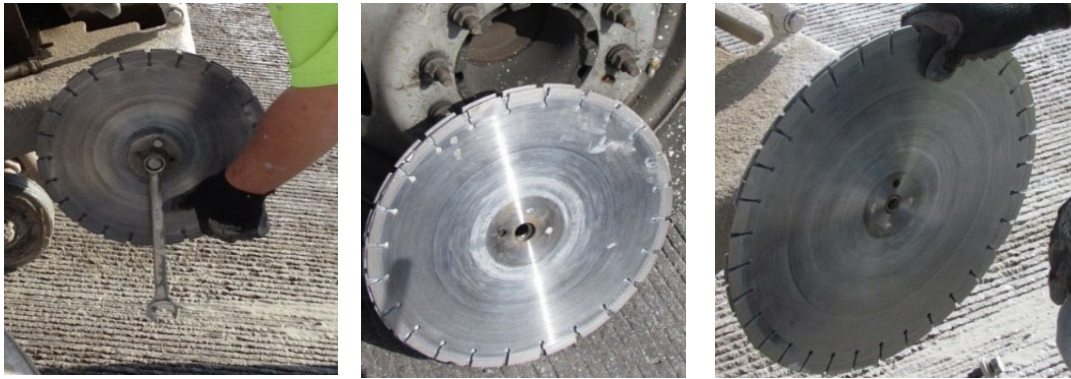

FIGURE 3-6: (FROM LEFT TO RIGHT) 14 IN. DIAMETER, 18 IN. DIAMETER, AND 24 IN. DIAMETER BLADES

Two brackets were anchored at the centerline of the panel at 1 ft away from panel edges. Panels were lifted from one bracket first to break the bond between the panel and the deck, and then the two brackets were used to lift the panel completely (Figure 3-7). The two panels with 2 in. overlap and the first panel with 6" overlap were easily lifted.



FIGURE 3-7: LIFTING ONE SIDE OF THE PANEL TO BREAK IT LOOSE

The second 6 in. overlap panel caused difficulties when the crew was performing the first lift to break the bond between the panel and the remaining part of the deck. The haunch being deeper at that part of the bridge was the reason for the difficulty. The lifted edge was hammered extensively on both sides; however, it could not separate the panel from the deck. A hammer and a chisel were used to break the haunch from the rest of the deck (Figure 3-8). Since the chisel could not go deep enough in the concrete due to the thicker haunch, a 60 lb jack hammer was used to break the deck attached to the haunch (Figure 3-9). As the crane was lifting the edge of the panel and the workers at the same time jack hammering on the panel, the bolts holding the bracket to the concrete slipped out of the panel and the location of the bracket had to be changed. The panel required a lot of wiggling until it was completely lifted. Despite the rough actions the deck has seen, the flange did not show any signs of cracks or damage.



FIGURE 3-8: BREAKING PANEL FROM DECK USING A HAMMER AND A CHISEL



FIGURE 3-9: JACK HAMMERING THE DECK ATTACHED TO THE PANEL HAUNCH

### 3.1.1.2 METHOD 3: SLOPPED CUT PANELS

Panels #5 and #6 were longitudinally saw cut at a 60° slope at the edge of the top flange. For slopped cuts, a single 24 in. diameter blade was used to create 6 in. deep cut in two passes, then a single 30 in. diameter blade was used to complete the full cut in one pass. This procedure took about 20 minutes for 8 ft long cut (Figure 3-10). Another option was attempted to save the time of changing the blades, which was to use a 30 in. diameter blade to make the full depth cut in three passes. Even though the cutting process is easier, the process of installing the frame for the blade and anchoring it to the deck was time consuming; especially with the frame extending a maximum of 10 ft only, so for any extra length, the frame would need to be removed and re-anchored in the new location.

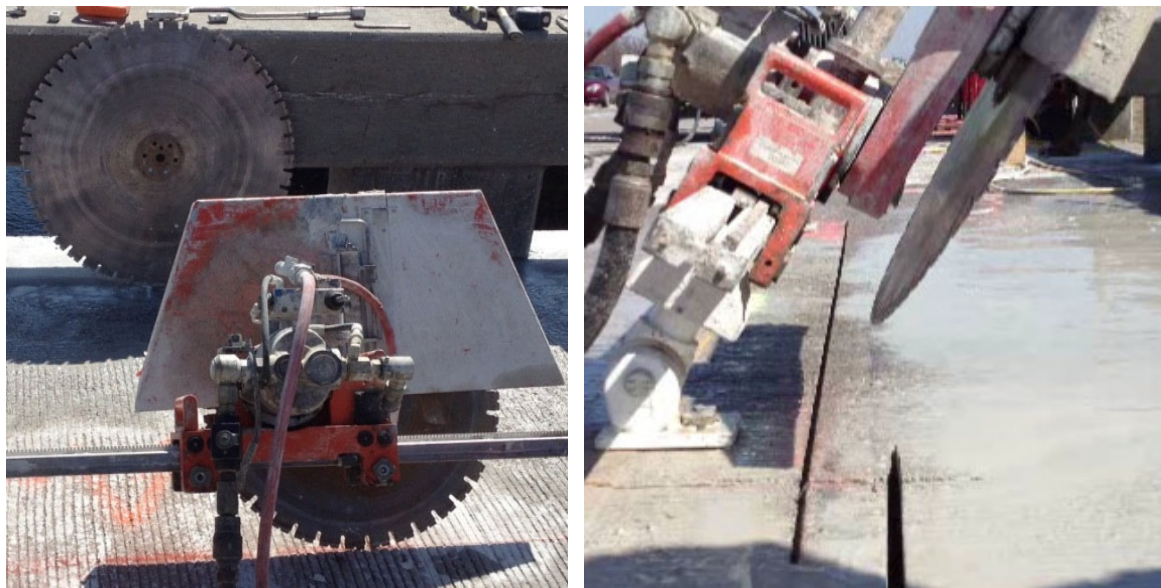

FIGURE 3-10: THE TWO 24 IN. AND 30 IN. DIAMETER BLADES USED IN THE SLOPED CUTS  
(LEFT) AND A SIDE VIEW OF THE SLOPPED BLADE MOUNTING (RIGHT)

The two slopped saw cut panels were lifted first, showing no problems at all (Figure 3-11). Lifting those two panels was determined to be the easiest and fastest way due to the sloped cuts, however the saw cutting required more time. The panels were lifted without causing any damage to the girder.



FIGURE 3-11: LIFTING THE SLOPPED CUT PANEL

### 3.1.1.3 DECK PEELING

The overhang deck in Figure 3-12 was peeled from the supporting girder making use of the 8-in wide debonded strip at the edges of the top flange. A CAT 330DL excavator with a 40 kip capacity was used to lift the edge of the overhang deck. Despite the powerful shaking of the deck, the girder and the deck stayed connected. It was then suggested to push down on the edge of the deck so as to cause tension at the top of the deck and crack it. The deck cracked when it was pushed down, however the crack did not go deeper than the location of the top reinforcement mat. Unlike the rest of the overhang, the west edge of the overhang was saw cut longitudinally; as a result, the deck was broken off the flange at the saw cut line when it was pulled up. The side of the deck was broken; however, the steel reinforcement did not break (Figure 3-13).

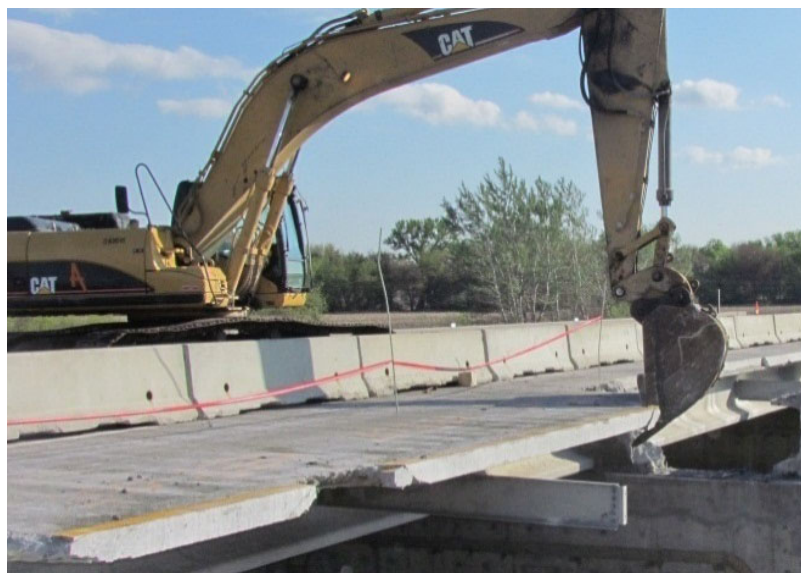

FIGURE 3-12: THE CAT 330DL EXCAVATOR PEELING THE OVERHANG DECK



FIGURE 3-13: PART OF THE DECK THAT WAS PEELED OFF

The deck was then jack hammered transversely to form 6 ft long panels to make it easier to get the deck peeled (Figure 3-14). However, the edge of the flange broke when the deck was jack hammered on top of. When the panel was then lifted by the excavator, the edge of the flange broke more and the process was stopped. Deck peeling proved to be a vigorous, inefficient, and damaging method.



FIGURE 3-14: JACK HAMMERING THE DECK USING BACKHOE

### 3.1.2 EVALUATION OF REMOVAL METHODS: ON TOP OF THE GIRDERS

Referring back to the chart in Figure 3-2, three methods were used to evaluate the most efficient way for jack hammering the deck on top of the girders. The plan view of the methods implemented is shown in Figure 3-15. Three different combinations of longitudinal saw cutting and jack hammering were attempted and labeled JH1, JH2, and JH3. The rate of removal was recorded and presented for each method.

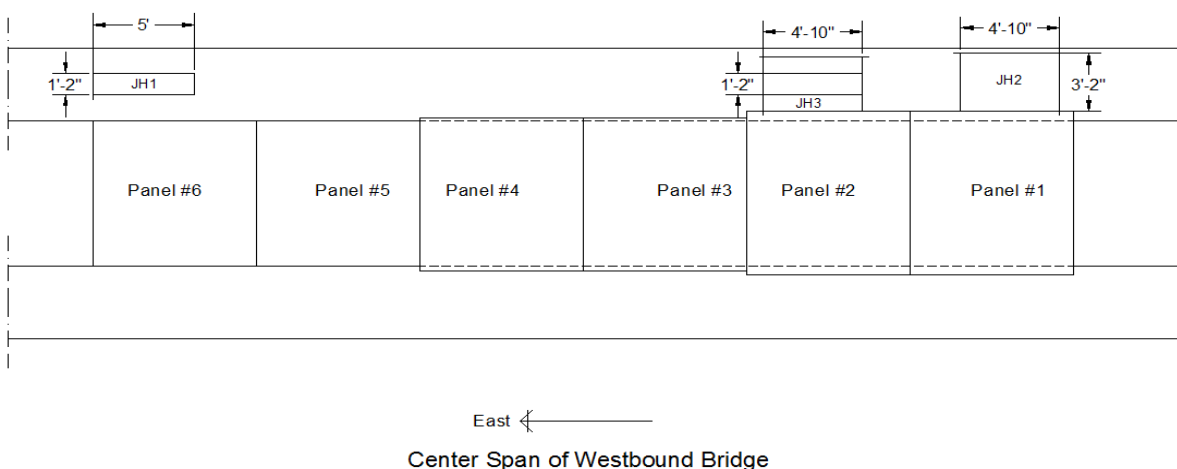

FIGURE 3-15: PLAN VIEW OF ALL THE JACK HAMMERING METHODS USED

#### 3.1.2.1 METHOD 1 (JH1)

The first method was to saw cut the deck around the shear reinforcement forming a 14 in. wide by a 5 ft long rectangle for the full depth of the deck (Figure 3-16). To jack hammer this strip, first, a 30 lb jack hammer was used down to the top reinforcing mat, then, a 15 lb jack hammer was used down to the top of the girder. This process took two hours for a two-man crew to finish it. The rate of deck removal for this method is 0.343 mhr/ft<sup>2</sup>.





FIGURE 3-16: 14" WIDE X 5" LONG FULL DEPTH JACK HAMMERED STRIP

### 3.1.2.2 METHOD 2 (JH2)

In the second method, a 4 ft - 10 in. long by 3 ft - 2 in. wide rectangle was saw cut then jack hammered (Figure 3-17). Jack hammering was performed using 60 lb and 30 lb jack hammers, which is heavier than the specified 30 lb and 15 lb jack hammers for deck removal on top of the girders. The 60 lb jack hammer was used down to the bottom reinforcing steel mat, then the 30 lb one was used down to the top flange of the girder. It took 4 hours for the two man crew to finish the jack hammering process. The girder was slightly damaged when the 30 lb jack hammer slipped off and hit the top of the girder. The rate of deck removal for this method is 0.2613 mhr/ft<sup>2</sup>.



FIGURE 3-17: THE 4'10" X 3'2" JACK HAMMERED STRIP

### 3.1.2.3 METHOD 3 (JH3)

The third method was to cut 4 ft - 10 in. long and 3 ft - ½ in. wide rectangle and remove concrete using 30 lb and 60 lb jack hammers. This method had additional saw cuts. Saw cuts were made directly outside the shear connectors and away from the shear connectors (Figure 3-18). This method was significantly more efficient as the broken deck came out in bigger chunks, hence, took less time and effort. The two man crew needed 1 hour and 38 minutes to finish. The girder had only one location where the jack hammer hit the top surface and caused a 5-½ in. x 2-½ in. piece that was about ½ in. deep to be chipped off the girder. The rate of deck removal for this method is 0.111 mhr/ft<sup>2</sup>.



FIGURE 3-18: THE 4'10" X 3'1/2" JACK HAMMERED STRIP

Based on the observations made in this investigation, the following lessons were learned:

- For wide and thin top flange I-girders, longitudinal saw cuts can be made at 6 in. from top flange edge and achieve the same efficiency in lifting deck panels as with the panels with 2 in. overhang. With the saw cuts further inside the debonded zone, but not passed the debonded zone, a larger portion of deck will be lifted away, leaving less concrete on top of girders to jack hammer. If accessible, multiple blades side-by-side should be used in creating a wider vertical saw cut, for ease of lifting deck panels.
- With current equipment and tools used for slopped saw cutting, the process in having to re-assemble the frame proved to be very inefficient. Although lifting deck panels was very easy, this method should not be considered. Deck peeling also should not be considered because of the high risk in damaging girder top flanges.
- For deck removal on top of girders, the more longitudinal saw cuts made proved to be much more efficient with concrete breaking in larger chunks. With more longitudinal and transverse saw cutting, the time to jack hammer is cut down.

### 3.2 CHAPPELL BRIDGE

The purpose of this investigation is to evaluate the ease of performing deck removal methods in a bridge with stay-in-place forms that need to be re-used for the new deck. Most of bridge decks in Nebraska are currently formed using stay-in-place forms. Observations are made on the ease of deck removal between girders, and damage to stay-in-place forms.

Constructed in 1969, the Chappell Bridge interchange re-decking operations started after 44 years of being in service. The four-span bridge consists of precast/prestressed concrete AASHTO girders with a cast-in-place deck. Saw cutting and jack hammering methods were used to remove the deck. First, longitudinal saw cuts were made 2 in. from the top flanges of the girders on each side. The longitudinal cuts were to the full depth of 7-½ in. Next, transverse saw cuts were made at 7 ft. increments. The saw cut locations can be seen as the red lines in Figure 3-19 and Figure 3-20. Center to center span from girder lines is 5 ft. 6 in. Chappell Bridge spans 48', 88'-6", 88'-6", and 48' from abutment 1 to pier 1, pier 1 to pier 2, pier 2 to pier 3, and pier 3 to abutment 2, respectively.

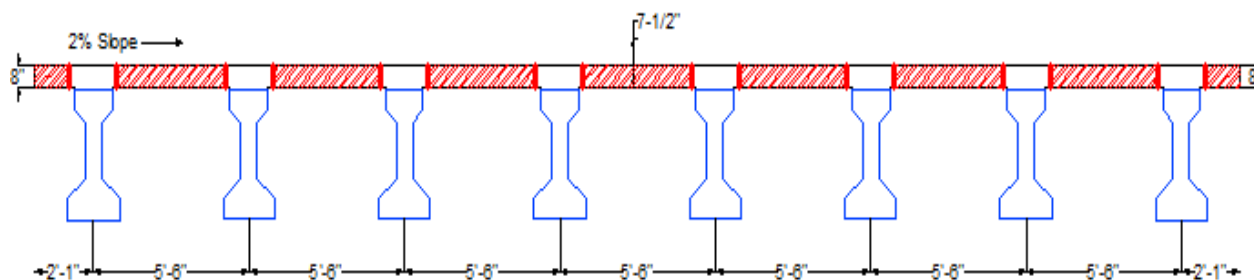

FIGURE 3-19: I-80 CHAPPELL BRIDGE CROSS SECTIONAL VIEW AND DIMENSIONS

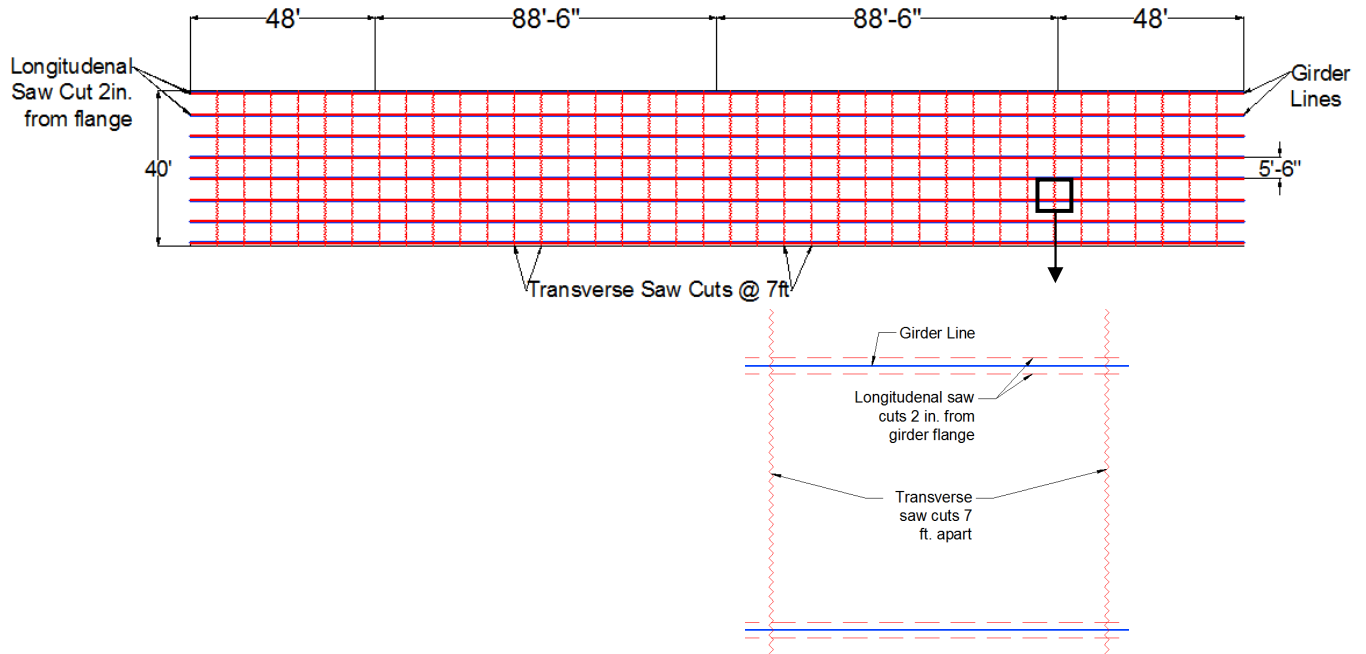

FIGURE 3-20: FOUR SPAN CHAPPELL BRIDGE PLAN VIEW WITH LOCATION OF SAW CUTS

Transverse saw cuts through the epoxy coated rebar were made starting above the middle bridge pier, the deck panels between the girders were lifted off the stay-in-place forms. The deck panels easily lifted away from the stay-in-place forms (Figure 3-21). For the deck on top of the girder, a large jack hammer mounted on an excavator was used to get the majority of concrete broken up and then finished with smaller jack hammers to minimize damaging the girders and shear connectors (Figure 3-22).

Damage occurred with the use of the large jack hammer mounted to the excavator. Figure 3-23 shows the minor damage that occurred to the top flange of the girders, as well as a half dozen shear connectors. The broken straps between the stay-in-place forms will be replaced before casting the new deck. This operation totaled 1300

man hours with 12 crewmen working 9 hour days to remove a 275 ft x 18.58 ft x 7.5 in. deep deck. The rate of deck removal with a 12 crewmen on this project is 0.254 mhr/ft<sup>2</sup>.



FIGURE 3-21: DECK PANEL LIFTED FROM STAY-IN-PLACE FORMS BETWEEN GIRDERS



FIGURE 3-22: JACK HAMMERING ABOVE THE GIRDERS



FIGURE 3-23: DAMAGED SHEAR CONNECTORS AND TOP FLANGE OF THE GIRDER

From this investigation, it was learned that the same deck removal methods presented in the first field investigation can be applied to on a bridge with stay-in-place forms. The deck panels between girders were lifted with ease and minor damage was seen on the stay-in-place forms. Only the straps for the stay-in-place forms needed to be replaced.

### *3.3 SALT CREEK BRIDGE*

The purpose of this investigation is to evaluate deck removal techniques used when environmental restrictions exist. The I-80 Salt Creek Bridge over the Salt Creek waterway in Lincoln, NE was demolished in mid-march of 2013. Due to the environmental restrictions, the bridge deck needed to be removed in slabs by saw-cutting and lifting panels. The bridge has three spans from abutment No.1 to pier No.1, pier No.1 to pier No.2, and pier No.2 to abutment No.2; 105 ft, 140 ft, and 105 ft, respectively. The

bridge has five girder lines with a deck width of 30 ft. The bridge consists of steel I-beam girders with a non-composite cast-in-place concrete deck.

The non-composite action between deck and girders made removing the deck much easier. First, a jack hammer mounted to an excavator was used to remove the overhang of the deck from the rail. Jack hammering was the major contribution to concrete chunks that fell down to the waterway underneath. Saw cutting longitudinally at the center of the deck above the center line girder was done for the whole length of the bridge. Next, transverse saw cuts were made every 5 ft. The non-composite action simplified the removal process, and deck panels easily lifted in 5 ft by 15 ft segments.

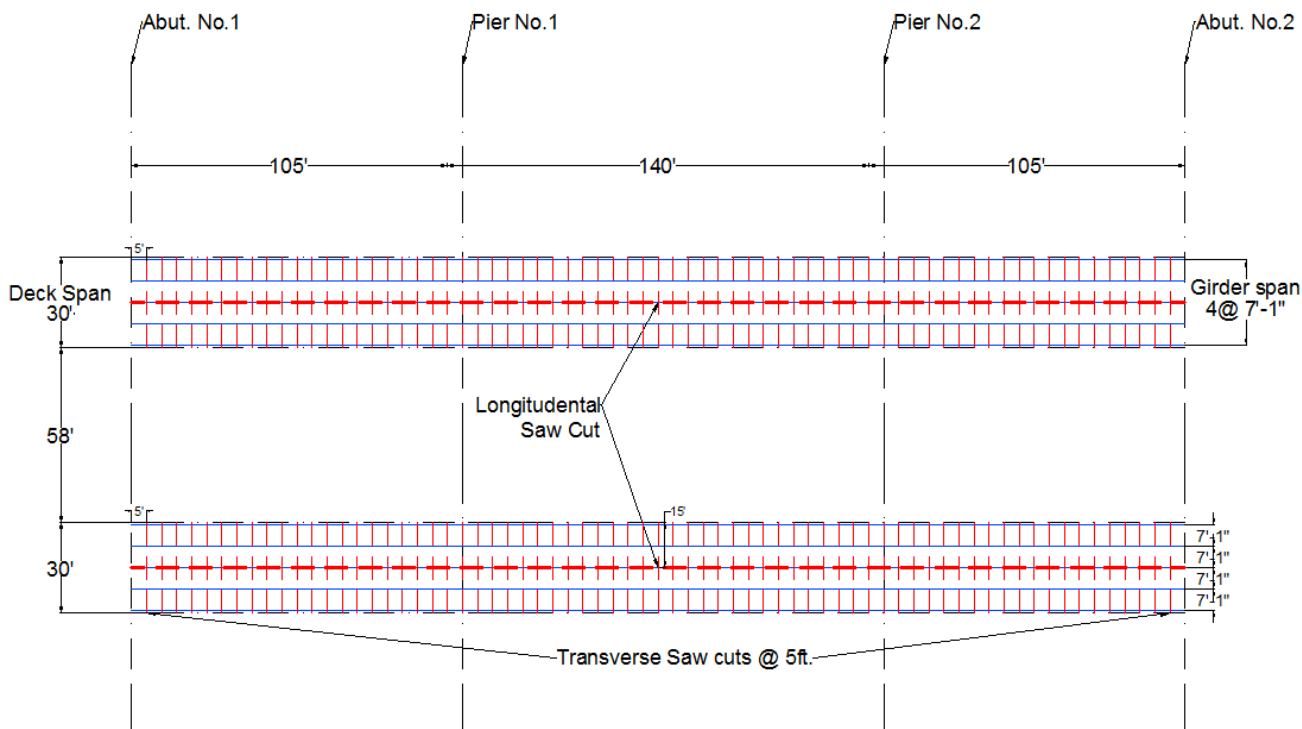

FIGURE 3-24: PLAN VIEW WITH DIMENSIONS OF SALT CREEK BRIDGE



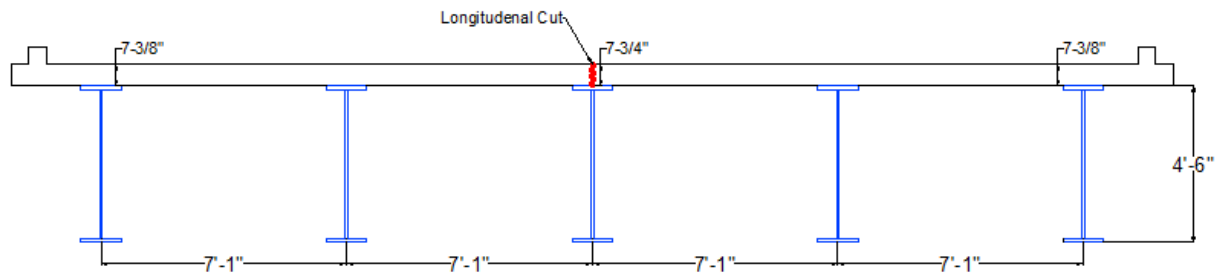

FIGURE 3-25: CROSS SECTIONAL VIEW WITH GIRDER SPAN AND THICKNESS OF DECK

The location of transverse and longitudinal saw cuts made can be shown as the red dashed lines in Figure 3-24 and Figure 3-25. The 5 ft by 15 ft concrete slabs were lifted with the slab crab, seen in Figure 3-26. Small concrete chunks fell to the ground from jack hammering the guard rail (Figure 3-27).



FIGURE 3-26: SLAB CRAB LIFTING DECK SLAB FROM WEST TO EAST



FIGURE 3-27: CONCRETE PIECES FELL TO THE WATERWAY UNDERNEATH

The lessons learned from this investigation were how to maximize efficiency with a non-composite bridge and when environmental restrictions exist. Longitudinal saw cutting is not restricted by girder line with a non-composite bridge. Deck panels can be saw cut in very large segments, only restricted by the lifting capacity of the excavator/crane.

### *3.4 PACIFIC ST. AND 106<sup>TH</sup> STREET BRIDGE*

The purpose of this investigation was to observe sequencing of tasks in an area with high traffic volume and environmental restrictions. Also, deck removal methods were evaluated when steel I-girders with short steel stud shear connectors are used. The Pacific St. Bridge at 106<sup>th</sup> Street is located over the Big Papillion Creek. The operations were not only restricted environmentally, but also conducted on one side of the bridge, while the other side was open to two-way heavy traffic. Figure 3-28 shows the plan view of Pacific St. Bridge.

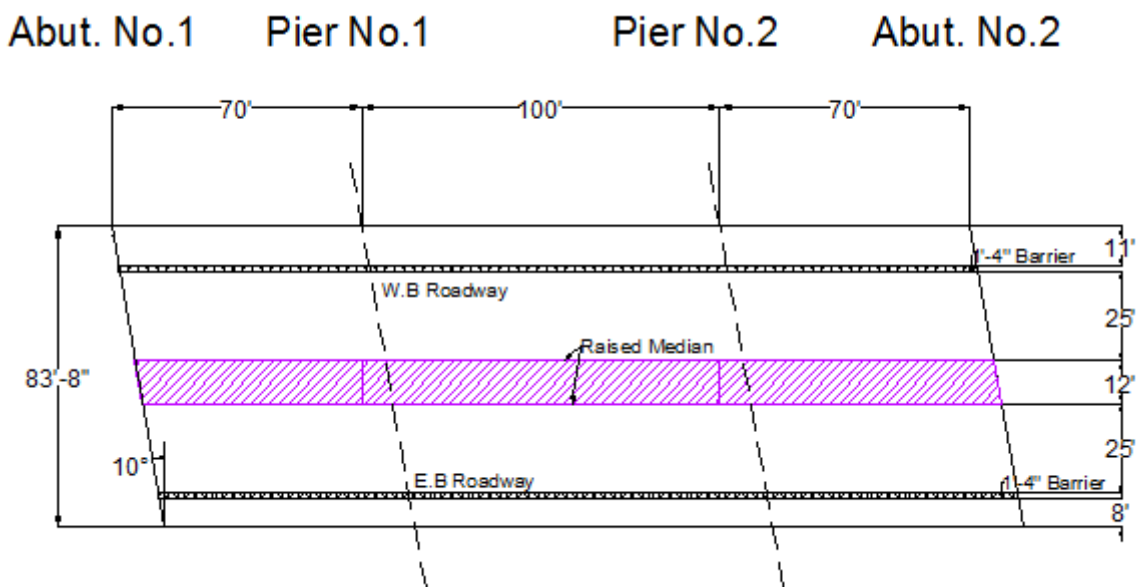

FIGURE 3-28: PLAN VIEW AND DIMENSIONS OF PACIFIC ST. BRIDGE

This project included deck replacement and widening of the bridge. The bridge is 240 ft long, 83'-8" wide, and has three spans; 70 ft, 100 ft, and 70 ft, respectively. The composite bridge consists of W36 steel girders. Furthermore, because of environmental restrictions, the deck panels needed to be lifted away from the waterway. For re-decking, the steel girders will be reused after sandblasting and repainting them.

The sequencing of tasks was important for efficiency and to minimize the duration of closed roadway. After clearing the area, closing off the street, and moving equipment into place, the contractor first set up safety lines for workers. The second task performed was to longitudinally saw cut for the full depth along the full length. Two longitudinal saw cuts were made at each girder line, each saw-cut made in the center of the outer most shear stud to the center shear stud. The shear connectors used for composite action are three short shear studs spaced along the full length of the girders.

After longitudinal saw cutting, the overhang on each side of the barriers or guard rail were jackhammered and broken off. This was the biggest contributor of concrete chunks that fell to the ground below. Next, transverse saw cuts were done along the full width at an increment of 5 ft, shown in Figure 3-29.

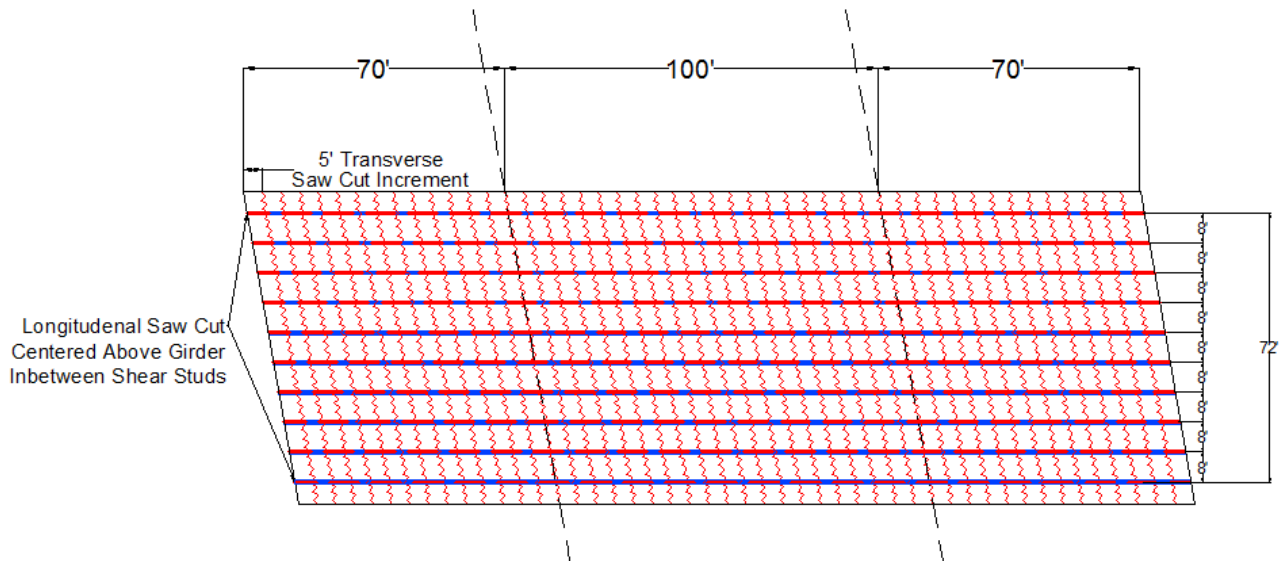

FIGURE 3-29: GIRDER LAYOUT AND SAW CUT LOCATION OF PACIFIC ST. BRIDGE

Next, the deck panels were lifted using a large crane. The crane's capabilities allowed lifting panels at mid-span of the bridge. The deck panels popped off from the shear connectors that were still embedded in the deck. For efficiency, a jack hammer attached to a backhoe was used to jackhammer most of the concrete above the girder. However, the remaining concrete that stayed around the shear connectors needed to be removed and cleaned up using hand chippers. The girders were then able to be removed for further sandblasting and repainting. The total deck removal process took two weeks to complete.



FIGURE 3-30: WORKERS USING HAND CHIPPERS TO REMOVE CONCRETE AROUND SHEAR STUDS



FIGURE 3-31: VIEW LOOKING WEST AFTER COMPLETED DECK REMOVAL

The lessons learned from this investigation were the sequencing of tasks required for efficient and smooth deck removal. The environmental restrictions and high traffic area dictated the methods and equipment used.

## Chapter 4. COST DATA

The purpose of this chapter is to obtain cost data for deck removal practices. This includes the cost of saw cutting, jack hammering, and hydro-demolition for deck removal. The costs is obtained from national average cost data and also local contractors and NDOR contracts.

The national average cost is obtained from the RSMeans Heavy Construction Cost Data publication, which has been engaged in publishing construction cost in North America for more than 70 years (Spenser, 2010). The national average cost obtained from the 2010 cost data is shown in Table 4-1, which includes 10% overhead and profit.

TABLE 4-1: RSMEANS 2010 COST DATA FOR DECK REMOVAL METHODS

| Job Type                                                                                         |                                                 | Total Incl O&P | Unit |
|--------------------------------------------------------------------------------------------------|-------------------------------------------------|----------------|------|
| Hydro-demolition                                                                                 | 4000 psi, 8" depth                              | <b>\$15.13</b> | S.F. |
| Concrete Slab Saw Cutting                                                                        | Concrete Slabs with 8" thickness                | <b>\$7.34</b>  | L.F. |
| Concrete Jack Hammering for 8 in. deck (excludes saw cutting, torch cutting, loading or hauling) | Break up into small pieces, minimum reinforcing | <b>\$2.38</b>  | S.F. |
|                                                                                                  | Average reinforcing                             | <b>\$3.56</b>  | S.F. |
|                                                                                                  | Maximum reinforcing                             | <b>\$7.14</b>  | S.F. |

Hawkins Construction Co. is a local bridge contractor who provided estimates on bridge deck removal methods. These methods include break and fall, longitudinally saw cutting and lifting deck panels, and hand removal with jack hammering on top of girders. The break and fall method is used when no environmental restrictions exist and when bridge girders are not to be re-decked. The cost of this method averages \$0.99/S.F. The saw cutting and lifting of panels between girders is used when environmental restrictions exist. This method averages \$3.16/S.F. The jack hammering method is used to remove

the deck on top of the girder for re-decking purposes. This method averages \$15.73/S.F, which is almost five times the cost of saw cutting due to the large number of man-hours involved. Figure 4-1 shows the cost of each method in dollars per square foot of deck. These estimates were provided by averaging the cost incurred in several projects by the same contractor.

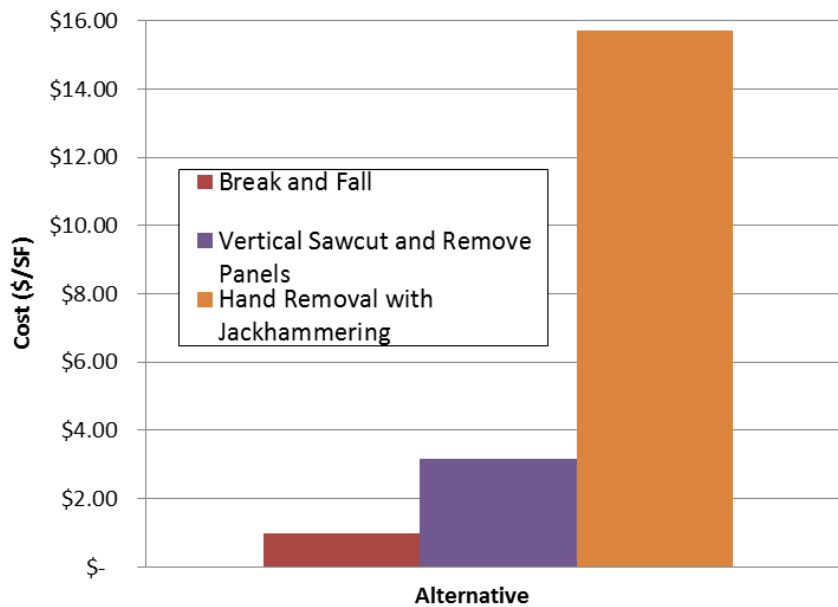

FIGURE 4-1: ILLUSTRATION OF COST VS. TYPE OF METHOD USED IN DECK REMOVAL

The obtained cost data is applied to Camp Creek Bridge presented in the previous chapter. The three methods used for deck removal on top of the girders are analyzed as following:

1. Removal of a 14 in. wide x 5 ft long x 8 in. deep strip with saw cuts directly outside shear connectors. This is an area of 5.83 ft<sup>2</sup> of deck to jack hammer.

2. Removal of a 3 ft – 2 in. wide x 4 ft – 10 in. long x 8 in. deep strip with saw cuts at 1 ft away from stirrup legs. This is an area of 15.30 ft<sup>2</sup> of deck.
3. Removal of a 3 ft – ½ in. wide x 4 ft – 10 in. long x 8 in. deep strip with saw cuts at directly outside shear connectors and also saw cuts at approximately 1 ft away from stirrup legs. This is an area of 14.70 ft<sup>2</sup> of deck.

Table 4-2 shows the total cost for each method estimated using the national average prices. Costs of deck removal varies depending on location and access to job site.

TABLE 4-2: COST ANALYSIS OF CAMP CREEK METHODS

|          | Amount to Saw Cut (L.F.) | Cost of Saw Cutting | Area of Deck to Jack Hammer (S.F) | Cost of Jack Hammering | Total Cost      |
|----------|--------------------------|---------------------|-----------------------------------|------------------------|-----------------|
| Method 1 | 10.00                    | \$73.40             | 5.83                              | \$20.73                | <b>\$94.13</b>  |
| Method 2 | 9.67                     | \$70.98             | 15.30                             | \$54.40                | <b>\$125.38</b> |
| Method 3 | 19.33                    | \$141.91            | 14.70                             | \$52.27                | <b>\$194.17</b> |

This table indicates that Method 1 is the most cost effective method, while Method 3 is the least. This is probably due to the very small area used in this analysis. As the deck area increases, the relative cost of saw cutting to jackhammering will change, which may alter this conclusion.



## Chapter 5. ANALYTICAL INVESTIGATIONS

### *5.1 INTRODUCTION*

The purpose of this investigation is to analytically evaluate the effect of top flange width on the flexural capacity, horizontal shear capacity, and deflection of the girder during construction and at service. This investigation aims to present whether cutting/damaging the wide and thin top flange of bridge concrete I-girders has a significant effect on the structural performance of the bridge. A reduction in top flange width by saw cutting will significantly reduce the amount of deck to be jackhammered, which consequently reduces removal cost. Because cross bracing placed between girders after erection is not removed with the deck, the lateral stability of the girder is not a concern even when the top flange width is significantly reduced. Therefore no lateral stability analysis is conducted in this investigation.

In this chapter two examples are investigated; a bridge with low span-to-depth ratio (14.5) and bridge with high span-to-depth ratio (33.53). For each example, calculations are made to compare the flexural capacity, horizontal shear capacity and deflection of cut flange versus full flange girder.

### *5.2 COMPARISON OF GEOMETRIC PROPERTIES*

Saw cutting the top flange reduces the area, inertia, and section modulus of I-girders. The geometric properties of NU girders with a full flange and cut flange are shown in Table 5-1. Geometric properties are calculated assuming reduction of top flange

by 50%, or a longitudinal cut at 1 ft from flange edge on either side as shown in Figure 5-

1.

TABLE 5-1: NU GIRDER FULL FLANGE AND CUT FLANGE PROPERTIES

| NU Girder Properties - Full Flange Section |                 |                       |                        |                           |                         |                         |                         |                      |                                      |                                      |
|--------------------------------------------|-----------------|-----------------------|------------------------|---------------------------|-------------------------|-------------------------|-------------------------|----------------------|--------------------------------------|--------------------------------------|
| Section                                    | Height<br>(in.) | Web<br>Width<br>(in.) | Top<br>Flange<br>Width | Bottom<br>Flange<br>Width | A<br>(in <sup>2</sup> ) | Y <sub>b</sub><br>(in.) | Y <sub>t</sub><br>(in.) | I (in <sup>4</sup> ) | S <sub>b</sub><br>(in <sup>3</sup> ) | S <sub>t</sub><br>(in <sup>3</sup> ) |
| NU 900                                     | 35.4            | 5.9                   | 48.2                   | 38.4                      | 648.1                   | 16.1                    | 19.3                    | 110,262              | 6849                                 | 5713                                 |
| NU 1100                                    | 43.3            | 5.9                   | 48.2                   | 38.4                      | 694.6                   | 19.6                    | 23.7                    | 182,279              | 9300                                 | 7691                                 |
| NU 1350                                    | 53.1            | 5.9                   | 48.2                   | 38.4                      | 752.7                   | 24.0                    | 29.1                    | 302,334              | 12597                                | 10389                                |
| NU 1600                                    | 63.0            | 5.9                   | 48.2                   | 38.4                      | 810.8                   | 28.4                    | 34.6                    | 458,482              | 16144                                | 13251                                |
| NU 1800                                    | 70.9            | 5.9                   | 48.2                   | 38.4                      | 857.3                   | 32.0                    | 38.9                    | 611,328              | 19104                                | 15715                                |
| NU 2000                                    | 78.7            | 5.9                   | 48.2                   | 38.4                      | 903.8                   | 35.7                    | 43.0                    | 790,592              | 22145                                | 18386                                |

| NU Girder Properties - Cut Flange Section |                 |                       |                        |                           |                         |                         |                         |                      |                                      |                                      |
|-------------------------------------------|-----------------|-----------------------|------------------------|---------------------------|-------------------------|-------------------------|-------------------------|----------------------|--------------------------------------|--------------------------------------|
| Section                                   | Height<br>(in.) | Web<br>Width<br>(in.) | Top<br>Flange<br>Width | Bottom<br>Flange<br>Width | A<br>(in <sup>2</sup> ) | Y <sub>b</sub><br>(in.) | Y <sub>t</sub><br>(in.) | I (in <sup>4</sup> ) | S <sub>b</sub><br>(in <sup>3</sup> ) | S <sub>t</sub><br>(in <sup>3</sup> ) |
| NU 900                                    | 35.4            | 5.9                   | 24.1                   | 38.4                      | 583.5                   | 14.1                    | 21.3                    | 86,550               | 6151                                 | 4058                                 |
| NU 1100                                   | 43.3            | 5.9                   | 24.1                   | 38.4                      | 629.9                   | 17.2                    | 26.1                    | 145,744              | 8493                                 | 5576                                 |
| NU 1350                                   | 53.1            | 5.9                   | 24.1                   | 38.4                      | 687.5                   | 21.2                    | 32.0                    | 245,547              | 11610                                | 7685                                 |
| NU 1600                                   | 63.0            | 5.9                   | 24.1                   | 38.4                      | 745.7                   | 25.3                    | 37.7                    | 378,927              | 14960                                | 10059                                |
| NU 1800                                   | 70.9            | 5.9                   | 24.1                   | 38.4                      | 792.1                   | 28.7                    | 42.2                    | 510,897              | 17777                                | 12118                                |
| NU 2000                                   | 78.7            | 5.9                   | 24.1                   | 38.4                      | 837.9                   | 32.2                    | 46.5                    | 665,007              | 20672                                | 14292                                |

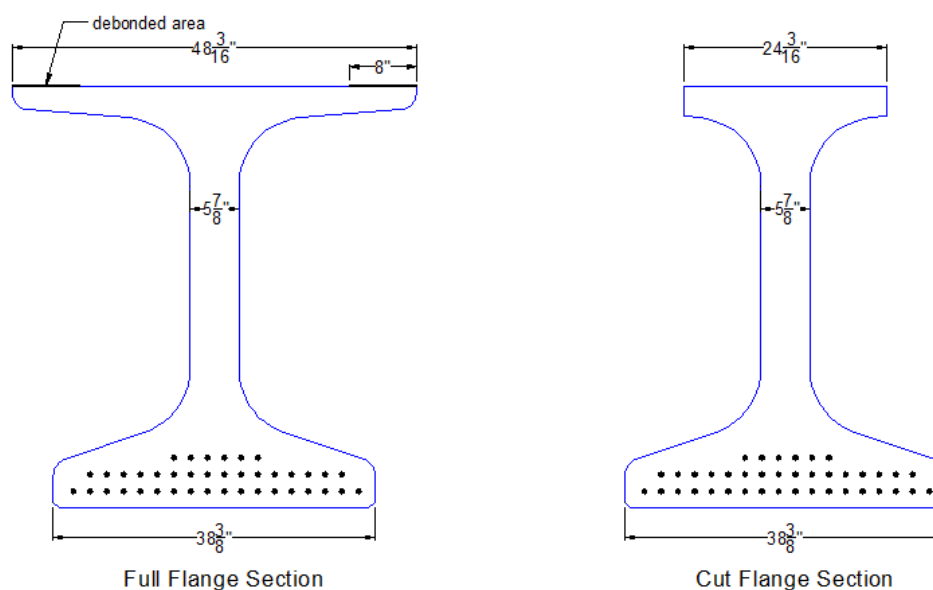

FIGURE 5-1: NON-COMPOSITE CROSS-SECTION OF A FULL FLANGE AND CUT FLANGE SECTION

Table 5-2 lists the percent of reduction in all geometric properties of non-composite NU girder when the top flange width is reduced by 50. The range of reduction in area is from 7.3% to 10%, while the range of reduction in moment of inertia is from 15.9% to 21.5%.

TABLE 5-2: EFFECT OF CUTTING TOP FLANGE ON NU GIRDER SECTIONS

| Section | Effect of Cutting Top Flange on NU Girder Properties |                                                 |                                                |                              |                                                        |                                                        |
|---------|------------------------------------------------------|-------------------------------------------------|------------------------------------------------|------------------------------|--------------------------------------------------------|--------------------------------------------------------|
|         | Percent Area Reduction                               | Percent Reduction in Centroid (Y <sub>b</sub> ) | Percent Increase in Centroid (Y <sub>t</sub> ) | Percent Reduction in Inertia | Percent Reduction in Section Modulus (S <sub>b</sub> ) | Percent Reduction in Section Modulus (S <sub>t</sub> ) |
| NU 900  | 10.0                                                 | 12.6                                            | 10.5                                           | 21.5                         | 10.2                                                   | 29.0                                                   |
| NU 1100 | 9.3                                                  | 12.4                                            | 10.3                                           | 20.0                         | 8.7                                                    | 27.5                                                   |
| NU 1350 | 8.7                                                  | 11.9                                            | 9.8                                            | 18.8                         | 7.8                                                    | 26.0                                                   |
| NU 1600 | 8.0                                                  | 10.8                                            | 8.9                                            | 17.4                         | 7.3                                                    | 24.1                                                   |
| NU 1800 | 7.6                                                  | 10.2                                            | 8.4                                            | 16.4                         | 6.9                                                    | 22.9                                                   |
| NU 2000 | 7.3                                                  | 9.9                                             | 8.2                                            | 15.9                         | 6.7                                                    | 22.3                                                   |

### 5.3 EXAMPLE 1: ANALYSIS OF CAMP CREEK BRIDGE

#### 5.3.1 BRIDGE PARAMETERS

The Camp Creek Bridge over I-80 in Lancaster County, NE, is analyzed using full and cut flange girders. The bridge has 3 spans with 4 girder lines per span. Table 5.3

Girder cross-sectional dimensions for composite sections are shown in Figure 5-2. The bridge has girder spacing of 12 ft. Camp Creek bridge parameters are shown in Table 5-3.

TABLE 5-3: PARAMETERS OF THE CAMP CREEK BRIDGE

| Parameter                   | Symbol        | Unit              | Value |
|-----------------------------|---------------|-------------------|-------|
| No. of Girder Lines         | x             | -                 | 4     |
| Girder spacing              | s             | ft                | 12    |
| Girder span length          | L             | ft                | 52.5  |
| Girder weight               | $W_t$         | k/ft              | 0.724 |
| Deck thickness              | t             | in.               | 8     |
| Weight of concrete          | $W_c$         | k/ft <sup>3</sup> | 0.15  |
| Girder compressive strength | $f_c'$ girder | ksi               | 8     |
| Deck compressive strength   | $f_c'$ deck   | ksi               | 4     |

Cross-sectional geometric properties of non-composite and composite sections are presented in Table 5-4. Composite cross-sections to be analyzed are shown in Figure 5-2.

TABLE 5-4: FULL AND CUT FLANGE CROSS-SECTIONAL PROPERTIES

| Girder Cross-Sectional Property | Girder With Full Flange |                   | Girder With Cut Flange |                   |
|---------------------------------|-------------------------|-------------------|------------------------|-------------------|
|                                 | Precast Section         | Composite Section | Precast Section        | Composite Section |
| A (in <sup>2</sup> )            | 692                     | 1844              | 618                    | 1770              |
| Ig (in <sup>4</sup> )           | 180,542                 | 523,623           | 139,301                | 521,735           |
| Yb (in.)                        | 19.40                   | 32.90             | 16.70                  | 32.50             |
| Yt (in.)                        | 23.92                   | 14.48             | 26.59                  | 14.68             |
| Sb (in <sup>3</sup> )           | 9,306                   | 15,916            | 8,341                  | 16,053            |
| St (in <sup>3</sup> )           | 7,547                   | 36,174            | 5,239                  | 35,547            |

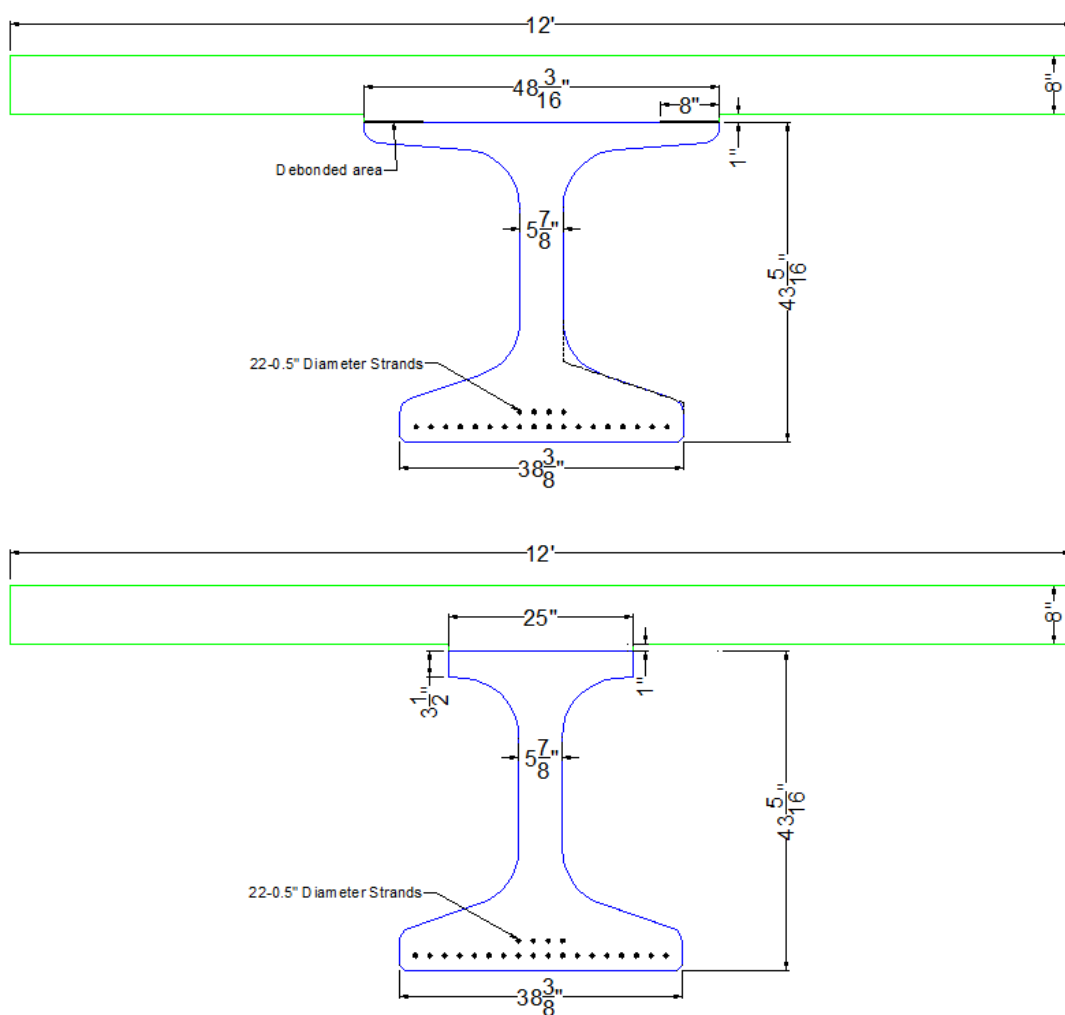

FIGURE 5-2: NU1100 GIRDER COMPOSITE CROSS-SECTIONAL DIMENSIONS

### 5.3.2 EFFECT OF FLANGE WIDTH REDUCTION ON FLEXURAL CAPACITY AND DEFLECTION

This section outlines the analytical investigation of effect of a reduced flange width on flexural capacity. NU1100 girders use 22 - 0.5 in. diameter strands and are tensioned to 75% of ultimate stress of 270 ksi. A conservative assumption for prestressing losses of 20% is used. The effective prestressing force after all losses is 549 kips.

Applied moments acting on the girder during construction and at service are analyzed. This includes dead load due to girder self-weight, deck-weight, weight due to guardrails, wearing surface, and any contributing dead loads acting on the super structure. Moments from dead loads and live load are considered.

For applied moments due to live load, the HL-93 live load model proposed by AASHTO is used. Table 5-5 shows the calculated applied moments due to dead and live loads. There is no significant difference in applied moment values due to the reduction of flange width.

TABLE 5-5: CALCULATED DEAD AND LIVE LOAD MOMENTS

| Parameter                        | Symbol     | Unit | Full Flange Girder | Cut Flange Girder |
|----------------------------------|------------|------|--------------------|-------------------|
| Moment due to Girder Self-Weight | $M_{s.w.}$ | k-ft | <b>249</b>         | <b>224</b>        |
| Moment due to Deck Self-Weight   | $M_d$      | k-ft | <b>413</b>         | <b>413</b>        |
| Moment due to Guard Rail         | $M_r$      | k-ft | <b>68</b>          | <b>68</b>         |
| Moment due to Wearing Surface    | $M_{w.s.}$ | k-ft | <b>81</b>          | <b>81</b>         |
| Dist. Factor                     | DF         | -    | 1.04               | 1.04              |
| Moment due to Live Load          | $M_{LL}$   | k-ft | <b>1161</b>        | <b>1160</b>       |

The demand at each phase is calculated using AASHTO LRFD specifications. The strength limit state used is Strength I for basic load combination relating to the

normal vehicular use of the bridge without wind. Load factor for permanent loads,  $\phi_p$ , is a value of 1.25 (AASHTO, 2007).

The demand is compared against girder capacity calculated for composite and non-composite sections. Strain compatibility concepts are used to calculate full flange girder capacity and cut flange girder capacity under each loading phase. The structural demand and capacity are compared in Table 5-6. The demand presented is at mid-span during construction and under service loads.

TABLE 5-6: CAPACITY/DEMAND COMPARISON OF FULL FLANGE AND CUT FLANGE GIRDER

SECTIONS

| Camp Creek Bridge NU1100 Girder (52.5 ft span) |                    |           |                   |           |
|------------------------------------------------|--------------------|-----------|-------------------|-----------|
|                                                | Full Flange Girder |           | Cut Flange Girder |           |
|                                                | Non-Composite      | Composite | Non-Composite     | Composite |
| Nominal Moment Capacity $M_n$ (k-ft)           | 2,995              | 3,636     | 2,754             | 3,636     |
| Demand (k-ft)                                  | 712                | 2,904     | 685               | 2,875     |
| Ratio                                          | 4.21               | 1.25      | 4.02              | 1.26      |
| L.L. Deflection at Mid-span (in.)              | -                  | 0.216     | -                 | 0.217     |

The percent reduction in nominal flexural capacity due to cutting of the flange is 8% of non-composite section during construction. There is no reduction in capacity after deck and girder become a composite section.

The deflection due to live load moment at mid-span is compared for the full flange section and cut flange section. The composite section inertia values are relatively the same for the full flange and cut flange girder cross-sections, which gives close values for service load deflections. Deflection values are all within the limit of  $1/400$ .

As presented in the table, the flexural capacity of the cut flange girder highly exceeds the demand at construction, which is the critical loading stage. This is the case for the 52 ft – 6 in. long span girder, whereas a NU1100 girder can span much longer.

Figure 5-3 shows a graph of the capacity/demand ratio at each critical stage for the full flange section and cut flange section. The ratio in all loading stages is greater than 1.0, which is considered adequate.

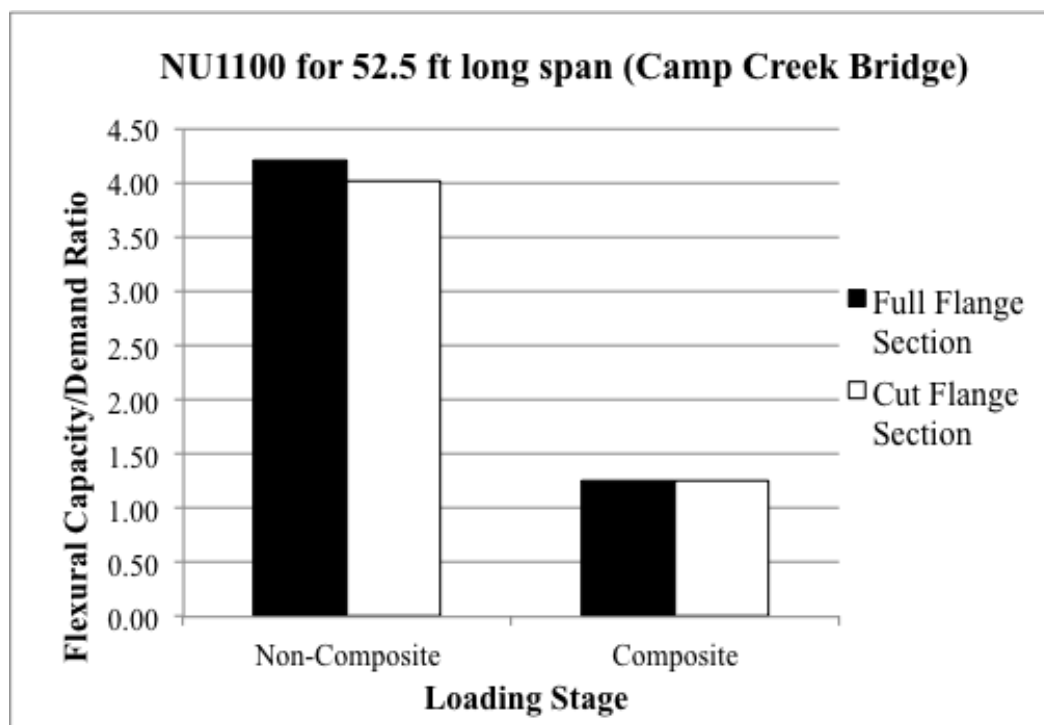

FIGURE 5-3: CAPACITY/DEMAND RATIO FOR NU1100 AT ALL LOADING STAGES

Because of the short span, the girder does not experience moment values close to the nominal capacity. However, this may not always be the case.

Analytical steps are taken in satisfying serviceability requirements. Stresses at the top and bottom fibers are checked at different loading stages. Stress values are checked under construction loads and under service loads.



AASHTO LRFD Specifications limit states are used. Maximum compression is checked under Service I limit states and maximum tension is checked under Service III limit states. The difference between Service I and Service III limit states is that Service I has a limit state of 1.0 for live load whereas Service III has a limit state of 0.8 for live load.

From Table 5.9.4.2.1-1 and Table 5.9.4.2.2-1 compressive stress limits and tensile stress limits are obtained. For compressive stress, the limit due to the sum of effective prestress, permanent loads, and transient loads and during shipping and handling is  $0.60 * f'_c$  (AASHTO, 2007). For tensile stress, the limit in prestressed concrete after losses for fully prestressed components in bridges, which include bonded prestressing tendons and are subjected to not worse than moderate corrosion conditions, shall be taken as  $0.19 * \sqrt{f'_c}$  (AASHTO, 2007).

Table 5-7 summarizes the results of the analysis. As presented in the table, the serviceability requirements assuming uncracked sections are met.

TABLE 5-7: MIDSPAN CRITICAL STRESSES FOR 52 FT LONG NU1100 GIRDER

| Load                           | Camp Creek Bridge Midspan Critical Service Stresses |             |             |              |                        |             |             |              |
|--------------------------------|-----------------------------------------------------|-------------|-------------|--------------|------------------------|-------------|-------------|--------------|
|                                | Girder With Full Flange                             |             |             |              | Girder With Cut Flange |             |             |              |
|                                | At Construction                                     |             | At Service  |              | At Construction        |             | At Service  |              |
|                                | ft (ksi)                                            | fb (ksi)    | ft (ksi)    | fb (ksi)     | ft (ksi)               | fb (ksi)    | ft (ksi)    | fb (ksi)     |
| P/A                            | 0.79                                                | 0.79        | 0.79        | 0.79         | 0.88                   | 0.88        | 0.88        | 0.88         |
| (Pc*e)/Snon-com                | -1.23                                               | 1.00        | -1.23       | 1.00         | -1.50                  | 0.94        | -1.50       | 0.94         |
| Ms.w./Snon-com                 | 0.40                                                | -0.32       | 0.40        | -0.32        | 0.51                   | -0.32       | 0.51        | -0.32        |
| Md/Snon-com                    | 0.66                                                | -0.53       | 0.66        | -0.53        | 0.95                   | -0.59       | 0.95        | -0.59        |
| Mr/Scom                        | -                                                   | -           | 0.02        | -0.05        | -                      | -           | 0.02        | -0.05        |
| Mw.s./Scom                     | -                                                   | -           | 0.03        | -0.06        | -                      | -           | 0.03        | -0.06        |
| Ml.l/Scom                      | -                                                   | -           | 0.39        | -0.70        | -                      | -           | 0.39        | -0.69        |
| <b>Combined Stresses (ksi)</b> | <b>0.61</b>                                         | <b>0.93</b> | <b>1.04</b> | <b>0.12</b>  | <b>0.85</b>            | <b>0.90</b> | <b>1.29</b> | <b>0.10</b>  |
| <b>Limiting Stresses (ksi)</b> | 0.45*fc'                                            | 0.45*fc'    | 0.60*fc'    | 0.19*√(fc')  | 0.45*fc'               | 0.45*fc'    | 0.60*fc'    | 0.19*√(fc')  |
|                                | <b>3.60</b>                                         | <b>3.60</b> | <b>4.80</b> | <b>-0.54</b> | <b>3.60</b>            | <b>3.60</b> | <b>4.80</b> | <b>-0.54</b> |
|                                | <b>O.K.</b>                                         | <b>O.K.</b> | <b>O.K.</b> | <b>O.K.</b>  | <b>O.K.</b>            | <b>O.K.</b> | <b>O.K.</b> | <b>O.K.</b>  |

The results obtained for critical stresses for Service I limit state and for Service III limit state and are all within the limit for an uncracked section.

### 5.3.3 EFFECT OF FLANGE WIDTH REDUCTION ON HORIZONTAL SHEAR CAPACITY

This section analyzes the effect on cutting girder top flange on horizontal shear. The 2012 AASHTO Bridge Specifications are followed for calculations. By reducing flange width, the area of concrete engaged in horizontal shear transfer,  $A_{cv}$ , is reduced.

For the full flange girder,  $A_{cv}$  is the full concrete surface area of the flange minus the debonded area. The effective width,  $b_e$ , is shown below. The effective depth,  $d$ , is the same for both cases.  $A_{cv}$  is reduced by 25% when the flange is cut to a 2 ft width.

TABLE 5-8: PARAMETERS FOR HORIZONTAL SHEAR ANALYSIS ON NU1100

| Parameters | Full Flange Girder   | Cut Flange Girder    |
|------------|----------------------|----------------------|
| $b_v$      | 32 in.               | 24 in.               |
| $d_v$      | 44.7 in.             | 44.7 in.             |
| $A_{cv}$   | 1430 in <sup>2</sup> | 1073 in <sup>2</sup> |

The stirrup configuration of the Camp Creek girders is shown in Figure 5-4. The maximum interface reinforcement spacing is 2-#3 stirrups every 12 in. at mid-span and minimum spacing of 2 in. at the ends of the girder. Stirrup reinforcement area for 2#3 bars is 0.22 in<sup>2</sup>.

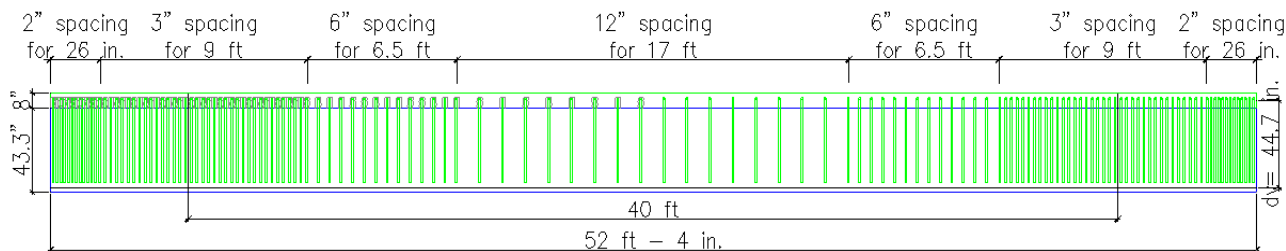

FIGURE 5-4: NU1100 STIRRUP CONFIGURATION

Nominal horizontal shear capacity values are calculated for distances from the mid-span in increments of 2 ft. Stirrup reinforcement area for 2#3 bars is 0.22 in<sup>2</sup>. The results are obtained and graphed in Figure 5-5. From the results, it is apparent that when cutting through the top flange, some horizontal shear capacity is lost due to a reduction in top flange width. The average percent loss in horizontal shear capacity over 24 ft from mid-span is 20.75%.

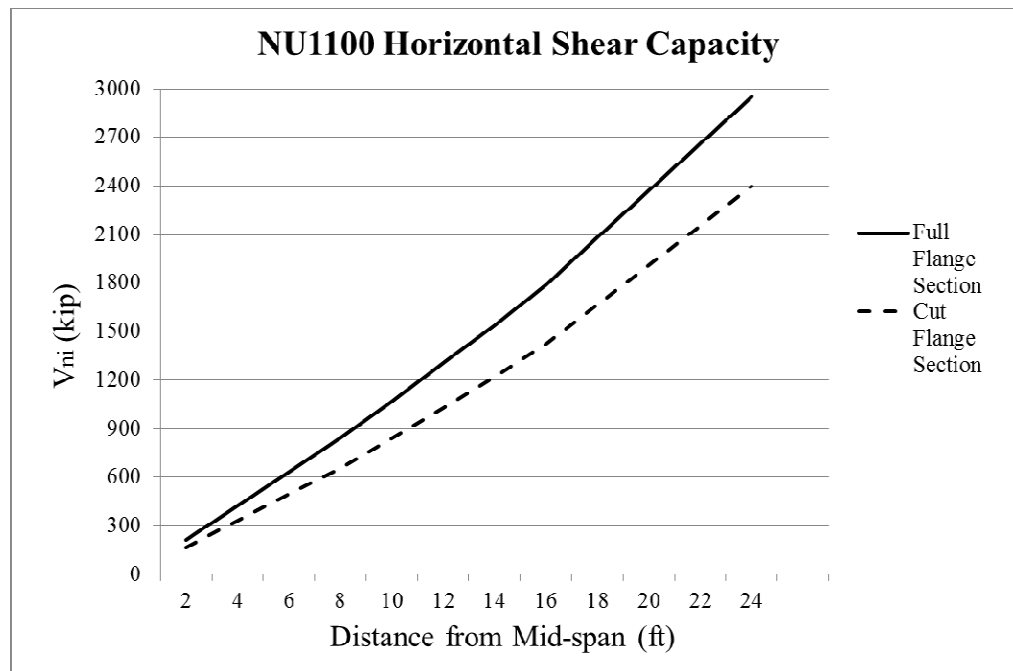

FIGURE 5-5: EFFECT OF CUTTING TOP FLANGE ON HORIZONTAL SHEAR CAPACITY FOR NU1100

## 5.4 EXAMPLE 2: OXFORD SOUTH BRIDGE

### 5.4.1 BRIDGE PARAMETERS

The second example is of bridge utilizing NU1350 girders. The span chosen for analysis is 140 ft long. The span-to-depth ratio is 33.53. With more than double the span-to-depth ratio from the previous example, this is a much less conservative case. The same analytical procedure is taken in analyzing the effect of cutting the top flange on flexural capacity, horizontal shear capacity, and mid-span deflection. The composite cross-sections of the NU1350 full flange and cut flange section is shown below in Figure 5-6. The bridge parameters are shown below in Table 5-9.

TABLE 5-9: PARAMETERS OF OXFORD SOUTH BRIDGE

| Parameter                   | Symbol        | Unit              | Value |
|-----------------------------|---------------|-------------------|-------|
| No. of Girder Lines         | x             | -                 | 4     |
| Girder spacing              | s             | ft                | 9     |
| Girder span length          | L             | ft                | 140   |
| Girder weight               | $W_t$         | k/ft              | 0.785 |
| Deck thickness              | t             | in.               | 8     |
| Weight of concrete          | $W_c$         | k/ft <sup>3</sup> | 0.15  |
| Girder compressive strength | $f_c'$ girder | ksi               | 9     |
| Deck compressive strength   | $f_c'$ deck   | ksi               | 4     |

Cross-sectional geometric properties for the case of a NU1350 girder with a full flange and cut flange section are shown in Table 5-10. In this example, the larger girder has slightly less of a reduction in properties than in the previous example. Composite cross-sections to be analyzed are shown in Figure 5-6.

TABLE 5-10: FULL AND CUT FLANGE CROSS-SECTIONAL DIMENSIONS

| Girder Cross-Sectional Property       | Girder With Full Flange |                   | Girder With Cut Flange |                   |
|---------------------------------------|-------------------------|-------------------|------------------------|-------------------|
|                                       | Precast Section         | Composite Section | Precast Section        | Composite Section |
| <b>A (in<sup>2</sup>)</b>             | 749.3                   | 1613.3            | 675.3                  | 1539.3            |
| <b>I<sub>g</sub> (in<sup>4</sup>)</b> | 298,886                 | 751,710           | 235,405                | 744,047           |
| <b>Y<sub>b</sub> (in.)</b>            | 23.7                    | 41.6              | 20.9                   | 41.3              |
| <b>Y<sub>t</sub> (in.)</b>            | 29.4                    | 19.5              | 32.5                   | 20.0              |
| <b>S<sub>b</sub> (in<sup>3</sup>)</b> | 12,611                  | 18,070            | 11,263                 | 18,016            |
| <b>S<sub>t</sub> (in<sup>3</sup>)</b> | 10,159                  | 38,505            | 7,251                  | 37,207            |

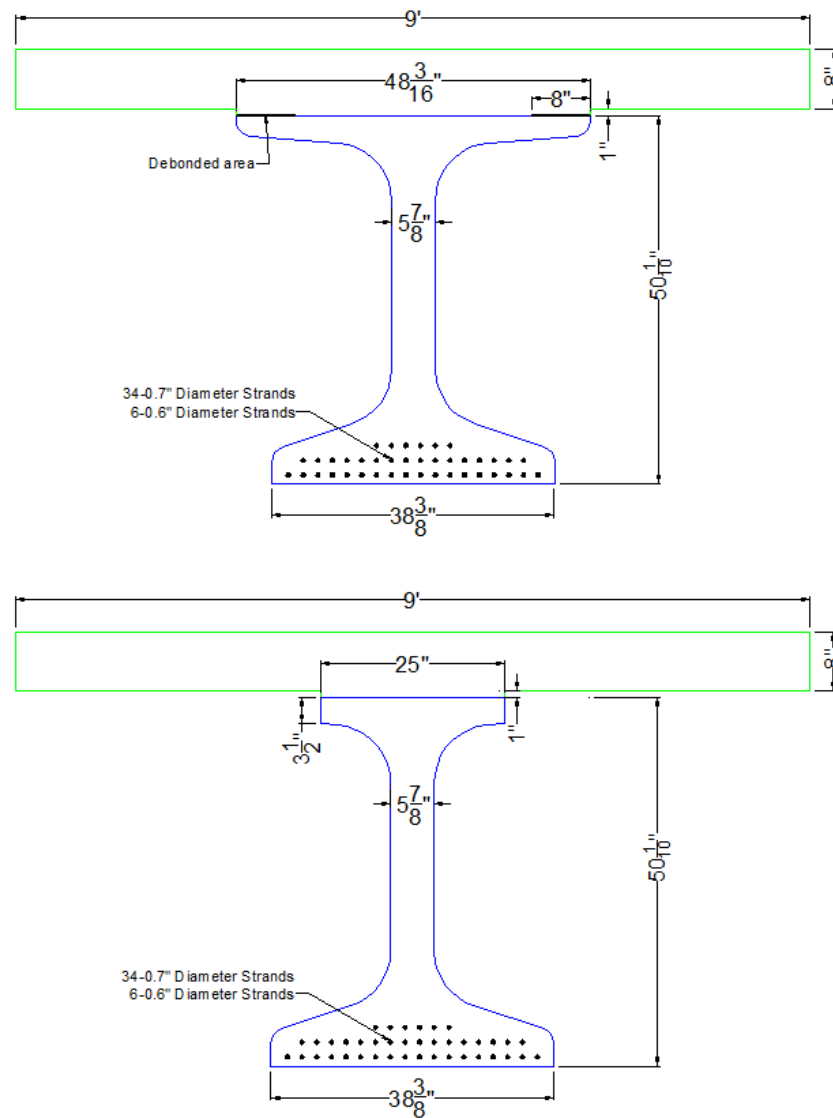

FIGURE 5-6: NU1350 GIRDER COMPOSITE CROSS-SECTIONAL DIMENSIONS

#### 5.4.2 EFFECT OF FLANGE WIDTH REDUCTION ON FLEXURAL CAPACITY AND DEFLECTION

The Oxford South Bridge is a 5 span bridge with 4 girder lines per span. Span lengths are 110 ft, 110 ft, 140 ft, 110 ft, and 110 ft respectively from the south abutment to the north abutment.

NU1350 girders are tensioned using 34-0.7 in. diameter strands and 6-0.6 in. diameter strands. With an assumption for prestress losses of 20%, the effective prestressing force is 1830 kips.

Dead load moments from the girder self-weight and from the deck are accounted for applied moments at construction. Dead load from guardrail, wearing surface, and live load using AASHTO HL-93 model are accounted for applied moments at service. The values for applied moments are in Table 5-11 below. For live load moment, the distribution factor for the full flange section and cut flange section are the same, despite the reduced inertia, area, and centroid of the section. The case for an interior bridge girder is assumed.

TABLE 5-11: CALCULATED DEAD AND LIVE LOAD MOMENTS

| <b>Parameter</b>                        | <b>Symbol</b>           | <b>Unit</b> | <b>Full Flange Girder</b> | <b>Cut Flange Girder</b> |
|-----------------------------------------|-------------------------|-------------|---------------------------|--------------------------|
| <b>Moment due to Girder Self Weight</b> | <b>M<sub>s.w.</sub></b> | <b>k-ft</b> | <b>1923</b>               | <b>1756</b>              |
| <b>Moment due to Deck Self Weight</b>   | <b>M<sub>d</sub></b>    | <b>k-ft</b> | <b>2205</b>               | <b>2205</b>              |
| <b>Moment due to Guard Rail</b>         | <b>M<sub>r</sub></b>    | <b>k-ft</b> | <b>490</b>                | <b>490</b>               |
| <b>Moment due to Wearing Surface</b>    | <b>M<sub>w.s.</sub></b> | <b>k-ft</b> | <b>441</b>                | <b>441</b>               |
| <b>Dist. Factor</b>                     | <b>DF</b>               | <b>-</b>    | <b>0.68</b>               | <b>0.68</b>              |
| <b>Moment due to Live Load</b>          | <b>M<sub>LL</sub></b>   | <b>k-ft</b> | <b>3082</b>               | <b>3081</b>              |

For the full flange section, the demand is 4,438 k-ft at construction and 10,832 k-ft at service. The capacity of the full flange section and cut flange section are compared against the demand in Table 5-12. At the critical stage at construction, the capacity/demand ratio is at 1.37 for a full flange section and 1.13 for the cut flange section.

TABLE 5-12: CAPACITY VS. DEMAND OF FULL FLANGE AND CUT FLANGE GIRDERS

| Oxford South Bridge NU1350 Girder (140 ft span) |                    |           |                   |           |
|-------------------------------------------------|--------------------|-----------|-------------------|-----------|
|                                                 | Full Flange Girder |           | Cut Flange Girder |           |
|                                                 | Non-Composite      | Composite | Non-Composite     | Composite |
| Nominal Moment Capacity $M_n$ (k-ft)            | 6,085              | 13,338    | 4,819             | 13,328    |
| Demand (k-ft)                                   | 4,438              | 10,832    | 4,258             | 10,651    |
| Ratio                                           | 1.37               | 1.23      | 1.13              | 1.25      |
| L.L. Deflection at Mid-span (in.)               | -                  | 2.68      | -                 | 2.71      |

The effect of cutting the top flange reduced the girder flexural capacity by 20.81% during construction. After the deck and girder become a composite section, there is no difference in capacity with a full flange or cut flange section. The critical stage in using this method is during re-decking processes with the weight of fresh concrete during construction. Table 5-6 graphs the capacity/demand ratio for the girder in this example, showing the ratio above 1.0 as adequately designed.

For mid-span deflection calculations, the values are the same for composite sections under live load moments at service. Deflection values are all within the limit of 1/400.



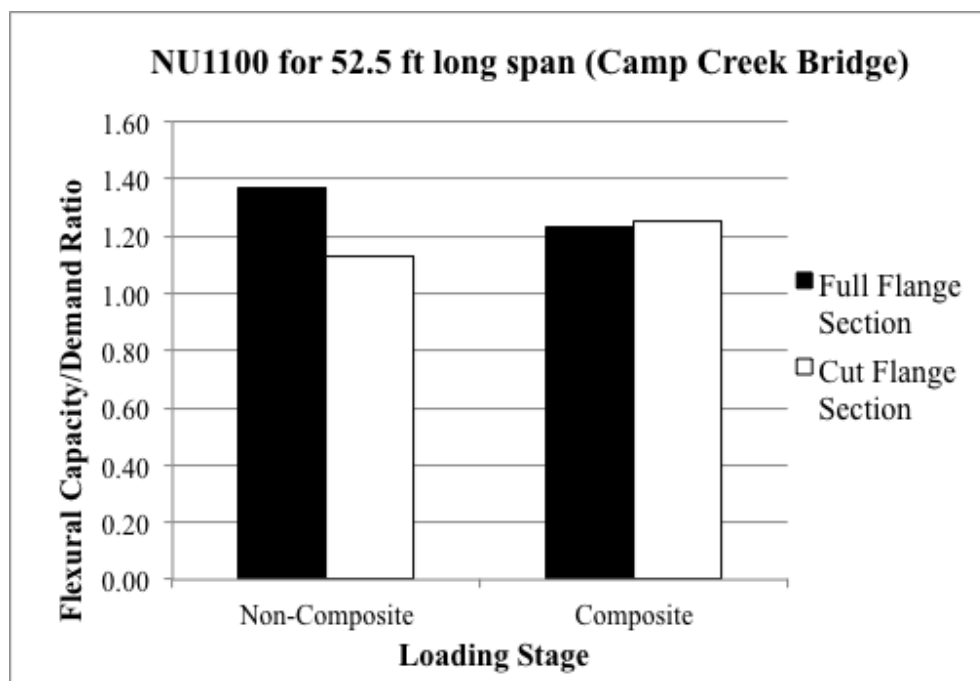

FIGURE 5-7: CAPACITY/DEMAND RATIO FOR NU1350 (OXFORD BRIDGE)

This extreme example shows that the deck removal method of cutting the top flange to reduce manual labor may not always be adequate for re-decking. Contractors must always take precautions and checks must always be made.

For serviceability requirements, AASHTO LRFD Specifications limit states are used. Maximum compression is checked under Service I limit states and maximum tension is checked under Service III limit states. For compressive stress, the limit during construction loading stages shall be taken as  $0.45f_c$ , and at final loading conditions as  $0.60f_c$  (AASHTO, 2007). For tensile stress, the limit shall be taken as  $0.45f_t$  (AASHTO, 2007). The critical service stresses exceed the limit for an uncracked section (Table 5-13).

TABLE 5-13: MIDSPAN CRITICAL STRESSES FOR 140 FT LONG NU1350 GIRDER

| Load                                     | Oxford Bridge Midspan Critical Service Stresses |             |             |              |                        |             |                 |              |
|------------------------------------------|-------------------------------------------------|-------------|-------------|--------------|------------------------|-------------|-----------------|--------------|
|                                          | Girder With Full Flange                         |             |             |              | Girder With Cut Flange |             |                 |              |
|                                          | At Construction                                 |             | At Service  |              | At Construction        |             | At Service      |              |
|                                          | ft (ksi)                                        | fb (ksi)    | ft (ksi)    | fb (ksi)     | ft (ksi)               | fb (ksi)    | ft (ksi)        | fb (ksi)     |
| P/A                                      | 2.60                                            | 2.60        | 2.60        | 2.60         | 2.88                   | 2.88        | 2.88            | 2.88         |
| (P <sub>e</sub> *e)/S <sub>non-com</sub> | -3.91                                           | 3.15        | -3.91       | 3.15         | -4.72                  | 3.04        | -4.72           | 3.04         |
| M <sub>s.w</sub> /S <sub>non-com</sub>   | 2.27                                            | -1.83       | 2.27        | -1.83        | 2.91                   | -1.87       | 2.91            | -1.87        |
| M <sub>d</sub> /S <sub>non-com</sub>     | 2.60                                            | -2.10       | 2.60        | -2.10        | 3.65                   | -2.35       | 3.65            | -2.35        |
| M <sub>r</sub> /S <sub>com</sub>         | -                                               | -           | 0.15        | -0.33        | -                      | -           | 0.16            | -0.33        |
| M <sub>w.s</sub> /S <sub>com</sub>       | -                                               | -           | 0.14        | -0.29        | -                      | -           | 0.14            | -0.29        |
| M <sub>l.l</sub> /S <sub>com</sub>       | -                                               | -           | 0.96        | -1.64        | -                      | -           | 0.99            | -1.64        |
| <b>Combined Stresses (ksi)</b>           | <b>3.56</b>                                     | <b>1.81</b> | <b>4.82</b> | <b>-0.44</b> | <b>4.71</b>            | <b>1.70</b> | <b>6.01</b>     | <b>-0.56</b> |
| <b>Limiting Stresses (ksi)</b>           | 0.45*fc'                                        | 0.45*fc'    | 0.60*fc'    | 0.19*√(fc')  | 0.45*fc'               | 0.45*fc'    | 0.60*fc'        | 0.19*√(fc')  |
|                                          | <b>4.05</b>                                     | <b>4.05</b> | <b>5.40</b> | <b>-0.57</b> | <b>4.05</b>            | <b>4.05</b> | <b>5.40</b>     | <b>-0.57</b> |
|                                          | <b>O.K.</b>                                     | <b>O.K.</b> | <b>O.K.</b> | <b>O.K.</b>  | <b>NOT O.K.</b>        | <b>O.K.</b> | <b>NOT O.K.</b> | <b>O.K.</b>  |

Service I limit state for compressive stresses is exceeded in the top flange at construction and service due to a reduction in flange width.

#### 5.4.3 EFFECT OF FLANGE WIDTH REDUCTION ON HORIZONTAL SHEAR CAPACITY

This section analyzes the effect of horizontal shear on Oxford South Bridge NU1350 girder. The analytical steps are the same as in the previous section, the only difference is the effective depth,  $d$ , is 53.81 in. instead of 44.7 in. and the stirrup distribution is slightly different. However, the effective width,  $b$ , is reduced the same amount by cutting the top flange, and therefore the engaged area  $A_v$  is reduced by 25%.

TABLE 5-14: PARAMETERS FOR HORIZONTAL SHEAR ANALYSIS ON NU1350

| Parameters | Full Flange Girder   | Cut Flange Girder    |
|------------|----------------------|----------------------|
| $b_v$      | 32 in.               | 24 in.               |
| $d_v$      | 53.81 in.            | 53.81 in.            |
| $A_{cv}$   | 1430 in <sup>2</sup> | 1073 in <sup>2</sup> |

The stirrup configuration of the Oxford South Bridge girders is shown in Figure 5-8. The maximum interface reinforcement spacing is 2-#3 stirrups every 12 in. at midspan and minimum spacing of 2 in. at the ends of the girder. Stirrup reinforcement area for 2#3 bars is 0.22 in<sup>2</sup>.

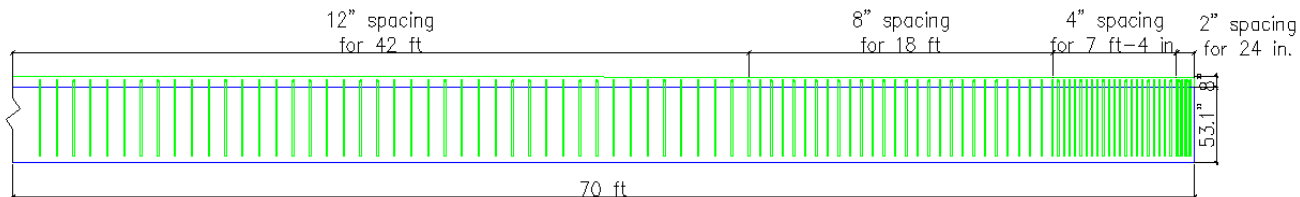

FIGURE 5-8: NU1350 STIRRUP DISTRIBUTION TO MIDSPAN OF GIRDER

Nominal horizontal shear capacity values are calculated for distances from the mid-span in increments of 2 ft. The results are obtained and graphed in Figure 5-9. From the results, the average percent loss in horizontal shear capacity over 24 ft from mid-span is 21.87%.

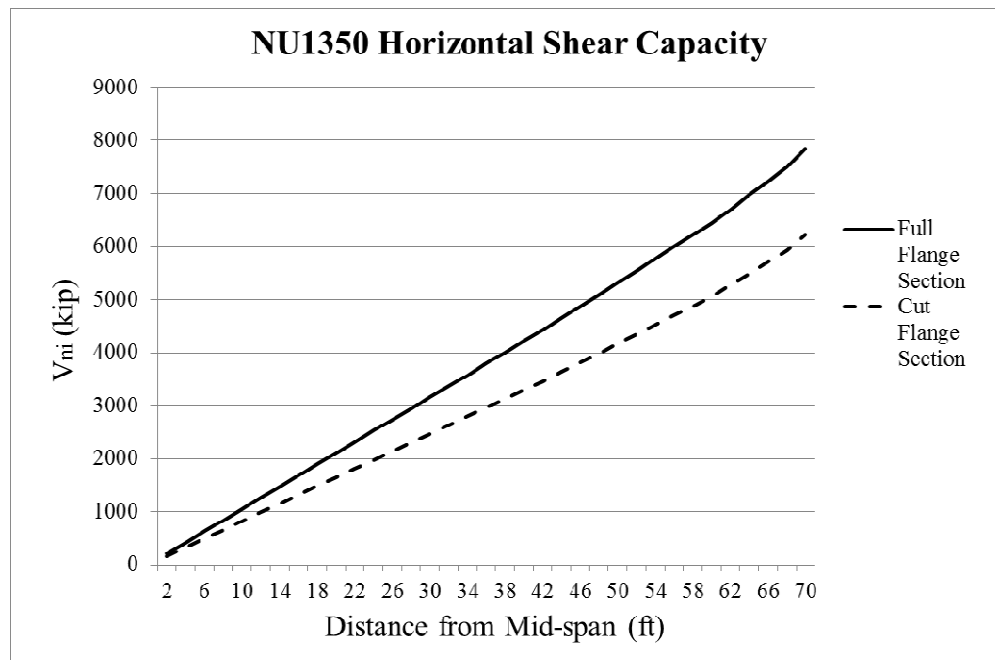

FIGURE 5-9: EFFECT OF CUTTING TOP FLANGE ON HORIZONTAL SHEAR CAPACITY FOR NU1350

## 5.5 CONCLUSION

From the analytical investigations of this chapter, the conclusions are the following:

1. For a low span-to-depth ratio scenario, a reduction in top flange width is not detrimental to girder capacity under service loads. However, there is a significant enough difference in capacity in a large span-to-depth ratio scenario to be inadequate.
2. There is a significant reduction in horizontal shear capacity due to flange width reduction of 50%, by about 20-22%.

## Chapter 6. EXPERIMENTAL INVESTIGATION

The purpose of the experimental investigation is threefold:

1. Evaluate the effect of the saw cutting/damaging the thin top flange on the girder flexural capacity and validating the analytical investigation presented in Chapter 5.
2. Evaluate the effect of the saw cutting/damaging the thin top flange on the horizontal shear capacity of the girder due to reduced interface surface area. Also the effect of partial removal of concrete around the shear connected will be evaluated.
3. Evaluate the efficiency of saw cutting and jackhammering operations to estimate the cost and duration of different removal methods.

Two 52 ft long girders were removed from the Camp Creek Bridge in the spring of 2012 and stored at Concrete Industries (CI) in Lincoln, NE to be used for this experimental investigations. The bridge deck was saw cut 8 in. from the edge of the top flange and the intermediate and end diaphragms were broken. Cross-sectional view of the bridge and bridge layout can be seen in the deck removal field investigation discussed in Section 3.1. Figure 6-1 shows one of the two NU1100 bridge girders used in the experimental investigation being lifted. Figure 6-2 shows the locations of the concrete cores drilled from the girder ends to evaluate the effectiveness of the debonding agents used between the girder top flange and the deck to facilitate deck removal without damaging the thin top flange.



FIGURE 6-1: CAMP CREEK GIRDERS LIFTED USING STRAPS



FIGURE 6-2: VIEW OF GIRDER END AND LOCATION OF TWO CONCRETE CORES

For each girder, four cores were drilled; two on each side of the two girders. On each side of the girders, one core was drilled in the bonded area, and one in the debonded area between the deck and the girder, shown in Figure 6-3. The cores taken in the bonded area remained in one piece, the cores taken in the debonded area split at the deck to girder interface. The orange-colored surface shown in Figure 6-4 is due to the use of debonding agent. Concrete cores were also used to estimate compressive strength of the two girders.



FIGURE 6-3: CORES TAKEN FROM BONDED ZONE (LEFT) AND FROM DEBONDED ZONE (RIGHT)

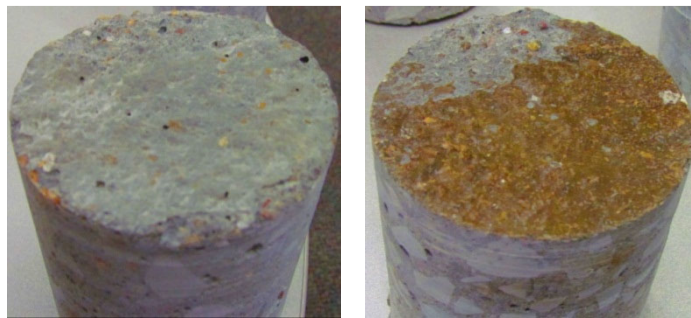

FIGURE 6-4: BONDED CONCRETE SURFACE (LEFT) AND DEBONDED CONCRETE SURFACE (RIGHT)

## *6.1 SPECIMEN PREPARATION*

### 6.1.1 SAW CUTTING SEQUENCE

The first step in preparing the two 52 ft long NU1100 girders for testing is to make longitudinal full depth saw cuts. The “full flange girder” was saw cut to the full depth of the deck while keeping the full flange intact. The “cut flange girder” was saw cut the full depth of the deck and through the flange. The effect of reduced flange width

on the flexural and horizontal shear capacities will be determined via testing. The dimensions of the girders with old deck are given in Figure 6-5. The deck is 5 ft- 4in. wide and 8 in. thick with an additional 1 in. haunch. The debonded zone is 8 in. wide strip from the edges of the 4 ft wide top flange.

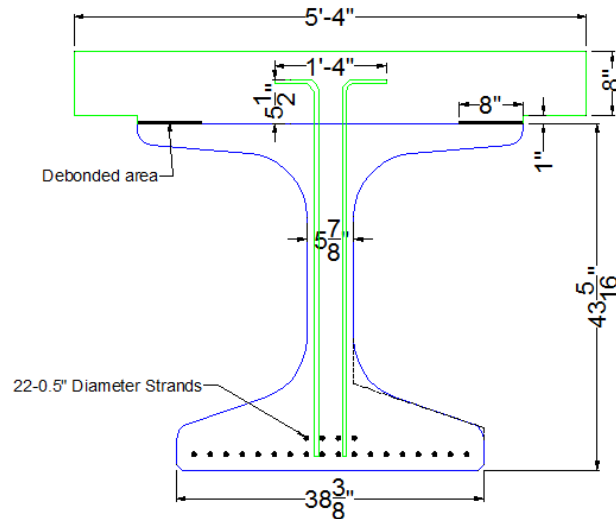

FIGURE 6-5: COMPOSITE DIMENSIONS OF GIRDERS TAKEN FROM CAMP CREEK BRIDGE

#### 6.1.1.1 FULL FLANGE GIRDER

For the full flange girder, saw cuts were made at the end of the debonded zone for the full depth of the deck to make the removal of the overhung portions of the deck easy to remove without damaging the girder top flange. Saw cutting closer to the shear connectors will minimize the amount of jack hammering needed, however removing the bonded deck would have been very difficult without damaging the top flange. Therefore, longitudinal saw cuts were made 1 ft – 4 in. from the center of the girder on either side. Figure 6-6 shows the location of each saw cut. The cuts were made to the full depth of about 9 in.



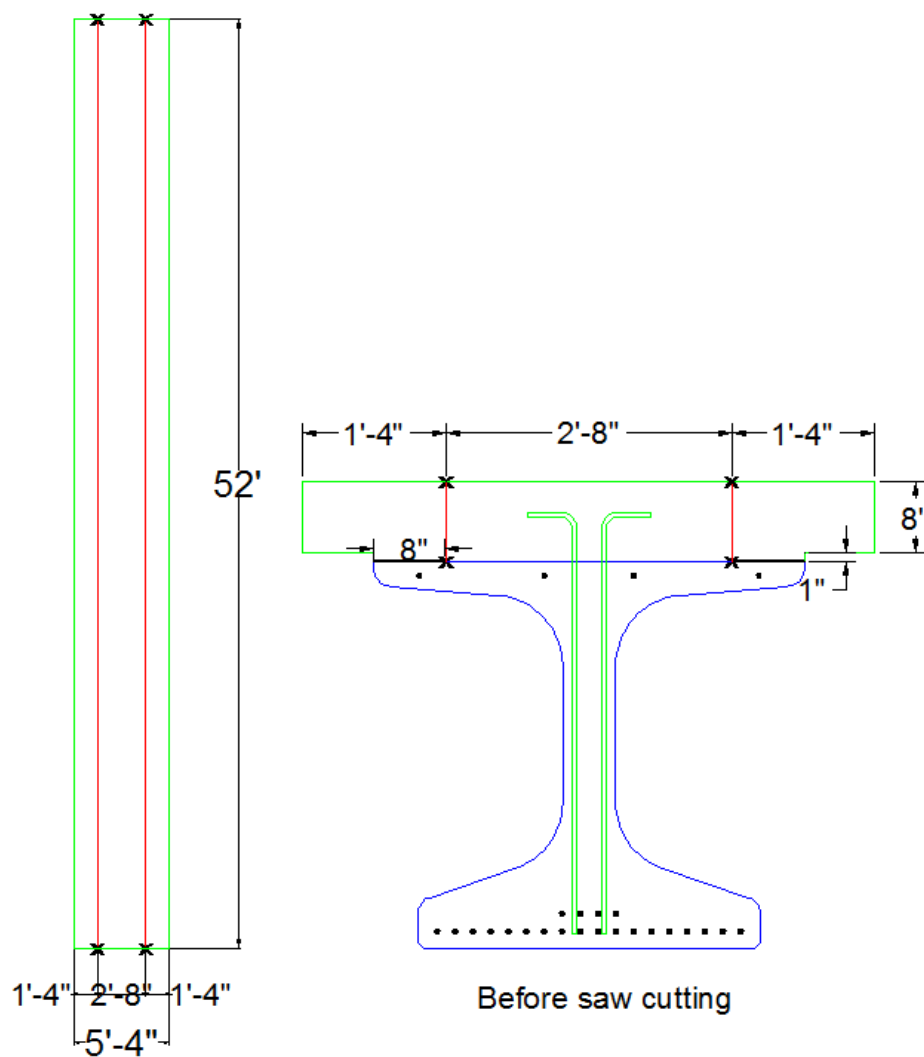

FIGURE 6-6: LOCATION OF LONGITUDENAL SAW CUTS ON GIRDER #1

The 9 in. deep longitudinal saw cuts required 3 passes, cutting down about 2-3 in. per pass. Figure 6-7 shows the longitudinal saw cuts being made on the full flange girder. Figure 6-8 shows a cross-sectional view after all longitudinal saw cuts were made.



FIGURE 6-7: WORKERS MAKING THREE PASSES FOR EACH SAW CUT LOCATION



FIGURE 6-8: FINISHED SAW CUTS (BEFORE END DECK SECTIONS WERE REMOVED)

#### 6.1.1.2 CUT FLANGE GIRDER

For the cut flange girder, the saw cuts were made to the full depth of the deck and through the top flange. The location of saw cuts was dictated by the width of the saw cutting machine, which is 25 in. Therefore, the flange width was reduced from 48 in to 25 in. Figure 6-9 shows the location of longitudinal saw cuts on the cut flange girder, which were made 12.5 in. from the center of the girder. The cuts were made to a depth of about 1 ft.

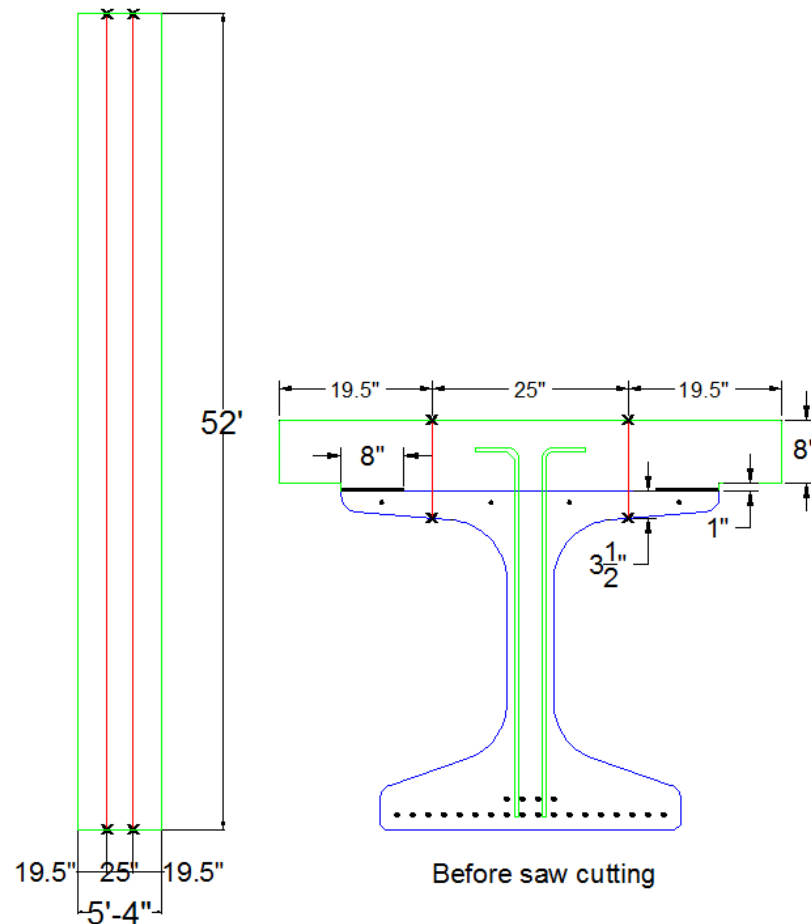

FIGURE 6-9: LOCATION OF LONGITUDENAL SAW CUTS ON GIRDER #2

The 12 in deep longitudinal cut required four passes, cutting down about 3 in. per pass. In the last pass, a larger blade was required. The blade was switched from an 18 in. diameter blade to a 24 in. diameter blade as shown in Figure 6-10. Saw cutting was most difficult when the blade hit a longitudinal bar, because the bar would be needed to be cut in the longitudinal direction, which slowed down the process. Figure 6-11 shows a cross-sectional view of the cut flange girder after saw cutting was completed. The total time required was five hours to finish the saw cutting on both girders. Two hours were spent on the full flange girder, and three hours on the cut flange girder.



FIGURE 6-10: SEPERATION OF DECK AND FLANGE AFTER FALLING DOWN



FIGURE 6-11: FINISHED SAW CUTS FOR CUT FLANGE GIRDER

### 6.1.2 JACK HAMMERING SEQUENCE

The next step is to remove the deck above the girder and around the shear connectors by jack hammering. The jack hammering plan for both girders is to have deck completely removed in half of the girder (100% deck removal), and partially removed around the connectors in the other half (50% deck removal). The purpose of doing this, is to investigate the effect of deck removal level on horizontal shear capacity. By not requiring the contractor to completely remove the old deck around the connectors, significant savings in the removal cost and duration could be achieved.

There is no specific volume or dimensions of the concrete deck to leave around the connector; jack hammering is not a very precise action and this would defeat the purpose. However, it is important to leave some space, about 1-2 in. underneath each stirrup leg. This would provide the space for the new deck to latch onto the bar as well as the necessary clearance. Also, enough space in-between the shear connectors should be provided to lay transverse reinforcement of the new deck. Three workers from a local concrete removal contractor were hired to do this job. Observations were made, activity logs were recorded, and different removal methods were attempted.

Figure 6-12 and Figure 6-13 shows a plan view, cross-sectional view, and side view of the jack hammering plan with the orange hatched area being the area to jack hammer. The remaining deck after saw cutting on the full flange girder is a 2 ft – 8 in. wide, 9 in. deep, and 52 ft long deck. And the remaining deck for the cut flange girder is 25 in. wide, 9 in. deep, and 52 ft long. The job took five days to complete, with the fifth day being a half day.

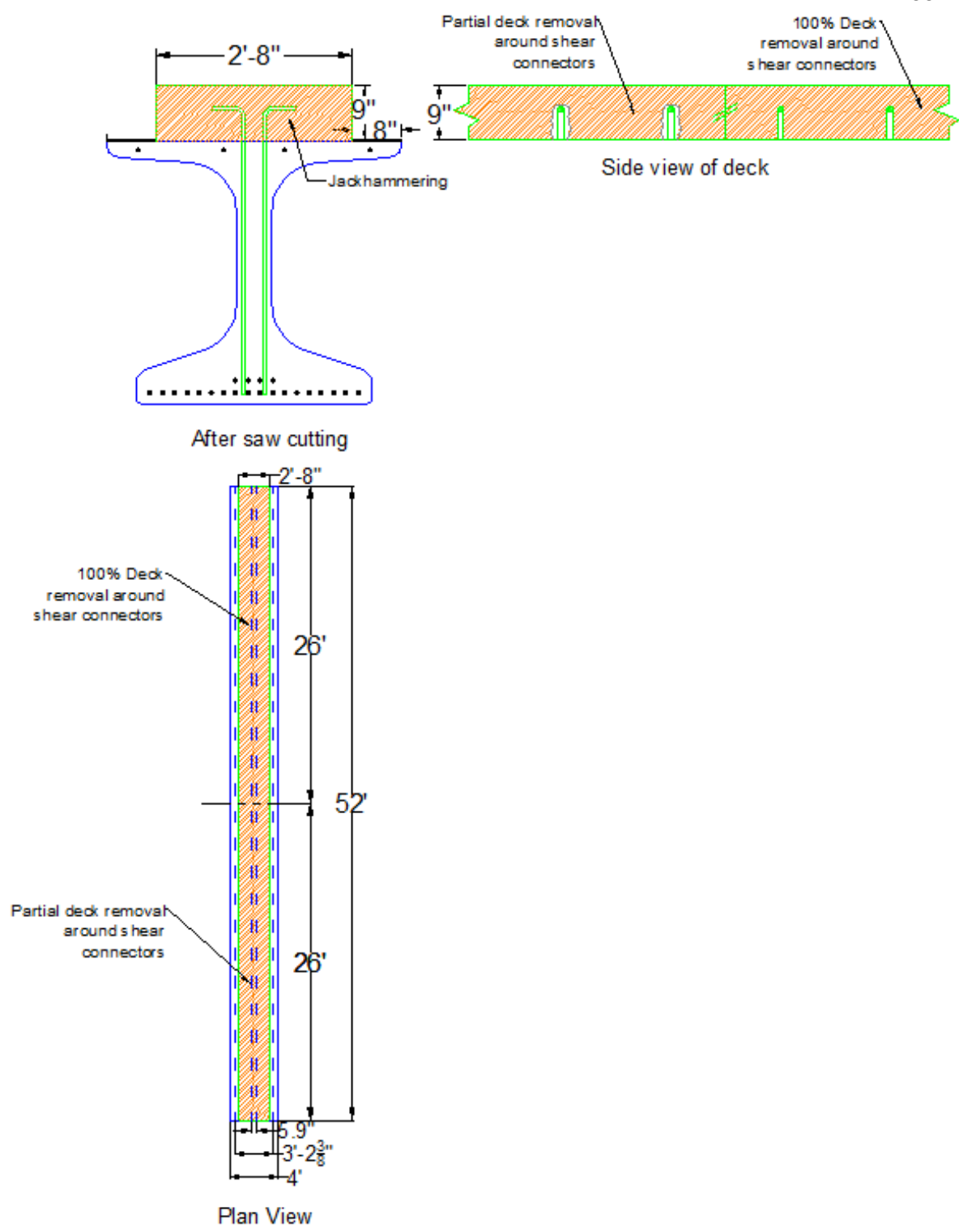

FIGURE 6-12: JACK HAMMERING PLAN FOR GIRDER #1

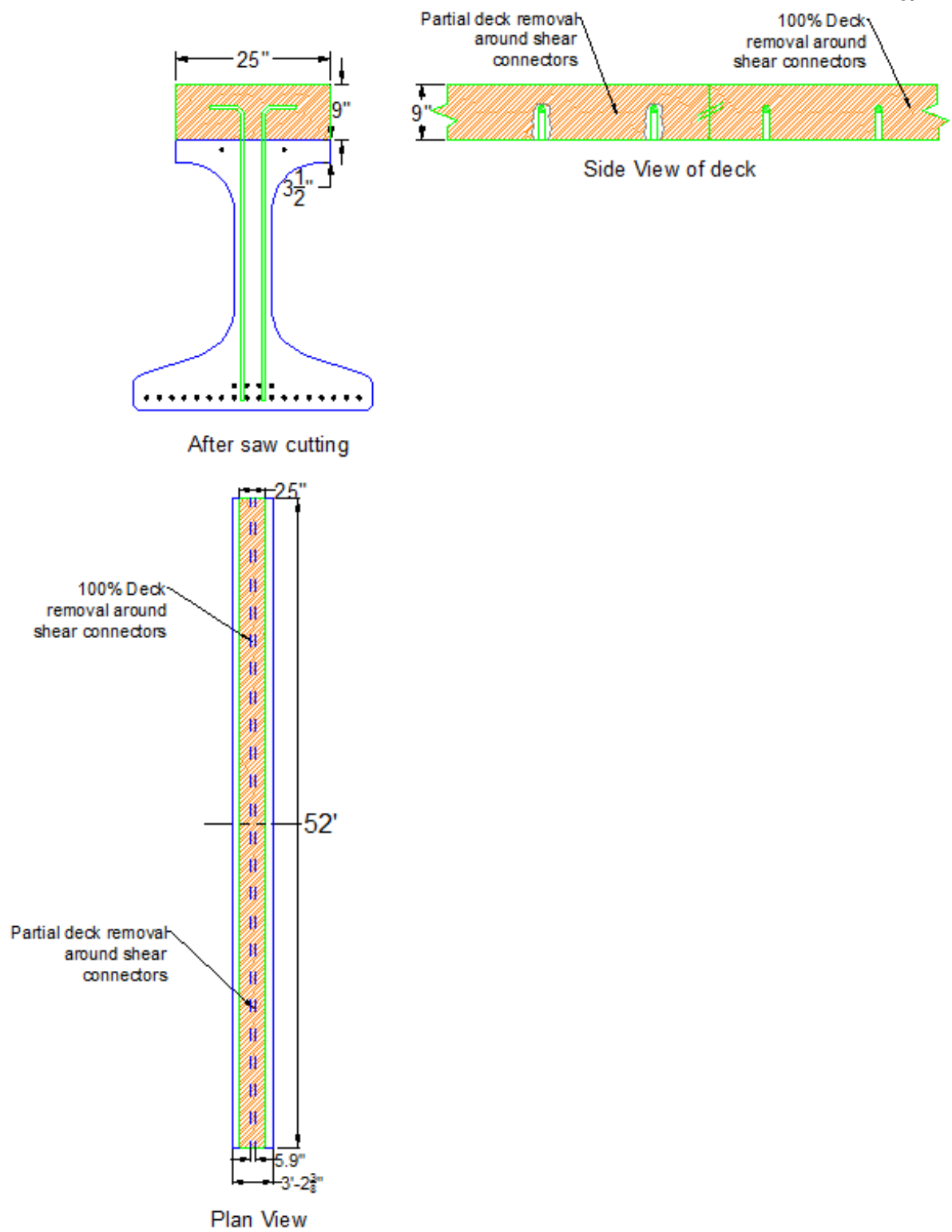

FIGURE 6-13: JACK HAMMERING PLAN FOR GIRDER #2

Two sizes of jack hammers were used. The 90 lb jack hammer was used down to the depth of shear connectors. This top 4 in. of concrete took the least time per unit volume to remove. Once the shear connectors reached, the 60 lb jack hammer was used to remove the remaining concrete, which was much more difficult especially at the girder ends where the spacing between shear connectors is small as shown in Figure 6-14.



FIGURE 6-14: DIFFICULT REMOVING CONCRETE UNDER LONGITUDENAL BARS

For the full flange girder, approximately 88 ft<sup>3</sup> total volume of concrete deck needed to be removed. For the cut flange girder, approximately 62 ft<sup>3</sup> needed to be removed. At the end of the first day, workers removed approximately 51 ft<sup>3</sup> of concrete. This was mostly the volume of concrete above the stirrups, shown in Figure 6-15, which is the easiest to remove.





FIGURE 6-15: JACK HAMMERING DOWN TO STIRRUPS

Using the 90 lb jack hammer caused vibration that resulted in minor damages to the sides of the top flange as shown in Figure 6-16. Stirrups were also damaged from the blunt force of the 90 lb jack hammer (Figure 6-17). Few instances caused delays in jack hammering, such as the generator shutting off, and the jack hammer getting stuck.



FIGURE 6-16: DAMAGED FLANGE FROM VIBRATION OF 90LB JACK HAMMER



FIGURE 6-17: DAMAGED STIRRUP LEGS

At the end of the second day, the crew suggested to saw cut the deck transversely to speed up the deck removal with the jack hammer. A hand held saw is used. Transverse saw cuts were made every 5 in. for about a 4 in. depth, seen in Figure 6-18 and Figure 6-19. This method is much more efficient. The concrete came out easier in bigger chunks. It was especially efficient with simultaneous jack hammering and use of electric hand chipper. Jack hammers were used vertically from the top of the deck, while electric chipper was used from the side. The concrete came out in larger blocks. At the end of the second day, approximately an additional 46 ft<sup>3</sup> of concrete had been removed. At the end of the third day, the “fully removed” half of the cut flange girder was completed, leaving only the “partially removed” half. This is approximately 26ft<sup>3</sup> of concrete. The

full flange girder had only the concrete around the stirrups for the full length of the girder.



FIGURE 6-18: TRANSVERSE SAW CUTTING EVERY 5 IN.



FIGURE 6-19: DEPTH OF SAW CUTS ABOUT 4 IN.; 1 IN. FROM TOP FLANGE

Deck removal continued with the technique of first transverse saw cutting, then jack hammering and chipping. It was specified to leave space underneath the stirrup legs, about 1-2 in. Figure 6-20 and Figure 6-21 show simultaneous jack hammering and electric chipping while keeping the necessary clearance underneath stirrup legs. At the end of the fourth day, the jack hammering plan was completed on the full flange girder.

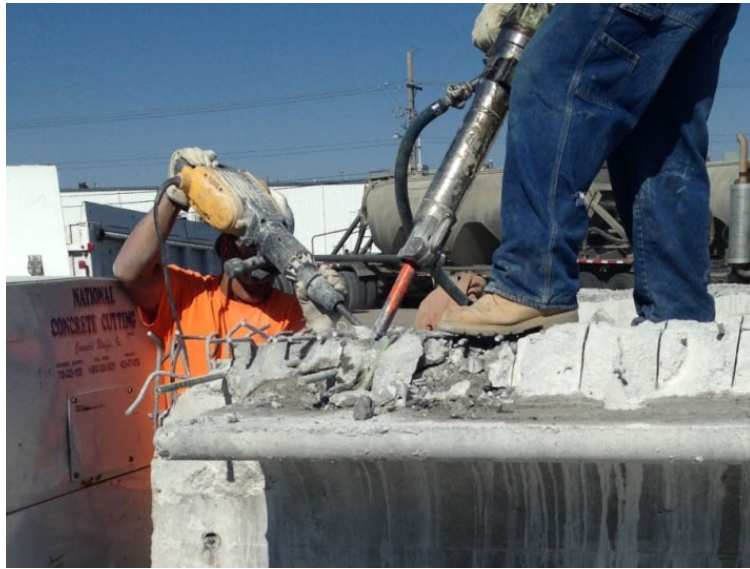

FIGURE 6-20: LEAVING SPACE UNDERNEATH STIRRUP LEGS, AND REMOVING TRANSVERSE BARS ON FULL FLANGE GIRDER



FIGURE 6-21: 1-2 IN. OF SPACE UNDERNEATH STIRRUP LEGS

On the fifth day, the jack hammering job was completed on the cut flange girder. There was damage observed on the top flange of the girder, which can be seen in Figure 6-22. Also, some damage to the stirrups, one which completely detached from the flange (Figure 6-23). The total time to finish the last portion of the job, about 25 ft<sup>3</sup> of concrete, took 3.5 hrs. A view of the prepared NU1100 specimen after saw cutting and jack hammering procedures is seen in Figure 6-24.



FIGURE 6-22: DAMAGED FLANGE ON GIRDER #2



FIGURE 6-23: BROKEN STIRRUP LEG



FIGURE 6-24: JOB COMPLETED ON OCT 26<sup>TH</sup> BY NOON

A man-hour log was made for the full flange girder and cut flange girder. The results show that by spending 1 extra hour on saw cutting through the top flange, it will save approximately 20% of the jack hammering on top of the girder ( Table 6-1).

TABLE 6-1: SUMMARY OF MAN-HOUR LOG

| Time spent of Manual Labor |                    |                   |
|----------------------------|--------------------|-------------------|
|                            | Full Flange Girder | Cut Flange Girder |
| Saw Cutting                | 2 hours            | 3 hours           |
| Jack Hammering             | 60 hours           | 48 hours          |
| Total MHrs                 | <b>62 hours</b>    | <b>51 hours</b>   |

## 6.2 SPECIMEN TESTING

The two NU1100 girders were shipped to the structural laboratory at Peter Kiewit Institute in Omaha, NE on November 20<sup>th</sup>, 2013. Since there are no lifting points, girders

were handled by wrapping lifting chains around the girders and to place them on the supports for flexure testing.

### 6.2.1 RE-DECKING

For the full flange girder, a 4 ft wide and 7.5 in. thick deck was formed using plywood sheets and threaded rod ties as shown in Figure 6-25 and Figure 6-27. The new deck was reinforced transversely in two layers with #5@12 in. and longitudinally with 4#8 at the mid-thickness, which is equivalent to two layers of #4@12 in. over 8 ft wide deck.



FIGURE 6-25: TIES WITH PVC PIPE SPACED 3FT APART TO HOLD FORM SIDES

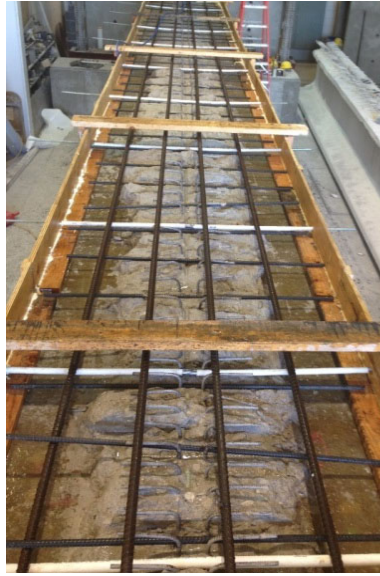

FIGURE 6-26: TOP VIEW OF REINFORCEMENT

The deck was poured using 8 ksi self-consolidating concrete (SCC) with 25 in. slump. This is equivalent to a 4 ksi concrete for 8 ft wide deck. Figure 6-27 shows the new deck after forms have been stripped.

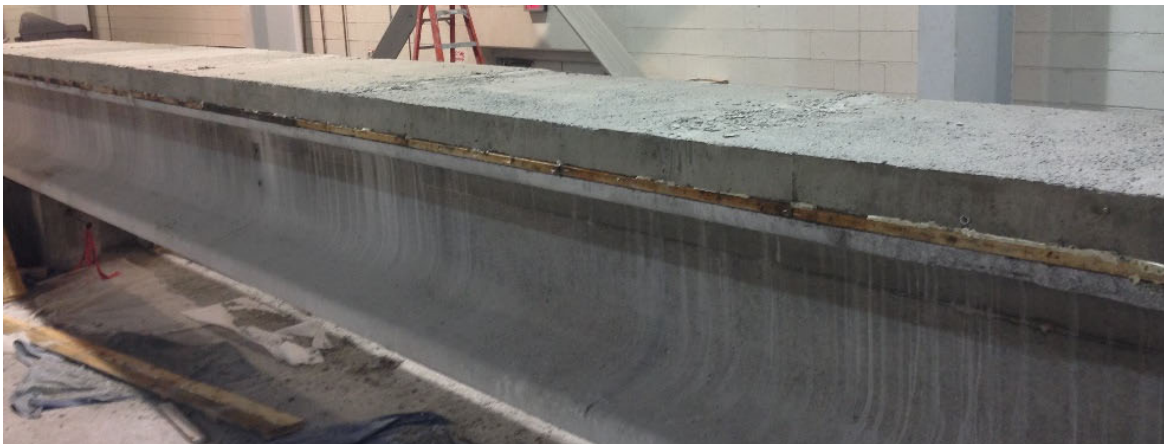

FIGURE 6-27: VIEW OF FULLY COMPOSITE DECK FOR FULL FLANGE GIRDER

The same procedures were followed for re-decking the cut flange girder. It should be noted that two pairs of shear connectors on each half of the girder was cut off from the flange on both the fully removed and partially removed halves as shown in Figure 6-29.



This was suggested to simulate the situation when some shear connectors are damaged during the jack hammering process.



FIGURE 6-28: CUT SHEAR CONNECTORS IN PARTIALLY REMOVED SECTION

### 6.2.2 TEST SETUP

Girders were tested in flexure after the desired concrete compressive strength was achieved. The test setup is shown in Figure 6-29. Girders were simply supported on concrete blocks and roller supports that are spaced 40 ft on center. Two threaded rods that are 10 ft apart were used to anchor the steel loading I-beam to the strong floor. A 400 kip capacity hydraulic jack and load cell were used for loading each girder at mid-span. Rotation of the loading frame was prevented by using a strap on both sides; straps were anchored into the ground 12 ft from the center of the girder on either side as shown in Figure 6-30

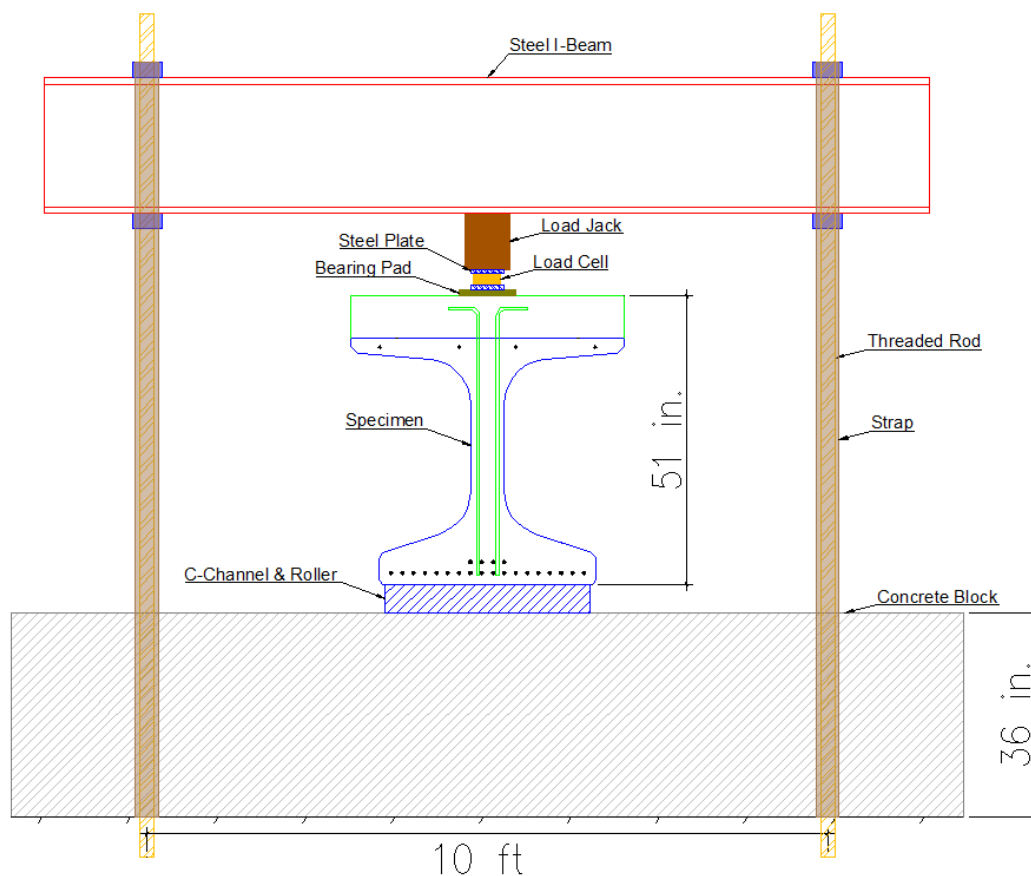

FIGURE 6-29: CROSS SECTIONAL VIEW OF TEST SETUP (FULL FLANGE GIRDER EXAMPLE)

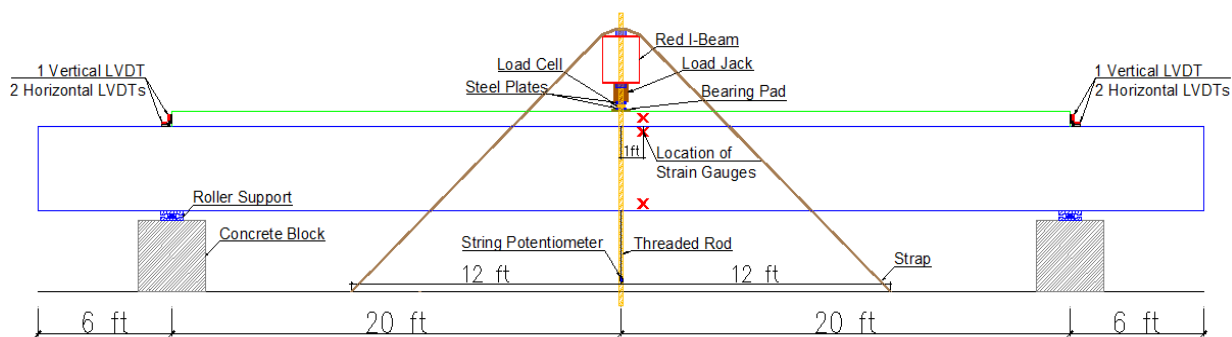

FIGURE 6-30: ELEVATION VIEW OF TEST SETUP AND SPAN LENGTHS

Each girder was instrumented with four horizontal and two vertical linear variable differential transformers (LVDT's) to measure displacement, one string potentiometer to measure deflection at mid-span, and three strain gauges to measure strains at the critical

section. Figure 6-31 show the instrumentations used during testing. A view of the completed test setup on the full flange girder is shown in Figure 6-32.



FIGURE 6-31: LVDT'S (LEFT), STRAIN GAUGES (RIGHT)



FIGURE 6-32: TEST SETUP ON FULL FLANGE GIRDER

## *6.3 ANALYSIS OF RESULTS*

### 6.3.1 CONCRETE COMPRESSIVE STRENGTH

The compressive strength testing results of the cores extracted from the girders and the cylinders made from the newly poured deck are shown in Table 6-2. These results indicate that the measured strength exceeded the specified strength significantly for the new deck.

TABLE 6-2: CONCRETE COMPRESSIVE STRENGTH RESULTS

| Cylinder   | Full Flange Deck<br>poured on Nov 27th |                    | Cut Flange Deck<br>poured on Dec 19th |                    | Camp Creek Girder<br>cored cylinders |
|------------|----------------------------------------|--------------------|---------------------------------------|--------------------|--------------------------------------|
|            | 4-day<br>strength                      | 16-day<br>strength | 7-day<br>strength                     | 18-day<br>strength | Strength recorded<br>on 12/12/2013   |
| 1          | 8,897                                  | 10,765             | 9,679                                 | 11,052             | 6,994                                |
| 2          | 8,885                                  | 11,093             | 10,052                                | 11,911             | 7,236                                |
| 3          | 8,903                                  | 11,209             | 9,234                                 | 11,259             | -                                    |
| Ave. (psi) | 8,895                                  | 11,022             | 9,655                                 | 11,407             | 7,115                                |

### 6.3.2 FULL FLANGE GIRDER TEST

The full flange girder was tested on December 10<sup>th</sup>, 2013. Horizontal and vertical LVDTs will be referred to as H-NW and H-NE for the horizontal North West and North East LVDTs; and as V-N and V-S for the vertical north and south LVDTs. Strain gauges were labeled as deck, top flange, and bottom flange strain gauges. The same notations were used for the cut flange girder. The full flange girder failed in flexure at an ultimate load of 379 kips and had a cracking load of 224 kips. The vertical deflection at mid-span was 0.45 in. at the cracking load and 5.83 in. at ultimate load. Flexural failure mode is shown in Figure 6-33.



FIGURE 6-33: FAILURE MODE OF FULL FLANGE GIRDER

The load-deflection curve of testing the full flange girder is shown in Figure 6-34. This figure indicates the elastic behavior of the composite girder up to the cracking load; and the leveling off of the curve up to the ultimate load.

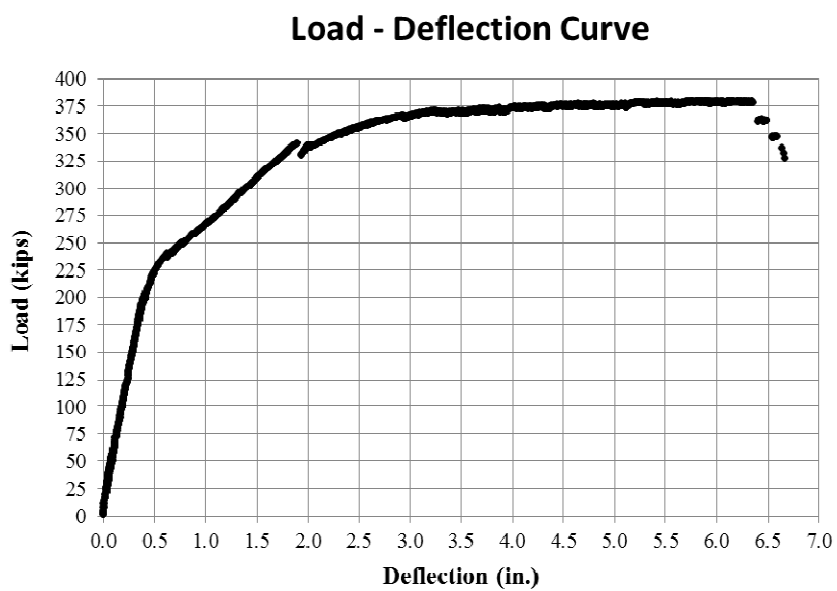

FIGURE 6-34: FULL FLANGE - LOAD VS. DEFLECTION GRAPH

Figure 6-356 plots strain data at the critical section. This plot indicates the increase in the compression strains at the top fibers and tension strains at the bottom fibers up to failure load, which demonstrates the composite action of the girder.

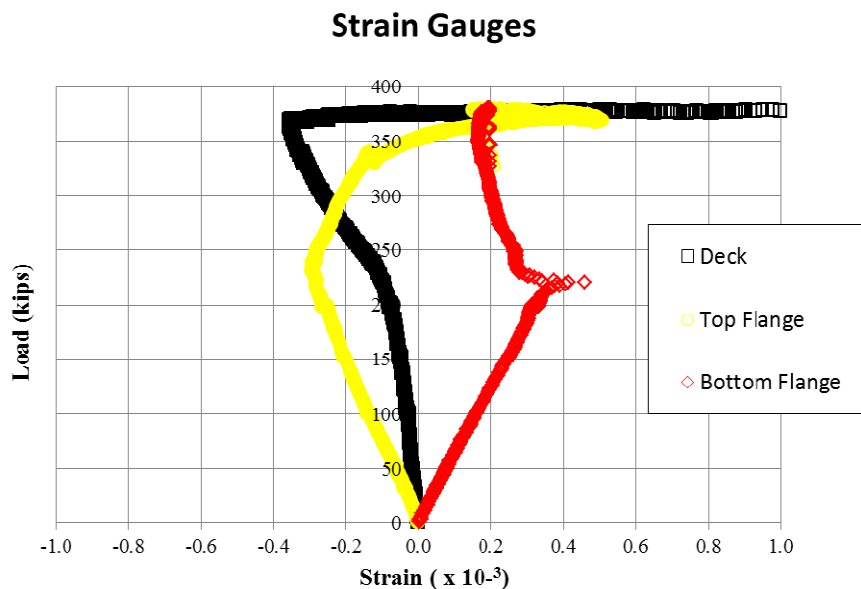

FIGURE 6-35: FULL FLANGE - LOAD VS. STRAIN GRAPH

The relative displacement data gathered from LVDTs is shown in Figure 6-36 and Figure 6-37. These two graphs indicate that horizontal and vertical displacements of the new deck relative to the girder are negligible as the maximum value for horizontal displacement is 0.001 in. and for vertical displacement is 0.0035 in., which are less than 0.01 in. (minimum acceptable initial slip). Furthermore, the displacements of the fully removed half of the girder and the partially removed half are identical. This indicates that the level of deck removal around the shear connectors does not affect the horizontal shear capacity of the full flange girder.

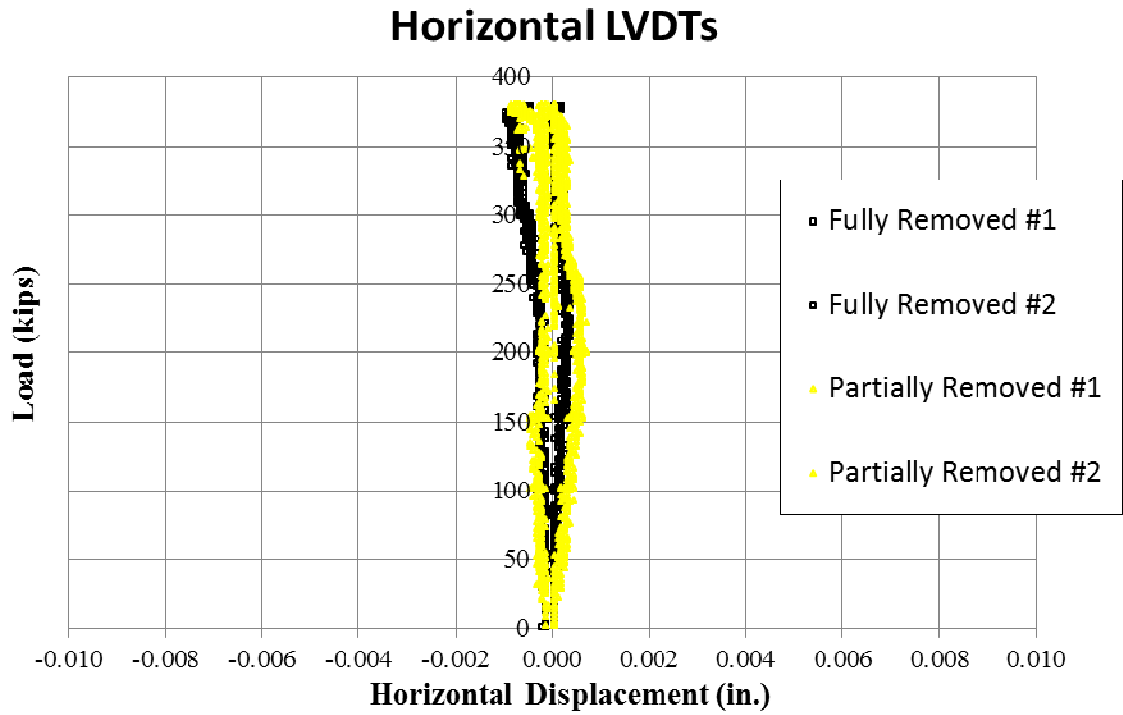

FIGURE 6-36: HORIZONTAL DISPLACEMENT FOR PARTIALLY REMOVED VS. FULLY REMOVED

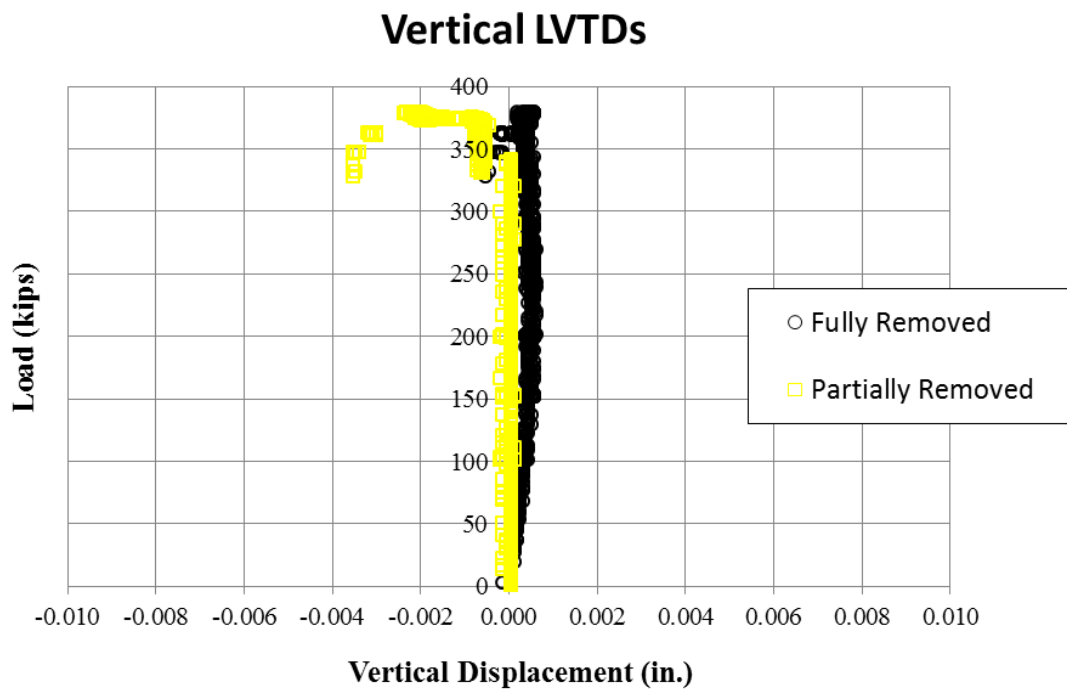

FIGURE 6-37: VERTICAL DISPLACEMENT FOR PARTIALLY REMOVED VS. FULLY REMOVED

### 6.3.3 CUT FLANGE GIRDER TEST

The cut flange girder was tested on January 9<sup>th</sup>, 2014. The girder failed in flexure; however the strands did not rupture as shown in Figure 6-38. The ultimate load was 378 kips and the cracking load was 230 kips. The vertical deflection at mid-span was 0.35 in. at the cracking load and 5.96 in. at ultimate load as shown in the load-displacement curve plotted in Figure 6-39. Figure 6-3541 plots strain data at the critical section. This plot indicates the increase in the compression strains at the top fibers and tension strains at the bottom fibers up to failure load, which demonstrates the composite action of the girder.



FIGURE 6-38: CUT FLANGE GIRDER FAILURE MODE



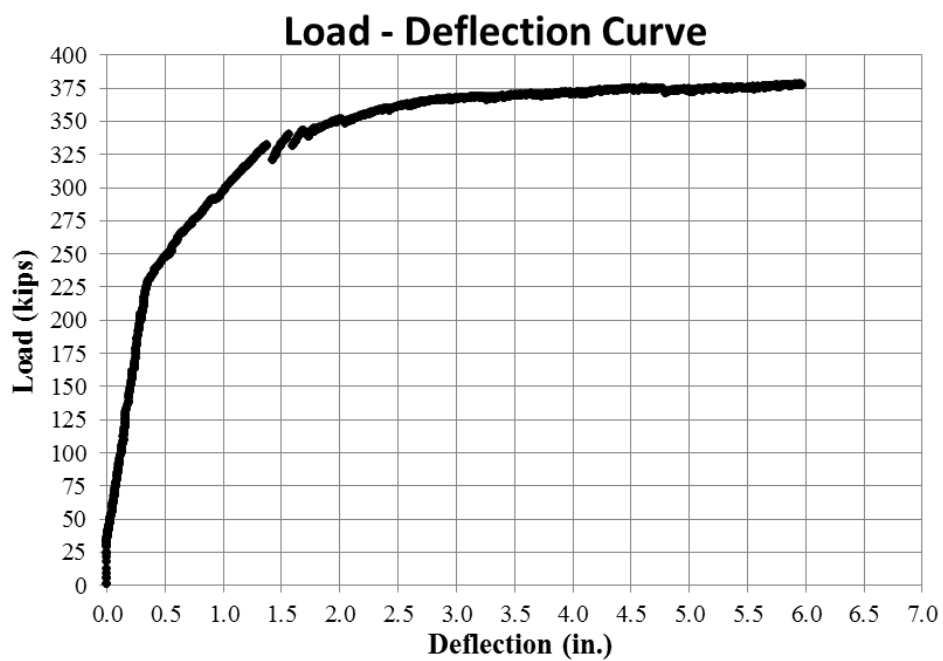

FIGURE 6-39: CUT FLANGE - LOAD VS. DEFLECTION GRAPH

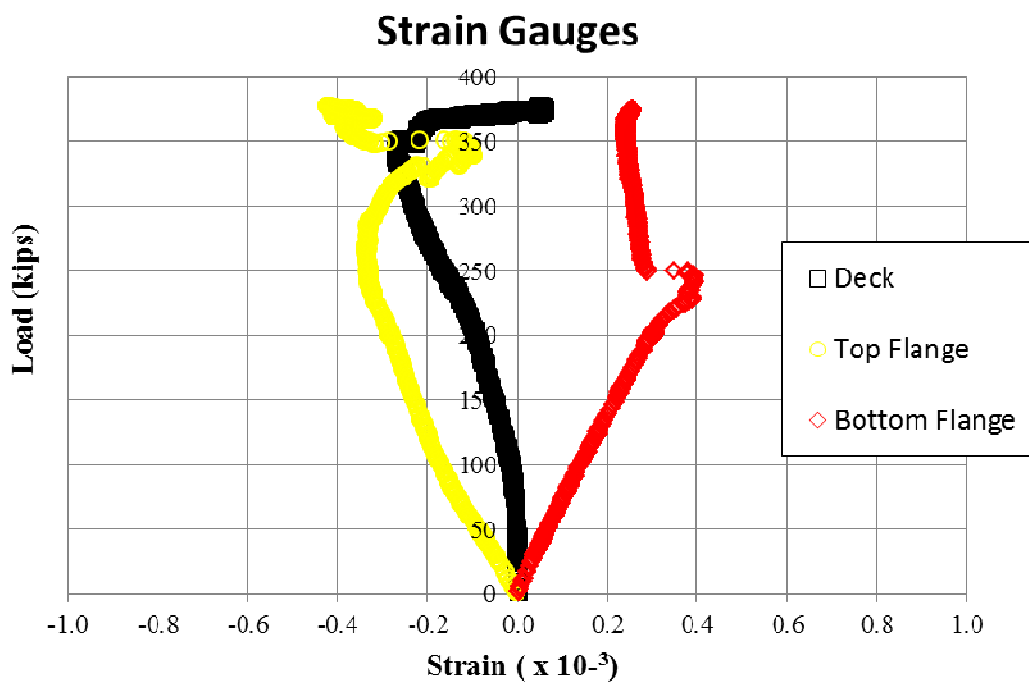

FIGURE 6-40: CUT FLANGE - LOAD VS. STRAIN GRAPH

Figure 6-41 and Figure 6-42 show the horizontal and vertical displacements of the new deck relative to the girder. The amount of displacements was negligible as the maximum value is 0.002 in., which is lower than the minimum acceptable value for initial slip (0.01 in.). Furthermore, the displacements of the fully removed half of the girder and the partially removed half are identical. This indicates that the level of deck removal around the shear connectors does not affect the horizontal shear capacity of the cut flange girder.

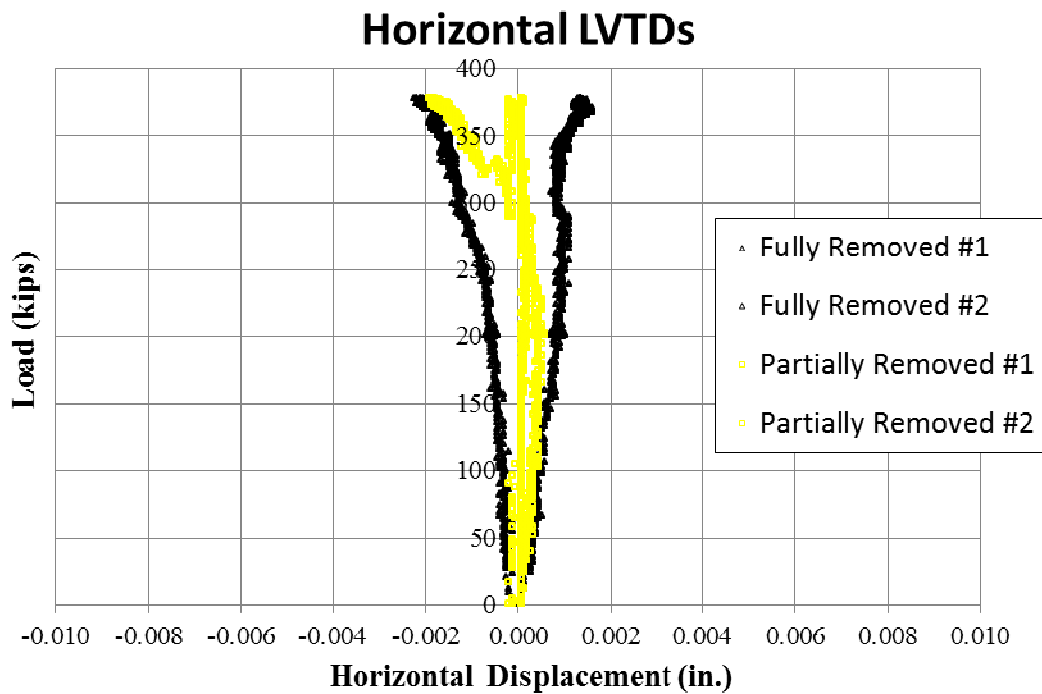

FIGURE 6-41: HORIZONTAL DISPLACEMENT FOR PARTIALLY REMOVED VS. FULLY REMOVED

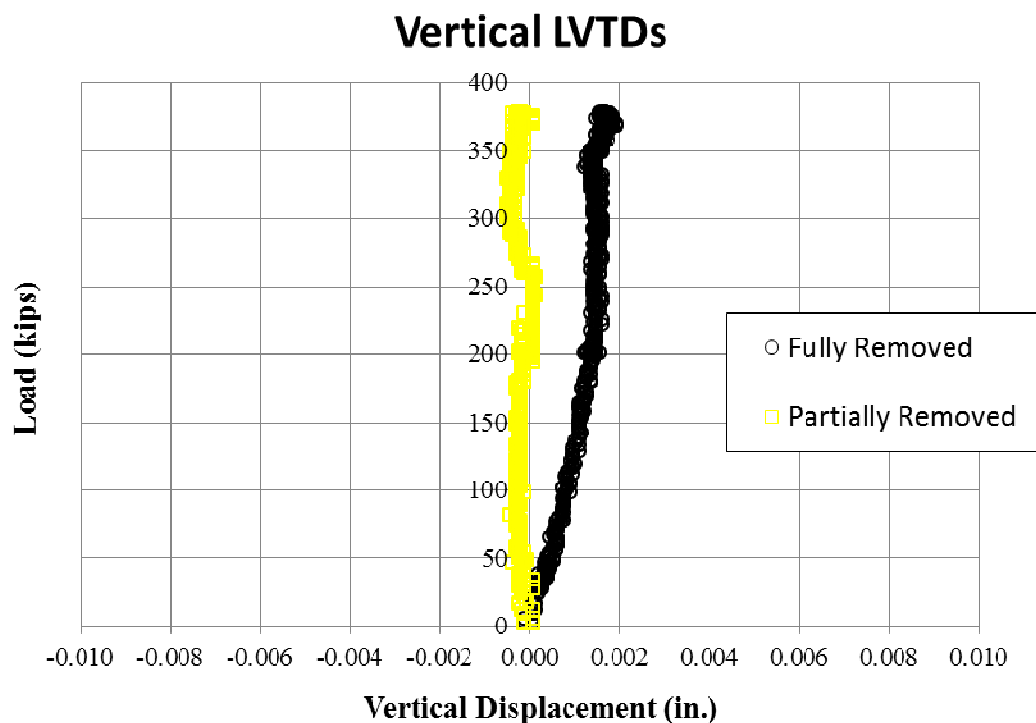

FIGURE 6-42: VERTICAL DISPLACEMENT FOR PARTIALLY REMOVED VS. FULLY REMOVED

### 6.3.4 COMPARISON

Comparing the test results of the full flange girder and cut flange girder indicates that the top flange width has no effect on the flexural capacity, which confirms the results of the analytical investigation presented in chapter 4. Figure 6-43 shows the load-deflection curves of the two girders, while Figure 6.45 and Figure 6.46 plot the measured cracking load, ultimate load, and deflection versus predicted ones. This plot indicates that measured values are very close to the predicted values, calculated assuming fully composite section. This means that tested girders whether full flange, cut flange, with partial deck removal, or with full deck removal behaved as fully composite with the new deck.

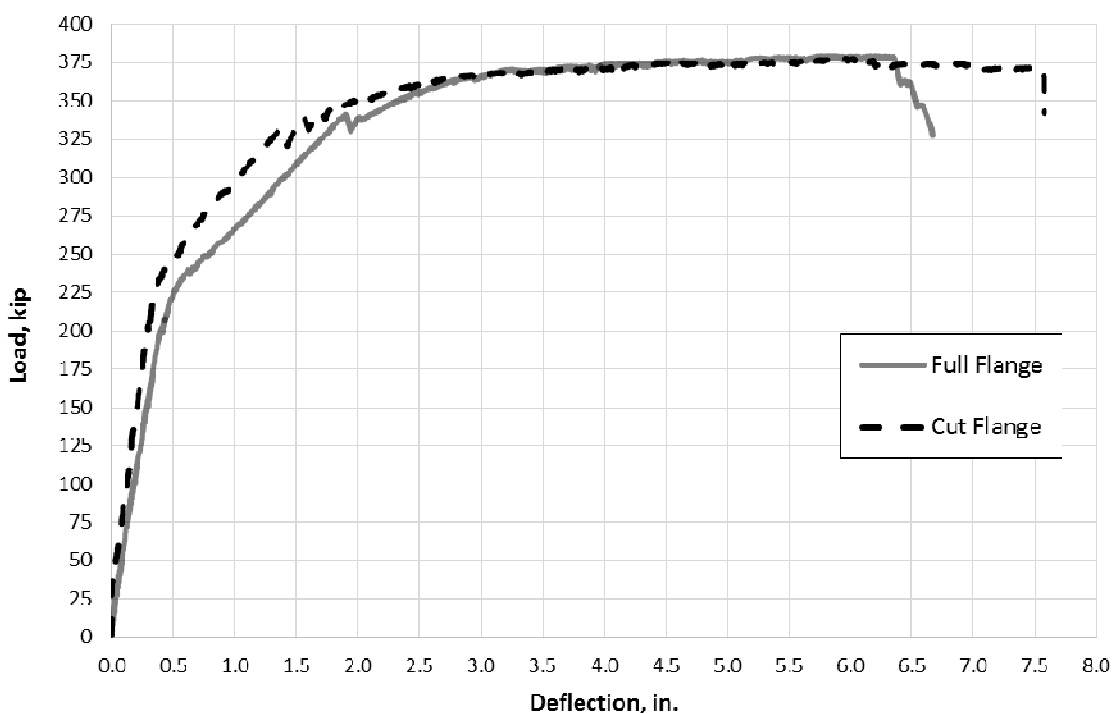

FIGURE 6-43: LOAD VS. DEFLECTION CURVE OF INVESTIGATED NU1100 GIRDERS

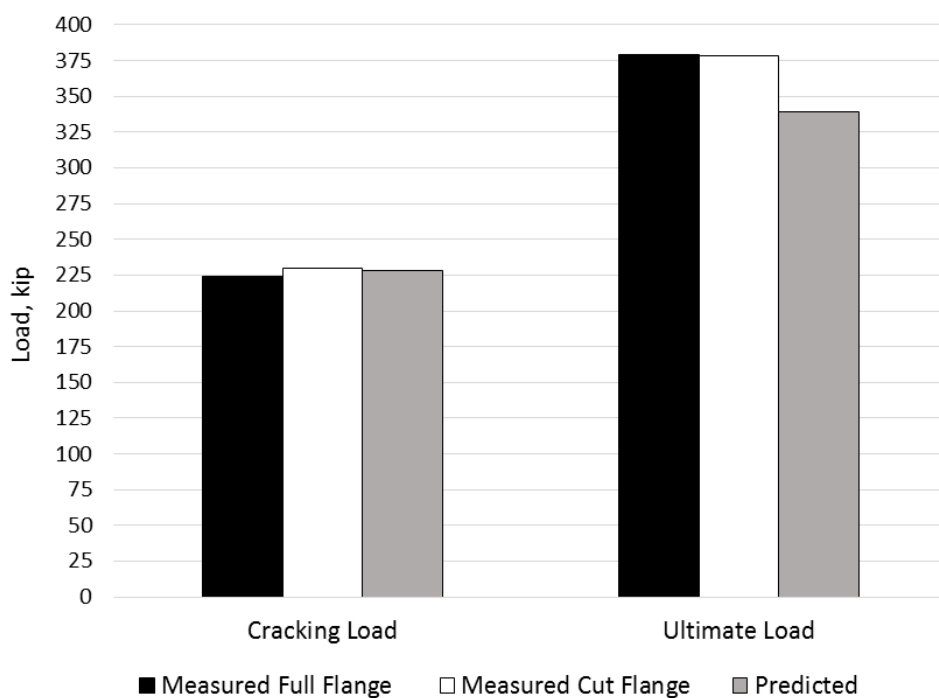

FIGURE 6-44: BAR GRAPH COMPARING ACTUAL TO PREDICTED LOAD

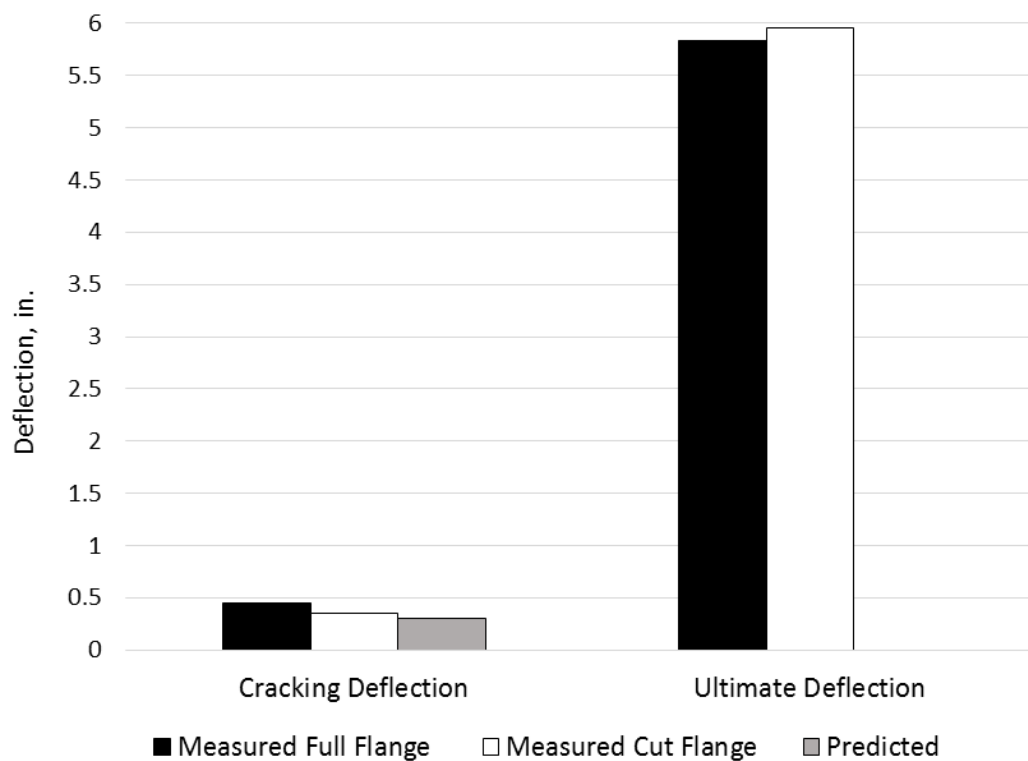

FIGURE 6-45: BAR GRAPH COMPARING ACTUAL TO PREDICTED DEFLECTION

## 7. CONCLUSIONS

Based on the results of the field investigations, analytical investigation, and experimental investigation presented in this thesis, the following conclusions can be made:

1. Saw cutting, jack hammering, and hydro demolition are the most common methods of deck removal for re-decking.
2. Debonding the edges of the top flange is an effective way for lifting saw cut deck panels between girders without damaging the thin top flange of the girders.

3. The most cost effective method of deck removal is highly dependent on the quantity, environmental restrictions, and type of girder and its shear connectors.
4. Leaving approximately 50% of the old deck concrete around shear connectors does not significantly affect the horizontal shear capacity of the new composite section.
5. The effect of cutting approximately 50% of the girder top flange width on the structural performance of the girder is highly dependent on the span-to-depth ratio. In girders with low span-to depth ratio, this effect is negligible; however, in girders with high span-to-depth ratio, this effect could be significant. Flexural capacity, horizontal shear capacity, and deflections should be checked during construction and at final stages.

## 8. RECOMMENDATIONS

Based on the observations made in this project and the outcomes of the literature search and analytical and experimental investigations, the following recommendations can be made:

1. Extend the width of the debonded strip for wide and thin top flange girders, such as NU girders, to be at least 12 in. instead of 8 in. as shown in Figure 8-1. This will minimize the amount of deck that needs to be jackhammered, which is a tedious and costly process, and ensure easy lifting of deck panels.
2. Saw cut deck panels at angles to simplify the deck removal process rather than using vertical saw cuts as shown in Figure 8-1. However, pivoted saw cut machines are needed to improve the efficiency of this option compared to using the frame mounted saws that slow down the process.

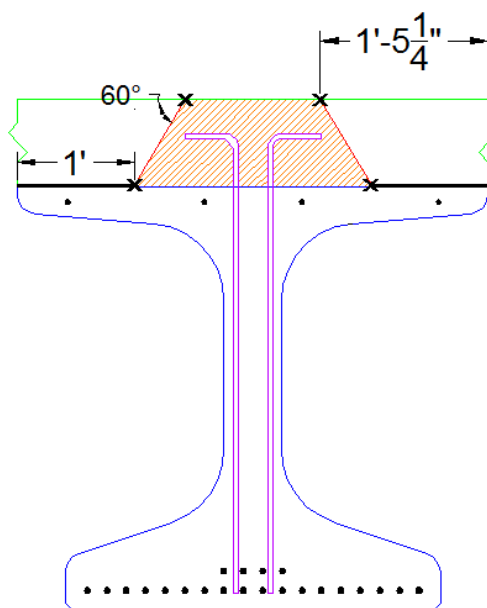

FIGURE 8-1: RECOMMENDED PRACTICE FOR DEBONDING AND SAW CUTTING

3. For existing bridges with low span-to-depth ratio and narrow debonded zone, saw cut the deck outside the shear connectors and through the wide and thin girder top flange as shown in Figure 8-2. The remaining concrete around the shear connectors could be manually removed with 60 lb jack hammers up to the level of the shear connectors, and 30 lb jack hammer below the shear connectors.

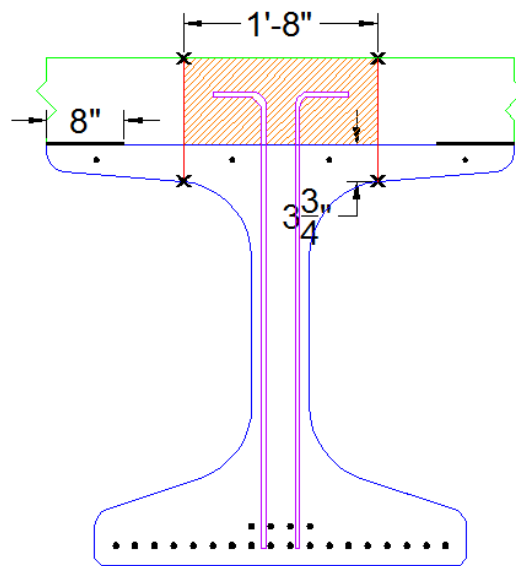

FIGURE 8-2: RECOMMENDED PRACTICE FOR EXISTING BRIDGES

4. Approximately 50% of the concrete around the shear connectors can be left unremoved as long as the concrete is not contaminated and will not affect the durability of the new deck. Also, several transverse cuts are recommended to maximize the efficiency of deck removal over the girder flange.



## WORKS CITED

AASHTO. (2007). *AASHTO LRFD Bridge Design Specifications: Customary U.S. Units: 2008 Interim Revisions* (4th ed.). Washington, D.C.

Alberta Ministry of Transportation. (2010). *Specifications for Bridge Construction*. Alberta, Canada: Alberta Ministry of Transportation.

Hydro-Technologies, I. (2012). *hydrodemolition* | *Hydro-Technologies*. Retrieved 10 31, 2012, from <http://www.hydro-technologies.com/>

Spenser, E. R. (2010). *RSMMeans Heavy Construction Cost Data*. Kingston, MA.

Tadros, M. K., & Baishya, M. C. (1998). *NCHRP Report 407: Rapid Replacement of Bridge Decks*. Washington, DC: National Academies Press.