

University of Nebraska - Lincoln

DigitalCommons@University of Nebraska - Lincoln

Proceedings of the 7th Vertebrate Pest
Conference (1976)

Vertebrate Pest Conference Proceedings
collection

March 1976

AVOIDANCE OF PREY BY CAPTIVE COYOTES PUNISHED WITH ELECTRIC SHOCK

Samuel B. Linhart

U.S. Fish and Wildlife Service, Wildlife Research Center, Denver, Colorado

Jerry D. Roberts

U.S. Fish and Wildlife Service, Wildlife Research Center, Denver, Colorado

Stephen A. Schumake

U.S. Fish and Wildlife Service, Wildlife Research Center, Denver, Colorado

Richard Johnson

U.S. Fish and Wildlife Service, Wildlife Research Center, Denver, Colorado

Follow this and additional works at: <https://digitalcommons.unl.edu/vpc7>



Part of the [Environmental Health and Protection Commons](#)

Linhart, Samuel B.; Roberts, Jerry D.; Schumake, Stephen A.; and Johnson, Richard , "AVOIDANCE OF PREY BY CAPTIVE COYOTES PUNISHED WITH ELECTRIC SHOCK" (1976). *Proceedings of the 7th Vertebrate Pest Conference (1976)*. 30.

<https://digitalcommons.unl.edu/vpc7/30>

This Article is brought to you for free and open access by the Vertebrate Pest Conference Proceedings collection at DigitalCommons@University of Nebraska - Lincoln. It has been accepted for inclusion in Proceedings of the 7th Vertebrate Pest Conference (1976) by an authorized administrator of DigitalCommons@University of Nebraska - Lincoln.

AVOIDANCE OF PREY BY CAPTIVE COYOTES PUNISHED WITH ELECTRIC SHOCK

SAMUEL B. LINHART, JERRY D. ROBERTS, STEPHEN A. SHUMAKE, and RICHARD JOHNSON, U.S. Fish and Wildlife Service, Wildlife Research Center, Denver, Colorado 80225

ABSTRACT: Four individually penned coyotes (Canis latrans) that had learned to kill live domestic rabbits for food were presented with one black and one white rabbit during daily 1-hour sessions and punished by a brief, severe shock from a high-voltage collar each time they attacked the black rabbit. One coyote did not learn the color association; after three shocks, it refused to kill either rabbit for 10 days but killed both indiscriminately when retested 4 weeks later. The other three coyotes learned to avoid black rabbits after only three to five shocks and, when repeatedly retested without shock at several-week intervals, did not begin killing them again until 3 to 9 months later. These animals' rapid acquisition and long retention of an avoidance response to a certain class of prey suggests a potential for aversive stimuli to reduce coyote attacks on livestock.

Coyote predation on domestic sheep has been a problem ever since livestock were first introduced into the western United States. When operational use of toxicants to control coyotes was banned by a Presidential Executive Order in 1972, research efforts were turned to developing nonlethal methods of reducing coyote predation, including aversive stimuli that could be placed on or near sheep exposed to attack. Tests in pens to evaluate coyote learning and retention capabilities, while admittedly conducted under highly confined conditions, should aid in determining the potential of such aversive stimuli as a means of modifying coyotes' predatory behavior.

This study was undertaken to determine the speed and duration with which captive coyotes (Canis latrans) learn to passively avoid attacking a certain class of prey (black domestic rabbits) following pairing with a noxious stimulus (electric shock). Although aversive conditioning of dogs by electric shock has been investigated by Kellogg and Wolf (1939), Brogden (1949), Solomon, Kamin, and Wynne (1953), and Solomon and Wynne (1953, 1954), no such studies have been reported for the coyote.

METHODS

Animals

Four adult coyotes (two females, two males), captured as young pups or born in captivity, were maintained in separate pens throughout the study. Water was always available. On days that coyotes were given rabbits, they received no other food; at all other times they were fed their standard diet of commercial dry dog food ad libitum. Solid-colored juvenile domestic rabbits weighing 0.5-0.7 kg were used as the prey species. Black rabbits were selected as the "negative" prey and white rabbits as the "positive" prey.

Facilities

The sides of the concrete-floored, chain-link, 2 x 2 x 4 m pens were covered with sheet metal about 1 m high to reduce outside visual disturbance. A wooden shelter box was attached at the back end of each pen. The forward half of each cage was partitioned by a plywood barrier about 1 m high and 2 m long running from the center of the front wall to the center of the pen.

Electric Shock Device

An electric shock was administered by a high-voltage collar that consisted of three parts (Fig. 1): a small 27-MHz receiver modulated at 400 Hz (Saturn model, Royal Electronics Corp.,* Denver, Colo.), a heavy-duty relay, and the high-voltage unit from an electric livestock prod (Hotshot Prod Co., Inc., Savage, Minn.). The receiver was powered by two paralleled mercury batteries (Mallory T.R. 132R, 2.7 V) which provided a continuous life of about 7 days. Power for the high-voltage unit was supplied by one nickel-cadmium

*Reference to trade names does not imply U.S. Government endorsement of commercial products.

battery (Gulton, 8 V, 500 MAH), which was selected for its high current drain capability. The open circuit voltage from the collar was at least 7000 V when the battery had a full charge; the output could be changed, if desired, by selecting a different supply voltage. The collar was manually activated by a 27-MHz transmitter, also modulated at 400 cycles. The tone modulation was necessary so that shocks would be delivered only in response to our transmitter.

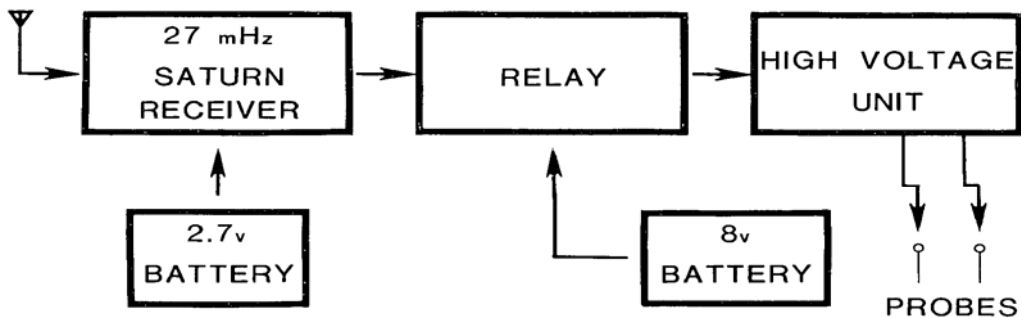

Figure 1. Block diagram of high-voltage collar.

Procedure

During daily 1-hour sessions, each coyote was simultaneously presented with a black rabbit and a white rabbit tethered with a short length of cord to the front of the pen on either side of the wooden partition. The position of the rabbits was randomly alternated daily to avoid position bias. A closed-circuit television installation was used to remotely monitor coyotes from within a nearby building. To accustom the coyotes to rabbits as a source of food and to determine if a bias existed toward one color of prey, each coyote was permitted to kill and feed on both rabbits daily for at least 10 days. During this preconditioning period, the coyote wore a dummy collar with the same general weight and configuration as the high-voltage collar. Then the high-voltage collar was substituted, and the coyote was given daily 1-hour discriminated punishment sessions during which it was permitted to kill and eat the white rabbit but punished by electric shock for 0.5-1.0 second immediately after each attempt to kill the black rabbit. Punishment continued until each coyote had completed four successive daily 1-hour sessions during which the coyote selected only the white rabbit and made no attempt to kill the black one. A kill attempt was defined as a quick movement by the coyote toward the rabbit before actual oral contact. After the conditioning criterion was met, the dummy collar was again substituted for the high-voltage one, and the coyote was put back on a dry dog food diet except when tested at intervals for retention of the conditioning.

Retention tests were conducted beginning at 4, 8, 12, 20, 28, and 36 weeks after conditioning. Before each test, dog food was removed and the coyote was fed half a skinned rabbit each day for 2 days. Each retention test consisted of five consecutive daily sessions in which the coyote was again presented with a white and black rabbit for 1 hour. If the coyote completed at least four of these five sessions without attempting to kill the black rabbit, retention tests were continued. When it failed to meet this criterion, it was eliminated from the study.

RESULTS

From three to five shocks were required to condition coyotes 1, 2, and 3 to avoid black rabbits (Table 1). During the 10-day preconditioning period, these three animals had

Table 1. Acquisition and retention of avoidance conditioning in penned coyotes trained to avoid black rabbits.

Conditioning period:		Five-day retention tests: Time begun after conditioning and No. rabbits killed											
Day and No.		4 weeks		8 weeks		12 weeks		20 weeks		28 weeks		36 weeks	
Coyote number	Shocks given	White	Black	White	Black	White	Black	White	Black	White	Black	White	Black
1 (♀)	1 1 1 0	4	4*	5	0	5	1	5	4+	-	-	-	-
2 (♀)	3 1 0 1	5	0	5	0	5	4+	-	-	-	-	-	-
3 (♂)	2 0 0 2	5	0	5	0	5	0	5	0	5	0	5	2+
4 (♂)	2 1 0 0	4	3+	-	-	-	-	-	-	-	-	-	-

* Transmitter box (for shock delivery) not in pen and coyote killed all rabbits for 4 days; dummy boxes therefore installed in pens for all other retention tests.

+ Failed to meet test criterion (avoiding black rabbits for a least 4 of the 5 days); taken off test.

killed all black and white rabbits presented to them; coyote 4 had killed all ten black rabbits but only seven white ones. Because no coat color preference was shown by three coyotes, and only a slight black rabbit preference shown by the fourth animal, coat color was not counterbalanced during the punishment periods. After coyote 4 received three shocks for killing the black rabbits during conditioning, it avoided both black and white rabbits for 10 days (even though no other food was available) and was then placed back on dog food. Four weeks later, this animal was again presented with black and white rabbits for 5 days, killed both indiscriminately, and was eliminated from the study.

Coyote 1, the first animal tested, provided an example of the importance of visual cues in avoidance conditioning. The electric shock was administered from the nearby building through a cable terminating in the 27-MHz transmitter, which was enclosed in a small styrofoam box with projecting antenna suspended from an upper corner of the pen. After coyote 1 met the conditioning criterion, the box and antenna were removed from its pen and were absent during the first retention test 4 weeks later. During this test it killed both black and white rabbits for 4 days, but we noted that it frequently looked up at the corner where the box and antenna had been located. We therefore stopped the 4 week test and installed a dummy box and antenna in the same corner. Because this coyote then successfully met the retention criterion during the next two tests (at 8 and 12 weeks), the transmitter unit was replaced with dummy boxes in the other three coyotes' pens as soon as they were conditioned. With the dummy boxes in place, coyote 1 avoided black rabbits through 12 weeks, coyote 2 through 8 weeks, and coyote 3 through 28 weeks (Table 1).

DISCUSSION

Solomon and Wynne (1953) in their traumatic avoidance conditioning work with dogs, found extremely long retention of inactive-cued avoidance response. Our coyote data on passive-cued avoidance are in agreement in terms of a long retention effect for canids. The suppression of specific rabbit-killing behavior in this study was achieved through a response-contingent punishment procedure. Myer (1971), who compared the effectiveness of noncontingent, stimulus-contingent, and response-contingent punishments for suppressing mouse-killing by rats, found that immediate response-contingent shock produced the most rapid conditioning and resistance to recovery of the punished response during extinction. Our study was designed to maximize the effectiveness of punishment for modifying predatory behavior by following the recommendations of Azrin and Holz (1966): (1) No escape from the punishment was possible because a shock-collar delivery system was used; (2) the shock was intense (7 000 V), although brief and subtetanzizing; (3) all predatory attacks on black rabbits were punished; (4) the shock was delivered as soon as the predatory attack began and before ingestion; (5) a mild food deprivation schedule was used; and (6) the responses of attacking, killing, and eating the white rabbits were as reinforcing as the same responses toward the black rabbits.

When subjected to this optimal punishment procedure according to this design, three of the four test coyotes stopped attacking black rabbits after only three to five shocks and did not begin attacking them again until 3 to 9 months later. These results indicate that coyotes can rapidly learn to associate visual cues from negative prey with aversive consequences, at least when alternative prey is available, and display long retention of the punishment experience without further reinforcement. Although these tests were designed to produce the desired avoidance response as efficiently as possible, the rapid acquisition and relatively long retention of this response suggests that wild coyotes who have developed a pattern of killing sheep may be conditioned to avoid this class of prey by relatively few experiences with a severe noxious stimulus, particularly one that produced strong aversive consequences almost immediately after attack. Along these lines, our more recent research efforts have been directed toward the use of aversive chemical agents that can be delivered to coyotes attacking sheep under field conditions, as suggested by the work of Gustavson et al. (1974).

LITERATURE CITED

- AZRIN, N.H., and W.C. HOLZ. 1966. Punishment. IN: Operant Behavior: Areas of Research and Application (Ed. by W.K. Honig). Appleton-Century Crofts, New York.
- BROGDEN, W.J. 1949. Acquisition and extinction of a conditioned avoidance response in dog. *J. Comp. Physiol. Psychol.* 42:296-302.
- GUSTAVSON, C.R., J. GARCIA, W.G. HANKINS, and K.W. RUSINIAK. 1974. Coyote predation control by aversive conditioning. *Science* 184:581-583.

- KELLOGG, W.N., and I.S. WOLF. 1939. The nature of the response retained after several varieties of conditioning in the same subjects. *J. Exp. Psychol.* 24:366-383.
- MYER, J.S. 1971. Some effects of noncontingent aversive stimulation. IN: *Aversive Conditioning and Learning* (Ed. by F.R. Brush). Academic Press, New York.
- SOLOMON, R.L., L.J. KAMIN, and L.C. WYNNE. 1953. Traumatic avoidance learning: the outcome of several extinction procedures with dogs. *J. Abnorm. Soc. Psychol.* 48:291-302.
- _____, and L.C. WYNNE. 1953. Traumatic avoidance learning: acquisition in normal dogs. *Psychol. Monogr.* 67: (354): 19.
- _____, and L.C. WYNNE. 1954. Traumatic avoidance learning: the principles of anxiety conservation and partial irreversibility. *Psychol. Rev.* 61:353-385.