

University of Nebraska - Lincoln

DigitalCommons@University of Nebraska - Lincoln

---

Final Reports & Technical Briefs from Mid-  
America Transportation Center

Mid-America Transportation Center

---

2017

## Design and Implementation of the Manitoba Constrained-Width Tall Wall Barrier

Harald P. Larsen

Scott K. Rosenbaugh

Andrew Pankratz

Diana Emerson

Jennifer Schmidt

*See next page for additional authors*

Follow this and additional works at: <https://digitalcommons.unl.edu/matcreports>



Part of the [Civil Engineering Commons](#), and the [Transportation Engineering Commons](#)

---

This Article is brought to you for free and open access by the Mid-America Transportation Center at DigitalCommons@University of Nebraska - Lincoln. It has been accepted for inclusion in Final Reports & Technical Briefs from Mid-America Transportation Center by an authorized administrator of DigitalCommons@University of Nebraska - Lincoln.

---

**Authors**

Harald P. Larsen, Scott K. Rosenbaugh, Andrew Pankratz, Diana Emerson, Jennifer Schmidt, Ronald K. Faller, and Elizabeth M. Regier

---

---

**Design and Implementation  
of the  
Manitoba Constrained-Width Tall Wall Barrier**

Submitted by:

Authors:

Harald P. Larsen, P.Eng.  
Roadside Safety Engineer

Scott K. Rosenbaugh, M.S.C.E., E.I.T.  
Research Associate Engineer

Manitoba Infrastructure  
Traffic Engineering  
420 – 215 Garry Street  
Winnipeg MB R3C 3P3

Midwest Roadside Safety Facility  
Nebraska Transportation Center  
University of Nebraska-Lincoln  
130 Whittier Research Center  
2200 Vine Street  
Lincoln, Nebraska 68583-0853

Co-authors:

Andrew Pankratz, P.Eng.  
Senior Bridge Design Engineer

Diana Emerson, P.Eng.  
Traffic Services Engineer

Manitoba Infrastructure  
Structures Branch  
600 – 215 Garry Street  
Winnipeg MB R3C 3P3

Manitoba Infrastructure  
Traffic Engineering  
420 – 215 Garry Street  
Winnipeg MB R3C 3P3

Jennifer D. Schmidt, Ph.D., P.E.  
Research Assistant Professor

Ronald K. Faller, Ph.D., P.E.  
Research Associate Professor  
MwRSF Director

Elizabeth M. Regier  
Undergraduate Research Assistant

Midwest Roadside Safety Facility  
Nebraska Transportation Center  
University of Nebraska-Lincoln  
130 Whittier Research Center  
2200 Vine Street  
Lincoln, Nebraska 68583-0853

Paper prepared for presentation

at the Innovations in Road Safety Session

of the 2017 Conference of the  
Transportation Association of Canada  
St. John's NL

---

## Abstract

Manitoba Infrastructure (MI) desired a new, tall concrete median barrier capable of satisfying the Test Level 5 (TL-5) safety requirements of the Manual for Assessing Safety Hardware (MASH). It needed to fit within the footprint of an existing F-shape median barrier located in a narrow median. It also was required to address headlight glare from opposing traffic. The barrier was designed with a height of 1,250 mm, a maximum width of 600 mm and to resist a load of 845 kN applied at the top of the barrier. The Manitoba Constrained-Width, Tall Wall was optimised to withstand the design load while minimising the amount of steel reinforcement. Variations of the barrier were developed, including a bridge rail and a roadside barrier.

The bridge rail was considered to be the critical design due to its narrow width and anchorage to a relatively thin, cantilevered bridge deck. Thus, one full-scale vehicle crash test was conducted on the bridge rail system to verify the entire family of barriers. A vertical back barrier (45.72 m long) was constructed. It had a height of 1,250 mm and widths of 450 mm at its base and 250 millimetres at the top. The upstream half of the barrier (22.86 m) was constructed on a simulated bridge deck that was 280 mm thick. A gap in the bridge rail was constructed that was 168 mm wide and a gap in the bridge deck that was 19 mm wide; these were placed mid-span to simulate an expansion joint. A steel cover plate was placed over the barrier joint to prevent vehicle snag. During the test, the tractor trailer impacted just upstream from the joint and was safely redirected. The barrier sustained minor damage in the form of cracks and spalling.

Anchorage options were developed for use with the TL-5 barrier system, including a foundation slab and an independent footing. Transition systems were also detailed for the connection of the TL-5 median barrier to various other new and existing barrier shapes. Finally, Manitoba Infrastructure developed a full series of barrier systems for median and roadside conditions that will provide designers many options to create construction drawings for their projects that are specific for their site(s).

## 1 INTRODUCTION

### 1.1 Background

The current rigid median barrier Manitoba Infrastructure (MI) used along its roadways is the symmetrical F-shape concrete barrier that is 815 mm tall. However, an increased barrier height is often desired in medians as a means to eliminate some headlight glare from opposing traffic. Increases to the volume of truck traffic have also increased the need to use a barrier system capable of containing heavy trucks. Thus, MI desired a tall concrete barrier that satisfied the Test Level 5 (TL-5) safety requirements found in the American Association of State Highway and Transportation Officials (AASHTO) *Manual for Assessing Safety Hardware (MASH)* [1].

MI conducted a review of previously designed TL-5 barriers and elected to alter the cross section shape of its barrier from the current F-shape to a constant slope shape. The State Departments of Transportation for both California and Texas have developed high containment, concrete median barriers using a constant slope on the front face of the barrier [2-4]. Both barriers have a height of 1,067 mm, but they differ slightly in face geometry as the slopes measure 9.1 and 10.8 degrees from vertical, respectively. However, MI required a taller barrier to reduce headlight glare. Using the guidelines provided in National Cooperative Highway Research Program's (NCHRP) *Synthesis of Highway Practice 66 Glare Screen Guidelines* [5], MI desired a barrier height of 1,250 mm. MI also required a footprint width of 600 mm for the

---

new barrier to match current roadway median geometries. Thus, MI desired to modify the California Single-Slope barrier to match these geometric requirements.

To undertake this work, MI entered into a research project with Midwest Roadside Safety Facility (MwRSF) at the University of Nebraska – Lincoln as its Engineering Service Provider [6]. The major components of this project involved: 1) research of existing comparable barrier systems; 2) design of the new barrier, and 3) full scale crash testing to obtain the necessary MASH TL-5 compliance.

Variations of both constant slope barriers have previously been developed by other transportation agencies desiring high-capacity concrete barriers. However, the barrier height has not typically been altered. Increasing the barrier height above the standard 1,067 mm would likely restrict the amount of roll experienced by the tractor trailer during redirection and increasing the load imparted to the barrier by the impacting vehicle. Also, taller barriers may potentially result in an increased applied load height. Impacts with barriers that are 1,067 mm tall have resulted in the box extending over, and leaning on the top of, the barrier during redirection. With a taller barrier, the trailer box could impact the barrier laterally and apply loads near the top of the barrier. An increased applied load height would require more anchorage strength to prevent barrier overturning. Subsequently, in order to increase the height of a TL-5 barrier, additional reinforcement and barrier anchorage may be required to maintain the structural integrity of the system.

Finally, MI desired to use the new barrier system in a variety of different installation applications, including as a median barrier, roadside barrier, and bridge rail. Therefore, a new family of MASH TL-5 concrete barriers needed to be developed to satisfy MI's geometric desires and encompass multiple installation configurations. Along with the family of TL-5 barriers, transitions would be needed to attach the new barrier system to existing barriers and/or new lower-height (lower test level) barriers with the same base width of 600 mm and constant slope face angle of 9.1 degrees.

## **1.2 Objective**

The objective of this research, design and testing effort was to develop a tall, constant slope, concrete barrier system to satisfy MASH TL-5 safety performance criteria. The barrier was to be modeled after the California Single-Slope barrier, have a height of 1,250 mm and have a maximum base width of 600 mm. The footprint limitation was to ensure the new barrier did not encroach onto the adjacent median lanes beyond the existing encroachment of the F-shape barrier at its toe.

MASH TL-5 requirements are such that a barrier is structurally adequate to contain and redirect a 36000 kg tractor-van trailer impacting at 80 km/h and 15 degrees to the barrier; the test vehicle should not penetrate, override or underide the barrier installation. Detached elements from the test barrier should not penetrate, or show potential for penetrating, the impacting vehicle or pose a hazard to other vehicles, pedestrians. It is also preferable the test vehicle remain upright during and following the impact.

The MASH TL-5 barrier must also satisfy impact requirements of TL-3 which involve a 2270 kg pickup truck and an 1100 kg passenger car. Both TL-3 vehicle tests impact at 100 km/h and 25 degrees. These tests for TL-3 require the vehicle to remain upright, and produce acceptable occupant impact velocities as well as acceptable occupant ride down accelerations. Table 1 summarises these test criteria, along with the remaining MASH test levels.

---

Multiple configurations of the new barrier system were desired including median, roadside, and bridge rail applications. Both interior and end (adjacent to discontinuities) sections were to be developed. Furthermore, a bridge deck with minimal thickness and maximum cantilever overhang distance was desired to support the new bridge rail. Finally, transitions from the new TL-5 barrier to various existing barrier structures were to be developed.

### **1.3 Scope**

The research objective by MwRSF was achieved by performing several tasks. First, a literature review was conducted on previous crash tests involving tractor trailer vehicles impacting bridge rails, roadside barriers, and median barriers. Next, the barrier width and reinforcement configuration was optimised to minimise installation costs while satisfying MASH TL-5 structural requirements. Design efforts focused on a single-sided (vertical back) bridge rail configuration since narrower barriers are more likely to sustain damage during impact events than wider, symmetrical barriers. A full-scale crash test was then conducted with a 36,000 kg van-type tractor trailer impacting a bridge rail installation that was 45.72 m long according to MASH test no. 5-12. The successfully-tested TL-5 bridge rail was modified into multiple other configurations, including median and roadside applications. Finally, multiple transitions were developed to attach the new TL-5 barriers to various new and existing concrete barrier systems.

MI then developed a suite of standard median and roadside barrier designs to be used along its roadways off bridges.

### **1.4 Barrier Design Considerations**

Roadside safety features, including barriers, must be cost-effective to not place unnecessary financial burdens on traffic authorities. As such, designs must consider: 1) uniformity of components; 2) ease of construction; and 3) technology.

While almost everything is technologically possible, the ease of construction and uniformity of components may limit the use of new technology. Also, using new technology for barrier designs may not provide a satisfactory result during crash testing that would be required for MASH compliance and would therefore require subsequent redesign of the barrier and retesting at significant cost with no guarantee of success.

All acceptable barriers must be: structurally adequate; not expose vehicle occupants to any undue risk; and consider vehicle trajectory after the impact. The vehicle trajectory after the impact relates to the impacting vehicle itself such as exit angle and whether the barrier contained the vehicle.

There are as many as six different aspects of the crash that relate to occupant risk depending on the test level. It ranges from decelerations/accelerations of the occupants to any debris of detached parts of the barrier that may enter the passenger compartment or affect other vehicles.

Structural adequacy falls under three different facets. This deals with vehicle containment and redirection, how the barrier engages the impacting vehicle, and whether the barrier redirects or decelerates the impacting vehicle all relative to specific test levels. If a barrier is structurally adequate for the TL-5 test, then it follows that the lower test levels would be structurally satisfied.

---

With the existing knowledge gained from previous research and crash testing, the California Single-Slope barrier had already proven itself to be a suitable device for consideration regarding vehicle trajectory and risk to occupants for TL-3 and TL-5. It also demonstrates better performance than typical safety shape barriers which introduce significant vertical lift and roll action onto the impacting vehicle particularly for the smaller vehicles. Since this new barrier was to be considered for installation on a cantilevered bridge deck its structural adequacy remained unknown to provide TL-5 compliance. Thus, to obtain TL-5 compliance, the bridge deck design at an expansion joint was considered the critical design element and only one barrier design for the van-style tractor trailer vehicle would be developed and tested as the kinetic energy from TL-3 to TL-5 increases tenfold.

## **2 LITERATURE REVIEW**

At the onset of the project, a literature review was conducted on previously crash-tested, TL-5 barrier systems. The review focused on testing of van-style tractor trailers impacting bridge rails and concrete roadside and median barriers. Nine tests on bridge rails and four tests on concrete median barriers were reviewed. Eleven of the tests were conducted according to the criteria of National Cooperative Highway Research Program (NCHRP) Report No. 350 [7], which are the same for test no. 5-12 in the current MASH standard. The remaining two tests were conducted in accordance with the 1989 edition of AASHTO's *Guide Specifications for Bridge Railings* [8]. The latter guide used a 22,680 kg tractor trailer while NCHRP Report No. 350 and MASH required a vehicle weight of 36,000 kg. All 13 of these crash tests resulted in vehicle redirection and satisfactory barrier performance.

The literature review also considered the geometry and strength of each of these high-containment barrier systems. The geometric shape, height, and width of each barrier were documented along with the mass, speed, and angle of the impacting vehicle. Deck thicknesses and cantilever overhang distances were also recorded for the nine bridge rails. The material strengths and reinforcement configurations were also documented in order to calculate barrier and deck strengths. System strengths were used in establishing the design strength for the new Manitoba barrier and are discussed in Chapter 3. Finally, the damage sustained by each system was documented in order to compare performances between the barrier systems.

## **3 DESIGN CRITERIA**

### **3.1 Geometric Requirements and Material Specifications**

Although median barrier, roadside barrier, and bridge rail configurations were all desired for the new MASH TL-5 concrete barrier, the bridge rail was considered the most critical design as it had a vertical back with the narrowest cross section, thus requiring the most anchorage strength. This critical design became evident at parallel bridges with a nominal separation between structures of opposing traffic that could not accommodate a symmetrical constant slope barrier but required two vertical back barriers essentially back-to-back. The bridge rail was also required to be attached to a relatively thin, cantilevered bridge deck, which was more susceptible to damage than a foundation slab or footing used for the median or roadside applications. Thus, design and testing was to focus on the vertical back bridge rail configuration. Then, pending a successful crash test, the other configurations would be designed to have equivalent strength as the bridge rail. Both interior and end (adjacent to discontinuities) sections of the barrier were designed. Discontinuities in barriers occur at the upstream and downstream ends as well as at expansion joints of many bridge decks.

---

The new median and roadside barriers and bridge rail systems were required to be based on a symmetrical cross section with a height of 1,250 mm and a maximum base width of 600 mm. The barrier was to have a constant slope face geometry with a 9.1 degree (4V:25H) slope from vertical, creating a lateral offset from its base to its top of 200 mm. The bridge deck was to have a minimum thickness of 250 mm, and the backside of the critical barrier design was to be offset from the edge of the deck by 50 mm. Barrier reinforcement was to consist of both longitudinal and transverse steel with additional reinforcing bars required to anchor the barrier to the deck.

System discontinuities can create higher stresses and a greater risk of component failure. Thus, the full-scale test was to be conducted on a test installation incorporating an expansion and contraction joint in both the bridge rail and the bridge deck. Typical joints in MI bridge decks were an average of 215 mm wide and consisted of steel components used to transfer shear across the joint. Concrete barriers cannot be cast directly on these adjustable steel joints, so gaps the size of the steel joint hardware were often left in the barrier system. Therefore, a similar width gap was to be placed within the test installation.

Development of a steel cover plate was desired to span across the open joint in the barrier and protect a vehicle from snagging on exposed ends of the barrier. The cap would be anchored only to the upstream side of the joint to allow the joint to expand and contract. A steel cover plate design currently used by MI served as the basis for the barrier joint design on this project.

The new TL-5 barrier was to be designed, constructed, and evaluated with materials in compliance with MI's standard specifications. MI specifies that 35 MPa concrete design strength be used for its bridge decks and concrete bridge barriers in the design process. However for construction, the Department also requires the minimum concrete design strength be increased to 45 MPa for enhanced durability. Since the as-constructed concrete design strength is 45 MPa, or greater, for current bridge barriers, it was thought more prudent to crash test a barrier using the higher concrete design strength as this would be more representative of the as-constructed barriers. Thus, the concrete was required to have a minimum compressive strength of 45 MPa. Reinforcement of the barrier was to consist of Steel Grade 400W rebar with sizes between 10M and 20M. Transverse steel bars were to be spaced at intervals divisible by 50 mm with a 100 mm minimum spacing. Steel reinforcement required 75 mm of concrete cover with the exception of a 50 mm cover allowance for the bottom layer of the bridge deck reinforcement.

### **3.2 Barrier Design Strength**

Barrier strengths were calculated for previously designed and successfully crash tested TL-5 barriers. Barrier capacities were calculated using Yield Line Theory, a common analysis method for concrete barriers and recommended by the AASHTO LRFD Bridge Design Specifications [9]. The list of 13 barriers was pared down to include only the five barriers tested to the current MASH TL-5 impact criteria and avoid barriers that may not satisfy current strength requirements. Barrier systems containing either steel rail components or Fiber Reinforced Polymer (FRP) reinforcement were also disregarded as these systems would require different analysis techniques. Although the California Single-Slope barrier was never crash tested with heavy vehicles, it has been widely considered to be a TL-5 barrier and has been listed in the *AASHTO Roadside Design Guide* [10] as a TL-5 barrier. Thus, the California Single-Slope barrier was included in the barrier strength analysis.



---

Research work conducted by TTI identified a peak load applied in a TL-5 test was 980 kN. Four of the five barriers had design strengths below 980 kN but all barriers were within 10 percent of this measured value. Only one of the five tested TL-5 barriers sustained heavy damage during the impact, as the open concrete rail evaluated in test no. ACBR-1 showed rail, post, and deck damage. Damage to the other four barriers consisted of only contact marks, gouging, and minor cracking. Therefore, Yield Line Theory was thought to underestimate the actual capacity of a concrete barrier, especially for closed shaped barriers, and the design strength required of a concrete barrier to satisfy MASH TL-5 is likely lower than the strength of existing TL-5 barrier systems. In recognition of the conservative nature of Yield Line Theory and through consultation between MwRSF and MI, a minimum design load of 845 kN was selected for the new MI TL-5 barrier.

### **3.3 Deck Design Strength**

The strength of a bridge deck supporting a TL-5 concrete bridge rail must satisfy three design cases in order to comply with the *AASHTO LRFD Bridge Guide Specifications* [9]:

1. A lateral load of 552 kN applied to the face of the bridge rail and transferred down to the deck as both a shear force and moment.
2. A vertical load of 356 kN applied to the cantilever portion of the bridge deck
3. The bending strength of the deck must be equal to, or greater than, the overturning moment strength of the barrier ( $M_c$  term in Yield Line analysis of the barrier).

In practice, the first two design cases rarely control the design strength of the bridge deck. Design Case 2 only controls for decks with large cantilever distances (i.e., greater than 2 m between the edge of the outer most girder and the edge of the deck). The required lateral load in Design Case 1 is much lower in magnitude than the targeted design strength of the barrier (845 kN) so it would not control the deck design strength either. Therefore, Design Case 3 typically controls the required strength of the bridge deck.

Previous crash testing has demonstrated the ability of bridge decks with bending strengths lower than the barrier  $M_c$  to support TL-5 impacts without damage. Three of the reviewed crash tests featured bridge decks with strengths significantly lower than that provided by the barrier (strength ratios less than 1.0). Two of these decks with reduced capacity had strength ratios of 0.71 and 0.85 and sustained no structural damage during the full-scale crash test. Thus, previous testing has demonstrated the ability of decks with only 71 percent of the barrier  $M_c$  to adequately support the barrier impact events. Once again, consultation between MwRSF and MI determined that the deck strength to be selected for its design strength would be 85 percent of the barrier  $M_c$  for the new TL-5 bridge rail.

## **4 BARRIER ANALYSIS AND DESIGN**

### **4.1 Bridge Rail Design**

Through discussions with the researchers at MwRSF, a general barrier configuration was established for the new TL-5 bridge rail to test. The rail would be a constant slope barrier with a vertical back and 1,250 mm tall. Steel reinforcement would consist of both longitudinal bars and transverse stirrups. The stirrups would be U-shaped with the open ends extending into the narrow top of the rail. Minimum bend radii for larger bars prohibited a continuous loop stirrup from fitting inside the narrow top of the barrier. A sketch of the general configuration is shown in Figure 1.

---

Variables within the general design configuration included barrier width, size and number of longitudinal bars, and size and spacing of the transverse steel U-bars. For a median (symmetrical) configuration, a top width of 200 mm resulted in the maximum targeted base width of 600 mm. However, a narrower, configuration that was asymmetrical with a vertical back occupied less space and could be widened without unacceptably encroaching towards traffic. Thus, barrier top widths of both 200 mm and 250 mm were considered. Top widths greater than 250 mm were undesirable.

All steel reinforcement was to consist of bar sizes ranging between 10M and 20M. The barrier longitudinal steel was to consist of either 10 or 12 bars, divided evenly between the front and back sides of the barrier. These quantities created desirable bar spacings between 200 mm and 300 mm along the height of the barrier. The transverse steel U-bars were to be spaced at intervals divisible by 50 mm with a minimum spacing of 100 mm (e.g., 100 mm, 150 mm, 200 mm, etc.).

The bridge rail design was optimised to satisfy the minimum design strength of 845 kN and to minimise the cost of the barrier system. The strength of the various configuration possibilities was calculated using Yield Line Theory, as recommended by the *AASHTO LRFD Bridge Design Specifications* [9], assuming the lateral impact load was applied to the top of the barrier at a height of 1,250 mm and distributed over a length of 2.4 m of the barrier. Construction costs for the various configurations were thought to be closely related with the amount of steel reinforcement within the barrier. Thus, the amount of steel in each configuration was calculated per unit length, kg/m, and these values were used to compare the relative costs of each design configuration.

Design configurations were analysed using an iterative approach, changing only one variable at a time. For a specific width, longitudinal rebar configuration, and stirrup bar size, the largest stirrup spacing to satisfy a strength requirement of 845 MPa was determined. The resulting barrier configuration was documented, and the amount of steel per unit length was calculated. This process was repeated for each possible combination of barrier width, longitudinal bar size, longitudinal bar quantity, and stirrup size. Since design configurations for both interior and end sections were required for the new bridge rail, the entire procedure was conducted twice, once with the Yield Line equation for interior sections and the second time with the equation for end sections.

Early in the analysis procedure, it was noted that 10M bars, when used as longitudinal steel or stirrups, did not provide enough strength to satisfy a design load of 845 kN. As such, 10M bars were removed from the list of possible bar sizes, and only 15M and 20M bars were considered.

As expected, the design configurations with a top width of 250 mm tended to contain less steel than the top width designs of 200 mm. The increased width resulted in increased strength and decreased the required steel by an average of 4 kg/m for interior sections and 10 kg/m for end sections. This reduction in steel was more than enough to offset the cost of the additional concrete required for a wider barrier. Thus, the top width designs of 250 mm were favoured over the narrower widths.

The barrier configuration that resulted in the lowest amount of steel used a top width of 250 mm, ten 15M longitudinal bars, and 20M stirrups spaced at 400 mm. This interior configuration required only 29.7 kg/m of steel, about 1 kg/m less than any other design. This configuration also allowed for a stirrup spacing 150 mm larger than the configuration with the second lowest

---

amount of steel, thus requiring less steel ties. Therefore, this configuration was identified as the optimal design for interior barrier sections.

For construction purposes, it was desired to keep the longitudinal steel the same for both the interior and end section configurations. Ideally, only the stirrup spacing would be reduced for end sections adjacent to rail discontinuities. Conveniently, the end section configuration that resulted in the second lowest amount of steel matched perfectly with the optimal interior configuration. This end section was identical to the interior section, except the stirrup spacing was reduced from 400 mm to 200 mm or half of the interior section configuration. Therefore, the combination of these two configurations, were selected as the optimal designs for the new TL-5 bridge rail and were recommended for further evaluation through full-scale crash testing.

During the Yield Line analysis of the barrier end section, a critical length,  $L_{CR}$ , of 2.7 m was calculated. Thus, it was recommended that the end section configuration with a reduction in the stirrup spacing extend at least 2.7 m from any rail discontinuity.

Although the strength analysis herein was conducted assuming a load height of 1,250 mm, it was recognised that other designers may use different load heights and different design loads. For comparison purposes, the strength of the selected interior design configuration was also calculated assuming load heights of 860 mm and 1,090 mm. These applied load heights resulted in strength capacities of 1,143 kN and 970 kN, respectively.

## **4.2 Deck Design**

An optimised bridge deck was designed to support the new TL-5 bridge rail. The deck was required to be a minimum thickness of 250 mm and contain an upper and lower mat of steel reinforcement. The upper and lower mats were to have concrete covers of 75 mm and 50 mm, respectively. The longitudinal steel in both reinforcement mats was specified to be 15M bars spaced at 350 mm, which was typical of large bridges in Manitoba. The lateral steel bar configurations needed to be designed to support the new bridge rail.

As discussed previously in Section 3.3, the design strength for the bridge deck was established as 85 percent of the overturning strength of the bridge rail,  $M_c$ . The bridge rail designs selected for further evaluation in Section 4.1 had  $M_c$  strengths of 135 kNm/m and 259 kNm/m for the interior and end section configurations, respectively. By multiplying these  $M_c$  values by 0.85, the deck design strengths were established as 114 kNm/m for regions supporting interior bridge rail sections and 220 kNm/m for regions supporting end sections near discontinuities.

For constructability purposes, it was desired for the lateral steel bars in the deck to be spaced to match the barrier stirrups so that transverse steel from both structures could be tied together. Thus, the lateral bars in the deck were targeted for placement at intervals of 400 mm and 200 mm for interior and end sections, respectively. However, in order to satisfy the design strength requirements for the deck, the lateral steel in the top mat was doubled, which still allowed every other bar to be tied to the barrier stirrups.

The selected deck configuration was 280 mm thick and consisted of 20M bars spaced at 200 mm along the top mat of steel and 15M bars spaced at 400 mm along the bottom mat. This configuration gave the interior deck section a strength of 121 kNm/m. Similar to the bridge rail reinforcement, the lateral steel bars in the deck end section were doubled, resulting in a spacing of 100 mm for the 20M bars and 200 mm for the 15M bars. The deck end section had a calculated strength matching the targeted design strength of 220 kNm/m.

---

The distance of the deck overhang, the cantilever portion of the barrier adjacent to the edge of the deck, was desired to be 1,300 mm. This distance represented the largest of the overhang lengths typically used by MI. Using a distance of 1,300 mm, the dead weight of the barrier, and the 356 kN vertical load recommended by loading Case 2 of the *AASHTO LRFD Bridge Guide Specifications*, resulted in a design load of 58 kNm/m. This design load was only 50 percent of the strength of the deck, so the 1,300 mm overhang distance was acceptable for use with the new TL-5 bridge rail and deck designs.

### **4.3 End Section Design for Testing**

Expansion and contraction joints in concrete barriers create discontinuities and weak points within a barrier system. Thus, full-scale crash testing was intended to be conducted with the tractor trailer vehicle impacting just upstream from a simulated joint in the bridge rail and deck. However, the calculated strength of the barrier end section was higher than that of the interior sections, 983 kN as compared to 874 kN. An argument could have been made that the interior section was weaker than the end section. To ensure the interior section could withstand a TL-5 impact, the design of the barrier end section was altered only for the full-scale crash test. By extending the spacing of the barrier stirrups from 200 mm to 230 mm, the design strength of the end section was reduced to 874 kN, matching the capacity of the interior section. This configuration was used for full-scale crash testing, but the recommended configuration for real-world installations would still use the original spacing of 200 mm. The spacing of the lateral steel bars in the deck were also increased to match the transverse steel in the barrier end sections.

The critical length,  $L_{CR}$ , was calculated to be 2.7 m from Yield Line analysis for the end section. Thus, for the test installation, the transverse stirrups were spaced at 230 mm for a distance of 2.86 m on each side of the open joint.

## **5 DESIGN DETAILS**

The test installation consisted of a reinforced concrete vertical back bridge rail installed on a simulated concrete bridge deck. The total length of the barrier was 45.72 m. The upstream half of the barrier was installed on a simulated cantilevered reinforced concrete bridge deck, while the downstream half was installed on the concrete tarmac. Photographs of the test installation are shown in Figure 2.

The bridge rail had a height of 1250 mm and was a constant slope, vertical back barrier, with a traffic face slope measuring 9.1 degrees from vertical. The bridge rail was 250 mm wide at the top and 450 mm wide at the bottom, which matched the Department's current TL-4 vertical back F-shape barrier used on bridge decks. Barrier reinforcement consisted of both longitudinal bars and U-shaped stirrups. All barrier reinforcement had a concrete cover of 75 mm. The edges of the bridge rail contained 20 mm chamfers, and the back of the barrier was 50 mm from the edge of the bridge deck.

The bridge rail contained a simulated expansion/contraction joint consisting of an open gap in the barrier that was 168 mm wide. This distance was selected to represent typical widths of gaps in real-world installations and to match up with the transverse steel reinforcement in the deck without requiring an abnormal rebar spacing. A cover plate, fabricated from steel that was 13 mm thick, was placed over the joint and bolted to the upstream side of the barrier. The leading edge of the cover plate cap was chamfered to prevent vehicle snagging. End section

---

reinforcement, characterised by a reduced stirrup spacing, was used for a distance of 2.86 m both upstream and downstream from the open joint.

The simulated cantilevered bridge deck was 2.9 m wide, 280 mm thick, and 22.86 m long. The inner section of the bridge deck was anchored to the adjacent concrete tarmac using epoxied dowel bars. The middle of the bridge deck was supported by a grade beam that was 600 mm tall by 600 mm wide in cross section. The cantilevered portion of the simulated bridge deck extended 1.3 metres past the grade beam. An open joint gap ran through the middle of the bridge deck measuring 19 mm wide to simulate a bridge expansion joint and aligned with the centre of the open joint in the rail. No connection hardware was used to connect the upstream and downstream halves of the bridge deck. The deck was reinforced with upper and lower steel rebar mats. End section reinforcement of the bridge deck, characterised by an increase in transverse steel bars, was placed underneath the barrier end sections on both sides of the joint.

The bridge rail, deck, and grade beam were all cast with a concrete mix that exceeded the required compressive design strength of 45 MPa after 28 days. Steel reinforcement in the bridge rail and deck consisted of Steel Grade 400W metric rebar, while the grade beam was reinforced with ASTM A615 Grade 60 rebar.

## **6 TEST REQUIREMENTS**

New barrier systems must satisfy the current roadside safety standards in order to be deemed crashworthy. According to the TL-5 evaluation criteria of MASH, longitudinal barrier systems, including concrete bridge rails, must be subjected to three full-scale vehicle crash tests, as summarised in Table 1.

Following a review of previous crash testing into concrete barrier systems, only the 36000V tractor trailer test was determined to be critical for the evaluation of the Manitoba TL-5 bridge rail. Even though test 5-12 is conducted at a lower speed and angle than the other tests, the large increase in mass of the 36000V vehicle results in an impact severity almost four times higher than the pickup truck test and about eight times higher than the small car test. Thus, test 5-12 would impart the highest impact loads to the barrier and be the critical test for evaluating the strength of the bridge rail and deck.

Vehicle stability was not considered to be critical for either of the passenger vehicles. Previous crash testing of the 2270P pickup into a constant slope concrete bridge rail of 11 degrees and a vertical faced concrete bridge rail both resulted in successful MASH tests with minimal vehicle roll and pitch displacements [11-12]. The 9.1 degree slope of the Manitoba bridge rail is between these two tested systems, so the vehicle performance in terms of stability has been effectively bracketed by the previous crash tests. Similarly, previous 1100C crash tests have been successfully conducted on a New Jersey-shaped concrete barrier and a vertical steel gate [13-14]. The New Jersey shape barrier has long been considered to cause more vehicle instabilities as they induce vehicle climb and roll during impact. With the small car remaining stable through impacts with a New Jersey barrier and a vertical-faced barrier, there was little concern for 1100C stability during impact with the Manitoba bridge rail. The National Cooperative Highway Research Program (NCHRP) *Web-Only Document 157* also determined single-slope barriers with a slope of 9.1 degrees to be crashworthy to MASH performance standards as long as they have adequate structural capacity [15]. Therefore, test nos. 5-10 and 5-11 were not deemed to be critical tests and were not conducted as part of this study.

---

## **7 TEST CONDITIONS**

MASH specifies that the critical impact point for a 36000V vehicle be selected to induce maximum loading to a critical portion of the barrier system. The maximum load from the vehicle impact was expected to occur when the rear tandem axles would strike the barrier, while the critical portion of the barrier was adjacent to the open joint in the rail and deck. Thus, the impact point was selected such that the rear tandem axles of the tractor trailer would impact the bridge rail upstream from the joint. Table 2.7 in MASH suggests that the rear tandem axles will impact approximately 0.3 m upstream from the vehicle's initial impact point. To further analyse this offset, a review was conducted on previous TL-5 crash tests conducted to NCHRP Report 350 and MASH safety standards, since they have the same impact conditions. The centre of the rear tandem axles of 36000V vehicles typically impact the barrier 0.3 m to 1.2 m upstream from the initial impact point. To ensure both axles of the rear tandem axles apply load to the upstream side of the joint, the centre of the rear tandem axles needed to impact the system approximately 1.2 m upstream from the joint. Thus, the initial impact point was selected to be 0.9 m upstream from the centre of the joint. This impact location also allowed for the evaluation of snag on the joint cover plate since the front wheels of the tractor would impact approximately 508 mm upstream from the front edge of the steel cover plate.

## **8 FULL-SCALE CRASH TEST NO. MAN-1**

### **8.1 Test Description and Results**

The full scale crash test, MAN-1, was conducted on April 13, 2016 at approximately 2:00 p.m. at MwRSF testing facility at Lincoln Air Park. The 36,322 kg van-type, tractor trailer impacted the bridge rail at a speed of 83.2 km/h and at an angle of 15.2 degrees. The initial vehicle impact was to occur 914 mm upstream from the midpoint of the barrier gap. This was selected to cause the rear tandems to impact and load the bridge rail just upstream from the open joint. The actual initial point of impact was 462 mm upstream from the joint.

Although the initial impact point occurred 452 mm downstream of the intended point and exceeded the MASH tolerance of +/- 305 mm, the intended impact point for the rear tandem axles (1.5 metres upstream of barrier gap) and maximum loading was satisfied. Therefore the test was considered to be acceptable.

### **8.2 Barrier Damage**

Damage to the test installation was minimal and consisted of contact marks, gouging of the concrete, concrete spalling, and minor concrete cracking. Concrete spalling occurred on the top of the barrier and varied, but had a maximum depth of 52 mm. None of the internal steel reinforcement was exposed.

Multiple hairline cracks were found on the barrier system, extending upstream and downstream from the joint. Barrier cracks were more prevalent nearest the barrier joint. All of the cracks in the barrier were less than 1.5 mm wide.

Damage to the steel cover plate was largely cosmetic, consisting of contact marks and scrapes. Only a small indentation was found on the chamfered edge of the cover plate at this location. The steel cover plate sustained no further gouging or deformations. The cap was removed for further inspection, but no further damage was observed. However, with the cover plate

---

removed, concrete cracks and minor spalling were found on the top surface of the barrier on both sides of the open joint.

The bridge deck sustained only minor cracking as a result of the impact. A series of longitudinal hairline cracks were found on the surface of the downstream half of the bridge deck located directly over the outside edge of the grade beam. Each individual crack was no longer than 450 mm but all together these cracks spanned a total length of approximately 3 m. Two cracks with a maximum opening width of 3 mm extended between the steel end cap and the open joint in the deck on the downstream side of the joint. These cracks continued through the thickness of the deck and merged into a single crack on the bottom surface of the deck. This crack extended 0.6 m downstream from the joint within the outer 50 mm of the bridge deck behind the barrier. The crack continued up the outside face of the bridge deck and diagonally back toward the joint until it reached the base of the barrier. The bridge deck upstream of the open joint experienced no visible cracking.

The permanent set of the barrier system was 0 mm, as measured in the field. The maximum lateral dynamic barrier deflection was 52 mm, as measured at the top of the barrier adjacent to the joint and determined from high-speed digital video analysis.

## **9 DATA ANALYSIS OF TEST NO. MAN-1**

### **9.1 Vehicle Roll**

Maximum roll angles of 16 degrees and 13 degrees for the cab and trailer, respectively were recorded. Previous TL-5 crash testing has typically resulted in significantly more vehicle roll. However, the vast majority of previously-designed and crash-tested TL-5 barriers used a shorter height of 1,067 mm. The average maximum roll angles for previous tests for trailers impacting a 1,067 mm tall barrier was calculated to be 36 degrees. All crash tests also had a maximum roll angle which was at least two times that observed in test no. MAN-1 for the Manitoba bridge rail. Thus, it is believed that the increased height of the Manitoba bridge rail contributed to a more stable redirection by reducing vehicle roll.

The working width of the system, defined as the furthest lateral extent of the vehicle beyond the front of the barrier, was found to be 949 mm as determined from high-speed digital video analysis. The zone of intrusion represents the area above and behind the barrier that a vehicle component may occupy during redirection. Since the top of the Manitoba Constrained-Width, Tall Wall is offset 200 mm from the front toe, the zone of intrusion for the barrier measures 749 millimetres laterally from the top front corner of the barrier and extends upward the full height of a tractor trailer vehicle, or approximately 4.1 m.

### **9.2 Impact Load Estimation**

The increased height of the Manitoba bridge rail likely affected the impact loads in two very distinct ways. First, since the trailer impacted the bridge rail laterally, the effective height of the impact load was increased. Impacts into barriers that are 1,067 mm tall typically result in the vehicle wheels providing the lateral load to the face of the barrier while the trailer extends over, and leans on top of, the barrier. With both the wheels and the trailer impacting the face of the Manitoba Constrained-Width Tall Wall, the effective height of the impact load was likely increased. Second, the reduced vehicle roll likely increased the magnitude of the impact load. By reducing the vehicle roll, the lateral displacement of the ballasted trailer was reduced and the time in which the lateral momentum of the ballasted trailer was stopped (with respect to the

---

barrier) was also reduced; a reduced impact time requires an increase in force. Therefore, the impact loads into the Manitoba bridge rail were likely greater in magnitude and applied at an increased effective height as compared to previous TL-5 impacts into typical barriers that are 1,067 mm tall.

## **10 DESIGN CONFIGURATIONS FOR MEDIAN AND ROADSIDE BARRIERS**

As part of the research project with MwRSF median barrier, roadside barrier, and bridge rail configurations of the Manitoba Constrained-Width, Tall Wall barrier system were desired. The bridge rail was developed first and selected for crash testing because it was considered to be the most critical of the configurations. After the successful crash test on the bridge rail, the other two configurations were developed with the same traffic face geometry and equivalent or greater strength.

### **10.1 TL-5 Median Barrier Configuration**

Design and analysis of the median barrier configuration followed a methodology similar to the development of the bridge rail. However, there were a few differences in the configuration options and the design strength. For a median (symmetrical) barrier, a top width of 200 mm resulted in the maximum targeted base width of 600 mm. The increased width of the median profile resulted in increased barrier strength and thus required less steel reinforcement. As such, 10M bars, which were originally eliminated from the bridge rail configuration options due to a lack of adequate strength, were re-considered for use in the median barrier. Finally, the median barrier was required to have the same or greater strength as the tested bridge rail configuration, or a calculated design strength of 874 kN instead of the original design strength of 845 kN.

The median barrier was optimised using the same process detailed in Section 4.1 for the bridge rail. Each configuration option was analysed using Yield Line analysis, and the maximum stirrup spacing to satisfy the design strength criteria was determined for each longitudinal rebar configuration and stirrup size combination. Finally, the amount of steel in each configuration was calculated per unit length, in kg/m, and these values were used to compare the relative costs of each design configuration.

Since the majority of an installation will be comprised of interior barrier sections, the selection of an optimal design focused on the interior section results. The median barrier analysis of interior sections resulted in a four-way tie for the lowest amount of steel, 22.7 kg/m (15.3 lb/ft). Looking at the end sections associated with these four designs, one configuration also had the lowest amount of steel for an end section. This configuration was also the only of the four configurations to consist of 10 longitudinal bars instead of 12, so it would require less steel ties. Therefore, the median barrier configured with ten 10M longitudinal bars and 20M stirrups spaced at 400 mm and 300 mm for the interior and end sections, respectively, was selected as the optimal design.

During the Yield Line analysis of the selected configuration, a critical length of 2.6 m was calculated for the end section. Thus, the end section reinforcement characterised by a reduced stirrup spacing should be used over a distance of at least 2.6 m. Incorporating a stirrup spacing of 300 mm and 75 mm of concrete cover, the length of the median barrier end section was specified to be 2.785 m.



---

To ensure proper performance, the median barrier should be anchored to a reinforced concrete foundation slab similar to the anchorage of the bridge rail to the deck. Two anchorage options were developed. Option 1 uses 15M dowel bars epoxied into the foundation slab, while Option 2 uses 15M U-bars cast into the foundation slab. The anchorage bars for either option were placed adjacent to each barrier stirrup. Both anchorage options require 200 mm of embedment, so a minimum thickness of 280 mm was recommended for the foundation slab. The foundation slab may be either an extension of, or tied directly to, the roadway slab in order to prevent rotation of the median barrier system. If the foundation slab is separate from any other roadway slabs, it should be at least 2 m wide and contain reinforcement comparable to the bridge deck to provide enough strength to support the median barrier system.

## 10.2 Alternative Anchorage Options for Median Barrier

Real-world installation sites may exist where the median is too narrow for a median barrier foundation slab. In such situations, the foundation may be required to be as narrow as the footprint of the median barrier itself which is 600 mm. Thus an anchorage footing that was narrow in width was designed to support the Manitoba Constrained-Width, Tall Wall median barrier.

Previous studies have used the design methodology that barrier footings should have the torsional strength to support the full overturning strength of the barrier in which they support [16, 33]. The torsion design load was calculated by multiplying the barrier's overturning moment capacity by the critical length of the barrier section,  $M_c$  and  $L_{CR}$  from the Yield Line analysis, respectively. Since the impact load can be distributed both upstream and downstream from impacts located on interior sections of the barrier, the design load of the interior section was divided by two.

Reinforced concrete footings were then designed using the torsion reinforcement methodology from the *Building Code Requirements for Structural Concrete (ACI 318-11)* [18]. For an interior section, a concrete footing 600 mm wide x 600 mm deep incorporating 20M stirrups at spacings of 400 mm and six 15M longitudinal bars was found to satisfy the required design strength. Due to the increased design load near end sections, the size of the footing for the end section had to be increased beyond the desired width of 600 mm. The resulting end section footing was 900 mm wide x 600 mm deep and incorporated 20M stirrups at spacings of 300 mm and eight 20M longitudinal bars. The stirrup spacings for both footings matched the transverse steel spacing for the corresponding barrier sections, so they could be tied together using either of the barrier anchorage options developed. The end section footing was designed for placement below the entire barrier end section that is 2.785 m long. The barrier is to be centred over the end footing.

## 10.3 TL-4 Median Barrier Configuration

MI also desired to have a MASH TL-4 version of the Manitoba Constrained-Width, Tall Wall median barrier. The TL-4 version was desired to use the same base width and traffic face geometry as the TL-5 version. This would allow the same forms to be used during fabrication of either barrier version by simply blocking out the top of the form to the desired height. A steel reinforcement configuration similar to the TL-5 median barrier was also desired to make the transition between the two barriers relatively easy. Thus, eight 10M bars was selected for use as the longitudinal steel reinforcement for the TL-4 median barrier, eliminating the top two bars from the TL-5 median barrier configuration.

---

Since the TL-4 version of the barrier was not going to be crash tested, the barrier was conservatively designed in terms of height and strength. Previous crash testing has shown that the old TL-4 standard height of 813 mm will not satisfy the new MASH TL-4 standards, and the 10,000 kg single-unit truck, designated as the 10000S vehicle, will roll over the top of the barrier [19, 20]. One MASH TL-4 crash test was conducted on a single-slope (11 degrees from vertical), concrete barrier that was 914 mm tall. The barrier contained the vehicle and satisfied all MASH evaluation criteria [21]. Therefore, 915 mm was selected as the height for the TL-4 version of the median barrier.

With limited MASH TL-4 crash tests conducted to date, the design load for a MASH TL-4 barrier has not yet been determined. Various studies have suggested a design load ranging between 355 kN and 445 kN for a MASH TL-4 barrier [10, 11]. To be conservative, a design load selected for the TL-4 median barrier developed in this project was 423 kN.

Yield Line analysis was used to calculate the design strength for various barrier configurations. Although a full optimisation analysis was not completed, multiple reinforcement configurations were analysed to determine a barrier configuration that satisfied the strength criteria while limiting the amount of steel reinforcement. The selected interior barrier configuration used 10M U-bar stirrups spaced at 400 mm and had a design strength of 423 kN, while the selected end section used 15M U-bars spaced at 300 mm and had a design strength of 431 kN. As desired, both barrier sections used eight 10M longitudinal bars. The required length of the end section adjacent to barrier discontinuities was 1.59 m.

The stirrups for the TL-4 barrier were developed as U-bars to match the stirrup designs for the bridge rail and TL-5 median barrier. However, the width of the TL-4 median barrier would allow the use of stirrups that are fully closed. Although they require more steel, closed-loop stirrups would provide more stiffness and stability during construction, especially during slipforming operations. Thus, either U-bar or closed-loop stirrups may be used within the TL-4 median barrier. Due to the similarity between the TL-4 and TL-5 barriers, the TL-4 median barrier may be anchored using either a foundation slab or footing as described in Sections 10.1 and 10.2.

#### **10.4 TL-5 Roadside Barrier Anchorage Options**

A vertical back roadside version of the Manitoba Constrained-Width, Tall Wall was desired for barrier installations requiring TL-5 capabilities. Roadside applications can be treated with the crash-tested TL-5 bridge rail configuration, except that the bridge deck would be replaced with alternative anchorage options. Anchorage options similar to the TL-5 median barrier were developed for the roadside configuration.

Anchoring of the roadside barrier to roadway slabs was designed with two options similar to the anchorage options of the median barrier to foundation slabs. Option 1 used 15M dowel bars, while Option 2 used a 15M U-bar. Both options require 200 mm of embedment and are spaced to match the U-bar stirrups of the barrier. The foundation slab should be an extension of the roadway slab, or tied directly to it, and contain steel reinforcement. The anchorage bars were different from the median anchorage bars only because the backside of the roadside barrier was vertical. The back side of the barrier should be offset at least 50 mm from the edge of the slab.

Footings were also designed to anchor the roadside barrier using the design methodology described in Section 10.2. The footing for interior barrier sections was 1,000 mm wide x 500 mm deep using 20M stirrups spaced at 400 mm and eight 15M longitudinal bars. The end section footing was 1,000 mm wide x 700 mm deep and used 20M stirrups spaced at 300 mm

---

and eight 20M longitudinal bars. For either section configuration, the barrier should be centred over the footing. The footing stirrups were designed with spacings to match the U-bars in the barrier, so all of the transverse steel within the barrier system could be tied together. Finally, the end section footing should be used directly below any barrier end sections for a distance of at least 2.785 m.

## **11 MANITOBA'S BARRIER DESIGNS**

Following the development of the Manitoba Constrained-Width, Tall Wall and the related transition barrier designs as well as, footing and anchorage options of interior and end sections, MI proceeded to create a set of standard design drawings for its use. Standard drawings were required for:

- 1) TL-5 at 1250 mm (median and roadside);
- 2) TL-5 at 1075 mm (median and roadside);
- 3) TL-4 at 915 mm (median and roadside);
- 4) transition from 1250 mm to 1075 mm (median and roadside);
- 5) transition from 1075 mm to 915 mm (median and roadside);
- 6) transition from 915 mm to 815 mm (median and roadside);
- 7) transition from median TL-5 at 1250 mm to back to back vertical back TL-5 at 1250 mm;
- 8) transition from median TL-4 at 915 mm to median F-shape at 815 mm
- 9) median at 1250 mm at overhead sign structure supports
- 10) transition from TL-4 to standard guardrail or crash attenuator (median and roadside)

The drawings for each configuration would require typical plan and elevation views along with cross sections for relevant positions through the barrier. In addition to the standard drawings required, details would also be needed to address the Department's practice of delineating its concrete median barriers. The Department currently uses 3M™ Linear Delineation System that is 152 mm wide and 876 mm long.

MI currently affixes the Linear Delineation System to the traffic face of its current F-shape barrier at a height of 800 mm to the top of the delineator. These devices suffer the ill effects of wide loads and snow clearing operations which often result in various levels of damage including removal. To address this ongoing damage, MI would modify the constant slope barrier such that a recess to accommodate the Linear Delineating System would be placed on the sloped face of the new barrier at a height of 550 mm to the bottom. This recess would provide some protection for the nuisance hits they are exposed to on a regular basis without creating any negative effects to the performance of the barrier itself.

### **11.1 Median Barrier Designs**

The first set of drawings created focused on the median environment commencing with the TL-5 at 1250 mm. This involved compiling interior and end section reinforcing details of the barrier and footings into representative plan, elevation and cross section views.

Creating a drawing that showed both interior and end section details on one drawing was not realistic given the differences in the two portions of the barrier. As a result, one sheet provided plan and elevation views of the interior section while a separate sheet was used for the end section; see Figures 3 and 4. For clarity purposes on the plan and elevation views, longitudinal reinforcing steel was omitted but was shown on cross section views; transverse reinforcing was also not shown on the plan view for this reason. The elevation view shows the transverse reinforcing as well as its relevant spacing on the interior and end sections drawings. The footing

---

beneath the barrier was not shown in either plan or elevation views to minimise clutter and ensure clarity of design.

The cross section view of the barrier showed the transverse stirrup and longitudinal rebar positions as well as a detail of the recess required to accommodate the Linear Delineation System. Three cross section views of footing options were also developed for the barrier based on recommendations by MwRSF. The cross sections of the footings also included transverse stirrups and longitudinal rebar as well as two options to anchor the barrier onto the footing options; this resulted in six different footing cross sections. See Figures 5 and 6.

The footing options were: 1) 280 mm deep by 2000 mm wide; 2) 600 mm deep by 600 mm wide; and 3) 600 mm deep by 1000 mm wide. Each option had minimum dimensions for depth and width, and allowed for design engineers to be selective of the footing based on interior versus end section as well as any local site restrictions such as underground utility vault with shallow cover.

Finally, a sheet that provided reinforcing steel drawings was developed to include all individual shaped bars. Details for the fabrication of various bent bars followed the Reinforcing Steel Institute of Canada Reinforcing Steel Manual of Standard Practice [24]. Each bar was identified using the Department's standard structural numbering convention. Many of these reinforcing steel drawings would be used throughout the series of over 15 required drawings identified and it was necessary to establish an effective numbering convention for this new barrier system.

With the initial Manitoba Constrained-Width Tall Wall drawing(s) completed, similar drawings were developed for median cross sections of standard TL-5 barrier at 1075 mm and TL-4 barrier at 915 mm. MASH research has suggested 1067 mm (42 inches) is sufficient for successful TL-5 crash testing. MI opted to increase this height to 1075. Similarly, TL-4 MASH research has indicated that 914 mm (36 inches) was required for a successful test but this was rounded up to 915 mm. Reasonable tolerances in construction will likely result in barrier heights of  $\pm 5$  mm which will help maintain minimum required heights.

Standard guardrail components such as thrie beam and w beam cannot be attached to the original TL-5 median barrier height of 1250 mm and provide a successful transition that would be compliant to MASH TL-3 criteria let alone TL-5 criteria. This required MI to develop and accept a design that would be required to transition to a TL-3 system at its upstream end and would not be TL-5 compliant for the entire barrier installation.

To ensure the Manitoba Constrained-Width Tall Wall TL-5 barrier was used effectively where the taller height of 1250 mm was required, it was necessary to establish length of need parameters for the barrier. This would provide design engineers the guidance necessary to determine where TL-5 barriers incorporating headlight glare would be satisfied. Upstream of this point, it would be acceptable that TL-5 barriers would not be possible and suitable barriers of lower performance levels would be provided.

Crash attenuators and, as mentioned previously, semi rigid barriers are often used to mitigate the upstream ends of rigid barriers to approaching errant vehicles. Rigid barriers that project above the top of semi rigid barriers pose additional problems to impacting vehicles by creating a snag point. To address the height differential between top of the TL-3 barriers such as thrie beam and the top of the Manitoba Constrained-Width Tall Wall barrier that has a height of 1250 mm, the top of the barrier needed to taper down in height to prevent vehicle snag. Changes in barrier heights must be transitioned gradually. Barrier height changes have previously been

---

designed and successfully crash tested with vertical slopes up as steep as 5:1 [25]. Thus, all barrier height transitions should be transitioned at vertical slopes of 5H:1V or flatter.

One option to consider would be to develop a transition from 1250 mm to 815 mm but this would not provide for transitions from 1075 mm or 915 mm without redesign of transitions on an individual basis. Manitoba opted to develop transitions that would allow for transitions in height from 1250 mm to 1075 mm, 1075 mm to 915 mm and from 915 mm to 815 mm. This would provide the design engineer with the most flexibility in their design selections for their projects.

If a project had several barrier heights away from the upstream end, it would be possible to design and construct the various design height barriers along with the necessary transitions with a variety of options between the different heights. If it was necessary to transition directly from a barrier of 1250 mm in height to 815 mm, the various transition options could be 'joined' together to form one continuous transition.

Using the methodology employed with the development of the three design heights (1250 mm, 1075 mm and 915 mm), MI created standard transition drawings that contained relevant information related to plan, elevation and cross sections views. Essential footing and reinforcing details were provided consistent with the information provided in the three 'standard' designs.

## **11.2 Roadside Barrier Designs**

With the median barrier designs completed of the Manitoba Constrained-Width Tall Wall, the roadside design options needed to be completed. Once again, the first set of drawings created focused on the TL-5 at 1250 mm. This involved compiling interior and end section reinforcing details of the barrier and footings into representative plan, elevation and cross section views that were effective for roadside barriers.

As was identified by MwRSF in their research work, the roadside design with a vertical back could be widened at its top without affecting the maximum depth requirement of 600 mm. The designed and crash tested barrier with its vertical back was modified slightly at its anchorage points to reflect the absence of a bridge deck.

With the lessons learned from the median design options, similar drawing details were created for the tallest barrier at 1250 mm; see Figures 7 and 8. Roadside barrier design drawings subsequently followed for 1075 mm and 915 mm barrier heights.

Cross section views of footing options were also developed for the barrier based on recommendations by MwRSF. The cross sections of the footings also included transverse stirrups and longitudinal rebar as well as options to anchor the barrier onto the footing options; see Figures 9 and 10.

The footing allowed for design engineers to be selective of the footing based on interior versus end section as well as any local site restrictions such as underground utility vault with shallow cover.

With the initial three Manitoba Constrained-Width Tall Wall roadside barrier drawing(s) completed, similar drawings were developed for roadside cross sections of standard TL-5 barrier at 1075 mm and TL-4 barrier at 915 mm. Similar investigations and considerations were used in establishing barrier heights, transitions and end treatments for roadside barriers as for the median barriers.

---

## 12 SUMMARY, CONCLUSIONS, AND RECOMMENDATIONS

### 12.1 Summary and Conclusions

The objective of this project was to develop a constant slope concrete barrier system that was 1,250 mm tall to satisfy MASH TL-5 safety standards. Barrier configurations of the Manitoba Constrained-Width, Tall Wall were developed for median, roadside, and bridge rail applications. The new barrier system maintained a narrow footprint that was 600 mm wide for median installations while providing increased strength and vehicle stability during impact events as well as reducing headlight glare from opposing traffic.

Because the vertical back bridge rail configuration would have a reduced width and was supported by a cantilevered bridge deck, it was identified as the most critical configuration. Thus, the bridge rail was developed first and subjected to full-scale crash testing. The bridge rail width and reinforcement configuration was optimised to resist the design load and minimise the amount of steel reinforcement in the barrier. Optimised interior and end section configurations were selected and recommended for evaluation through full-scale crash testing.

The test installation was 45.72 m long with a height of 1,250 mm, a top width of 250 mm, and a base width of 450 mm. The upstream half of the bridge rail was installed on a simulated bridge deck that was 280 mm thick with an overhang distance of 1,300 mm, while the downstream half was anchored to the concrete tarmac to provide runout length. At the mid-span of the simulated bridge deck, open gaps were placed in both the bridge rail and deck to simulate an expansion-contraction joint. End section reinforcement was used in the bridge rail and deck on both sides of the open joint. A steel cover plate was secured to the rail joint and used to shield vehicles from snagging on the exposed ends of the bridge rail adjacent to the joint.

One full-scale crash test was performed on the barrier according to MASH test designation no. 5-12. The impact point was selected to provide maximum loading to the bridge rail at the critical location, which was adjacent to the barrier joint. The vehicle was contained and redirected with minimal damage to the barrier. Minor cracks were found in the barrier and the bridge deck, and a small area measuring less than 50 mm deep fractured away from the top of the bridge rail due to contact with the trailer's front-bottom corner. The bridge rail experienced no permanent deflections. The small car and pickup truck tests required by MASH TL-5 were not considered critical and, thus, not conducted due to prior successful small car and pickup truck impacts into similar rigid barriers. The barrier system was therefore deemed crashworthy according to MASH TL-5 safety standards.

After the successful crash testing of the Manitoba Constrained-Width, Tall Wall bridge rail, median and roadside configurations were also developed. The TL-5 median barrier used a 600 mm wide base and the same constant slope face geometry as the bridge rail. Barrier configurations with optimised steel reinforcement were developed for both the interior and end sections of the TL-5 median barrier. A TL-4 version of the median barrier was also developed with the same width and slope as the median barrier so that the same forms could be used to install either barrier configuration. Anchorage options were then provided to support the median barrier with a reinforced concrete foundation slab or independent footings. Details were also provided for a TL-5 roadside barrier, which was identical to the bridge rail, anchored with either a foundation slab or independent footing.

---

Barrier system standard design drawings were developed by Manitoba Infrastructure for a number of existing and future geometric conditions. These included: 1) TL-5 at 1250 mm and 1075 mm barriers for both median and roadside; 2) TL-4 at 915 mm barriers for median and roadside; 3) transitions between several different heights of median and roadside configurations; 4) transitions to provide TL-3 end treatment at the upstream end for both median and roadside configurations; 5) transitions from median TL-5 at 1250 to dual (back to back) vertical back barriers; 6) transition from constant slope to F-shape at 915 for both median and roadside. Maximum vertical tapers do not exceed 5H:1V to prevent vehicle snag.

## 12.2 Installation Recommendations

MI commonly uses a Linear Delineation System by 3M on its concrete barriers and desire to create longitudinal recesses in the concrete barriers for the placement of roadway delineators. These recesses were not implemented into the test article due to ease of construction. The small reduction in barrier cross section from the 20 mm indentation should not affect barrier strength. The recesses extend longitudinally along the barrier, so vehicle snag should not occur. Therefore, the inclusion of these recesses is not thought to negatively affect the performance of the Manitoba Constrained-Width, Tall Wall barrier.

The 168 mm gap placed in the bridge rail was selected to represent a typical joint opening and to align the transverse reinforcement spacings of the barrier and deck segments without having an odd spacing or extra bar. Joint openings larger than that used in test no. MAN-1 are likely to occur in real-world installations. Basic bending calculations indicate the cover plate should be sufficient to shield gap lengths up to 300 mm without it negatively affecting system performance. However, the only sure way to evaluate the maximum gap length is through full-scale crash testing. If gaps larger than 300 mm are necessary due to an inability to cast barrier segments directly to expansion joint hardware in the deck, it is recommended to cast cantilevered extension sections of the barrier over the expansion joint hardware to reduce the gap length. The cantilevered extensions of the barrier should have the same geometry as the adjacent barrier, only the bottom 200 mm of the barrier should be removed. The length of the cantilevered extensions should be held to a minimum while reducing the maximum gap length to less than 300 mm. Barrier reinforcement should be continued into the cantilevered extensions to ensure proper strength. If necessary, the length of the steel cover plate should be increased such that it covers at least 100 mm of the full barrier cross section on both sides of the joint.

The upstream edge on the front of the steel cover plate was chamfered to prevent vehicle snag during impacts. If the design is used in an installation where reverse directions are possible, then both sides on the front of the cover plate should be chamfered. If it is used in a median barrier, then both the front and back of the steel cover plate need to be chamfered. All chamfers should be 6 mm x 6 mm.

The working width of the Manitoba Constrained-Width, Tall Wall barrier was found to be 949 mm as measured from high-speed video during test no. MAN-1. Working width is defined as the distance between the front of the barrier to the farthest lateral extent of the vehicle (or barrier component), while the zone of intrusion represents the area above and behind the barrier that a vehicle component may occupy during redirection. Since the top of the Manitoba Constrained-Width, Tall Wall is offset 200 mm from the front toe, the zone of intrusion for the barrier measures 749 mm laterally from the top front corner of the barrier and extends upward the full height of a tractor trailer vehicle, or approximately 4.1 m.

---

## References

1. *Manual for Assessing Safety Hardware (MASH)*, American Association of State Highway and Transportation Officials (AASHTO), Washington, D.C., 2009.
2. Beason, W.L., Ross, H.E., Perera, H.S., Campise, W.L., and Bullard, D.L., Development of a Single-Slope Concrete Median Barrier, Report 9429CDK-1, Texas State Department of Highways and Public Transportation, Texas Transportation Institute, College Station, TX, June 1989.
3. Beason, W.L., Ross, H.E., Perera, H.S., and Marek, M., *Single-Slope Concrete Median Barrier*, Transportation Research Record No. 1302, Transportation Research Board, National Research Council, Washington, D.C., 1991.
4. Jewell, J.R., *Vehicle Crash Tests of a Slip-Formed, Single Slope, Concrete Median Barrier with Integral Concrete Glare Screen*, California Department of Transportation, Division of New Technology, Materials and Research, 1997.
5. *Glare Screen Guidelines*, National Cooperative Highway Research Program (NCHRP), Synthesis of Highway Practice 66, Transportation Research Board, Washington D.C., 1979.
6. Rosenbaugh, S.K., Schmidt, J.D., Faller, R.K. and Regier, E.M. *Development of the Manitoba Constrained-Width, Tall Wall Barrier* Research Report No. TRP-03-256-16, Midwest Roadside Safety Facility, University of Nebraska-Lincoln, Lincoln, NE, September 26, 2016.
7. Ross, H.E., Sicking, D.L., Zimmer, R.A., and Michie, J.D., *Recommended Procedures for the Safety Performance Evaluation of Highway Features*, National Cooperative Research Program (NCHRP) Report 350, Transportation Research Board, Washington, D.C., 1993.
8. *Guide Specifications for Bridge Railings*, American Association of State Highway and Transportation Officials (AASHTO), Washington, DC, 1989.
9. AASHTO LRFD Bridge Design Specifications -Customary U.S. Units - 2012, American Association of State Highway and Transportation Officials (AASHTO), Washington, D.C., 2012. September 23, 2016 MwRSF Report No. TRP-03-356-16
10. *Roadside Design Guide*, 4th Edition 2011, American Association of State and Highway Transportation Officials (AASHTO), Washington D.C., 2011.
11. Williams, W.F., Bligh, R.P., and Menges, W.L., *MASH Test 4-11 of the TxDOT Single Slope Bridge Rail (Type SSTR) on Pan-Formed Bridge Deck*, Final Report to the Texas Department of Transportation, Report No. FHWA/TX-11/9-1002-3, Texas Transportation Institute, Texas A&M University, College Station, Texas, March 2011.
12. Schmidt, J.D., Faller, R.K., Lechtenberg, K.A., Sicking, D.L., and Reid, J.D., *Development and Testing of a New Vertical-Faced Temporary Concrete Barrier for use on Composite Panel Bridge Decks*, Final Report to the Kansas Department of Transportation, MwRSF Research Report No. TRP-03-220-09, Midwest Roadside Safety Facility, University of Nebraska-Lincoln, Lincoln, Nebraska, October 13, 2009.



- 
13. Polivka, K.A., Faller, R.K., Sicking, D.L., Rohde, J.R., Bielenberg, R.W., Reid, J.D., and Coon, B.A., *Performance Evaluation of the Permanent New Jersey Safety Shape Barrier – Update to NCHRP 350 Test No. 4-10 (2214NJ-1)*, Final Report to the National Cooperative Highway Research Program, MwRSF Research Report No. TRP-03-177-06, Midwest Roadside Safety Facility, University of Nebraska-Lincoln, Lincoln, Nebraska, October 13, 2006.
14. Bligh, R.P., Arrington, D.R., Sheikh, N.M., Silvestri, C., and Menges, W.L., *Development of a MASH TL-4 Median Barrier Gate*, Final Report to the Texas Department of Transportation, Report No. FHWA/TX-11/9-1002-2, Texas A&M University, College Station, Texas, Texas Transportation Institute, June 2011.
15. Bullard, D.L., Bligh, R.P., Menges, W.L., and Haug, R.R., *Volume I: Evaluation of Existing Roadside Safety Hardware Using Updated Criteria – Technical Report*, National Cooperative Highway Research Program Web Only Document 157, Transportation Research Board, Washington, D.C., 2010.
16. Rosenbaugh, S.K., Sicking, D.L., and Faller, R.K., *Development of a TL-5 Vertical Faced Concrete Median Barrier Incorporating Head Ejection Criteria*, Research Report No. TRP-03-194-07, Midwest Roadside Safety Facility, University of Nebraska-Lincoln, Lincoln, NE, December 10, 2007.
17. Rosenbaugh, S.K., Faller, R.K., Hascall, J.A., Allison, E.A., Bielenberg, R.W., Rohde, J.R., Sicking, D.L., Polivka, K.A., Reid, J.D., *Development of a Stand-Alone Concrete Bridge Pier Protection System*, Research Report No. TRP-03-190-08, Midwest Roadside Safety Facility, University of Nebraska-Lincoln, Lincoln, Nebraska, April 18, 2018.
18. *Building Code Requirements for Structural Concrete (ACI 318-11) and Commentary (ACI 318R-11): An ACI Standard*, Reported by ACI Committee 318, American Concrete Institute, Farmington Hills, MI, 2011.
19. Polivka, K.A., Faller, R.K., Sicking, D.L., Rohde, J.R., Bielenberg, R.W., Reid, J.D., and Coon, B.A., *Performance Evaluation of the Permanent New Jersey Safety Shape Barrier – Update to NCHRP 350 Test No. 4-12 (2214NJ-2)*, Final Report to the National Cooperative Highway Research Program, MwRSF Research Report No. TRP-03-178-06, Midwest Roadside Safety Facility, University of Nebraska-Lincoln, Lincoln, Nebraska, October 13, 2006.
20. Bullard, D.L., Bligh, R.P., and Menges, W.L., *MASH08 TL-4 Testing and Evaluation of the New Jersey Safety Shape Bridge Rail*, Preliminary Test Report to the National Cooperative Highway Research Program, Test Report No. RF 476460-1b, Texas Transportation Institute, Texas A&M University, College Station, Texas, November 2008.
21. Sheikh, N.M., Bligh, R.P., and Menges, W.L., *Determination of Minimum Height and Lateral Design Load for MASH Test Level 4 Bridge Rails*, Cooperative Research Program Test Report No. 9-1002-5, Texas Transportation Institute, Texas A&M University, College Station, Texas, October 2011.
22. *Design Guidelines for Test Level 3 (TL-3) through Test Level 5 (TL-5) of Roadside Barrier Systems Placed on MSE Retaining Walls*, Combined Quarterly Progress Report August 2012 – December 2012, NCHRP Project 22-20(2), TTI Project No. 478130, December 2012.

---

23. Rosenbaugh, S.K., Faller, R.K., Bielenberg, R.W., Sicking, D.L., Reid, J.D., and Tadros, M.K., *Phase I Development of an Aesthetic, Precast Concrete Bridge Rail*, Research Report No. TRP-03-239-12, Midwest Roadside Safety Facility, University of Nebraska-Lincoln, Lincoln, Nebraska, February 13, 2012.

24. Reinforcing Steel - Manual of Standard Practice, Fourth Canadian Edition 2004, Reinforcing Steel Institute of Canada (RSIC/IAAC), Richmond Hill ON, 2004.

25. Wiebelhaus, M.J., Terpsma, R.J., Lechtenberg, K.A., Reid, J.D., Faller, R.K., Bielenberg, R.W., Rhode, J.R., and Sicking, D.L., *Development of a Temporary Concrete Barrier to Permanent Concrete Median Barrier Approach Transition*, Research Report No. TRP-03-208-10, Midwest Roadside Safety Facility, University of Nebraska-Lincoln, Lincoln, Nebraska, July 15, 2010.

## Tables and Figures

Table 1: MASH crash test conditions for longitudinal barriers

Test Level	Test Designation	Impact Conditions		
		Vehicle	Nominal Speed (km/h)	Nominal Angle, $\theta$ (deg)
1	1-10	1100C	50	25
	1-11	2270P	50	25
2	2-10	1100C	70	25
	2-11	2270P	70	25
3 (Basic Level)	3-10	1100C	100	25
	3-11	2270P	100	25
4	4-10	1100C	100	25
	4-11	2270P	100	25
	4-12	10000S	90	15
5	5-10	1100C	100	25
	5-11	2270P	100	25
	5-12	36000V	80	15
6	6-10	1100C	100	25
	6-11	2270P	100	25
	6-12	36000T	80	15

Figure 1: General configuration of Manitoba Constrained-Width Tall Wall bridge rail

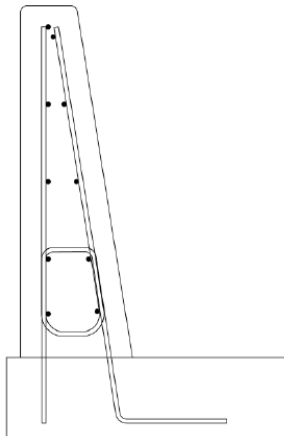

Figure 2: Test installation photographs



Figure 3: plan and elevation views of the median barrier interior section

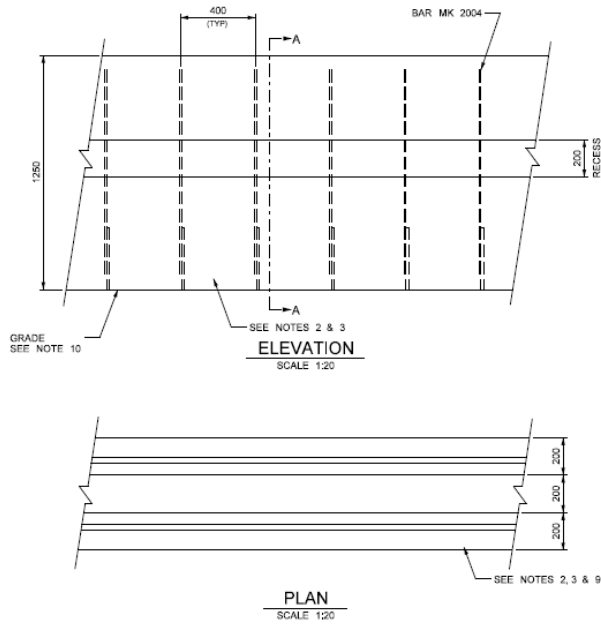

Figure 4: plan and elevation views of the median barrier end section

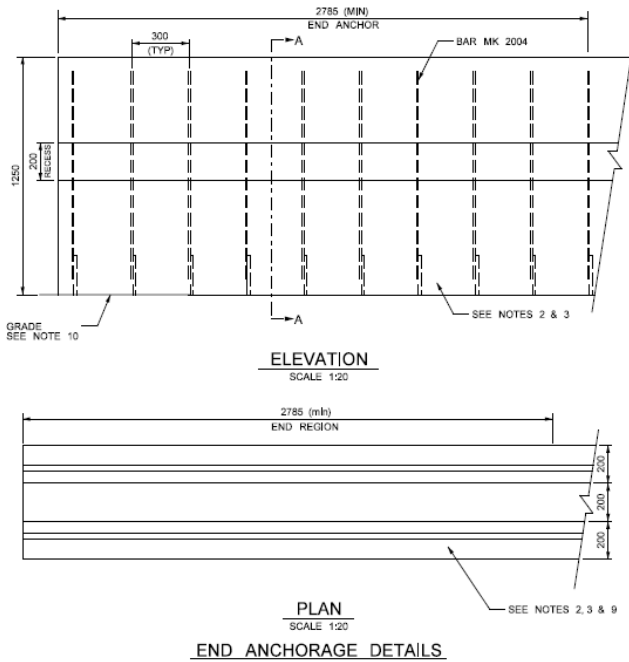

Figure 5: Cross section view of the median barrier:

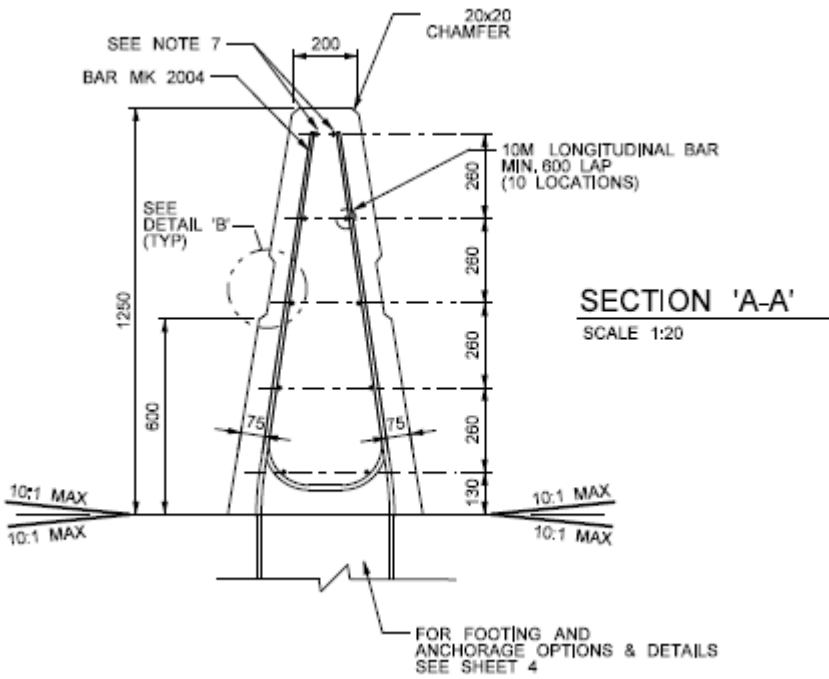

Figure 6: Cross section views of median barrier footing options

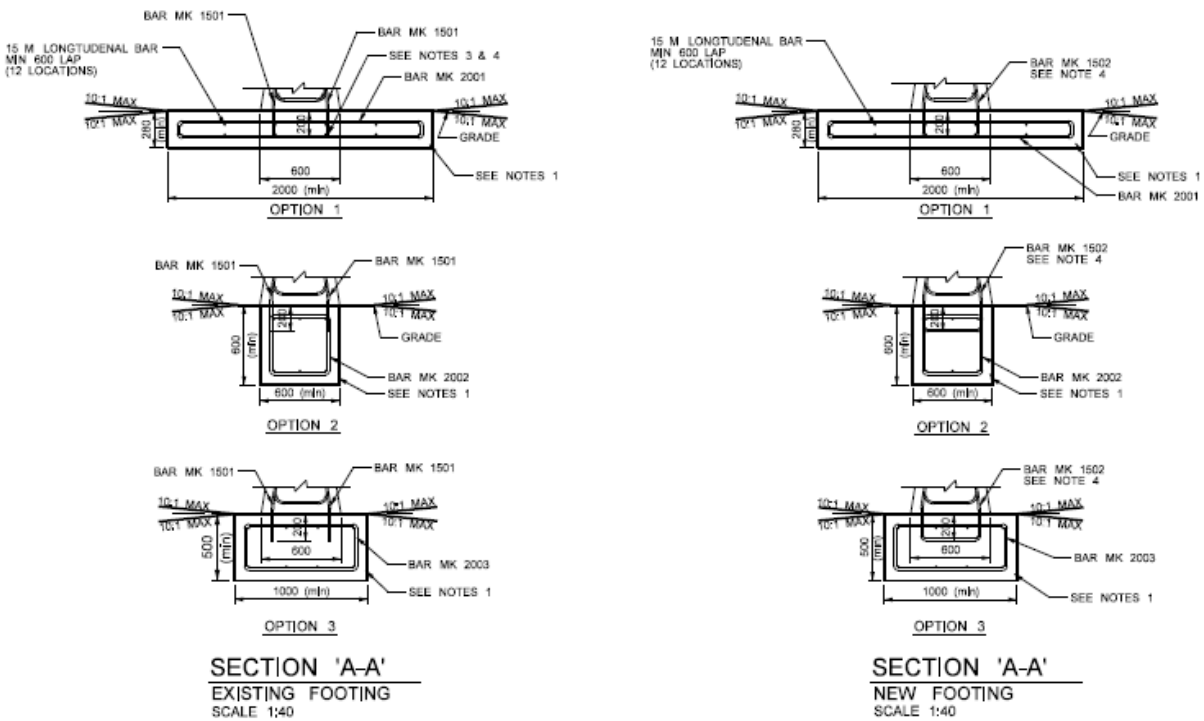

Figure 7: plan and elevation views of the roadside barrier interior section

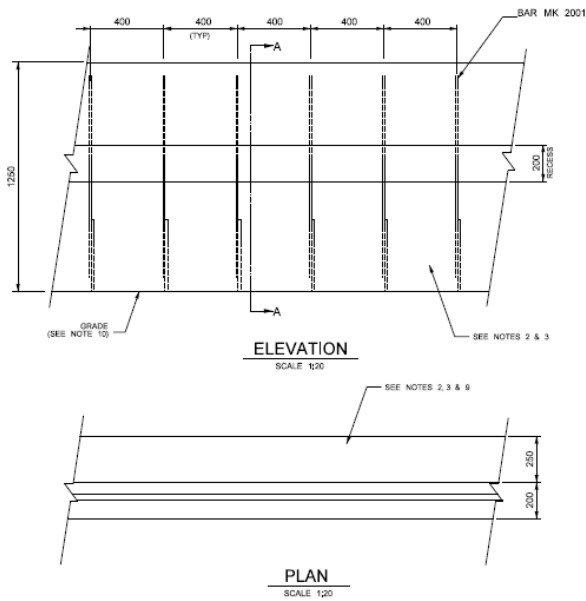

Figure 8: plan and elevation views of the roadside barrier end section

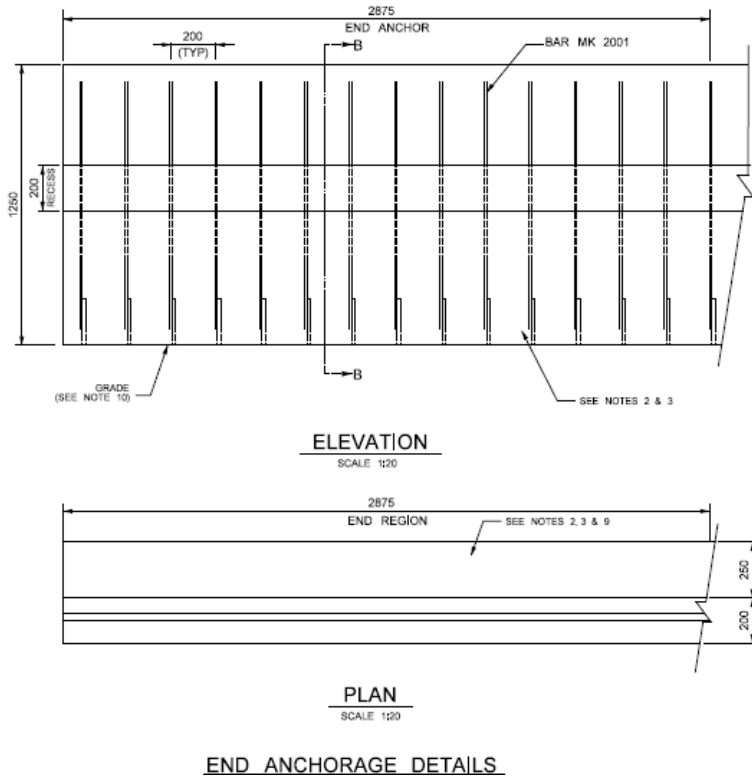

Figure 9: Cross section view of the interior section roadside barrier, footings and anchorage options

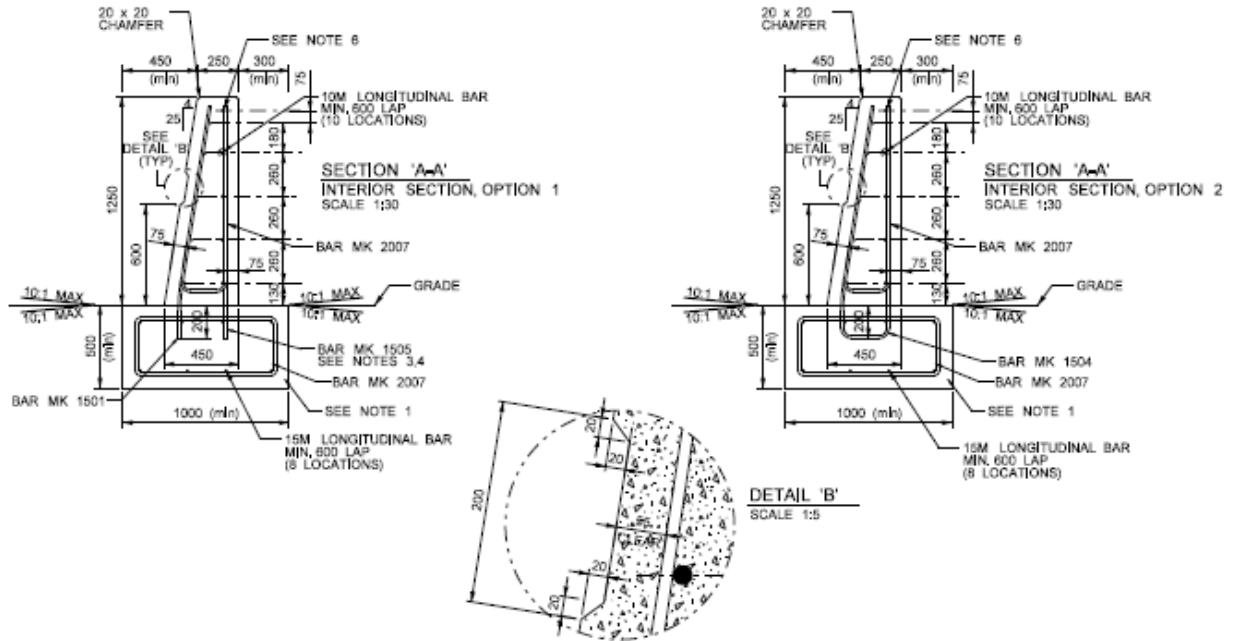

Figure 10: Cross section views of the end section roadside barrier, footings and anchorage options

