

University of Nebraska - Lincoln

DigitalCommons@University of Nebraska - Lincoln

Nebraska Tractor Tests

Tractor Test and Power Museum, The Lester F.
Larsen

January 2000

Test 1769: AGCO LT70 Diesel

Nebraska Tractor Test Laboratory Submitted by Larsen Museum

Follow this and additional works at: <https://digitalcommons.unl.edu/tractormuseumlit>



Part of the [Applied Mechanics Commons](#)

Submitted by Larsen Museum, Nebraska Tractor Test Laboratory, "Test 1769: AGCO LT70 Diesel" (2000).
Nebraska Tractor Tests. 123.

<https://digitalcommons.unl.edu/tractormuseumlit/123>

This Article is brought to you for free and open access by the Tractor Test and Power Museum, The Lester F. Larsen at DigitalCommons@University of Nebraska - Lincoln. It has been accepted for inclusion in Nebraska Tractor Tests by an authorized administrator of DigitalCommons@University of Nebraska - Lincoln.

NEBRASKA TRACTOR TEST 1769

WHITE 6410 DIESEL

ALSO AGCO ALLIS 8745 DIESEL(CUMMINS ENGINE)

ALSO AGCO LT70 DIESEL

12 SPEED

POWER TAKE-OFF PERFORMANCE

Power HP (kW)	Crank shaft speed rpm	Gal/hr (l/h)	lb/hp.hr (kg/kW.h)	Hp.hr/gal (kW.h/l)	Mean Atmospheric Conditions
MAXIMUM POWER AND FUEL CONSUMPTION					
Rated Engine Speed (PTO speed 1100 rpm)					
70.40 (52.50)	2200	4.87 (18.43)	0.489 (0.297)	14.46 (2.85)	
Standard Power Take-off Speed - (1000 rpm)					
74.89 (55.85)	2000	4.76 (18.01)	0.449 (0.273)	15.74 (3.10)	
Maximum Power (2 hours)					
75.23 (56.10)	1901	4.63 (17.55)	0.435 (0.265)	16.23 (3.20)	

VARYING POWER AND FUEL CONSUMPTION

70.40 (52.50)	2200	4.87 (18.43)	0.489 (0.297)	14.46 (2.85)	Air temperature
60.94 (45.44)	2247	4.37 (16.55)	0.507 (0.308)	13.94 (2.75)	76°F (24°C)
46.14 (34.41)	2278	3.74 (14.14)	0.572 (0.348)	12.35 (2.43)	Relative humidity
31.39 (23.41)	2310	3.01 (11.39)	0.679 (0.413)	10.42 (2.05)	28%
15.91 (11.86)	2346	2.38 (9.01)	1.056 (0.642)	6.69 (1.32)	Barometer
1.13 (0.84)	2377	1.74 (6.59)	10.876 (6.615)	0.65 (0.13)	29.12" Hg (98.62 kPa)

Maximum Torque 235 lb.-ft. (319 Nm) at 1401 rpm
 Maximum Torque Rise - 39.7%
 Torque rise at 1802 rpm - 27%

TRACTOR SOUND LEVEL WITH CAB

	dB(A)
At no load in 6th(3LH) gear	82.3
Bystander	--

TIRES AND WEIGHT

Rear Tires No., size, ply & psi (kPa)
Front Tires No., size, ply & psi (kPa)
Height of Drawbar
Static Weight with operator Rear
 Front
 Total

Tested Without Ballast

Two 18.4R34; **, 16 (110)
 Two 10.00-16; 8; 32 (220)
 17.0 in (430 mm)
 5085 lb (2307 kg)
 3065 lb (1390 kg)
 8150 lb (3697 kg)

Location of Test: Nebraska Tractor Test Laboratory, University of Nebraska, Lincoln Nebraska 68583-0832

Dates of Test: March 16-17, 2000

Manufacturer: AGCO Corporation, Duluth Georgia 30096

FUEL, OIL and TIME: Fuel No. 2 Diesel Specific gravity converted to 60°/60° F (15°/15°C) 0.8487 Fuel weight 7.067 lbs/gal (0.847 kg/l) Oil SAE 15W40 API service classification CE/CF-4 Transmission and hydraulic lubricant AGCO Power Fluid 821 XL fluid Total time engine was operated 10.0 hours

ENGINE: Make Cummins Diesel **Type** four cylinder vertical with turbocharger **Serial No.** 21299443 **Crankshaft** lengthwise **Rated engine speed** 2200 **Bore and stroke** 4.016" x 4.724" (102.0 mm x 120.0 mm) **Compression ratio** 17.0 to 1 **Displacement** 239 cu in (3920 ml) **Starting system** 12 volt **Lubrication** pressure **Air cleaner** one paper element and one polyester felt element **Oil filter** one full flow cartridge **Oil cooler** engine coolant heat exchanger for crankcase oil **Fuel filter** one paper element and water separator **Muffler** underhood **Exhaust** vertical **Cooling medium temperature control** one thermostat

ENGINE OPERATING PARAMETERS: Fuel rate: 32.7 - 36.1 lb/h (14.8 - 16.4 kg/h) **High idle:** 2350 - 2450 rpm **Turbo boost:** nominal 20.0 - 23.5 psi (138 - 162 kPa) as measured 21.8 psi (150 kPa)

CHASSIS: Type standard **Serial No.** G08191 **Tread width** rear 56.1" (1425 mm) to 83.9" (2130 mm) front 54.0" (1372 mm) to 78.0" (1981 mm) **Wheelbase** 96.0" (2438 mm) **Hydraulic control system** direct engine drive **Transmission** selective gear fixed ratio **Nominal travel speeds mph (km/h)** first 1.44 (2.32) second 1.73 (2.79) third 2.16 (3.48) fourth 2.58 (4.16) fifth 3.96 (6.38) sixth 4.77 (7.68) seventh 5.90 (9.49) eighth 7.10 (11.42) ninth 8.85 (14.24) tenth 10.64 (17.13) eleventh 16.22 (26.10) twelfth 19.51 (31.40) reverse 2.16 (3.48), 2.60 (4.19), 8.85 (14.24), 10.64 (17.13) **Clutch** multiple wet disc operated by foot pedal **Brakes** single wet disc hydraulically operated by two foot pedals which can be locked together **Steering** hydrostatic **Power take-off** 540 rpm at 1902 engine rpm or 1000 rpm at 2000 engine rpm **Unladen tractor mass** 7975 lb (3617 kg)

THREE POINT HITCH PERFORMANCE (OECD Static Test)

CATEGORY: II

Quick Attach: None

Maximum Force Exerted Through Whole Range:	3348 lbs (14.9 kN)	High lift Option 5733 lbs (25.5 kN)
i) Opening pressure of relief valve:	NA	Combined flow
Sustained pressure of the open relief valve:	3010 psi (207 bar)	3030 psi (209 bar)
ii) Pump delivery rate at minimum pressure and rated engine speed:	10.6 GPM (40.1 l/min)	18.5 GPM (70.0 l/min)
iii) Pump delivery rate at maximum hydraulic power:	7.6 GPM (28.8 l/min)	14.9 GPM (56.4 l/min)
Delivery pressure:	2870 psi (198 bar)	2830 psi (195 bar)
Power:	12.7 HP (9.5 kW)	24.6 HP (18.3 kW)

THREE POINT HITCH PERFORMANCE

Observed Maximum Pressure psi. (bar)	3320 (229)
Location:	lift cylinder
Hydraulic oil temperature: °F (°C)	158 (70)
Location:	hydraulic sump
Category:	II
Quick attach:	none

SAE Static Test System pressure 2990 psi (206 Bar)

Hitch point distance to ground level in. (mm)	9.4 (239)	14.9 (378)	21.9 (556)	28.9 (734)	37.4 (950)
Lift force on frame lb	4113	4500	4631	4613	4743
" " " " " " (kN)	(18.3)	(20.0)	(20.6)	(20.5)	(21.1)

High lift Option

SAE Static Test System pressure 2990 psi (206 Bar)

Hitch point distance to ground level in. (mm)	7.7 (196)	14.7 (373)	21.7 (551)	28.7 (729)	35.7 (907)
Lift force on frame lb	6894	7421	7565	7488	7425
" " " " " " (kN)	(30.7)	(33.0)	(33.7)	(33.3)	(33.0)

	High lift option			
	inch	mm	inch	mm
A	31.0	788	34.0	864
B	12.2	310	12.2	310
C	15.1	384	15.1	384
D	9.4	240	9.4	240
E	7.6	192	7.6	192
F	8.3	210	11.0	280
G	31.3	795	31.3	795
H	1.3	32	1.3	32
I	5.7	145	5.7	145
J	23.0	585	20.3	515
K	26.3	667	24.5	622
L	38.3	972	41.3	1048
M	21.8	552	24.8	629
N	39.0	991	42.0	1067
O	7.9	200	7.9	200
P	47.0	1195	44.3	1125
Q	33.9	860	33.1	841
R	31.6	802	32.1	815

HITCH DIMENSIONS AS TESTED - NO LOAD

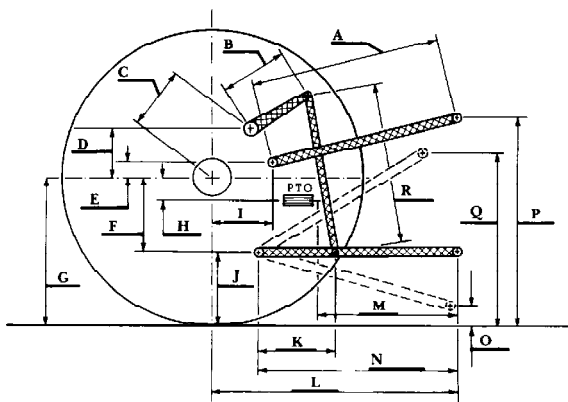

REPAIRS AND ADJUSTMENTS: No repairs or adjustments

REMARKS: All test results were determined from observed data obtained in accordance with official OECD, SAE and Nebraska test procedures. For the maximum power tests, the fuel temperature at the injection pump was maintained at 141°F (61°C).

Report reissued: Supplemental permits for AGCO Allis 8745 Diesel (Cummins engine) and AGCO LT 70 Diesel, November, 2001.

We, the undersigned, certify that this is a true and correct report of official Tractor Test No. **1769**, November 6, 2001.

Leonard L. Bashford
Director

M.F. Kocher
V.I. Adamchuk
G.J. Hoffman
Board of Tractor Test Engineers



White 6410 Diesel