

University of Nebraska - Lincoln

DigitalCommons@University of Nebraska - Lincoln

---

Robert Katz Publications

Research Papers in Physics and Astronomy

---

1958

## ***Physics*, Chapter 39: Optical Instruments**

Henry Semat

*City College of New York*

Robert Katz

*University of Nebraska-Lincoln*, rkatz2@unl.edu

Follow this and additional works at: <https://digitalcommons.unl.edu/physicskatz>



Part of the [Physics Commons](#)

---

Semat, Henry and Katz, Robert, "*Physics*, Chapter 39: Optical Instruments" (1958). *Robert Katz Publications*. 179.

<https://digitalcommons.unl.edu/physicskatz/179>

This Article is brought to you for free and open access by the Research Papers in Physics and Astronomy at DigitalCommons@University of Nebraska - Lincoln. It has been accepted for inclusion in Robert Katz Publications by an authorized administrator of DigitalCommons@University of Nebraska - Lincoln.

# 39

## Optical Instruments

### 39-1 The Camera

The photographic camera uses a converging lens to form a real, inverted image of an object. The image is focused on a film or plate which is coated with an emulsion containing silver bromide crystals. When a few incident quanta of light are absorbed in a grain of emulsion, the grain becomes activated and developable, and when the plate is developed, the bromine is removed from each activated grain, leaving a clump of silver behind. When the plate is "fixed," the remaining emulsion is removed from the plate, so that the image is made permanent. In most cameras the converging lens consists of several elements designed and arranged to reduce objectionable aberrations to a minimum. In general, the lens is designed for a particular arrangement of image and object, as in a camera, where the object is usually much farther from the lens than is the image. A camera lens designed to minimize aberrations for an infinitely distant object may not be well corrected for "close-ups."

A lens system used in some fairly good cameras is shown in Figure 39-1. Two achromats are spaced the proper distance apart, and an adjustable *iris* diaphragm is placed between them. A *shutter* is usually placed near the diaphragm to admit light for a preset time interval. The distance between the lens and film is adjusted when the camera is focused on the object to be photographed. In some box or "fixed-focus" cameras, there is no way to move the lens with respect to the film. The lens used in such a camera has a short focal length, and, as long as the object is at a distance greater

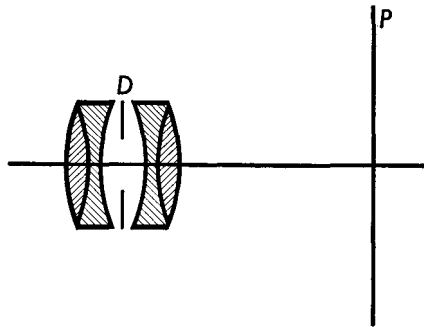

Fig. 39-1 A camera lens system.

than about 6 ft from the lens, its image will be focused close enough to the principal focus so that the blurring is not severe. The designer of the box camera must be certain that all objects from about 6 ft to infinity are all pleasantly and equally blurred.

The number of developable grains of emulsion per unit area, which determines the blackness of the developed film, depends upon the number of light quanta which strike a unit area of the emulsion. This number is related to the product  $E \Delta t$ , where  $E$  is the illuminance, and  $\Delta t$  is the exposure time. Films are rated in arbitrary ways, as to their speed, but, in general, the higher the speed, the smaller the number of incident quanta per unit area required to produce a developable image. For convenience let us assume as a first approximation, that this relationship is a simple one, such as

$$S = \frac{\alpha}{E \Delta t},$$

where  $S$  is the speed of the film, and  $\alpha$  is a constant of proportionality. From Equation (38-15) the illuminance of an image is given by  $E = B\omega'$ , where  $B$  is the brightness of the object, and  $\omega'$  is the solid angle subtended by the lens at its image. If  $s'$  is the image distance, we have  $\omega' = (\pi d^2/4)/(s')^2$ , where  $d$  is the frontal diameter of the lens. Thus

$$\Delta t = \beta \frac{(s'/d)^2}{SB}, \quad (39-1)$$

where  $\beta$  is a new proportionality constant. Thus the exposure time  $\Delta t$  is decreased by using a film of higher speed  $S$ , by photographing a source of high brightness  $B$ , by decreasing the image distance  $s'$ , or by using a lens of larger diameter  $d$ . Photographic exposure meters measure the brightness of the source and are provided with a computing scale which is correct for a distant object, in which case the image distance  $s'$  is equal to the focal length of the lens  $f$ . The number  $f/d$  is called the *f number* of a lens, generally given as  $f/4.5$ , or  $f/2$ . For other cases the indication of the exposure meter must be corrected for the proper image distance.

### 39-2 Projection Lantern

The projection lantern forms a real, inverted, and enlarged image on a screen which is at a great distance from the projection lens when the object is placed very close to the principal focus of the lens, as shown in Figure 39-2. Projection lanterns are widely used for the projection of motion pictures and lantern slides and for photographic enlarging. The system is focused by moving the lens with respect to the slide until a clear sharp

image is obtained. The slide must be uniformly and brightly illuminated. This is accomplished by using a very intense source of light, such as a carbon arc or a specially designed tungsten-filament projection lamp, and directing the light by means of a condenser lens so that every point of the source sends light to each point of the object and toward the projection lens. In Figure 39-2 a small section  $AB$  of the object is shown illuminated

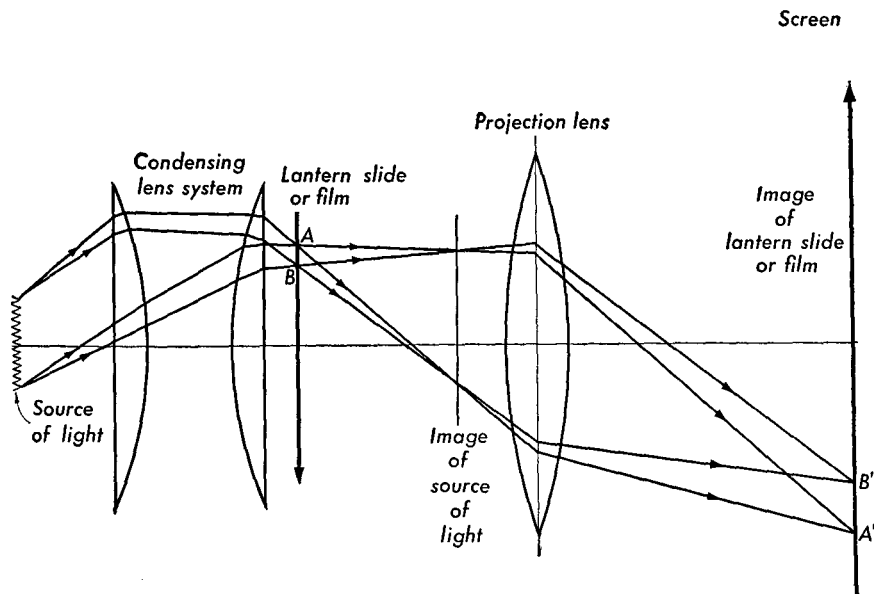

Fig. 39-2 A projection lantern.

by light from the two extreme points of the source. Rays of light from all intermediate points may be traced in a similar manner through the condensing lens system and through  $AB$ . These rays converge and form an image of the source of light at, or very close to, the projection lens. The latter should be large enough so that all of the light goes through it. The projection lens forms a real, inverted, and enlarged image  $A'B'$  of the section  $AB$ . The image of every other section of the object may be traced in a similar manner. Focusing of the image on the screen is usually accomplished by moving the projection lens, keeping the object in a fixed position relative to the source of light.

The projection lantern can also be used for opaque projection, that is, for projecting pictures on opaque backings, by interposing mirrors between the condenser and the projection lens so that light is reflected properly from the opaque object.

### 39-3 The Eye

Many optical instruments are designed to be used in conjunction with the eye. The general structure of the eye is shown in Figure 39-3. Light enters the eye through the *cornea* *C* and passes through the *aqueous humor* *A*, of

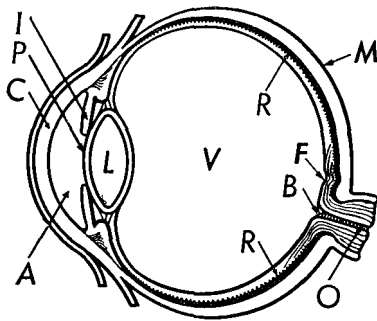
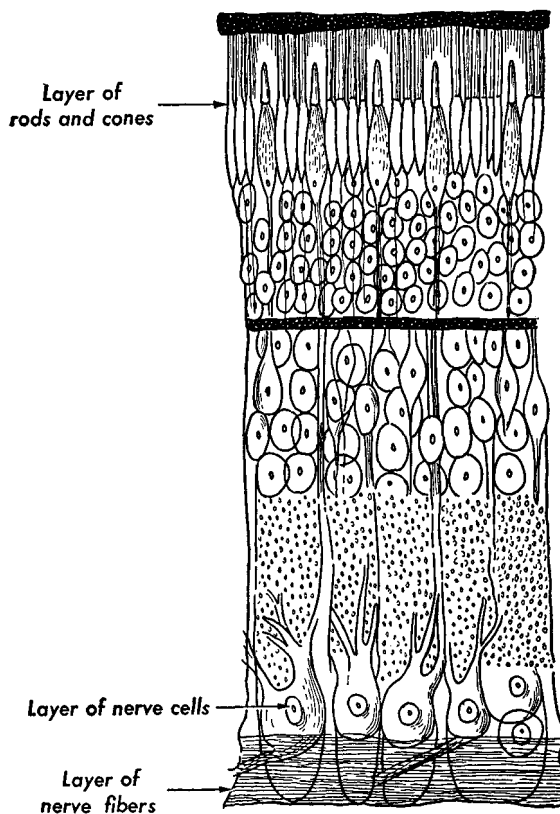

**Fig. 39-3** Longitudinal section of a human eye.

refractive index 1.35; the light then passes through the *pupil* *P*, the opening in the *iris* diaphragm *I*, and through the crystalline lens *L*. The lens is a lens-shaped transparent organ, suspended in the eyeball by a ring of tissue attached to the walls. The index of refraction of the lens varies from 1.388 for the outer layers to 1.411 for the inner layers. After passing through the lens, the light goes through a transparent jellylike substance called the *vitreous humor* *V*, of refractive index 1.336, until it strikes the *retina* *R*, which is the light-sensitive part of the eye. The retina is composed mainly of nerve tissue, which is connected to the brain by the optic nerve *O*. The image formed on the retina is real, inverted, and smaller than the object. The *optic axis* of the eye is a line passing through the vertex of the cornea and the center of the pupil.

The retina is a transparent membrane situated between the outer coating of the vitreous humor and the *choroid membrane* *M*. A section of the human retina is shown in Figure 39-4. It consists of eight fairly well defined layers; the outermost layer consists of *rods* and *cones*; the innermost layer consists of nerve fibers which lead from the rods and cones through the other layers to the optic nerve; the latter carries the impulses to the visual center in the brain. The retina is not uniformly sensitive throughout its area. At the place where the optic nerve enters the eye is the blind spot *B*; there is no vision when light falls on this spot. See Figure 39-3. A short distance away there is a small indentation called the *fovea* *F*, which is the most sensitive part of the retina. The fovea is approximately in the center of the retina and is about 0.5 mm in diameter. It contains over 30,000 cones, each with a separate nerve. There are no rods in the fovea. Rods appear in the other parts of the retina, and in the peripheral area practically only rods are present. That part of the image which falls on the fovea is seen most distinctly. Each rod or cone reacts to light as a unit. In the fovea the cones vary in size from about 0.0015 to 0.0054 mm in diameter, while the cones in the other parts of the eye are much larger. This sets a limit on the smallest details the eye can resolve. The resolving

power of the eye is about  $1'$  of arc. A pattern of dots or stars subtending less than  $1'$  of arc is seen as a blur. The field of distinct vision in the fovea is about  $1^\circ$ , and the rest of the eye is generally used as a means of centering



**Fig. 39-4** Diagrammatic section of the human retina. Light enters from bottom of figure.

the desired image on the fovea. Thus, in reading, words are successively focused on the fovea.

The color sensitivity of the eye is associated with the cones. Incidentally, the relative response of the eye to different wavelengths is also dependent upon the intensity. Colored slides viewed in dim light sometime appear to have a different color balance than the same slides viewed in brilliant light. The rods are more sensitive than the cones and are responsible for night vision. In very dim light, colored objects are seen as shades of gray. Very faint objects can sometimes be seen by peripheral vision, where only rods are present, but they disappear when viewed directly by the cones in the fovea.

The eye lens is virtually uncorrected for chromatic aberration and suffers from spherical aberration. As the level of illumination is changed,

the sensitivity of the eye is changed, a process known as *adaptation*. The peripheral rods which are not sensitive to red light appear to control adaptation, so that a person wishing to become dark-adapted may wear red goggles in ordinary light, seeing by foveal vision, and become dark-adapted without having to wait long periods in dimly lit rooms.

Objects at various distances from the eye must form images on the retina if they are to be seen clearly. Since the image distance from the cornea to the retina is fixed, the only way this can be done is through a change in the effective focal length of the eye. This is called *accommodation* of the eye; it is accomplished by changing the shape of the crystalline lens through a change in the tension of the circular ligament supporting it.

In discussing the optics of the eye and the correction of certain defects with the use of lenses, it is common to talk about the *power* of the eye, or the power of the lens, instead of the focal length. The power of a lens is expressed in *diopters* and is defined as the reciprocal of the focal length expressed in meters. For example, if the focal length of a lens is 50 cm, that is, 0.5 m, its power is 2 diopters.

Each eye has a certain *range of accommodation*. This is the distance, measured along the optic axis, between the *near point* and the *far point* of the eye. The far point is that point on the optic axis which is sharply imaged on the retina when the eye is at its weakest power. The power of the relaxed normal eye is about 59 diopters. The near point is that point on the optic axis which is sharply imaged on the retina when the accommodation of the eye is most strongly exerted, or when the power of the eye is greatest. Eyes are classified according to the position of the far and near points, and to the range of accommodation. An object located from about 20 ft to infinity may be seen clearly without accommodation by a normal eye, for, as the object moves in from infinity, the image moves from the tips to the bases of the rods and cones.

The *emmetropic*, or normal, eye is one whose far point is at infinity and whose near point is close to the eye; this point is generally taken to be about 25 cm or 10 in.

The *myopic*, or nearsighted, eye has its far point at a finite distance from the eye; its near point is closer than in the normal eye. An eye is usually myopic because the eye is too long for its lens, or the lens is too strong for the eye. Myopia is usually corrected by the use of divergent lenses in spectacles, as shown in Figure 39-5.

The *hyperopic*, or *farsighted*, eye has a far point which is virtual; that is, its far point is situated behind the eye. The eye lens does not converge sufficiently to focus a nearby object on the retina. An eye is usually hyperopic because it is too short. Hyperopia is corrected by the use of spectacles of positive power, as illustrated in Figure 39-6.

The *presbyopic* eye is one which has lost some of its power of accommo-

ation because of the decrease in the elasticity of the lens tissue due to age. The amplitude of accommodation is very great during adolescence and is negligible beyond 60 years of age. The near point moves inconveniently far from the eye. The usual correction for presbyopia is a positive lens to be used for reading or viewing objects close to the eye.

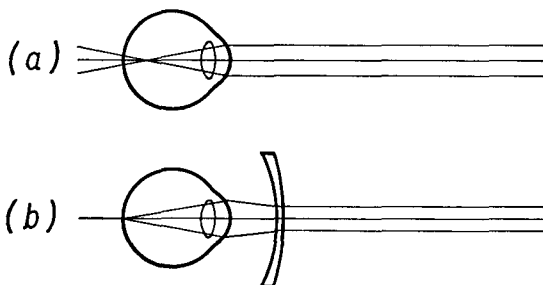

Fig. 39-5 (a) Myopia. (b) Myopia corrected by a lens of negative power.

A common defect of the eye, known as *astigmatism*, is due to the fact that the curvature of the cornea, or of the lens, is not the same in all directions about the optic axis. The cornea may be thought to have cylindrical curvature as well as spherical curvature. The astigmatic eye, view-

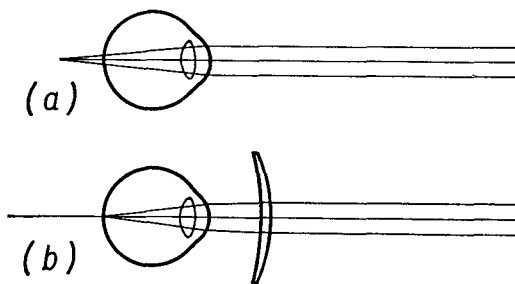

Fig. 39-6 (a) Hyperopia. (b) Hyperopia corrected by a positive lens.

ing a collection of lines drawn out from the center of a circle, sees one group of radii sharply, while radii roughly perpendicular to these are seen less sharply. Thus, for example, the vertical lines may be clearly distinguished, while horizontal lines are less clear. In reading, an *e* may be perceived as a *c* by an astigmatic eye. Astigmatism is corrected by use of cylindrical lenses with axes properly oriented.

### 39-4 The Magnifying Glass

When an object is to be examined minutely, it is usually brought as close as possible to the eye. The closer it is brought, the larger is the visual angle



$\alpha$  which it subtends at the eye, and the larger is its image on the retina, as shown in Figure 39-7. The image cannot be seen in sharp focus if the object is brought closer than the near point. This fact imposes a limit on the size of the retinal image and the smallness of detail which can be seen.

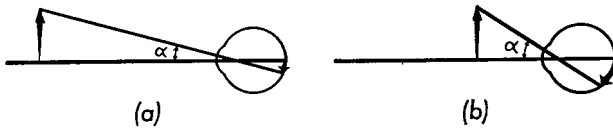

Fig. 39-7 The visual angle determines the apparent size of the object.

The visual angle can be increased and a magnified retinal image obtained with the aid of a converging lens used as a *magnifying glass*. To use the lens as a magnifier, the object is placed between the principal focus and the lens, as shown in Figure 39-8. The image is virtual and, for best

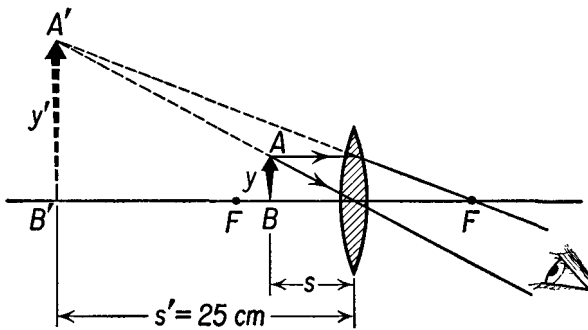

Fig. 39-8 Magnifying glass.

viewing, is formed at the near point at approximately 25 cm from the eye. If  $y'$  is the size of the image and  $y$  is the size of the object, the magnification  $m$  is given by

$$m = \frac{y'}{y} = -\frac{s'}{s},$$

where  $s'$  is the image distance and  $s$  is the object distance. From the lens equation

$$\frac{1}{s} = \frac{1}{f} - \frac{1}{s'},$$

so that

$$m = -\frac{s'}{f} + 1.$$

If we take the near point as 25 cm, we have  $s' = -25$  cm and

$$m = \frac{25 \text{ cm}}{f} + 1. \tag{39-2}$$

A single lens is seldom used for magnifications greater than about 5 because of the amount of spherical and chromatic aberration produced. Two common types of eyepieces or *oculars* used in optical instruments are

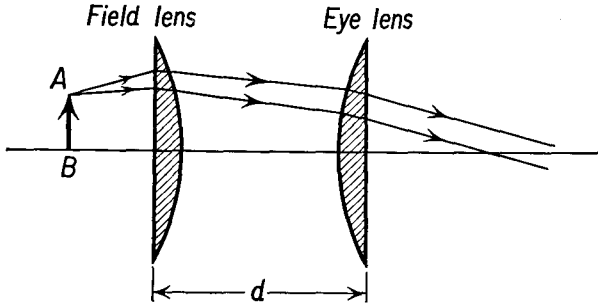

**Fig. 39-9** Ramsden ocular consists of two plano-convex lenses of equal focal length separated by a distance equal to about two thirds of the focal length of either one.

the Ramsden ocular and the Huygens ocular. These are designed to reduce spherical and chromatic aberrations to a minimum while using lenses made of the same kind of glass. The Ramsden ocular, shown in Figure 39-9, consists of two converging lenses of equal focal lengths separated by two

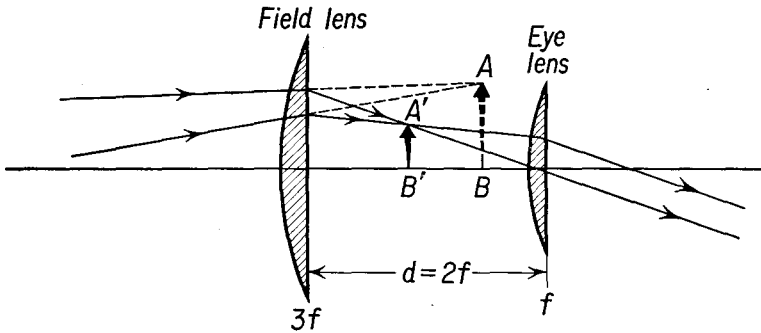

**Fig. 39-10** Huygens ocular. Field lens has a focal length three times the eye lens. The distance between the lenses  $d = 2f$ , where  $f$  is the focal length of the eye lens.

thirds of the focal length of either. The lenses are planoconvex and are mounted so that the curved surfaces face each other. If  $f$  is the focal length of either lens, the effective focal length of the eyepiece is  $3f/4$ .

The Huygens ocular, shown in Figure 39-10, consists of two plano-convex lenses, the focal length of one being three times that of the other.

The two lenses are mounted with their curved surfaces facing in the same direction; the distance between the lenses is half the sum of their focal lengths. The lens with the shorter focal length is used nearer to the eye. If  $f$  is the focal length of the eye lens, the focal length of the combination is  $3f/2$ .

### 39-5 The Astronomical Telescope

In the use of an optical instrument, it is generally desirable that the image be in approximately the same position as the object, so that the focus of the eye can be shifted from the instrument to the position of the object without accommodation. Thus, in the case of the magnifier, the image is formed at

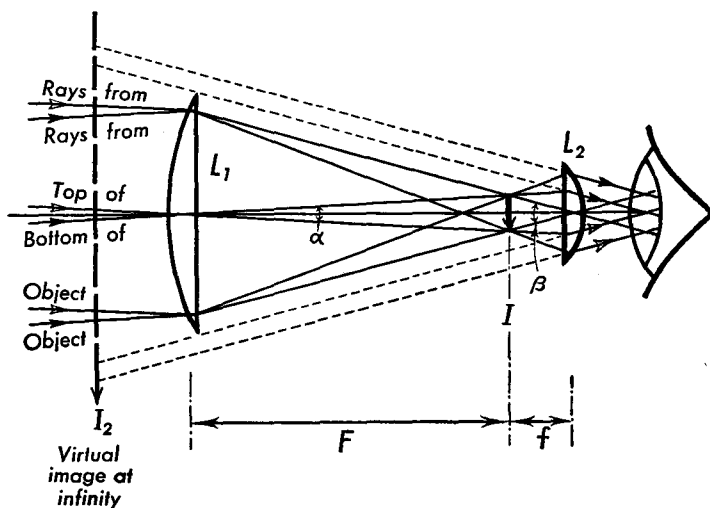

Fig. 39-11 Optical diagram of a simple astronomical telescope.

the near point, while in the case of the telescope, the image is formed at the far point. The astronomical telescope does not bring the image of the moon or of a planet closer to the eye but, rather, causes the image to subtend a larger angle. It is convenient to speak of the *angular magnification*  $M$  of the telescope as the ratio of the angle  $\beta$  subtended by the image to the angle  $\alpha$  subtended by the object, thus

$$M = \beta/\alpha. \quad (39-3)$$

In its simplest form the astronomical telescope consists of two converging lenses—an objective lens  $L_1$  and an eye lens  $L_2$ . The rays of light from one point on a distant object come into the telescope parallel to each other and inclined at a small angle  $\alpha$  to the principle axis. These rays are focused at

a point in the focal plane of the objective. When the eye lens  $L_2$  is placed at a distance equal to its focal length  $f$  from the principal focus of the objective, the rays from the image in the focal plane of the objective will leave the eye lens as parallel rays, as shown in Figure 39-11. In other words, parallel rays entering the objective lens leave the eye lens as parallel rays. The distance between the two lenses is  $F + f$ , where  $F$  is the focal length of the objective. From the figure the magnification of the telescope is

$$M = \frac{\beta}{\alpha} = \frac{F}{f}. \quad (39-4)$$

One very important function of the astronomical telescope is to collect more light than would be incident upon the retina with the naked eye. If all of the light incident upon the objective lens passes through the eye lens and is focused upon the retina, the luminous flux from a distant star is increased in the ratio of the area of the objective lens to the area of the pupil of the eye. This greatly enhances the visibility of faint celestial objects.

The image produced in the astronomical telescope is inverted, but this causes no difficulty in observing stellar objects.

### 39-6 The Terrestrial Telescope

Since the astronomical telescope produces inverted and reversed images, it is unsuitable for most terrestrial uses. The astronomical telescope can be modified to produce an erect image by inserting a converging lens between

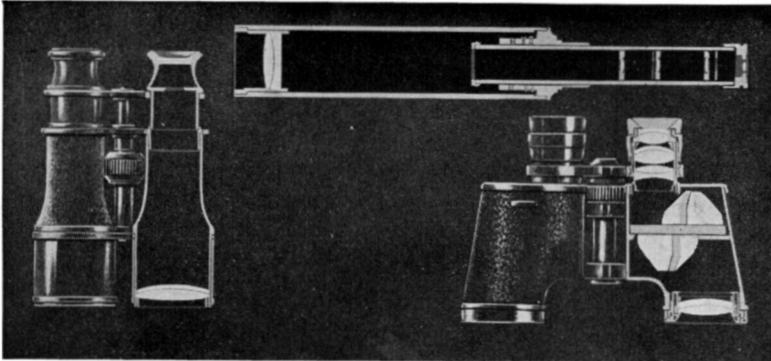

**Fig. 39-12** Cut-away sections for comparison of the three types of terrestrial telescopes. (Courtesy of Bausch & Lomb Optical Company.)

the focal plane of the objective and the eye lens, as shown in Figure 39-12. Usually, terrestrial telescopes use an erecting system consisting of two con-

verging lenses with a diaphragm or stop between them to correct for spherical aberration. In the prism binocular the physical length of the telescope is shortened, and the image is erected by use of a pair of Porro prisms. Another method for producing an erect image is to make a Galilean telescope which uses a diverging lens for an eyepiece, as shown in Figure 39-13. The distance between the objective and eyepiece is  $F - f$ , where  $F$  is the focal length of the objective, and  $f$  is the focal length of the eye-

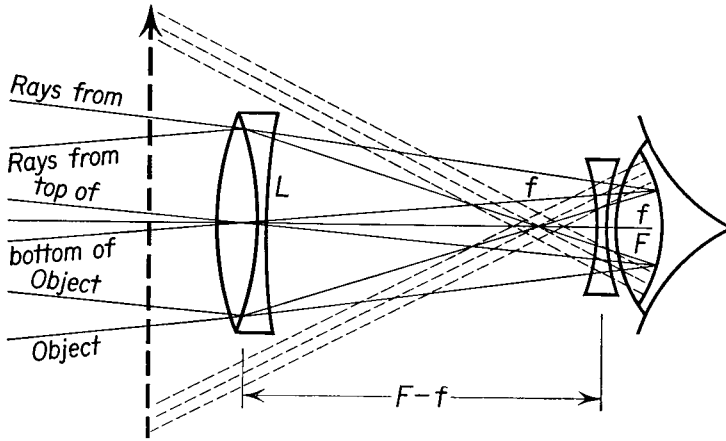

Fig. 39-13 Optical diagram of a Galilean telescope or opera glass.

piece. Parallel rays from the object are converged toward the focal plane of the objective and are deviated by the negative eye lens so that they emerge as parallel rays, forming a virtual image at infinity. Galilean telescopes are extensively used as opera glasses.

In a binocular used for daytime viewing, it is desirable that the brightness of the image through the binocular be approximately the same as the brightness of the object, so that there is no necessity for adaptation of the eye when viewing the image first through the binocular and then without its aid, as in following the flight of a bird. The average diameter of the pupil of the eye is about 5 mm. A binocular having an angular magnification of 8 and a front lens whose diameter is 40 mm (rated as an 8 x 40 binocular) gathers  $(40/5)^2$  as much light as the eye but distributes this light over a retinal area  $8^2$  as great as the area illuminated by the unaided eye. Thus we see that an 8 x 40 binocular provides the retina with illumination comparable to the unaided eye. An 8 x 50 binocular yields an image of greater brightness, while an 8 x 30 binocular provides an image of lesser brightness than the unaided eye, provided that all the light entering the objective passes into the eye. Large-diameter objective lenses are gener-

ally used for night glasses or for viewing shaded objects rather than for general-purpose daytime observation.

### 39-7 The Compound Microscope

The compound microscope consists of two systems of converging lenses, shown in Figure 39-14 as single converging lenses. The objective lens  $L_1$  has a very short focal length  $F$ , and the object is placed very close to but

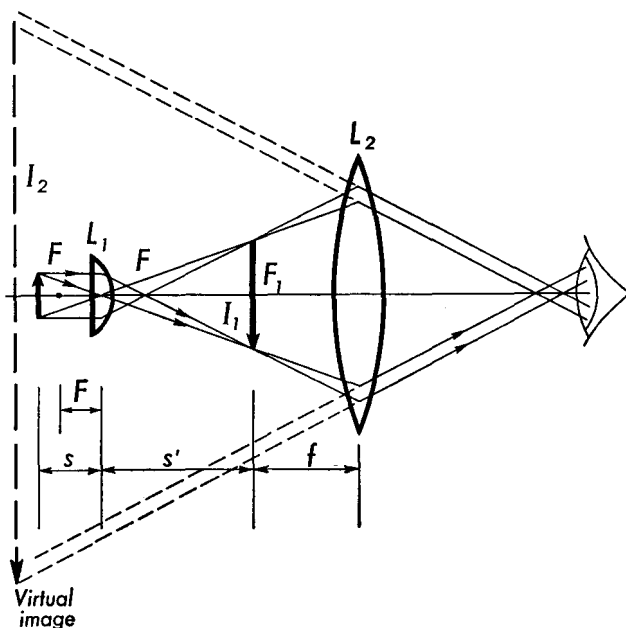

Fig. 39-14 Simplified optical diagram of a compound microscope.

just outside the principal focus of this lens. A real inverted image  $L_1$  is formed at a distance  $s'$  from the objective lens. The eye lens  $I_2$  is used for viewing this image. It is desirable for the image to be formed at the near point, located between the position of the specimen and the laboratory table, as shown in Figure 39-15. The magnification  $m_1$  produced by the objective is

$$m_1 = \frac{s'}{s}.$$

To a good approximation the object distance is very nearly equal to the focal length of the objective lens  $F$ . Thus we may write

$$m_1 = \frac{s'}{F}.$$

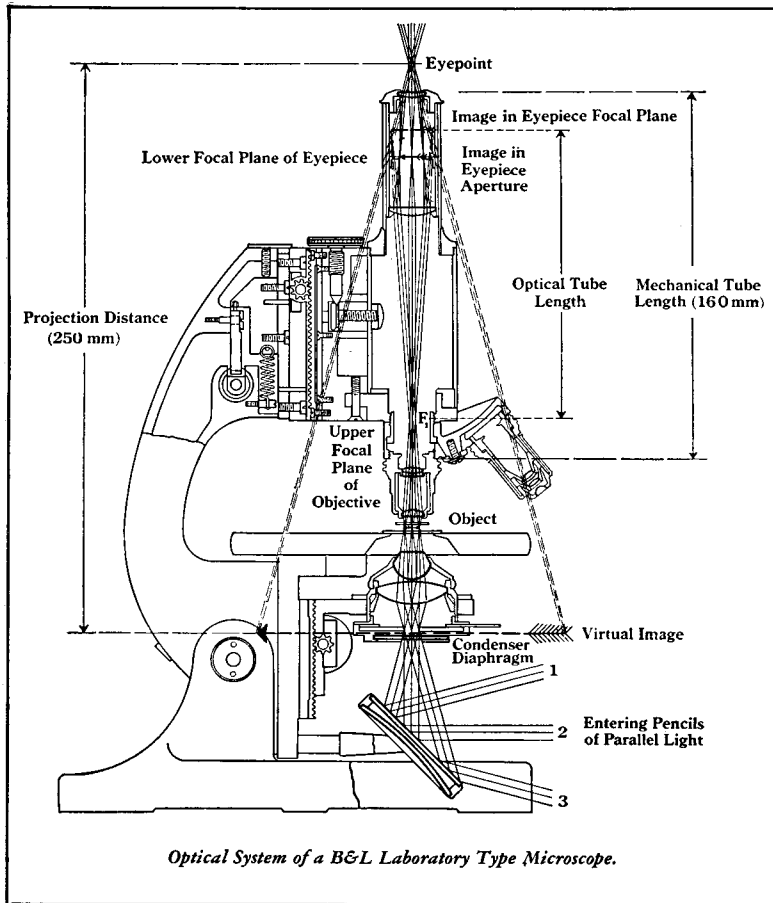

**Fig. 39-15** Complete optical system of a compound microscope. (Courtesy of Bausch & Lomb Optical Company.)

Similarly, the magnification  $m_2$  produced by the eye lens may be approximated as

$$m_2 = \frac{25 \text{ cm}}{f},$$

neglecting the 1 in Equation (39-2), where  $f$  is the focal length in centimeters, of the eye lens. The total magnification  $m$  of the compound microscope is

$$m = m_1 m_2 = \frac{s'}{F} \times \frac{25 \text{ cm}}{f}. \quad (39-5)$$

Magnifications of several hundred diameters are common with com-

pound microscopes, so that the area of the image is tens of thousands of times the area of the object. The object must be strongly illuminated to provide sufficient illumination for the image to be seen. This is usually accomplished by focusing light onto the object from a bright source by means of a mirror and a condensing lens, as shown in Figure 39-15.

### 39-8 The Prism Spectroscope

A prism spectroscope is used for determining the composition of the light incident upon it from a source. The light enters a narrow slit  $S$ , placed at the principal focus of a converging lens, and emerges as a parallel beam, as shown in Figure 39-16. The light is said to be *collimated* by this lens. The slit and lens are mounted at the ends of a light-tight tube called a

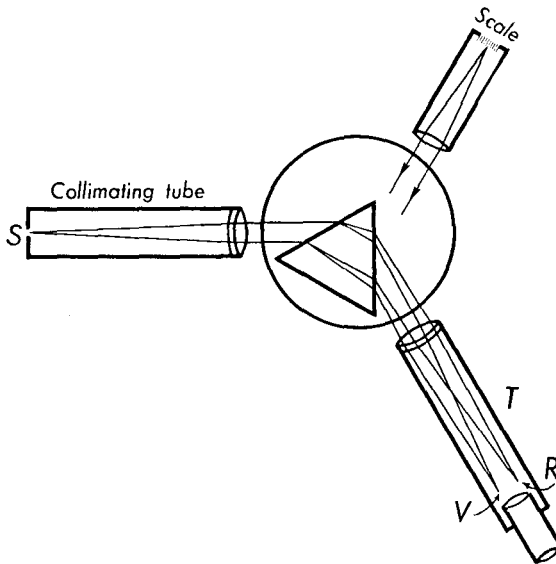

Fig. 39-16 A prism spectroscope.

*collimating tube*. The purpose of the collimator is to avoid astigmatism in the final beam. The collimated light is dispersed by a prism made of some suitable transparent material, such as glass, quartz, or rock salt. Rays of any small wavelength interval are deviated through nearly the same angle and emerge from the prism in a parallel beam. The telescope  $T$  can be rotated so that its axis is parallel to any one beam, and that beam is converged to the principal focus of the telescope objective. Each converged beam is an image of the slit formed by monochromatic light. Since the spectrum of a monochromatic source appears as a line, we speak of



discrete spectra as line spectra. In contrast, an incandescent body emits a continuous spectrum. The images of the slit are viewed with the aid of the telescope eyepiece. A scale in a side tube is sometimes brought into the field of view by reflecting it from one face of the prism, for purposes of measurement or calibration. A prism spectroscope can only be used for the measurement of wavelength when it has been calibrated with known spectral lines. Wavelengths cannot be measured directly with the spectroscope, for the spectroscope provides no direct means for comparing the wavelength of light with a standard of length. Such primary measurements of wavelength are made by means of interference and diffraction effects, to be discussed in the next chapter.

### Problems

39-1. A lantern slide 3 in. wide is to be projected on a screen 6 ft wide at a distance of 25 ft from the projection lens. The picture should fill the whole screen. What should be the focal length of the projection lens?

39-2. (a) Determine the magnification produced by a converging lens used as a magnifier if its focal length is 4 in. (b) If this lens is used by a person whose near point is 15 cm, what is the greatest magnification he can obtain?

39-3. A person has a near point of 100 cm. What spectacle lens should he wear so that he can read newsprint at a distance of 25 cm from his eye?

39-4. The far point of a myopic eye is 50 cm. What is the focal length of the lens which should be placed in front of this eye so that it can see infinitely distant objects?

39-5. A farsighted person is prescribed lenses of +2.00 diopters. What is his near point?

39-6. What is the power of a converging lens which produces a magnification of  $5\times$  when used as a simple magnifier?

39-7. (a) What is the focal length of a spectacle lens of  $-1.5$  diopters? (b) What is the far point of the eye for which this spectacle lens is prescribed?

39-8. A small laboratory telescope has an objective whose focal length is 18 cm and an eye lens whose focal length is 3 cm. (a) What is the angular magnification of the telescope? (b) How far apart are the lenses? (c) If this telescope is focused on the moon, whose angular diameter is approximately  $\frac{1}{2}^\circ$ , what will be the angular diameter of the image?

39-9. A camera lens whose focal length is 3 in. has its position relative to the film adjustable for object distances from 3.5 ft to infinity. Determine the maximum displacement of the lens for these extreme positions.

39-10. A compound microscope has an objective of 4 mm focal length which forms an image 15 cm from it. The eye lens has a focal length of 2.5 cm and forms an image 25 cm from the eye lens. Determine the linear magnification of the microscope.

39-11. The distance between the objective lens and the eye lens of an astronomical telescope, when adjusted for parallel light, is 80 cm. Determine

the focal length of the lenses when the measured value of the angular magnification is 12.

39-12. A box camera of the fixed-focus type has a lens whose focal length is 4 in. and whose diameter is 0.5 in. Determine the positions of the images formed when the objects are (a) 6 ft, (b) 15 ft, and (c) 25 ft from the lens. (d) If the lens is set at the proper image distance for an object 10 ft from the lens, how large will the illuminated area be from a point source 6 ft from the lens?

39-13. The field lens of a Huygens ocular has a focal length of 9 cm, and the eye lens has a focal length of 3 cm. The lenses are spaced 6 cm apart. Determine the effective focal length of this ocular. Trace two parallel rays through this ocular, assuming (a) that they enter through the field lens and (b) that they enter through the eye lens. Determine the focal point in each case.

39-14. The lenses of a Ramsden ocular have focal lengths of 9 cm each and are placed 6 cm apart. (a) Determine the effective focal length of this ocular. Trace two parallel rays through this ocular and determine the position of the focal point.