

University of Nebraska - Lincoln

DigitalCommons@University of Nebraska - Lincoln

Nebraska Tractor Tests

Tractor Test and Power Museum, The Lester F.
Larsen

January 2001

Test 1789: John Deere 9200 24 & 12 Speed

Nebraska Tractor Test Lab

University of Nebraska-Lincoln, tractortestlab@unl.edu

Follow this and additional works at: <https://digitalcommons.unl.edu/tractormuseumlit>



Part of the [Energy Systems Commons](#), [History of Science, Technology, and Medicine Commons](#), [Other Mechanical Engineering Commons](#), [Physical Sciences and Mathematics Commons](#), [Science and Mathematics Education Commons](#), and the [United States History Commons](#)

Nebraska Tractor Test Lab, "Test 1789: John Deere 9200 24 & 12 Speed" (2001). *Nebraska Tractor Tests*. 182.

<https://digitalcommons.unl.edu/tractormuseumlit/182>

This Article is brought to you for free and open access by the Tractor Test and Power Museum, The Lester F. Larsen at DigitalCommons@University of Nebraska - Lincoln. It has been accepted for inclusion in Nebraska Tractor Tests by an authorized administrator of DigitalCommons@University of Nebraska - Lincoln.

NEBRASKA TRACTOR TEST 1789

JOHN DEERE 9200 DIESEL

24 SPEED ALSO 12 SPEED

(Chassis S/N *RW9200H0040522* and higher)

POWER TAKE-OFF PERFORMANCE

Power HP (kW)	Crank shaft speed rpm	Gal/hr (l/h)	lb/hp.hr (kg/kWh)	Hp.hr/gal (kW.h/l)	Mean Atmospheric Conditions
MAXIMUM POWER AND FUEL CONSUMPTION					
Rated Engine Speed—(PTO speed—1108 rpm)					
267.62 (199.56)	2100	15.26 (57.76)	0.401 (0.244)	17.54 (3.45)	
Standard Power Take-off Speed—(PTO speed—1000 rpm)					
296.97 (221.45)	1895	15.78 (59.75)	0.374 (0.227)	18.81 (3.71)	
Maximum Power (2 hours)					
309.21 (230.58)	1800	16.52 (62.55)	0.375 (0.228)	18.71 (3.69)	

VARYING POWER AND FUEL CONSUMPTION

267.62 (199.56)	2100	15.26 (57.76)	0.401 (0.244)	17.54 (3.45)	Air temperature
233.52 (174.14)	2157	13.92 (52.68)	0.419 (0.255)	16.78 (3.31)	76°F (25°C)
176.99 (131.98)	2175	11.91 (45.09)	0.473 (0.288)	14.86 (2.93)	Relative humidity
118.41 (88.30)	2192	9.99 (37.82)	0.593 (0.361)	11.85 (2.33)	34%
59.57 (44.42)	2200	7.34 (27.80)	0.866 (0.527)	8.11 (1.60)	Barometer
1.66 (1.24)	2200	4.74 (17.94)	20.086 (12.218)	0.35 (0.07)	28.91" Hg (97.90 kPa)

Maximum Torque - 1020 lb.-ft. (1383 Nm) at 1199 rpm
 Maximum Torque Rise - 52.5%
 Torque rise at 1699 engine rpm - 42%

TRACTOR SOUND LEVEL WITH CAB

	dB(A)
At no load in 7th (B1 Lo) gear	72.5
Transport speed - no load - 24th (D3 Hi) gear	76.0
Bystander in 24th (D3 Hi) gear	88.1

TIRES AND WEIGHT

Rear Tires - No., size, ply & psi (kPa)
Front Tires - No., size, ply & psi (kPa)
Height of Drawbar
Static Weight with operator - Rear
 - Front
 - Total

Tested Without Ballast

Four 520/85R42; **; 8(55)
 Four 520/85R42; **; 13(90)
 20.0 in (560 mm)
 13590 lb (6164 kg)
 19565 lb (8875 kg)
 33155 lb (15039 kg)

Location of Test: Nebraska Tractor Test Laboratory, University of Nebraska, Lincoln, Nebraska 68583-0832

Dates of Test: March 29-April 11, 2001

Manufacturer: John Deere Tractor Works, 3500 East Donald St., P.O. Box 270, Waterloo Ia, USA

FUEL, OIL and TIME: Fuel No. 2 Diesel Specific gravity converted to 60°/60°F (15°/15°C) 0.8439 Fuel weight 7.027 lbs/gal (0.842 kg/l) Oil SAE 15W-40 API service classification CH-4 Transmission and hydraulic lubricant John Deere Hy-Gard fluid Total time engine was operated: 13.5 hours

ENGINE: Make John Deere Diesel **Type** six cylinder vertical with turbocharger and air to air aftercooler **Serial No.** *RG6125H030013* **Crankshaft** lengthwise **Rated engine speed** 2100 **Bore and stroke** 5.00" x 6.50" (127.0 mm x 165.0 mm) **Compression ratio** 17.0 to 1 **Displacement** 765 cu in (12535 ml) **Starting system** 12 volt **Lubrication** pressure **Air cleaner** two paper elements and aspirator **Oil filter** one full flow cartridge **Oil cooler** engine coolant heat exchanger for crankcase oil, radiator for hydraulic oil, radiator for transmission and final drive oil **Fuel filter** one paper element and water separator **Muffler** vertical **Cooling medium temperature control** 2 thermostats and variable speed fan

ENGINE OPERATING PARAMETERS: Fuel rate: 102.5 - 110.0 lb/h (46.5 - 49.9 kg/h) **High idle:** 2160 - 2240 rpm **Turbo boost:** nominal 13.5 - 16.4 psi (93 - 113 kPa) as measured 15.6 psi (107 kPa)

CHASSIS: Type four wheel drive with duals **Serial No.** *RW9200H040594* **Tread width** rear 63.0" (1600 mm) to 135.9" (3453 mm) front 63.0" (1600 mm) to 135.9" (3453 mm) **Wheelbase** 137.8" (3500 mm) **Hydraulic control system** direct engine drive **Transmission** selective gear fixed ratio with partial (2) range operator controlled power shift **Nominal travel speeds mph (km/h)** first 2.09 (3.36) second 2.50 (4.03) third 2.69 (4.33) fourth 3.22 (5.19) fifth 3.68 (5.92) sixth 4.41 (7.10) seventh 4.45 (7.17) eighth 4.91 (7.90) ninth 5.34 (8.59) tenth 5.73 (9.22) eleventh 5.88 (9.47) twelfth 6.32 (10.17) thirteenth 6.87 (11.06) fourteenth 7.58 (12.19) fifteenth 7.85 (12.63) sixteenth 8.65 (13.92) seventeenth 9.40 (15.13) eighteenth 10.37 (16.69) nineteenth 10.46 (16.84) twentieth 12.54 (20.18) twenty-first 13.47 (21.67) twenty-second 16.14 (25.98) twenty-third 18.43 (29.66) twenty-fourth 22.10 (35.56) reverse 2.51 (4.03), 3.00 (4.83), 5.34 (8.59), 5.89 (9.47), 6.40 (10.30), 7.06 (11.36)

THREE POINT HITCH PERFORMANCE (OECD Static Test)

CATEGORY: III

Quick Attach: yes

Maximum Force Exerted Through Whole Range: 13104 lbs (58.3 kN)

i) Opening pressure of relief valve: NA

Sustained pressure at compensator cutoff: 2920 psi (201 bar)

Single outlet set Two outlet sets combined

ii) Pump delivery rate at minimum pressure and rated engine speed:

31.6 GPM (119.6 l/min) 45.6 GPM (172.6 l/min)

iii) Pump delivery rate at maximum

hydraulic power:

28.3 GPM (107.1 l/min) 42.6 GPM (161.3 l/min)

Delivery pressure:

2250 psi (155 bar) 2300 psi (159 bar)

Power:

37.1 Hp (27.7 kW) 57.2 HP (42.6 kW)

THREE POINT HITCH PERFORMANCE

Observed Maximum Pressure psi. (bar): 2950 (203)

Location: remote outlet

Hydraulic oil temperature: °F (°C): 147 (64)

Location: hydraulic sump

Category: III

Quick attach: yes

SAE Static Test—System pressure 2680 psi (185 Bar)

Hitch point distance to ground level in. (mm) 8.0 (203) 16.0 (406) 24.0 (610) 32.0 (813) 40.0 (1016)

Lift force on frame lb 14589 14463 14418 13995 12978

" " " " " " (kN) (64.9) (64.3) (64.1) (62.3) (57.7)

ASAE Static Test—System pressure 2860 psi (197 Bar)

Hitch point distance to ground level in. (mm) 8.0 (203) 16.0 (406) 24.0 (610) 32.0 (813) 40.0 (1016)

Lift force on frame lb 15715 15580 15531 15076 13980

" " " " " " (kN) (69.9) (69.3) (69.1) (67.1) (62.2)

HITCH DIMENSIONS AS TESTED—NO LOAD

	inch	mm
A	30.8	780
B	18.6	472
C	26.2	666
D	24.4	620
E	11.3	288
F	13.8	350
G	35.6	905
H	4.8	122
I	22.7	577
J	21.8	555
K	28.8	731
L	55.3	1405
*L'	61.8	1570
M	25.4	645
N	44.0	1117
O	8.0	203
P	48.6	1234
Q	39.1	993
R	44.8	1137

*L' to Quick Attach ends

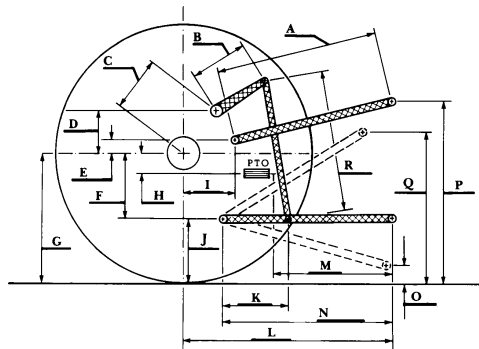

John Deere 9200 Diesel

Clutch wet multiple disc hydraulically actuated by foot pedal **Brakes** wet multiple disc hydraulically actuated foot pedal **Steering** hydrostatic and articulated **Power take-off** 1000 rpm at 1895 engine rpm **Unladen tractor mass** 32980 lb (14959 kg)

REPAIRS AND ADJUSTMENTS: No repairs or adjustments.

NOTE: The performance data on this report apply to John Deere 9200 Diesel tractors equipped with the 12.5 l engine. For drawbar performance, see Nebraska Tractor Test 1731.

REMARKS: All test results were determined from observed data obtained in accordance with official OECD, SAE and Nebraska test procedures. For the maximum power tests the fuel temperature at the injection pump inlet was maintained at 98°F(37°C).

We, the undersigned, certify that this is a true and correct report of official Tractor Test No. **1789**, June 11, 2001.

David L. Morgan
Assistant Director

L. L. Bashford
M. F. Kocher
G. J. Hoffman
Board of Tractor Test Engineers