

2009

Mitochondrial DNA Variation and Range Expansion in Western Bean Cutworm (Lepidoptera: Noctuidae): No Evidence for a Recent Population Bottleneck

Nicholas Miller

University of Nebraska-Lincoln, nmiller11@iit.edu

David L. Dorhout

Iowa State University

Marlin E. Rice

USDA-ARS, Corn Insects and Crop Genetics Research Unit, Genetics Laboratory, Iowa State University

Thomas W. Sappington

USDA-ARS, Corn Insects and Crop Genetics Research Unit, Genetics Laboratory, Iowa State University, tom.sappington@ars.usda.gov

Follow this and additional works at: <http://digitalcommons.unl.edu/entomologyfacpub>



Part of the [Entomology Commons](#)

Miller, Nicholas; Dorhout, David L.; Rice, Marlin E.; and Sappington, Thomas W., "Mitochondrial DNA Variation and Range Expansion in Western Bean Cutworm (Lepidoptera: Noctuidae): No Evidence for a Recent Population Bottleneck" (2009). *Faculty Publications: Department of Entomology*. 246.

<http://digitalcommons.unl.edu/entomologyfacpub/246>

This Article is brought to you for free and open access by the Entomology, Department of at DigitalCommons@University of Nebraska - Lincoln. It has been accepted for inclusion in Faculty Publications: Department of Entomology by an authorized administrator of DigitalCommons@University of Nebraska - Lincoln.

Mitochondrial DNA Variation and Range Expansion in Western Bean Cutworm (Lepidoptera: Noctuidae): No Evidence for a Recent Population Bottleneck

NICHOLAS J. MILLER,^{1,2} DAVID L. DORHOUT,^{3,4} MARLIN E. RICE,³ AND
THOMAS W. SAPPINGTON¹

Environ. Entomol. 38(1): 274–280 (2009)

ABSTRACT The western bean cutworm, *Striacosta albicosta* (Smith) (Lepidoptera: Noctuidae), is a pest of both corn and dry bean crops. At the beginning of the 21st century, the species began to extend its range out of the Great Plains, eastward through the Corn Belt. This rapid range expansion is remarkable because the species distribution had been stable for at least the previous half century, despite the apparent abundance of suitable habitat (i.e., cornfields) immediately to the east. We hypothesized that if the western bean cutworm had to overcome a stable barrier to movement before starting the current range expansion, it probably experienced a genetic bottleneck in doing so. To test this hypothesis, variation in the mitochondrial NADH dehydrogenase one (ND1) gene was studied in populations from Wyoming, Nebraska, and Iowa. No differences in overall genetic diversity or haplotype frequencies indicative of a bottleneck were observed between the recently founded populations in Iowa and the established populations in Wyoming and Nebraska. This result suggests that the sudden loss of an ecological exclusion mechanism, allowing the species to move east in appreciable numbers, is more likely to have triggered the range expansion than the surmounting of an extrinsic barrier to movement. The nature of this mechanism is unknown but might be related to recent changes in corn farming practices and technology.

KEY WORDS *Striacosta albicosta*, NADH dehydrogenase 1, biological invasion, *Zea mays*

The western bean cutworm, *Striacosta albicosta* (Smith) (Lepidoptera: Noctuidae), is a pest of corn (*Zea mays* L.) and dry beans (*Phaseolus vulgaris* L.) that is currently expanding its distribution eastward through the Corn Belt of the United States. The species is univoltine and overwinters as a fifth-stage larva below the soil surface (Hoerner 1948, Douglass et al. 1957). Adults emerge in early July (Hagen 1962) and oviposit on the leaves of the host plants. On beans, the larvae initially feed on the leaves and buds and later make feeding holes in the young pods (Hoerner 1948). On corn, young larvae feed over pollen, anthers, and upper leaf tissue before burrowing into the ears to feed on young kernels as fourth and fifth instars (Hagen 1962). Despite exploiting two very different crop species, *S. albicosta* does not seem to be particularly polyphagous. Blickenstaff and Jolley (1982) studied larval development on several bean species, teosinte, and several Solanaceae thought to be alternative hosts of *S. albicosta*. They concluded that all were inferior

hosts to *P. vulgaris* and corn and speculated that *S. albicosta* may have evolved on mixed crops of corn and beans grown by Native Americans.

Before the 1950s, *S. albicosta* was an occasional pest of dry beans, largely confined to Colorado, Kansas, Nebraska, and Idaho (Hoerner 1948). From 1950 onward, the species became an increasingly destructive pest of beans in western Nebraska (Hagen 1963, 1976). At about the same time, it was found attacking corn crops in southern Idaho (Douglass et al. 1957) and western Nebraska (Hagen 1962). By 1970, *S. albicosta* was established throughout most of Nebraska but remained rare east of the Missouri river (Blickenstaff and Jolley 1982). The species distribution remained stable for the remainder of the 20th century before undergoing a second, more rapid eastward expansion. In 1999, western bean cutworms were found attacking experimental plots of corn throughout southwestern Minnesota (O'Rourke and Hutchinson 2000). Although the species had been present in South Dakota for many years, it did not begin to cause economic damage until 2000 (Catangui and Berg 2006). Also in 2000, *S. albicosta* caused widespread and unexpected damage to corn crops throughout western Iowa (Rice 2000). The species spread into Illinois and Missouri by 2004 (Dorhout and Rice 2004, Rice et al. 2004) and Wisconsin in 2005 (Cullen and Jyuotika 2008), and

¹ USDA-ARS, CICGRU, Genetics Laboratory, Iowa State University, Ames, IA 50011.

² Corresponding author, nicholas.miller@ars.usda.gov.

³ Department of Entomology, Iowa State University, Ames IA 50011.

⁴ Present address: Pioneer Hi-Bred International, Johnston, IA 50131.

Indiana, Michigan, and Ohio by 2006 (Pope 2007, Rice and Pilcher 2007, DiFonzo and Hammond 2008).

It is striking that *S. albicosta* apparently remained largely confined to the west of the Missouri River for the last three decades of the 20th century despite an abundance of corn immediately to the east. This suggests the existence of some environmental factor that prevented further eastward movement during this period. Although the nature of such an environmental barrier is unknown, two general categories can be envisaged. The barrier might be durable and still in existence, as would be expected for a physical landscape feature. Alternatively, the barrier might be temporary and have recently disappeared, allowing the present range expansion to begin. A temporary barrier might consist of, for example, farming practices that make the agricultural environment unsuitable as a habitat but that can change rapidly over wide areas in response to economic or technological developments.

Although the identity of any barrier to movement by *S. albicosta* is unknown, some clues as to its nature may be obtained by comparing genetic diversity in populations that predate the current range expansion (i.e., west of the Missouri River) and new populations further east. If *S. albicosta* had to cross a durable barrier before starting the current range expansion, it is unlikely that it did so spontaneously in large numbers. Thus, we may expect that there was a population bottleneck at the beginning of the range expansion resulting in genetic founder effects associated with a small number of colonizers. If so, younger eastern populations are expected to be less genetically diverse than older populations. In addition, significant allele frequency differences would be expected between younger and older populations as a result of accelerated genetic drift during the bottleneck. However, if a temporary barrier recently dissipated, allowing large numbers of *S. albicosta* to migrate east, a bottleneck would not be expected. Under this scenario, younger populations would exhibit similar levels of genetic diversity to older populations, and no unusually high allele frequency differences would be expected between young and old populations.

An obvious prerequisite for studying genetic variation is some type of genetic marker. Where no such markers have been previously characterized, as is the case for *S. albicosta*, sequencing mitochondrial genes is convenient because catalogs are available of "universal" polymerase chain reaction (PCR) primers that can be used across a range of taxa (Simon et al. 1994, 2006). Mitochondrial genes show varying rates of evolution. RNA genes are more conserved than protein coding genes, among which evolutionary rates also vary. NADH dehydrogenases generally show higher amino acid substitution rates than cytochrome oxidases, for example (Simon et al. 1994). Thus, rapidly evolving mitochondrial genes can be used to study variation within species, whereas slower-evolving genes are better suited to studies concerned with longer evolutionary time scales. In this paper, we report a study of mitochondrial NADH dehydrogenase 1 gene sequence diversity in *S. albicosta* populations

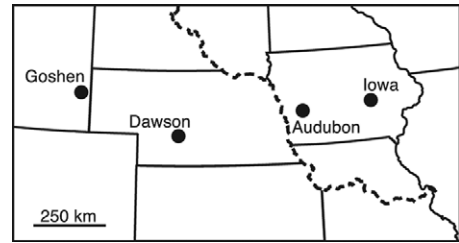

Fig. 1. Locations of western bean cutworm population samples. The course of the Missouri River is indicated by a dashed line.

from Wyoming, Nebraska, and Iowa as a first step toward understanding the processes that have resulted in the current, dramatic eastward range expansion.

Materials and Methods

Sampling and DNA Extraction. Male *S. albicosta* were collected in July 2006 from Goshen County, WY (42.246° N, 104.486° W); Dawson County, NE (40.972° N, 100.361° W); Audubon County, IA (41.697° N, 95.214° W), and Iowa County, IA (41.866° N, 92.337° W) (Fig. 1). At each location, adult males were captured in two traps placed 25 m apart. Traps were fashioned from 3.8-liter plastic milk containers into which four $\approx 60\text{-cm}^2$ holes had been cut leaving a 6-cm deep reservoir that was filled with a 4:1 mixture of water and ethylene glycol (Seymour et al. 1998, Dourhout and Rice 2008). Each trap was mounted on a pole, 1.2 m above ground level, and was baited with an *S. albicosta* sex pheromone lure (Scentry Biologicals, Billings, MT). Traps were left in the field for 10 d during the first 2 wk of July, after which dead males were removed from the ethylene glycol solution and stored at -20°C .

DNA was extracted from the thoraxes of individual *S. albicosta* using a modified CTAB (Cetyl trimethylammonium bromide) method (Marcon et al. 1999). Purified DNA was resuspended in 50 μl TE buffer and stored at -20°C . Up to 24 DNA extractions were prepared from each sample location.

Preliminary Sequencing Using Universal Primers. Universal primers (Simon et al. 2006) were used in initial attempts to PCR amplify and sequence a region of the mitochondrial NADH dehydrogenase 1 gene (ND1). PCR reactions were done in 20 μl of 1 \times GoTaq Flexi buffer (Promega, Madison, WI) containing 5 pmol of primers N1-J11876 and N1-N12595, each dNTP at 187.5 nM, 2 mM MgCl_2 , 0.5 U GoTaq Flexi DNA polymerase (Promega), and 2 μl DNA extract. A touchdown thermal cycling program was used starting with 95°C for 2 min, followed by seven cycles of 94°C for 1 min, an annealing temperature decreasing from 65°C by 2°C per cycle for 1 min and 72°C for 1.5 min, followed by 35 cycles of 94°C for 1 min, 50°C for 1 min, and 72°C for 1.5 min, with a final incubation at 72°C for 10 min. Four to six PCRs were done for each individual, which were pooled, purified with Qiaquick PCR

purification kits (Qiagen, Valencia, CA), and recovered into a final volume of 30 μ l.

PCR products were sequenced using Genome Lab DTCS Quick Start dye terminator cycle sequencing kits (Beckman Coulter, Fullerton, CA) according to the manufacturer's instructions with N1-J11876, N1-J12261, and N1-N12595 used as sequencing primers. Sequencing reaction products were separated by capillary electrophoresis using a CEQ 8000 system (Beckman Coulter). Raw data from the CEQ 8000 were analyzed with CEQ 8000 Genetic Analysis software (Beckman Coulter) and exported in SCF format. Phred (Ewing and Green 1998, Ewing et al. 1998) was used to call base sequences and calculate associated quality scores from the exported sequencer data. Sequence reads were assembled into contiguous sequence using GAP4 (Bonfield et al. 1995).

Sequencing with Species-specific Primers. Efforts to amplify and sequence a portion of the *S. albicosta* ND1 gene using universal primers proved problematic. In particular, the target amplicon failed to amplify in numerous individuals as a result of degraded template DNA, and many sequencing reads were of poor quality. However, enough high-quality data were obtained to assemble a 723-bp consensus sequence. Two pairs of PCR primers that amplified two overlapping amplicons were designed from the consensus sequence using the program Primer 3 (Rozen and Skaletsky 2000). The upstream 413-bp amplicon was amplified using primers L-16 (TTGGAGCGTAAAGTATTAGGTT) and R-429 (AAAATCCATGATTATAACAATTC), and the downstream 403-bp amplicon was amplified using primers L-302 (TTGCTGGTTGATCTTCTAATTCT) and R-705 (AAAAATAAACCCCAAATTAACC). The two amplicons overlapped by 81 bp.

The concentrations of PCR components for the species-specific primers were the same as those for universal primers except that the amount of template DNA was adjusted to 40 ng/reaction. The temperature cycling program was 95°C for 2 min followed by 35 cycles of 94°C for 1 min, 52 (L-16 + R-429) or 55°C (L-302 + R-705) for 1 min, and 72°C for 1 min, with a final incubation at 72°C for 10 min. For each amplicon, four PCRs were done for each individual, which were pooled, purified using Qiaquick kits, and recovered into 50 μ l. Each purified amplicon was sequenced in both directions using the PCR primers and DTCS Quick Start kits. Sequencing reaction products were separated by capillary electrophoresis, and the data were analyzed with CEQ 8000 software and Phred in the same manner as for the universal primers. Gap4 was used to assemble the reads from each individual into a single contiguous sequence and to manually remove sequences at the end of each read that were complementary to the amplicon's PCR primer. Additional sequencing was performed in cases where one or more low-quality reads meant that portions of the sequence from an individual were not reliable. In cases where the finished sequence was unique (i.e., not shared with any other individual), the entire species-specific PCR and sequencing process was repeated to

confirm that the unique sequences were not caused by PCR or sequencing errors.

Sequencing of Black Cutworm ND1. To obtain an outgroup to the *S. albicosta* sequences, the same region of the mitochondrial ND1 gene was sequenced from black cutworm, *Agrotis ipsilon* (Hufnagel) (Lepidoptera: Noctuidae). *A. ipsilon* DNA was used as template in a PCR with universal primers N1-J11876 and N1-N12595. The PCR product was purified using a Qiaquick kit and cloned into pGEM-T vector (Promega) according to the manufacturer's instructions, which was used to transform *E. coli* strain XLI-Blue (Stratagene, La Jolla, CA). Plasmid DNA was prepared from eight clones using a Zippy miniprep kit (Zymo Research, Orange, CA) and sequenced using a DTCS Quick Start kit and T7 and SP6 sequencing primers. Phred and Gap4 were used to analyze sequence reads generated by the CEQ 8000 and assemble them into a single contiguous sequence, from which a consensus sequence was calculated.

Data Analysis. Distinct sequence haplotypes were identified from the complete set of sequences using standard UNIX command line tools. DNASP (Rozas et al. 2003) was used to identify and calculate the numbers of synonymous and nonsynonymous (i.e., amino acid changing) polymorphisms. The nucleotide diversities (π) in each of the four samples were computed using the "ape" package within R (R Development Core Team 2007). The "boot" package within R was used to estimate 95% confidence intervals for π , based on 10,000 bootstrap resamplings of sequences within samples. A minimum-spanning network of the haplotypes was computed using TCS (Clement et al. 2000). The homogeneity of haplotype frequencies among the samples was tested by a Fisher exact test using R. An analysis of molecular variance (AMOVA) was performed using Arlequin (Excoffier et al. 2005) to compute F_{ST} , the fraction of the total genetic variance partitioned between populations and to test its significance by permutation. The AMOVA approach considers not only the frequencies of haplotypes in each sample but also the genetic distances between the haplotypes themselves.

Results

Six hundred forty-five base pairs of the ND1 gene were sequenced from each of 87 *S. albicosta*. Nine polymorphic nucleotide sites were identified, producing nine distinct sequence haplotypes. The sequence of each haplotype, labeled I-IX, was deposited with GenBank (accession numbers EU805541-EU805549), as was the corresponding ND1 sequence from *A. ipsilon* (accession number EU805550). Two of the polymorphic sites were predicted to produce polymorphisms in the amino acid sequence of NADH dehydrogenase I. A polymorphism at nucleotide position 40 predicted a methionine/threonine polymorphism, and a polymorphism at nucleotide position 634 predicted a phenylalanine/tyrosine polymorphism.

Construction of a minimum-spanning network (Fig. 2) showed that haplotype V was the closest haplotype

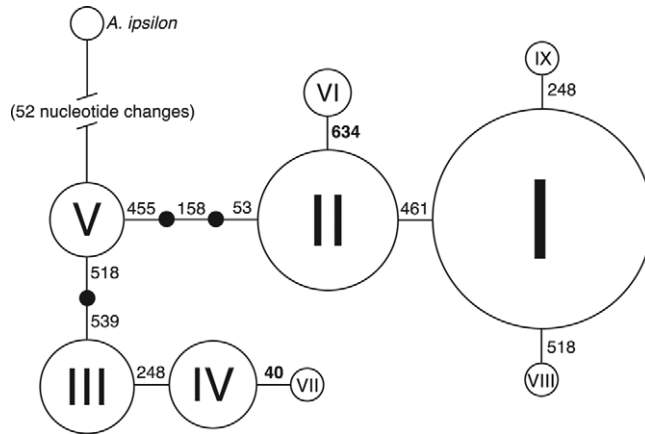

Fig. 2. Minimum spanning network of nine western bean cutworm mitochondrial ND1 haplotypes plus the orthologous sequence from *Agrotis ipsilon*. Branch labels indicate the nucleotide position at which the haplotypes differ. Nucleotide differences producing amino acid differences in the ND1 gene product are indicated in bold.

to the sequence from *A. ipsilon*, separated by 52 nucleotide differences. Single nucleotide changes were responsible for most of the differences between haplotypes in the network with the exception of the differences between haplotype V and II (three changes), and V and III (two changes). Homoplasies, or recurrent mutations, were identified at two nucleotide sites. Mutations at position 248 separated haplotypes I and IX and also haplotypes III and IV. Mutations at position 518 separated haplotypes I and VIII and also haplotypes III and V.

The frequencies of the nine haplotypes in each of the four samples are shown in Table 1. A Fisher exact test did not show any significant heterogeneity in haplotype frequencies among the samples ($P = 0.347$). In contrast, AMOVA did detect a modest ($F_{ST} = 0.061$) but significant ($P = 0.039$) genetic heterogeneity among the samples. Performing AMOVAs for each pair of samples in turn (Table 2) showed that this heterogeneity was caused by differences between the samples from Audubon and Goshen counties and Audubon and Iowa counties. Although the AMOVA for Audubon and Dawson counties did not indicate significant heterogeneity, the value of F_{ST} was the highest of any of the nonsignificant analyses. Nucleotide diversities were comparable between the four samples, with overlapping 95% confidence intervals (Fig. 3) and ranged from 0.0017 (Audubon) to 0.0051 (Iowa).

Table 1. Frequencies of mitochondrial ND1 haplotypes in four western bean cutworm populations

Haplotype	Goshen	Dawson	Audubon	Iowa
I	10	11	16	7
II	2	6	4	6
III	3	2		3
IV	2	1	1	3
V	2	2		1
VI			1	1
VII				1
VIII			1	
IX	1			

Discussion

Population bottlenecks have a characteristic effect on genetic diversity, reducing variation and causing rapid changes in gene frequencies (Miura 2007, Dlugosch and Parker 2008). In the context of the western bean cutworm, a bottleneck associated with the start of the current range expansion would result in new populations, east of the Missouri river, being less diverse than established populations to the west, and in divergent gene frequencies between the two population groups. This study did not find evidence for a reduction in diversity in younger western bean cutworm populations or divergent gene frequencies. Thus, the data from the mitochondrial DNA region studied here do not support the hypothesis of a substantial and recent bottleneck.

The apparent lack of a genetic bottleneck could imply that western bean cutworm populations have been established in Iowa for some time but that they have only recently increased to sufficient densities to become noticeable. This, however, would mean that populations have been increasing in a “wave” from west to east, which would be difficult to explain. A simpler explanation is that the species has begun to spread eastwards in numbers sufficient to avoid substantial genetic bottlenecks. This being the case, the question arises as to why western bean cutworm was largely confined to the west of the Missouri river throughout the latter half of the 20th century. It is

Table 2. AMOVA results for pairs of western bean cutworm populations based on mitochondrial ND1 sequence data

	Goshen	Dawson	Audubon	Iowa
Goshen		0.472	0.021	0.613
Dawson	-0.015		0.095	0.227
Audubon	0.134	0.057		0.005
Iowa	-0.027	0.019	0.198	

Lower triangle, estimates of F_{ST} , upper triangle: P values based on permutation.

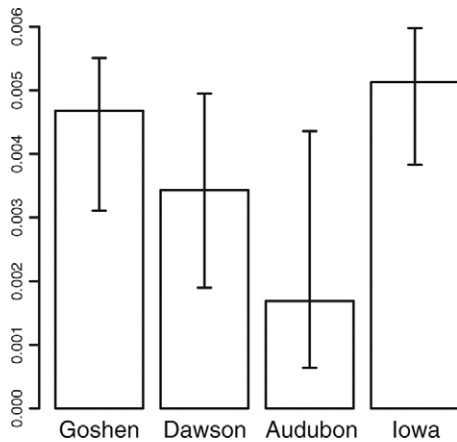

Fig. 3. Nucleotide diversity (π) and its 95% bootstrap confidence interval for part of the mitochondrial ND1 gene in four western bean cutworm populations.

striking that the range expansion began only a few years after the introduction of transgenic corn hybrids expressing insecticidal proteins derived from *Bacillus thuringiensis* (*Bt*), suggesting the possibility of a causal link between the two events. Catangui and Berg (2006) reported that western bean cutworms in South Dakota were able to infest transgenic corn hybrids expressing the *Bt* toxin Cry1Ab. These hybrids were first commercialized in 1996, primarily for the control of European corn borer, and have been widely adopted by U.S. corn farmers (Brookes and Barfoot 2006, Sivasupramaniam et al. 2007). Thus, the introduction of these hybrids could have opened up corn habitat to the western bean cutworm from which it was previously excluded by the use of synthetic insecticides applied to control European corn borer. This seems unlikely to be the primary factor, however, because only 26–27% of corn growers applied insecticides for European corn borer control before the introduction of *Bt* corn (Pilcher and Rice 1998, Pilcher et al. 2002).

It is also possible that the introduction of *Bt*-transgenic hybrids that are not toxic to western bean cutworm has allowed the species to escape from interspecific competition. Catangui and Berg (2006) reported that, on nontransgenic corn in South Dakota, western bean cutworms and European corn borers rarely infested the same plant and that European corn borer was the dominant species. They hypothesized that the recent spread of western bean cutworm and its growing impact as a corn pest may be the result of reduced interspecific competition with European corn borer because of the widespread adoption of transgenic hybrids that express Cry1Ab. In contrast, it should be noted that O'Rourke and Hutchinson (2000) found western bean cutworms infesting Cry1Ab-expressing and nontransgenic corn hybrids at similar rates in Minnesota despite European corn borers being present on the nontransgenic plants. Experimental studies of intraguild competition in the laboratory have shown that *S. albicosta* larvae are better

able to compete with the aggressive larvae of *Helicoverpa zea* (Boddie) when they are feeding together on Cry1Ab-expressing corn silks compared with the silks of nontransgenic isolate (Dorhout 2007). The results reported here are compatible with hypotheses that invoke a role of *Bt*-transgenic corn in promoting the western bean cutworm's current range expansion. Clearly, further studies of the interspecific interactions between *Bt* corn, western bean cutworm larvae, and those of other corn-feeding Lepidoptera will be important in clarifying their role in the western bean cutworm's present range expansion.

Although exact tests did not identify any significant differences in haplotype frequencies among the samples considered in this study, AMOVA detected a weak but significant genetic differentiation between the sample from Audubon county, IA, and those from Iowa county, IA, and Goshen county, WY. A key difference between the two analyses is that AMOVA incorporates information about the genetic distances between haplotypes in addition to variation in haplotype frequencies between samples (Excoffier et al. 1992). It is unclear whether the significance of the AMOVA result is meaningful given that the population in Audubon county was first detected in 2003 (Rice 2003), and genetic divergence caused by the accumulation of new mutations in the population is unlikely over such a short time scale. Indeed, this result may be an artifact of the modest sample sizes (≤ 23 individuals per sample).

Nevertheless, the AMOVA result may indicate that there is some weak genetic structuring of the western bean cutworm population in the Corn Belt that cannot be detected easily using mitochondrial DNA haplotype frequencies. The results of monitoring the spread of western bean cutworm with pheromone traps (M.E.R., unpublished data, available at <http://www.ent.iastate.edu/trap/westernbeancutworm/>) suggest that the range expansion often involves isolated outbreak populations establishing to the east of the main species distribution. This pattern of "stratified dispersal" is often seen during range expansions and can greatly increase the rate at which new territory is occupied (Liebhold and Tobin 2008). It is possible that founder effects associated with the establishment of the disconnected outbreaks may produce transient genetic heterogeneity that is rapidly eroded by subsequent migration as the outbreak populations rejoin with the main population. Determining whether this is the case will require careful sampling, particularly directed toward new outbreaks.

Mitochondrial DNA is undoubtedly a useful tool for studying variation in uncharacterized genomes because there are many universal PCR primers available that work with a wide range of taxa (Simon et al. 1994, 2006). However, the mitochondrial genome constitutes a single genetic locus and may not be representative of the genome as a whole. Multiple markers from the nuclear genome would be an important resource for obtaining a broader picture of the population genetics of western bean cutworm. Obtaining large numbers of highly variable nuclear markers may prove

challenging in the case of this species. Microsatellites have become the mostly widely used DNA-based genetic marker system for studies of population and ecological genetics in nonmodel organisms (Behura 2006, Selkoe and Toonen 2006). This popularity is largely because microsatellites are typically highly variable and easy to assay by PCR. However, developing microsatellites from Lepidoptera is notoriously problematic because loci with highly similar flanking regions are often duplicated throughout the genome, possibly because of the movement of mobile genetic elements (Meglec et al. 2004, Van't Hof et al. 2007). A more reliable source of genetic markers in Lepidoptera is likely to be nucleotide polymorphisms within expressed gene sequences (Coates et al. 2008).

Acknowledgments

We thank M. Minner and E. Testroet for providing technical assistance in the laboratory. Two anonymous reviewers provided constructive comments on an earlier draft of the manuscript.

References Cited

- Behura, S. K. 2006. Molecular marker systems in insects: current trends and future avenues. *Mol. Ecol.* 15: 3087–3113.
- Blickenstaff, C. C., and P. M. Jolley. 1982. Host plants of western bean cutworm. *Environ. Entomol.* 11: 421–425.
- Bonfield, J. K., K. F. Smith, and R. Staden. 1995. A new DNA sequence assembly program. *Nucleic Acids Res.* 23: 4992–4999.
- Brookes, G., and P. Barfoot. 2006. Global impact of biotech crops: socio-economic and environmental effects in the first ten years of commercial use. *AgBioForum* 9: 139–151.
- Catangui, M. A., and R. K. Berg. 2006. Western bean cutworm, *Striacosta albicosta* (Smith) (Lepidoptera: Noctuidae), as a potential pest of transgenic Cry1Ab *Bacillus thuringiensis* corn hybrids in South Dakota. *Environ. Entomol.* 35: 1439–1452.
- Clement, M., D. Posada, and K. A. Crandall. 2000. TCS: a computer program to estimate gene genealogies. *Mol. Ecol.* 9: 1657–1659.
- Coates, B. S., D. V. Sumerford, R. L. Hellmich, and L. C. Lewis. 2008. Mining an *Ostrinia nubilalis* midgut expressed sequence tag (EST) library for candidate genes and single nucleotide polymorphisms (SNPs). *Insect Mol. Biol.* DOI: 10.1111/j.1365-2583.2008.00-833.X.
- Cullen, E., and J. Jyuotika. 2008. Western bean cutworm: a pest of field and sweet corn. A3856, University of Wisconsin-Extension, Cooperative Extension. (<http://learningstore.uwex.edu/pdf/A3856.pdf>).
- DiFonzo, C. D., and R. Hammond. 2008. Range expansion of western bean cutworm, *Striacosta albicosta* (Noctuidae), into Michigan and Ohio. *Crop management*. DOI: 10.1094/CM-2008-0519-01-BR.
- Dlugosch, K. M., and I. M. Parker. 2008. Founding events in species invasions: genetic variation, adaptive evolution, and the role of multiple introductions. *Molec. Ecol.* 17: 431–449.
- Dorhout, D. L. 2007. Ecological and behavioral studies of the western bean cutworm (Lepidoptera: Noctuidae) in corn. MS thesis, Iowa State University, Ames, IA.
- Dorhout, D. L., and M. E. Rice. 2004. First report of western bean cutworm, *Richia albicosta* (Noctuidae) in Illinois and Missouri. *Crop management*. DOI: 10.1094/CM-2004-1229-01-BR.
- Dorhout, D. L., and M. E. Rice. 2008. An evaluation of western bean cutworm pheromone trapping techniques (Lepidoptera: Noctuidae) in a corn and soybean agroecosystem. *J. Econ. Entomol.* 101: 404–408.
- Douglass, J. R., J. W. Ingram, K. E. Gibson, and W. E. Peay. 1957. The western bean cutworm as a pest of corn in Idaho. *J. Econ. Entomol.* 50: 543–545.
- Ewing, B., and P. Green. 1998. Base-calling of automated sequencer traces using phred. II. Error probabilities. *Genome Res.* 8: 186–94.
- Ewing, B., L. Hillier, M. C. Wendl, and P. Green. 1998. Base-calling of automated sequencer traces using phred. I. Accuracy assessment. *Genome Res.* 8: 175–85.
- Excoffier, L., P. E. Smouse, and J. M. Quattro. 1992. Analysis of molecular variance inferred from metric distances among DNA haplotypes: application to human mitochondrial DNA restriction data. *Genetics* 131: 479–491.
- Excoffier, L., G. Laval, and S. Schneider. 2005. Arlequin (version 3.0): an integrated software package for population genetics data analysis. *Evol. Bioinform. Online* 1: 47–50.
- Hagen, A. F. 1962. The biology and control of the western bean cutworm in dent corn in Nebraska. *J. Econ. Entomol.* 55: 628–631.
- Hagen, A. F. 1963. Evaluation of populations and control of the western bean cutworm in field beans in Nebraska. *J. Econ. Entomol.* 56: 222–224.
- Hagen, A. F. 1976. A fourteen year summary of light trap catches of the western bean cutworm in Nebraska *Loxagrotis albicosta* (Smith) (Lepidoptera: Noctuidae). *J. Kans. Entomol. Soc.* 49: 537–541.
- Hoerner, J. L. 1948. The cutworm *Loxagrotis albicosta* on beans. *J. Econ. Entomol.* 41: 631–635.
- Liebholt, A. M., and P. C. Tobin. 2008. Population ecology of insect invasions and their management. *Annu. Rev. Entomol.* 53: 387–408.
- Marcon, P., D. Taylor, C. Mason, R. Hellmich, and B. Siegfried. 1999. Genetic similarity among pheromone and voltinism races of *Ostrinia nubilalis* (Hubner) (Lepidoptera: Crambidae). *Insect Mol. Biol.* 8: 213–221.
- Meglec, E., F. Petenian, E. Danchin, A. C. D'Acier, J. Rasplus, and E. Faure. 2004. High similarity between flanking regions of different microsatellites detected within each of two species of Lepidoptera: *Parnassius apollo* and *Euphydryas aurinia*. *Molec. Ecol.* 13: 1693–1700.
- Miura, O. 2007. Molecular genetic approaches to elucidate the ecological and evolutionary issues associated with biological invasions. *Ecol. Res.* 22: 876–883.
- O'Rourke, P. K., and W. D. Hutchinson. 2000. First report of the western bean cutworm, *Richia albicosta* (Smith) (Lepidoptera: Noctuidae) in Minnesota corn. *J. Agric. Urban Entomol.* 17: 213–217.
- Pilcher, C. D., and M. E. Rice. 1998. Management of European corn borer (Lepidoptera: Crambidae) and corn rootworms (Coleoptera: Chrysomelidae) with transgenic corn: a survey of farmer perceptions. *Am. Entomol.* 44: 36–44.
- Pilcher, C. D., M. E. Rice, R. A. Higgins, K. L. Steffey, R. L. Hellmich, J. Witkowski, D. Calvin, K. R. Ostlie, and M. Gray. 2002. Biotechnology and the European corn borer: measuring historical farmer perceptions and adoption of transgenic Bt corn as a pest management strategy. *J. Econ. Entomol.* 95: 878–892.
- Pope, R. 2007. Western bean cutworm management in 2006. Iowa State University Extension Service, Ames, IA.

- R Development Core Team. 2007.** R: a language and environment for statistical computing. R Foundation for Statistical Computing, Vienna, Austria.
- Rice, M. E. 2000.** Western bean cutworm hits northwest Iowa. Iowa State University Extension Service, Ames, IA.
- Rice, M. E. 2003.** Scout now for western bean cutworms. Iowa State University Extension Service, Ames, IA.
- Rice, M. E., and C. Pilcher. 2007.** Regional pest alert: western bean cutworm, *Striacosta albicosta* (Smith). (http://www.ncipmc.org/alerts/wbc_alert.pdf).
- Rice, M. E., D. Dorhout, and R. Pope. 2004.** Eastern movement of the western bean cutworm (http://www.ent.iastate.edu/dept/faculty/rice/rice_wbc2004.pdf).
- Rozas, J., J. C. Sanchez-DelBarrio, X. Messeguer, and R. Rozas. 2003.** DnaSP, DNA polymorphism analyses by the coalescent and other methods. *Bioinformatics* 19: 2496–2497.
- Rozen, S., and H. Skaletsky. 2000.** Primer3 on the WWW for general users and for biologist programmers, pp. 365–386. *In* S. Krawetz and S. Misener (eds.), *Bioinformatics methods and protocols: methods in molecular biology*. Humana Press, Totowa, NJ.
- Selkoe, K. A., and R. J. Toonen. 2006.** Microsatellites for ecologists: a practical guide to using and evaluating microsatellite markers. *Ecol. Lett.* 9: 615–629.
- Seymour, R. C., G. L. Hein, R. J. Wright, and J. B. Campbell. 1998.** Western bean cutworm in corn and dry beans. (<http://www.ianrpubs.unl.edu/sendIt/g1359.pdf>).
- Simon, C., F. Frati, A. Beckenbach, B. Crespi, H. Liu, and P. Flook. 1994.** Evolution, weighting, and phylogenetic utility of mitochondrial gene sequences and a compilation of conserved polymerase chain reaction primers. *Ann. Entomol. Soc. Am.* 87: 651–701.
- Simon, C., T. Buckley, F. Frati, J. Stewart, and A. Beckenbach. 2006.** Incorporating molecular evolution into phylogenetic analysis, and a new compilation of conserved polymerase chain reaction primers for animal mitochondrial DNA. *Annu. Rev. Ecol. Evol. Syst.* 37: 545–579.
- Sivasupramaniam, S., G. P. Head, L. English, Y. J. Li, and T. T. Vaughn. 2007.** A global approach to resistance monitoring. *J. Invertebr. Pathol.* 95: 224–226.
- Van't Hof, A. E., P. M. Brakefield, I. J. Saccheri, and B. J. Zwaan. 2007.** Evolutionary dynamics of multilocus microsatellite arrangements in the genome of the butterfly *Bicyclus anynana*, with implications for other Lepidoptera. *Heredity* 98: 320–328.

Received 6 August 2008; accepted 26 September 2008.