

University of Nebraska - Lincoln

DigitalCommons@University of Nebraska - Lincoln

Nebraska Tractor Tests

Tractor Test and Power Museum, The Lester F.
Larsen

January 2007

Test 1900: New Holland TG 215 Diesel 19-Speed

Tractor Museum

University of Nebraska-Lincoln, TractorMuseumArchives@unl.edu

Follow this and additional works at: <https://digitalcommons.unl.edu/tractormuseumlit>



Part of the [Applied Mechanics Commons](#)

Museum, Tractor, "Test 1900: New Holland TG 215 Diesel 19-Speed" (2007). *Nebraska Tractor Tests*. 2077.

<https://digitalcommons.unl.edu/tractormuseumlit/2077>

This Article is brought to you for free and open access by the Tractor Test and Power Museum, The Lester F. Larsen at DigitalCommons@University of Nebraska - Lincoln. It has been accepted for inclusion in Nebraska Tractor Tests by an authorized administrator of DigitalCommons@University of Nebraska - Lincoln.

NEBRASKA OECD TRACTOR TEST 1900—SUMMARY 567

NEW HOLLAND TG 215 DIESEL

19 SPEED

POWER TAKE-OFF PERFORMANCE

Power HP (kW)	Crank shaft speed rpm	Gal/hr (l/h)	lb/hp.hr (kg/kW.h)	Hp.hr/gal (kW.h/l)	Mean Atmospheric Conditions
MAXIMUM POWER AND FUEL CONSUMPTION					
Rated Engine Speed—(PTO speed—1109 rpm)					
177.89 (132.65)	2200	11.64 (44.07)	0.459 (0.279)	15.28 (3.01)	
Standard Power Take-off Speed (1008 rpm)					
213.41 (159.14)	2000	13.41 (50.76)	0.441 (0.268)	15.91 (3.14)	
Maximum Power (1 hour)					
213.73 (159.38)	1800	12.97 (49.09)	0.425 (0.259)	16.48 (3.25)	

VARYING POWER AND FUEL CONSUMPTION

177.89 (132.65)	2200	11.64 (44.07)	0.459 (0.279)	15.28 (3.01)	Air temperature
154.70 (115.36)	2247	11.20 (42.38)	0.507 (0.309)	13.82 (2.72)	79°F (26°C)
117.39 (87.54)	2274	10.08 (38.17)	0.602 (0.366)	11.64 (2.29)	Relative humidity
80.02 (59.67)	2329	7.83 (29.64)	0.686 (0.417)	10.22 (2.01)	57%
40.86 (30.47)	2368	5.93 (22.46)	1.018 (0.619)	6.89 (1.36)	Barometer
1.50 (1.12)	2406	3.78 (14.31)	17.562 (10.738)	0.40 (0.08)	28.60" Hg (96.90 kPa)

Maximum torque - 673 lb.-ft. (913 Nm) at 1502 rpm

Maximum torque rise - 58.5%

Torque rise at 1800 engine rpm - 47%

Power increase at 1800 engine rpm - 20.1%

DRAWBAR PERFORMANCE

UNBALLASTED - FRONT DRIVE ENGAGED FUEL CONSUMPTION CHARACTERISTICS

Power Hp (kW)	Drawbar pull lbs (kN)	Speed mph (km/h)	Crank- shaft speed rpm	Slip %	Fuel Consumption		Temp. °F (°C)		Barom. inch Hg (kPa)
					lb/hp.hr (kg/kW.h)	Hp.hr/gal (kW.h/l)	cool- ing med	Air dry bulb	
Maximum Power—7th Gear									
154.64 (115.32)	13296 (59.14)	4.36 (7.02)	2197	3.40	0.529 (0.322)	13.25 (2.61)	187 (86)	66 (19)	29.05 (98.37)
75% of Pull at Maximum Power—7th Gear									
120.64 (89.96)	9981 (44.40)	4.53 (7.29)	2258	2.31	0.631 (0.384)	11.11 (2.19)	187 (86)	73 (23)	29.03 (98.31)
50% of Pull at Maximum Power—7th Gear									
82.59 (61.59)	6650 (29.58)	4.66 (7.50)	2299	1.41	0.760 (0.462)	9.23 (1.82)	185 (85)	73 (23)	29.03 (98.31)
75% of Pull at Reduced Engine Speed—9th Gear									
120.44 (89.81)	9921 (44.13)	4.55 (7.33)	1714	2.29	0.533 (0.324)	13.15 (2.59)	184 (84)	73 (23)	29.03 (98.31)
50% of Pull at Reduced Engine Speed—9th Gear									
82.44 (61.48)	6643 (29.55)	4.65 (7.49)	1736	1.36	0.597 (0.363)	11.75 (2.32)	179 (82)	74 (23)	29.03 (98.31)

Location of tests: Nebraska Tractor Test Laboratory, University of Nebraska, Lincoln, Nebraska 68583-0832

Dates of tests: May 4 - 18, 2007

Manufacturer: CNH America LLC, 700 State St. Racine, Wi. 53404 USA

FUEL, OIL and TIME: Fuel No. 2 Diesel Specific gravity converted to 60°/60°F (15°/15°C) 0.8432 Fuel weight 7.011 lbs/gal (0.840 kg/l) Oil SAE 15W40 API service classification CI-4 Transmission and hydraulic lubricant New Holland Multi-Tran fluid Front axle lubricant SAE 85W-140 API GL-5 Total time engine was operated: 23.5 hours

ENGINE: Make CNH Engine Corporation Diesel **Type** six cylinder vertical with turbocharger and air to air intercooler **Serial No.** *46699645* **Crankshaft** lengthwise **Rated engine speed** 2200 **Bore and stroke** 4.488" x 5.315" (114.0 mm x 135.0 mm) **Compression ratio** 17.5 to 1 **Displacement** 505 cu in (8268 ml) **Starting system** 12 volt **Lubrication** pressure **Air cleaner** two paper elements and aspirator **Oil filter** one full flow cartridge **Oil cooler** engine coolant heat exchanger for crankcase oil, radiator for hydraulic and transmission oil **Fuel filter** two paper elements **Fuel cooler** radiator for pump return fuel **Muffler** vertical **Cooling medium temperature control** 2 thermostats and variable speed fan

ENGINE OPERATING PARAMETERS: Fuel rate: 77.4-85.3 lb/h (35.1 - 38.7 kg/h) **High idle:** 2380-2420 rpm **Turbo boost:** nominal 19.6 - 23.9 psi (135 - 165 kPa) as measured 20.4 psi (141 kPa)

CHASSIS: Type front wheel assist **Serial No.** *Z7RW01444* **Tread width** rear 64.0" (1626 mm) to 129.0" (3277 mm) front 60.0" (1524 mm) to 88.0" (2235 mm) **Wheelbase** 129.3" (3284 mm) **Hydraulic control system** direct engine drive **Transmission** selective gear fixed ratio with full range operator controlled powershift **Nominal travel speeds mph (km/h)** first 1.97 (3.17) second 2.26 (3.64) third 2.60 (4.19) fourth 2.99 (4.81) fifth 3.43 (5.52) sixth 3.93 (6.33) seventh 4.59 (7.38) eighth 5.26 (8.47) ninth 6.06 (9.77) tenth 6.96 (11.20) eleventh 7.98 (12.85) twelfth 9.16 (14.74) thirteenth 11.41 (18.37) fourteenth 13.09 (21.07) fifteenth 15.10 (24.30) sixteenth 17.32 (27.87) seventeenth 19.87 (31.97) eighteenth 22.79 (36.67) nineteenth 24.86 (40.00) (1900 engine rpm) reverse 2.83 (4.56), 3.26 (5.24), 6.61 (10.63), 7.57 (12.19) **Clutch** multiple wet disc electrohydraulically operated by foot pedal **Brakes** wet disc hydraulically operated by two foot pedals that can be locked together **Steering** hydrostatic **Power take-off** 540 rpm at 1988 engine rpm or 1000 rpm at 1984 engine rpm **Unladen tractor mass** 21150 lb (9593 kg)

DRAWBAR PERFORMANCE
UNBALLASTED - FRONT DRIVE ENGAGED
MAXIMUM POWER IN SELECTED GEARS

Power Hp (kW)	Drawbar pull lbs (kN)	Speed mph (km/h)	Crank- shaft speed rpm	Slip %	Fuel Consumption lb/hp.hr (kg/kW.h)	Fuel Consumption Hp.hr/gal (kW.h/l)	Temp. °F cool- ing med	Temp. °C Air dry bulb	Barom. inch Hg (kPa)
3rd Gear									
125.02 (93.23)	20257 (90.11)	2.31 (3.72)	2245	11.68	0.632 (0.385)	11.09 (2.18)	186 (86)	53 (12)	29.06 (98.41)
4th Gear									
142.93 (106.58)	19615 (87.25)	2.73 (4.40)	2229	8.44	0.571 (0.348)	12.27 (2.42)	186 (86)	58 (14)	29.06 (98.41)
5th Gear									
154.40 (115.14)	18737 (83.34)	3.09 (4.97)	2175	7.50	0.549 (0.334)	12.78 (2.52)	187 (86)	63 (17)	29.06 (98.41)
6th Gear									
169.14 (126.13)	18376 (81.74)	3.45 (5.55)	2101	6.75	0.546 (0.332)	12.83 (2.53)	187 (86)	63 (17)	29.06 (98.41)
7th Gear									
180.85 (134.86)	17581 (78.20)	3.86 (6.21)	1999	6.10	0.523 (0.318)	13.41 (2.64)	188 (86)	68 (20)	29.05 (98.37)
8th Gear									
182.01 (135.73)	17042 (75.80)	4.01 (6.45)	1802	5.71	0.502 (0.305)	13.97 (2.75)	187 (86)	69 (21)	29.05 (98.37)
9th Gear									
183.37 (136.74)	14655 (65.19)	4.69 (7.55)	1802	4.20	0.496 (0.302)	14.13 (2.78)	187 (86)	70 (21)	29.05 (98.37)
10th Gear									
184.02 (137.23)	12698 (56.48)	5.43 (8.75)	1802	3.29	0.496 (0.302)	14.13 (2.78)	188 (86)	71 (22)	29.04 (98.34)
11th Gear									
182.87 (136.36)	10927 (48.61)	6.28 (10.10)	1802	2.63	0.499 (0.303)	14.06 (2.77)	186 (86)	71 (22)	29.04 (98.34)
12th Gear									
181.49 (135.34)	9420 (41.90)	7.22 (11.63)	1801	2.19	0.503 (0.306)	13.93 (2.74)	187 (86)	71 (22)	29.04 (98.34)
13th Gear									
180.33 (134.47)	7465 (33.20)	9.06 (14.58)	1802	1.67	0.507 (0.308)	13.83 (2.72)	187 (86)	71 (22)	29.04 (98.34)

REPAIRS AND ADJUSTMENTS: No repairs or adjustments.

REMARKS: All test results were determined from observed data obtained in accordance with official OECD, SAE and Nebraska test procedures. For the maximum power tests the fuel temperature at the primary fuel filter was maintained at 103°F (40°C). The pull in 2nd gear (ballasted tractor) was limited to avoid excessive tractor bouncing. The performance results on this summary were taken from OECD tests conducted under the Code II Test Code Procedure.

We, the undersigned, certify that this is a true and correct report of official Tractor Test No. **1900**, Nebraska Summary 567, August 20, 2007.

Roger M. Hoy
 Director

M.F. Kocher
 V.I. Adamchuk
 J.A. Smith
 Board of Tractor Test Engineers

TRACTOR SOUND LEVEL WITH CAB	dB(A)
At no load in 7th gear	72.9
Bystander in 18th gear	87.2

TIRES, BALLAST AND WEIGHT

	With Ballast	Without Ballast
Rear Tires -No., size, ply & psi (kPa)	Four 520/85R42;**,10(70)	Two 520/85R42;**,17(115)
Ballast - Duals (total)	1950 lb (885 kg)	None
- Cast Iron (total)	None	None
Front Tires -No., size, ply & psi (kPa)	Two 420/90R30;**,16(110)	Two 420/90R30;**,15(105)
Ballast - Liquid (total)	None	None
- Cast Iron (total)	1010 lb (458 kg)	None
Height of Drawbar	18.0 in (455 mm)	17.5 in (445 mm)
Static Weight with operator - Rear	15760 lb (7149 kg)	13840 lb (6278 kg)
- Front	8525 lb (3867 kg)	7485 lb (3395 kg)
- Total	24285 lb (11016 kg)	21325 lb (9673 kg)

DRAWBAR PERFORMANCE
BALLASTED - 1800 ENGINE RPM
MAXIMUM POWER IN SELECTED GEARS

Power Hp (kW)	Drawbar pull lbs (kN)	Speed mph (km/h)	Crank- shaft speed rpm	Slip %	Fuel Consumption lb/hp.hr (kg/kW.h)	Consumption Hp.hr/gal (kW.h/l)	Temp. °F cool- ing med	°C Air dry bulb	Barom. inch Hg (kPa)
2nd Gear									
130.99 (97.68)	24009 (106.80)	2.05 (3.29)	2242	9.50	0.608 (0.370)	11.53 (2.27)	186 (86)	51 (11)	29.12 (98.61)
3rd Gear									
148.20 (110.51)	23436 (104.25)	2.37 (3.82)	2206	7.57	0.551 (0.335)	12.73 (2.51)	186 (86)	54 (12)	29.12 (98.61)
4th Gear									
163.47 (121.90)	23277 (103.54)	2.63 (4.24)	2129	7.28	0.539 (0.328)	13.02 (2.56)	187 (86)	57 (14)	29.12 (98.61)
5th Gear									
176.63 (131.71)	23049 (102.53)	2.87 (4.62)	2017	6.92	0.530 (0.322)	13.22 (2.61)	187 (86)	58 (14)	29.12 (98.61)
6th Gear									
180.46 (134.57)	21355 (94.90)	3.17 (5.10)	1902	5.39	0.512 (0.312)	13.68 (2.70)	187 (86)	58 (14)	29.13 (98.65)
7th Gear									
183.98 (137.19)	19432 (86.44)	3.55 (5.71)	1803	3.88	0.493 (0.300)	14.21 (2.80)	187 (86)	59 (15)	29.13 (98.65)
8th Gear									
185.55 (138.36)	16926 (75.29)	4.11 (6.62)	1804	3.07	0.488 (0.297)	14.37 (2.83)	187 (86)	60 (16)	29.13 (98.65)
9th Gear									
185.73 (138.50)	14597 (64.93)	4.77 (7.68)	1805	2.42	0.489 (0.297)	14.35 (2.83)	187 (86)	60 (16)	29.13 (98.65)
10th Gear									
184.38 (137.49)	12602 (56.06)	5.49 (8.83)	1802	2.00	0.494 (0.301)	14.19 (2.80)	187 (86)	60 (16)	29.13 (98.65)
11th Gear									
180.88 (134.88)	10736 (47.76)	6.32 (10.17)	1803	1.67	0.502 (0.305)	13.96 (2.75)	187 (86)	61 (16)	29.13 (98.65)
12th Gear									
180.29 (134.44)	9289 (41.32)	7.28 (11.71)	1804	1.35	0.503 (0.306)	13.93 (2.74)	187 (86)	61 (16)	29.13 (98.65)
13th Gear									
176.02 (131.26)	7265 (32.32)	9.09 (14.62)	1803	1.02	0.515 (0.314)	13.60 (2.68)	187 (86)	61 (16)	29.14 (98.68)

THREE POINT HITCH PERFORMANCE(OECD Static Test)

CATEGORY: III

Quick Attach: Yes

Maximum force exerted through whole range: 14070 lb (62.6 kN) High Lift Option
16375 lb (72.8 kN)

i) Sustained pressure at compensator cutoff: 3140 psi (216 bar) Mega flow pump
2949 psi (203 bar)

ii) Pump delivery rate at minimum pressure and rated engine speed: 39.4 GPM (149.1 l/min) 31.4 GPM (118.9 l/min)
 Combined flow: 70.8 GPM (268.0 l/min)

iii) Pump delivery rate at maximum hydraulic power: 37.9 GPM (143.5 l/min) 31.9 GPM (120.8 l/min)
 Delivery pressure: 2852 psi (197 bar) 2705 psi (186 bar)
 Power: 63.1 HP (47.0 kW) 50.3 Hp (37.5 kW)

HITCH DIMENSIONS AS TESTED—NO LOAD

	inch	mm
A	28.2	718
B	20.5	520
C	22.9	581
D	20.7	525
E	10.5	266
F	15.7	400
G	36.4	925
H	3.5	90
I	20.9	530
J	20.7	525
K	30.2	768
L	46.1	1170
*L'	50.7	1287
M	20.1	511
N	38.2	970
O	9.0	230
P	47.6	1210
Q	40.7	1035
R	39.2	995

*L' to Quick Attach ends

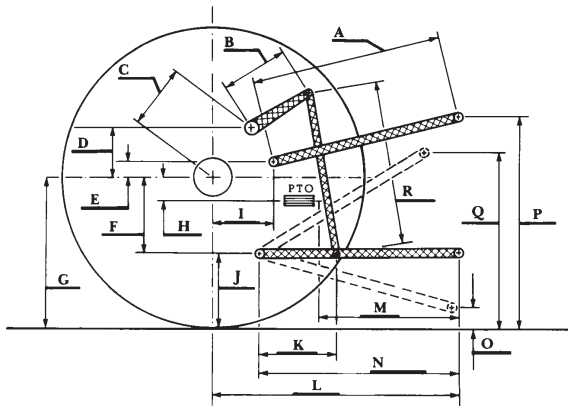

NEW HOLLAND TG215 DIESEL