

University of Nebraska - Lincoln

DigitalCommons@University of Nebraska - Lincoln

Nebraska Tractor Tests

Tractor Test and Power Museum, The Lester F.
Larsen

2017

Tractor Test 2173: John Deere 9570RX Diesel

Nebraska Tractor Test Laboratory

Follow this and additional works at: <https://digitalcommons.unl.edu/tractormuseumlit>



Part of the [Energy Systems Commons](#), [History of Science, Technology, and Medicine Commons](#), [Other Mechanical Engineering Commons](#), [Physical Sciences and Mathematics Commons](#), [Science and Mathematics Education Commons](#), and [the United States History Commons](#)

This Article is brought to you for free and open access by the Tractor Test and Power Museum, The Lester F. Larsen at DigitalCommons@University of Nebraska - Lincoln. It has been accepted for inclusion in Nebraska Tractor Tests by an authorized administrator of DigitalCommons@University of Nebraska - Lincoln.

NEBRASKA OECD TRACTOR TEST 2173-SUMMARY 1087

JOHN DEERE 9570RX DIESEL

18 SPEED

POWER TAKE-OFF PERFORMANCE

Power HP (kW)	Crank shaft speed rpm	Diesel Consumption		D.E.F. Consumption		Mean Atmospheric Conditions
		Gal/hr (l/h)	lb/hp.hr (kg/kW.h)	Hp.hr/gal (kW.h/l)	Gal/hr (l/h)	
MAXIMUM POWER AND FUEL CONSUMPTION						
SEE NOTE 3 - PAGE 2						
Rated Engine Speed—(PTO speed—1108 rpm)						
320.42 (238.94)	2099	19.68 (74.50)	0.430 (0.262)	16.28 (3.21)	0.95 (3.58)	Fuel used during active exhaust regeneration-1.56 gal (5.92 l) (see note 2, p.2)
Standard Power Take-off Speed(1000 rpm)						
347.67 (259.26)	1895	19.97 (75.61)	0.402 (0.245)	17.41 (3.43)	0.91 (3.44)	
Maximum Power (1 hour)						
355.97 (265.45)	1650	19.22 (72.74)	0.378 (0.230)	18.52 (3.65)	0.98 (3.71)	

VARYING POWER AND FUEL CONSUMPTION

320.42 (238.94)	2099	19.68 (74.50)	0.430 (0.262)	16.28 (3.21)	0.95 (3.58)	Air temperature
279.08 (208.11)	2151	18.08 (68.43)	0.454 (0.276)	15.44 (3.04)	0.89 (3.36)	74°F (23°C)
209.41 (156.16)	2150	14.86 (56.25)	0.497 (0.302)	14.09 (2.78)	0.71 (2.69)	Relative humidity
139.67 (104.15)	2150	11.82 (44.76)	0.593 (0.361)	11.81 (2.33)	0.57 (2.14)	54%
69.85 (52.09)	2151	8.90 (33.70)	0.893 (0.543)	7.85 (1.55)	0.32 (1.22)	Barometer
1.35 (1.01)	2150	6.28 (23.77)	32.613 (19.838)	0.21 (0.04)	0.20 (0.74)	28.81" Hg (97.55 kPa)

Maximum Torque - 1173 lb-ft (1591 Nm) at 1499 rpm
 Maximum Torque Rise -46.4%
 Torque rise at 1681 engine rpm - 38%
 Power increase at 1650 engine rpm - 11.1%

DRAWBAR PERFORMANCE (Unballasted) FUEL CONSUMPTION CHARACTERISTICS

Power Hp (kW)	Drawbar pull lbs (kN)	Speed mph (km/h)	Crank- shaft speed rpm	Slip %	Fuel Consumption lb/hp.hr (kg/kW.h)	D.E.F. Consumption Hp.hr/gal (kW.h/l)	D.E.F. Consumption lb/hp.hr (kg/kW.h)	Temp. °F (°C) cool- ing med	Air dry bulb	Barom. inch Hg (kPa)
Power at Rated Engine Speed—7th Gear- Manual mode										
446.57 (333.00)	33904 (150.81)	4.94 (7.95)	2100	4.1	0.447 (0.272)	15.67 (3.09)	0.022 (0.013)	209 (98)	72 (22)	28.76 (97.39)
75% of Pull at Rated Engine Speed—7th Gear- Manual mode										
353.74 (263.78)	25413 (113.04)	5.22 (8.40)	2173	2.1	0.457 (0.278)	15.32 (3.02)	0.025 (0.015)	208 (98)	53 (11)	28.73 (97.29)
50% of Pull at Rated Engine Speed—7th Gear- Manual mode										
241.53 (180.11)	16944 (75.37)	5.35 (8.60)	2201	0.9	0.508 (0.309)	13.78 (2.72)	0.032 (0.019)	204 (95)	47 (8)	28.80 (97.53)
75% of Pull at Reduced Engine Speed—5.3 mph (8.6 km/h)-Auto mode										
353.40 (263.53)	25471 (113.30)	5.20 (8.37)	1584	2.0	0.404 (0.246)	17.32 (3.41)	0.030 (0.018)	206 (97)	51 (11)	28.76 (97.39)
50% of Pull at Reduced Engine Speed—5.5 mph (8.8 km/h)-Auto mode										
240.97 (179.69)	16787 (74.67)	5.38 (8.66)	1318	0.9	0.423 (0.258)	16.54 (3.26)	0.025 (0.015)	187 (86)	45 (7)	28.81 (97.56)

Location of tests: Nebraska Tractor Test Laboratory, University of Nebraska, Lincoln, Nebraska 68583-0832

Dates of tests: April 7 - 19, 2017

Manufacturer: John Deere Tractor Works, 3500 East Donald St., P.O. Box 270, Waterloo Ia, 50704-0270

CONSUMABLE Fluids, OIL and TIME: Fuel No. 2 Diesel **Specific gravity converted to 60°/60°F (15°/15°C)** 0.8411 **Fuel weight** 7.003 lbs/gal (0.839 kg/l) **Diesel Exhaust Fluid (DEF)** 32% aqueous urea solution **DEF weight** 9.071 lbs/gal (1.087 kg/l) **Oil SAE 10W-30 API service classification** CJ-4 **Transmission, hydraulic and final drive lubricant** John Deere Hy-Gard fluid **Total time engine was operated:** 30.0 hours

ENGINE: Make Cummins **Diesel Type** six cylinder vertical with turbocharger, air to air aftercooler and D.E.F. (diesel exhaust fluid) exhaust treatment **Serial No.** *79941720* **Crankshaft** lengthwise **Rated engine speed** 2100 **Bore and stroke** 5.394" x 6.654" (137.0 mm x 169.0 mm) **Compression ratio** 17.2 to 1 **Displacement** 912 cu in (14948 ml) **Starting system** 12 volt **Lubrication** pressure **Air cleaner** two paper elements and aspirator **Oil filter** one full flow cartridge **Oil cooler** engine coolant heat exchanger for crankcase oil, radiator for transmission/hydraulic oil also feeding front and rear axles **Fuel filter** two paper cartridges **Fuel cooler** radiator for returned fuel **Exhaust** DOC (diesel oxidation catalyst), SCR (selective catalyst reduction) and regenerative DPF (diesel particulate filter) integrated within a vertical muffler **Cooling medium temperature control** thermostat and variable speed fan

ENGINE OPERATING PARAMETERS: Fuel rate: Stationary PTO operation (395 engine hp) 137.3 - 148.8 lb/h (62.3 - 67.5 kg/h), Drawbar operations (570 engine hp) 189.0 - 204.1 lb/h (85.7 - 92.6 kg/h) **High idle:** 2215 - 2265 rpm (2125 - 2175 rpm with PTO engaged) **Turbo boost:** (570 engine hp) nominal 26.8 - 29.7 psi (185 - 205 kPa) as measured 28.0 psi (193 kPa)

CHASSIS: Type 4WD with rubber tracks **Serial No.** *1RW9570RHGP801561* **Track width** rear 88.0" (2235 mm) front 88.0" (2235 mm) **Wheelbase** 163.5" (4154 mm) **Length of track on ground** 72.4" (1839 mm) **Hydraulic control system** direct engine drive **Transmission** selective gear fixed ratio with full range operator controlled power shift **Nominal travel speeds mph (km/h)** first 2.50 (4.03) second 3.08 (4.96) third 3.41 (5.48) fourth 3.81 (6.13) fifth 4.19 (6.75) sixth 4.69 (7.55) seventh 5.18 (8.34) eighth 5.76 (9.27) ninth 6.38 (10.27) tenth 7.09 (11.41) eleventh 7.84 (12.61) twelfth 8.71 (14.02) thirteenth 9.64 (15.52) fourteenth 10.73 (17.26)

DRAWBAR PERFORMANCE
(Unballasted at 2100 engine rpm, Manual mode)

MAXIMUM POWER IN SELECTED GEARS

Power Hp (kW)	Drawbar pull lbs (kN)	Speed mph (km/h)	Crank-shaft speed rpm	Slip %	Fuel Consumption lb/hp.hr (kg/kW.h)	Hp.hr/gal (kW.h/l)	D.E.F Consumption lb/hp.hr (kg/kW.h)	Temp. °F(°C) cool- ing med	Air dry bulb	Barom. inch Hg (kPa)
					2nd Gear					
359.42 (268.02)	48424 (215.40)	2.78 (4.47)	2103	9.3	0.478 (0.291)	14.64 (2.88)	0.026 (0.016)	206 (97)	51 (11)	29.05 (98.37)
					3rd Gear					
381.17 (284.23)	46771 (208.05)	3.06 (4.92)	2103	9.7	0.471 (0.287)	14.87 (2.93)	0.025 (0.015)	206 (97)	57 (14)	29.06 (98.41)
					4th Gear					
420.90 (313.87)	45874 (204.06)	3.45 (5.54)	2100	9.0	0.470 (0.286)	14.90 (2.94)	0.022 (0.013)	210 (99)	55 (13)	28.71 (97.22)
					5th Gear					
433.36 (323.16)	41816 (186.00)	3.89 (6.26)	2100	6.8	0.452 (0.275)	15.48 (3.05)	0.021 (0.013)	209 (98)	56 (13)	28.68 (97.12)
					6th Gear					
437.73 (326.42)	37145 (165.23)	4.42 (7.11)	2100	5.1	0.457 (0.278)	15.33 (3.02)	0.022 (0.013)	210 (99)	71 (22)	28.75 (97.36)
					7th Gear					
446.57 (333.00)	33904 (150.81)	4.94 (7.95)	2100	4.1	0.447 (0.272)	15.67 (3.09)	0.022 (0.013)	209 (98)	72 (22)	28.76 (97.39)
					8th Gear					
446.68 (333.09)	30191 (134.29)	5.55 (8.93)	2100	2.9	0.444 (0.270)	15.78 (3.11)	0.021 (0.013)	208 (98)	69 (20)	28.81 (97.56)
					9th Gear					
447.40 (333.62)	27119 (120.63)	6.19 (9.95)	2099	2.3	0.445 (0.271)	15.73 (3.10)	0.022 (0.013)	210 (99)	70 (21)	28.72 (97.26)
					10th Gear					
444.98 (331.82)	24158 (107.46)	6.91 (11.12)	2100	1.9	0.446 (0.271)	15.70 (3.09)	0.022 (0.013)	209 (98)	70 (21)	28.79 (97.49)
					11th Gear					
445.62 (332.30)	21798 (96.96)	7.67 (12.34)	2100	1.5	0.446 (0.271)	15.69 (3.09)	0.022 (0.013)	209 (98)	71 (22)	28.79 (97.49)
					12th Gear					
445.55 (332.24)	19546 (86.94)	8.55 (13.76)	2099	1.2	0.447 (0.272)	15.66 (3.09)	0.022 (0.014)	208 (98)	72 (22)	28.77 (97.43)

fifteenth 13.26 (21.34) sixteenth 16.32 (26.26) seventeenth 20.04 (32.25) eighteenth 24.67 (39.70) reverse 2.50 (4.03), 3.41 (5.48), 3.81 (6.13), 5.18 (8.34), 5.76 (9.27), 7.84 (12.61) **Clutch** wet multiple disc hydraulically actuated by foot pedal **Brakes** wet multiple disc hydraulically actuated by foot pedal **Steering** hydrostatic and articulated **Power take-off** 1000 rpm at 1895 engine rpm **Unladen tractor mass** 57420 lb (26045 kg)

REPAIRS AND ADJUSTMENTS: No repairs or adjustments.

NOTE 1: This tractor has a driveline protection system that limits the maximum engine torque in gears 1 through 3.

NOTE 2. The manufacturer declares that the average time between active regenerations is 60 hours.

NOTE 3. In stationary PTO operation, this model operates in a derated power mode. With stationary PTO operation, using FieldCruise™, an isochronous governor is utilized. All PTO tests were conducted with FieldCruise™ engaged.

REMARKS: All test results were determined from observed data obtained in accordance with official OECD, SAE and Nebraska test procedures. The performance figures on this summary were taken from a test conducted under the OECD Code 2 test procedure.

We, the undersigned, certify that this is a true and correct report of official Tractor Test No. **2173**, Nebraska Summary 1087, June 12, 2017.

Roger M. Hoy
Director

M.F. Kocher
P.J. Jasa
S.K. Pitla
Board of Tractor Test Engineers

TRACTOR SOUND LEVEL WITH CAB

dB(A)

At no load in 6th gear	72.0
Transport speed- no load- 18th gear	74.7
Bystander in 17th gear	89.7

TRACKS AND WEIGHT

Rear tracks - no & size
Front tracks - no & size
Height of drawbar
Static weight with operator- Rear
- Front
- Total

Tested Without Ballast

2 x 30.0 in (760 mm)
2 x 30.0 in (760 mm)
21.0 in (545 mm)
25600 lb (11612 kg)
31995 lb (14513 kg)
57595 lb (26125 kg)

DRAWBAR PERFORMANCE
UNBALLASTED - AUTO MODE
(Loads based on 2100 engine rpm manual mode performance runs)
DRAWBAR POWER AT SELECTED TRAVEL SPEEDS

Power Hp (kW)	Drawbar pull lbs (kN)	Speed mph (km/h)	Crank- shaft speed rpm	Slip %	Fuel Consumption		D.E.F. Consumption	Temp.°F (°C)	Air dry bulb	Barom. inch Hg (kPa)
					lb/hp.hr (kg/kW.h)	Hp.hr/gal (kW.h/l)	lb/hp.hr (kg/kW.h)	cool- ing med		
4.7 mph (7.6 km/h)										
437.97 (326.59)	36838 (163.86)	4.46 (7.17)	1723	5.1	0.419 (0.255)	16.70 (3.29)	0.027 (0.016)	209 (98)	70 (21)	28.73 (97.29)
5.2 mph (8.4 km/h)										
446.93 (333.28)	33651 (149.69)	4.98 (8.01)	1719	4.2	0.417 (0.254)	16.79 (3.31)	0.027 (0.017)	209 (98)	72 (22)	28.74 (97.33)
5.7 mph (9.2 km/h)										
446.47 (332.93)	30412 (135.28)	5.51 (8.86)	1695	3.1	0.414 (0.252)	16.90 (3.33)	0.028 (0.017)	208 (98)	69 (21)	28.81 (97.56)
6.3 mph (10.2 km/h)										
446.76 (333.15)	27242 (121.18)	6.15 (9.90)	1699	2.3	0.414 (0.252)	16.93 (3.34)	0.028 (0.017)	210 (99)	70 (21)	28.71 (97.22)
7.1 mph (11.4 km/h)										
444.50 (331.46)	24128 (107.32)	6.91 (11.12)	1708	1.9	0.412 (0.251)	17.00 (3.35)	0.028 (0.017)	208 (98)	71 (21)	28.79 (97.49)
7.8 mph (12.6 km/h)										
445.45 (332.17)	21796 (96.95)	7.66 (12.33)	1705	1.5	0.417 (0.253)	16.81 (3.31)	0.028 (0.017)	209 (98)	71 (22)	28.78 (97.46)
8.7 mph (14.0 km/h)										
445.68 (332.34)	19546 (86.94)	8.55 (13.76)	1706	1.2	0.412 (0.251)	17.00 (3.35)	0.028 (0.017)	209 (98)	72 (22)	28.76 (97.39)

DRAWBAR PERFORMANCE
(Unballasted at 1800 ENGINE RPM, Manual mode)
MAXIMUM POWER IN SELECTED GEARS

Power Hp (kW)	Drawbar pull lbs (kN)	Speed mph (km/h)	Crank- shaft speed rpm	Slip %	Fuel Consumption lb/hp.hr (kg/kW.h)	Hp.hr/gal (kW.h/l)	D.E.F Consumption lb/hp.hr (kg/kW.h)	Temp.°F(°C) cool- ing med	Air dry bulb	Barom. inch Hg (kPa)
					2nd Gear					
361.96 (269.91)	53140 (236.38)	2.56 (4.11)	2035	13.9	0.495 (0.301)	14.15 (2.79)	0.026 (0.016)	206 (97)	54 (12)	29.06 (98.40)
					3rd Gear					
390.03 (290.84)	50343 (223.94)	2.91 (4.68)	2052	12.2	0.476 (0.289)	14.72 (2.90)	0.024 (0.015)	206 (97)	55 (13)	29.06 (98.40)
					4th Gear					
422.52 (315.07)	48188 (214.35)	3.29 (5.29)	2064	11.8	0.477 (0.290)	14.69 (2.89)	0.022 (0.013)	207 (97)	57 (14)	29.07 (98.44)
					5th Gear					
445.41 (332.12)	46641 (207.47)	3.59 (5.77)	2020	10.8	0.462 (0.281)	15.15 (2.98)	0.022 (0.013)	208 (98)	59 (15)	29.06 (98.40)
					6th Gear					
463.41 (345.56)	44777 (199.18)	3.89 (6.25)	1930	9.5	0.454 (0.276)	15.42 (3.04)	0.021 (0.013)	208 (98)	59 (15)	29.06 (98.40)
					7th Gear					
483.68 (360.68)	42594 (189.47)	4.26 (6.86)	1871	7.2	0.435 (0.265)	16.09 (3.17)	0.022 (0.013)	209 (98)	56 (14)	28.66 (97.05)
					8th Gear					
495.55 (369.53)	40413 (179.77)	4.60 (7.39)	1800	6.2	0.426 (0.259)	16.46 (3.24)	0.022 (0.014)	210 (99)	56 (13)	28.68 (97.12)
					9th Gear					
498.73 (371.90)	36074 (160.47)	5.19 (8.34)	1800	4.6	0.423 (0.258)	16.54 (3.26)	0.022 (0.013)	210 (99)	55 (13)	28.65 (97.02)
					10th Gear					
502.51 (374.72)	32378 (144.02)	5.82 (9.37)	1799	3.5	0.420 (0.255)	16.69 (3.29)	0.022 (0.014)	209 (98)	55 (13)	28.64 (96.99)
					11th Gear					
503.58 (375.52)	29140 (129.62)	6.48 (10.43)	1800	2.8	0.417 (0.254)	16.79 (3.31)	0.022 (0.013)	209 (98)	55 (13)	28.65 (97.02)
					12th Gear					
509.53 (379.95)	26358 (117.24)	7.25 (11.67)	1800	2.2	0.415 (0.253)	16.86 (3.32)	0.022 (0.013)	209 (98)	56 (13)	28.67 (97.09)
					13th Gear					
501.71 (374.13)	23312 (103.69)	8.07 (12.99)	1801	1.8	0.422 (0.257)	16.60 (3.27)	0.022 (0.013)	209 (98)	57 (14)	28.65 (97.02)

Lugging ability in 11th gear

Crankshaft speed rpm	2100	2000	1900	1800	1700	1600	1400	1104
Pull-lbs (kN)	21590 (96.04)	24875 (110.65)	27007 (120.13)	29043 (129.19)	30557 (135.92)	31487 (140.06)	31111 (138.39)	27878 (124.01)
Increase in pull%	0	15	25	35	42	46	44	29
Power-Hp (kW)	440.60 (328.56)	481.90 (358.75)	494.32 (368.61)	501.75 (374.15)	497.14 (370.72)	481.28 (358.89)	416.60 (310.65)	296.11 (220.81)
Speed-mph (km/h)	7.65 (12.31)	7.25 (11.67)	6.86 (11.04)	6.48 (10.43)	6.10 (9.82)	5.73 (9.22)	5.03 (8.09)	3.98 (6.41)
Slip %	1.7	2.1	2.5	2.9	3.2	3.3	3.2	2.8

HYDRAULIC PERFORMANCE

CATEGORY: 4N/4

Quick Attach: Yes

OECD Static test

Maximum force exerted through whole range:

Category 4N lift cylinders
 15648 lbs(69.6 kN) (1 x 90 mm and 1x100 mm)
 20965 lbs(93.3 kN) (2 x 110 mm)

Category 4
 15501 lbs(69.0 kN) (1 x 90 mm and 1x100 mm)
 20527 lbs(91.3 kN) (2 x 110 mm)

Base pump Tandem pump
three outlet sets combined

i) Sustained pressure at compensator cutoff:

2974 psi (205 bar) 2933 psi (202 bar)

ii) Pump delivery rate at minimum pressure and rated engine speed:

60.5 GPM (228.9 l/min) 56.9 GPM (215.4 l/min)

Combined flow:

117.4 GPM (444.3 l/min)

iii) Pump delivery rate at maximum

hydraulic power:

61.5 GPM (232.9 l/min) 57.2 GPM (216.5 l/min)

Delivery pressure:

2533 psi (175 bar) 2403 psi (166 bar)

Power:

90.9 HP (67.8 kW) 80.2 HP (59.8 kW)

single outlet set

3/4" couplers

1/2" couplers

i) Sustained pressure at compensator cutoff:

2856 psi (197 bar) 2969 psi (205 bar)

ii) Pump delivery rate at minimum pressure and rated engine speed:

43.1 GPM (163.2 l/min) 36.6 GPM (138.4 l/min)

iii) Pump delivery rate at maximum

hydraulic power:

42.5 GPM (160.9 l/min) 35.5 GPM (134.5 l/min)

Delivery pressure:

2226 psi (153 bar) 2249 psi (155 bar)

Power:

55.2 HP (41.2 kW) 46.6 HP (34.7 kW)

Category 4N

inch mm

	inch	mm	inch	mm
A	30.7	780	29.9	760
B	19.7	500	19.7	500
C	34.8	885	34.8	885
D	28.7	730	28.7	730
E	18.7	475	18.7	475
F	12.5	318	12.5	318
G	33.1	842	33.1	842
*G'	19.5	495	19.5	495
H	2.2	57	2.2	57
I	28.8	733	28.8	733
J	20.6	524	20.6	524
K	30.9	785	30.9	785
L	52.8	1342	52.8	1342
*L'	58.7	1491	59.6	1515
M	14.7	374	14.7	374
N	45.6	1159	45.6	1159
O	9.0	230	9.0	230
P	47.6	1210	47.6	1210
Q	40.6	1032	40.4	1027
R	49.6	1260	48.6	1260

*G' to undercarriage pivot point

*L' to Quick Attach ends

HITCH DIMENSIONS AS TESTED—NO LOAD

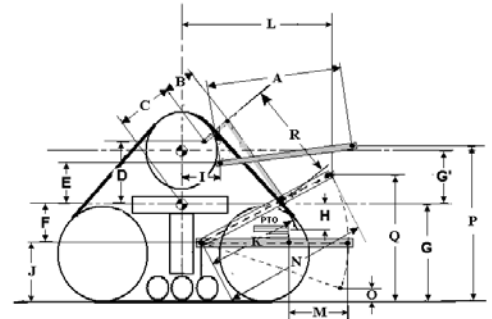

JOHN DEERE 9570RX DIESEL