

University of Nebraska - Lincoln

DigitalCommons@University of Nebraska - Lincoln

Nebraska Tractor Tests

Tractor Test and Power Museum, The Lester F.
Larsen

2008

Test 1924: John Deere 9530 Diesel

Nebraska Tractor Test Laboratory

University of Nebraska-Lincoln, tractortestlab@unl.edu

Follow this and additional works at: <https://digitalcommons.unl.edu/tractormuseumlit>



Part of the [Energy Systems Commons](#), [History of Science, Technology, and Medicine Commons](#), [Other Mechanical Engineering Commons](#), [Physical Sciences and Mathematics Commons](#), [Science and Mathematics Education Commons](#), and the [United States History Commons](#)

Laboratory, Nebraska Tractor Test, "Test 1924: John Deere 9530 Diesel" (2008). *Nebraska Tractor Tests*. 2308.

<https://digitalcommons.unl.edu/tractormuseumlit/2308>

This Article is brought to you for free and open access by the Tractor Test and Power Museum, The Lester F. Larsen at DigitalCommons@University of Nebraska - Lincoln. It has been accepted for inclusion in Nebraska Tractor Tests by an authorized administrator of DigitalCommons@University of Nebraska - Lincoln.

NEBRASKA OECD TRACTOR TEST 1924–SUMMARY 594

JOHN DEERE 9530 DIESEL

18 SPEED

DRAWBAR PERFORMANCE (Unballasted) FUEL CONSUMPTION CHARACTERISTICS

Power Hp (kW)	Drawbar pull lbs (kN)	Speed mph (km/h)	Crank- shaft speed rpm	Slip %	Fuel Consumption lb/hp.hr (kg/kW.h)	Fuel Consumption Hp.hr/gal (kW.h/l)	Temp.°F (°C) cool- ing med	Air dry bulb	Barom. inch Hg (kPa)
Maximum Power—7th Gear									
390.59 (291.26)	30065 (133.73)	4.87 (7.84)	2099	3.2	0.443 (0.270)	15.74 (3.10)	199 (93)	70 (21)	28.98 (98.14)
75% of Pull at Maximum Power—7th Gear									
304.52 (227.08)	22549 (100.30)	5.06 (8.15)	2168	2.4	0.484 (0.294)	14.42 (2.84)	198 (92)	71 (22)	28.86 (97.73)
50% of Pull at Maximum Power—7th Gear									
207.22 (154.53)	15074 (67.05)	5.16 (8.30)	2193	1.8	0.550 (0.335)	12.68 (2.50)	183 (84)	75 (24)	28.85 (97.70)
75% of Pull at Reduced Engine Speed—10th Gear									
305.37 (227.71)	22684 (100.90)	5.05 (8.12)	1581	2.5	0.461 (0.280)	15.14 (2.98)	204 (96)	72 (22)	28.86 (97.73)
50% of Pull at Reduced Engine Speed—10th Gear									
207.12 (154.45)	15063 (67.00)	5.16 (8.30)	1602	1.7	0.501 (0.305)	13.93 (2.74)	199 (93)	76 (24)	28.85 (97.70)

Lugging ability in 11th gear

Crankshaft speed rpm	2099	1998	1907	1803	1696	1606	1206	1107
Pull-lbs (kN)	19306 (85.88)	22584 (100.46)	24370 (108.40)	26023 (115.76)	26963 (119.94)	27665 (123.06)	28314 (125.95)	28203 (125.45)
Increase in pull%	0	17	26	35	40	43	47	46
Power-Hp (kW)	383.67 (286.10)	425.04 (316.95)	437.13 (325.97)	440.96 (328.83)	429.58 (320.34)	416.85 (310.84)	320.05 (238.66)	291.44 (217.33)
Speed-mpg (km/h)	7.45 (11.99)	7.06 (11.36)	6.73 (10.83)	6.35 (10.23)	5.97 (9.62)	5.65 (9.09)	4.24 (6.82)	3.88 (6.24)
Slip %	2.2	2.5	2.7	2.9	3.1	3.3	3.5	3.5

Location of tests: Nebraska Tractor Test Laboratory, University of Nebraska, Lincoln, Nebraska 68583-0832

Dates of tests: October 29 - November 13, 2008

Manufacturer: John Deere Tractor Works, 3500 East Donald St., P.O. Box 270, Waterloo Ia, 50704-0270

FUEL, OIL and TIME: Fuel No. 2 Diesel Specific gravity converted to 60°/60°F (15°/15°C) 0.8380 Fuel weight 6.977 lbs/gal (0.836 kg/l) Oil SAE 15W-40 API service classification CJ-4 Transmission, hydraulic and final drive lubricant John Deere Hy-Gard fluid Total time engine was operated: 24.5 hours

ENGINE: Make John Deere Diesel **Type** six cylinder vertical with turbocharger and air to air aftercooler **Serial No.** *RG6135L001554* **Crankshaft** lengthwise **Rated engine speed** 2100 **Bore and stroke** 5.197" x 6.496" (132.0 mm x 165.0 mm) **Compression ratio** 16.0 to 1 **Displacement** 826 cu in (13548 ml) **Starting system** 12 volt **Lubrication** pressure **Air cleaner** two paper elements and aspirator **Oil filter** one full flow cartridge **Oil cooler** engine coolant heat exchanger for crankcase oil, radiator for hydraulic and transmission oil, radiator for front and rear axle oil **Fuel filter** two paper cartridges **Fuel cooler** radiator for returned fuel **Muffler** vertical **Cooling medium temperature control** 3 thermostats and variable speed fan

ENGINE OPERATING PARAMETERS: Fuel rate: (425 engine hp) 144.0 - 155.6 lb/h (65.3 - 70.6 kg/h), (450 engine hp) 153.5 - 166.1 lb/h (69.6 - 75.3 kg/h), (475 engine hp) 160.4 - 173.7 lb/h (72.8 - 78.8 kg/h) **High idle:** 2215 - 2265 rpm **Turbo boost:** (475 engine hp) nominal 29.7 - 33.4 psi (205 - 230 kPa) as measured 30.5 psi (210 kPa)

CHASSIS: Type four wheel drive with triples **Serial No.** *RW9530P002230* **Tread width** rear 57.5" (1460 mm) to 163.8" (4160 mm) front 57.5" (1460 mm) to 163.8" (4160 mm) **Wheelbase** 137.7" (3498 mm) **Hydraulic control system** direct engine drive **Transmission** selective gear fixed ratio with full range operator controlled power shift **Nominal travel speeds mph (km/h)** first 2.42 (3.89) second 2.98 (4.79) third 3.29 (5.30) fourth 3.68 (5.92) fifth 4.05 (6.52) sixth 4.52 (7.28) seventh 5.01 (8.06) eighth 5.59 (9.00) ninth 6.16 (9.92) tenth 6.89 (11.08) eleventh 7.62 (12.27) twelfth 8.43 (13.56) thirteenth 9.38 (15.10) fourteenth 10.37 (16.69) fifteenth 12.82 (20.63) sixteenth 15.77 (25.38) seventeenth 19.50 (31.38) eighteenth 24.00 (38.62) reverse 2.42 (3.89), 3.29 (5.30), 3.68 (5.92), 5.01 (8.06), 5.59 (9.00), 7.62 (12.27)

DRAWBAR PERFORMANCE

(Unballasted at 2100 rpm)

MAXIMUM POWER IN SELECTED GEARS

Power Hp (kW)	Drawbar pull lbs (kN)	Speed mph (km/h)	Crank- shaft speed rpm	Slip %	Fuel Consumption lb/hp.hr (kg/kW.h)	Temp.°F (°C) cool- ing med	Temp.°F (°C) Air dry bulb	Barom. inch Hg (kPa)	
2nd Gear									
319.17 (238.01)	42405 (188.62)	2.82 (4.54)	2132	8.9	0.481 (0.293)	14.49 (2.86)	183 (84)	56 (13)	29.07 (98.44)
3rd Gear									
338.94 (252.75)	40820 (181.58)	3.11 (5.01)	2100	7.4	0.460 (0.280)	15.16 (2.99)	183 (84)	54 (12)	29.07 (98.44)
4th Gear									
355.47 (265.07)	38032 (169.17)	3.50 (5.64)	2099	5.7	0.460 (0.280)	15.18 (2.99)	183 (84)	52 (11)	28.91 (97.90)
5th Gear									
383.57 (286.03)	37103 (165.04)	3.88 (6.24)	2100	5.0	0.450 (0.274)	15.51 (3.06)	187 (86)	56 (13)	28.90 (97.87)
6th Gear									
382.20 (285.01)	32762 (145.73)	4.37 (7.04)	2099	3.8	0.452 (0.275)	15.43 (3.04)	199 (93)	70 (21)	28.98 (98.14)
7th Gear									
390.59 (291.26)	30065 (133.73)	4.87 (7.84)	2099	3.2	0.443 (0.270)	15.74 (3.10)	199 (93)	70 (21)	28.98 (98.14)
8th Gear									
390.37 (291.10)	26988 (120.05)	5.42 (8.73)	2099	3.0	0.444 (0.270)	15.72 (3.10)	199 (93)	69 (21)	28.98 (98.14)
9th Gear									
387.59 (289.02)	24100 (107.20)	6.03 (9.71)	2101	2.7	0.445 (0.271)	15.67 (3.09)	196 (91)	68 (20)	28.98 (98.14)
10th Gear									
385.09 (287.16)	21451 (95.42)	6.73 (10.83)	2099	2.4	0.450 (0.273)	15.52 (3.06)	200 (93)	67 (19)	28.98 (98.14)
11th Gear									
383.67 (286.10)	19306 (85.88)	7.45 (11.99)	2099	2.2	0.450 (0.274)	15.50 (3.05)	202 (94)	70 (21)	28.98 (98.14)
12th Gear									
387.66 (289.07)	17559 (78.10)	8.28 (13.32)	2099	2.0	0.447 (0.272)	15.62 (3.08)	204 (96)	71 (22)	28.97 (98.10)

Clutch wet multiple disc hydraulically actuated by foot pedal **Brakes** wet multiple disc hydraulically actuated foot pedal **Steering** hydrostatic and articulated **Power take-off** none **Unladen tractor mass** 39845 lb (18073 kg).

REPAIRS AND ADJUSTMENTS: No repairs or adjustments.

NOTE: The 9530 engine has an electronic control system which provides a vehicle protection system to avoid overloading the drive train. This system provides three different engine power levels. At 2100 rpm the engine produces up to 425 hp when the transmission is in forward gears 1 through 3. At 2100 rpm the engine produces 450 hp when the transmission is in gear 4. At 2100 rpm the engine produces 475 hp in all other applications.

REMARKS: All test results were determined from observed data obtained in accordance with official OECD, SAE and Nebraska test procedures. For the maximum power tests the fuel temperature at the primary fuel filter was maintained at 108°F (42°C). The pull in 3rd gear was limited to avoid excessive tractor bouncing. The performance figures on this summary were taken from a test conducted under the OECD Code II test code procedure.

We, the undersigned, certify that this is a true and correct report of official Tractor Test No. **1924**, Nebraska Summary 594, January 12, 2009.

Roger M. Hoy
Director

M.F. Kocher
V.I. Adamchuk
J.A. Smith
Board of Tractor Test Engineers

TRACTOR SOUND LEVEL WITH CAB

	dB(A)
At no load in 6th gear	73.5
Transport speed - no load - 18th gear	76.3
Bystander in 18th gear	90.4

TIRES, BALLAST AND WEIGHT

	With Ballast	Without Ballast
Rear Tires - No., size, ply & psi(kPa)	Six 480/80R46;***;12(85)	Six 480/80R46;***;10(70)
Ballast - Liquid (total)	None	None
- Cast Iron (total)	5190 lb (2354 kg)	None
Front Tires - No., size, ply & psi(kPa)	Six 480/80R46;***;15(105)	Six 480/80R46;***;12(85)
Ballast - Liquid (total)	None	None
- Cast Iron (total)	3520 lb (1597 kg)	None
Height of Drawbar	21.0 in (535 mm)	21.0 in (535 mm)
Static Weight with operator - Rear	21640 lb (9816 kg)	16450 lb (7462 kg)
- Front	27090 lb (12288 kg)	23570 lb (10691 kg)
- Total	48730 lb (22104 kg)	40020 lb (18153 kg)

DRAWBAR PERFORMANCE
(Unballasted at 1800 RPM)
MAXIMUM POWER IN SELECTED GEARS

Power Hp (kW)	Drawbar pull lbs (kN)	Speed mph (km/h)	Crank- shaft speed rpm	Slip %	Fuel Consumption lb/hp.hr (kg/kW.h)	Fuel Consumption Hp.hr/gal (kW.h/l)	Temp. °F(°C) cool- ing med	Air dry bulb	Barom. inch Hg (kPa)
3rd Gear									
341.37 (254.56)	42316 (188.23)	3.03 (4.87)	2074	9.6	0.464 (0.282)	15.03 (2.96)	183 (84)	52 (11)	29.07 (98.44)
4th Gear									
360.55 (268.86)	38743 (172.34)	3.49 (5.62)	2091	6.2	0.457 (0.278)	15.27 (3.01)	185 (85)	54 (12)	28.91 (97.90)
5th Gear									
390.55 (291.24)	38344 (170.56)	3.82 (6.15)	2079	5.9	0.450 (0.274)	15.51 (3.06)	189 (87)	57 (14)	28.90 (97.87)
6th Gear									
414.88 (309.38)	37667 (167.55)	4.13 (6.65)	2005	5.2	0.448 (0.273)	15.56 (3.07)	195 (90)	58 (14)	28.90 (97.87)
7th Gear									
433.32 (323.13)	36620 (162.89)	4.44 (7.14)	1947	5.1	0.438 (0.266)	15.93 (3.14)	200 (93)	60 (16)	28.89 (97.83)
8th Gear									
435.95 (325.09)	35764 (159.08)	4.57 (7.36)	1800	4.7	0.439 (0.267)	15.89 (3.13)	203 (95)	61 (16)	28.88 (97.80)
9th Gear									
436.85 (325.76)	31807 (141.48)	5.15 (8.29)	1807	3.8	0.438 (0.267)	15.92 (3.14)	203 (95)	63 (17)	28.88 (97.80)
10th Gear									
434.17 (323.76)	28524 (126.88)	5.71 (9.19)	1802	3.4	0.441 (0.269)	15.80 (3.11)	203 (95)	65 (18)	28.88 (97.80)
11th Gear									
435.63 (324.85)	25724 (114.42)	6.35 (10.22)	1803	2.8	0.438 (0.266)	15.93 (3.14)	203 (95)	66 (19)	28.88 (97.80)
12th Gear									
438.18 (326.75)	23235 (103.35)	7.07 (11.38)	1798	2.5	0.436 (0.265)	15.99 (3.15)	205 (96)	68 (20)	28.87 (97.77)
13th Gear									
430.27 (320.85)	20564 (91.47)	7.85 (12.63)	1801	2.3	0.443 (0.269)	15.75 (3.10)	203 (95)	69 (21)	28.87 (97.77)
14th Gear									
436.33 (325.37)	18724 (83.29)	8.74 (14.06)	1804	2.0	0.438 (0.266)	15.94 (3.14)	203 (95)	70 (21)	28.87 (97.77)

DRAWBAR PERFORMANCE
(Ballasted at 1800 RPM)
MAXIMUM POWER IN SELECTED GEARS

Power Hp (kW)	Drawbar pull lbs (kN)	Speed mph (km/h)	Crank- shaft speed rpm	Slip %	Fuel Consumption lb/hp.hr (kg/kW.h)	Temp. °F(°C) cool- ing med	Air dry bulb	Barom. inch Hg (kPa)	
307.31 (229.16)	50519 (224.72)	2.28 (3.67)	2146	9.5	1st Gear 0.493 (0.300)	14.14 (2.79)	183 (84)	46 (8)	28.40 (96.17)
351.61 (262.20)	49302 (219.30)	2.67 (4.30)	2014	6.9	2nd Gear 0.467 (0.284)	14.95 (2.95)	191 (88)	45 (7)	28.40 (96.17)
368.39 (274.71)	48079 (213.86)	2.87 (4.62)	1966	6.1	3rd Gear 0.456 (0.277)	15.30 (3.01)	183 (83)	43 (6)	28.76 (97.39)
400.17 (298.40)	47056 (209.32)	3.19 (5.13)	1936	5.5	4th Gear 0.449 (0.273)	15.53 (3.06)	185 (85)	44 (7)	28.75 (97.36)
428.52 (319.55)	45810 (203.77)	3.51 (5.65)	1925	4.9	5th Gear 0.441 (0.268)	15.81 (3.11)	189 (87)	44 (7)	28.74 (97.33)
431.67 (321.90)	43676 (194.28)	3.71 (5.96)	1801	4.3	6th Gear 0.444 (0.270)	15.72 (3.10)	197 (91)	44 (7)	28.74 (97.33)
443.23 (330.51)	40148 (178.59)	4.14 (6.66)	1803	4.1	7th Gear 0.433 (0.263)	16.13 (3.18)	196 (91)	45 (7)	28.73 (97.29)
445.40 (332.13)	36086 (160.52)	4.63 (7.45)	1804	3.8	8th Gear 0.431 (0.262)	16.18 (3.19)	198 (92)	46 (8)	28.72 (97.26)
441.73 (329.40)	32199 (143.23)	5.14 (8.28)	1801	3.3	9th Gear 0.435 (0.264)	16.05 (3.16)	200 (93)	46 (8)	28.71 (97.22)
437.50 (326.24)	28564 (127.06)	5.74 (9.24)	1800	2.8	10th Gear 0.435 (0.265)	16.03 (3.16)	207 (97)	45 (7)	28.40 (96.17)
437.88 (326.53)	25763 (114.60)	6.37 (10.26)	1802	2.5	11th Gear 0.435 (0.265)	16.04 (3.16)	203 (95)	45 (7)	28.40 (96.17)
438.21 (326.77)	23195 (103.18)	7.08 (11.40)	1801	2.2	12th Gear 0.433 (0.263)	16.12 (3.18)	205 (96)	44 (7)	28.40 (96.17)
432.15 (322.26)	20647 (91.84)	7.85 (12.63)	1798	2.0	13th Gear 0.439 (0.267)	15.89 (3.13)	207 (97)	43 (6)	28.40 (96.17)
434.11 (323.72)	18530 (82.43)	8.79 (14.14)	1804	1.6	14th Gear 0.438 (0.266)	15.92 (3.14)	206 (97)	42 (6)	28.40 (96.17)

HYDRAULIC PERFORMANCE

CATEGORY: IVN, IV

Quick Attach: yes

OECD Static test

Maximum Force exerted through whole range: 15677 lbs (69.7 kN)(Cat IVN)
15769 lbs (70.1 kN)(Cat IV)

i) Sustained pressure at compensator cutoff: 2918 psi (201 bar)
Single outlet set Three outlet sets combined

ii) Pump delivery rate at minimum pressure and rated engine speed: 38.6 GPM (146.2 l/min) 51.2 GPM (193.7 l/min)

iii) Pump delivery rate at maximum hydraulic power: 35.7 GPM (135.3 l/min) 50.4 GPM (190.9 l/min)
Delivery pressure: 2149 psi (148 bar) 2457 psi (169 bar)
Power: 44.8 Hp (33.4 kW) 72.3 HP (53.9 kW)

HITCH DIMENSIONS AS TESTED—NO LOAD

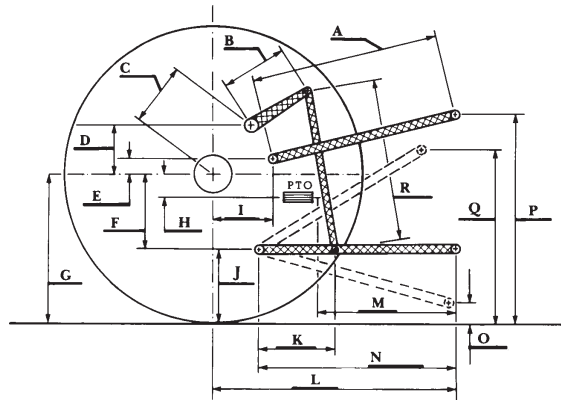

	Category IVN		Category IV	
	inch	mm	inch	mm
A	30.9	785	30.1	765
B	18.6	472	18.6	472
C	26.2	666	26.2	666
D	24.4	620	24.4	620
E	11.3	288	11.3	288
F	13.8	350	13.8	350
G	36.2	920	36.2	920
H	4.0	101	4.0	101
I	22.7	577	22.7	577
J	22.4	570	22.4	570
K	28.3	718	28.3	718
L	54.5	1385	55.3	1405
*L'	61.8	1570	62.6	1590
M	31.9	810	32.7	830
N	43.2	1097	44.0	1117
O	9.0	230	9.0	230
P	49.4	1256	49.4	1256
Q	41.5	1053	41.4	1052
R	43.7	1110	43.9	1115

*L' to Quick Attach ends



JOHN DEERE 9530 DIESEL