

University of Nebraska - Lincoln

DigitalCommons@University of Nebraska - Lincoln

---

Nebraska Tractor Tests

Tractor Test and Power Museum, The Lester F.  
Larsen

---

2012

## Test 2049: Case IH Steiger 600 Quadtrac

Nebraska Tractor Test Lab

University of Nebraska-Lincoln, tractortestlab@unl.edu

Follow this and additional works at: <https://digitalcommons.unl.edu/tractormuseumlit>



Part of the [Energy Systems Commons](#), [History of Science, Technology, and Medicine Commons](#), [Other Mechanical Engineering Commons](#), [Physical Sciences and Mathematics Commons](#), [Science and Mathematics Education Commons](#), and the [United States History Commons](#)

---

Nebraska Tractor Test Lab, "Test 2049: Case IH Steiger 600 Quadtrac" (2012). *Nebraska Tractor Tests*. 2473.

<https://digitalcommons.unl.edu/tractormuseumlit/2473>

This Article is brought to you for free and open access by the Tractor Test and Power Museum, The Lester F. Larsen at DigitalCommons@University of Nebraska - Lincoln. It has been accepted for inclusion in Nebraska Tractor Tests by an authorized administrator of DigitalCommons@University of Nebraska - Lincoln.

# NEBRASKA OECD TRACTOR TEST 2049 - SUMMARY 849

## CASE IH STEIGER 600 QUADTRAC DIESEL

### 16 SPEED

**Location of tests:** Nebraska Tractor Test Laboratory, University of Nebraska, Lincoln Nebraska 68583-0832

**Dates of tests:** November 15 - 19, 2012

**Manufacturer:** Case Corporation, 700 State Street Racine, Wi. 53404 USA.

#### POWER TAKE-OFF PERFORMANCE

Power HP (kW)	Crank shaft speed rpm	Diesel Consumption		D.E.F. Consumption		Mean Atmospheric Conditions
		Gal/hr (l/h)	lb/hp.hr (kg/kW.h)	Hp.hr/gal (kW.h/l)	Gal/hr (l/h)	
<b>MAXIMUM POWER AND FUEL CONSUMPTION</b>						
<b>Rated Engine Speed—(PTO speed—1051 rpm)</b>						
476.83 (355.57)	2100	26.34 (99.72)	0.387 (0.236)	18.10 (3.57)	2.14 (8.10)	
<b>Standard Power Take-off Speed (1000 rpm)</b>						
517.80 (386.12)	1998	27.65 (104.65)	0.374 (0.228)	18.73 (3.69)	2.13 (8.08)	
<b>Maximum Power (1 hour)</b>						
535.88 (399.61)	1900	27.94 (105.75)	0.365 (0.222)	19.18 (3.78)	2.14 (8.10)	

#### VARYING POWER AND FUEL CONSUMPTION

476.83 (355.57)	2100	26.34 (99.72)	0.387 (0.236)	18.10 (3.57)	2.14 (8.10)	Air temperature
414.40 (309.02)	2148	23.77 (89.96)	0.402 (0.244)	17.44 (3.43)	1.86 (7.02)	75°F (24°C)
312.80 (233.25)	2161	19.10 (72.29)	0.428 (0.260)	16.38 (3.23)	1.29 (4.87)	Relative humidity
209.20 (156.00)	2168	14.37 (54.38)	0.481 (0.293)	14.56 (2.87)	1.00 (3.79)	22%
104.60 (78.00)	2178	9.86 (37.34)	0.661 (0.402)	10.60 (2.09)	0.48 (1.82)	Barometer
2.60 (1.94)	2187	5.63 (21.32)	15.181 (9.234)	0.46 (0.09)	0.15 (0.57)	29.03" Hg (98.31 kPa)

Maximum torque - 1738 lb.-ft. (2357 Nm) at 1401 rpm

Maximum torque rise - 45.9%

Torque rise at 1682 engine rpm - 37%

Power increase at 1900 engine rpm - 12.5%

#### DRAWBAR PERFORMANCE FUEL CONSUMPTION CHARACTERISTICS

Power Hp (kW)	Drawbar pull lbs (kN)	Speed mph (km/h)	Crank- shaft speed rpm	Slip %	Fuel Consumption lb/hp.hr (kg/kW.h)	Hp.hr/gal (kW.h/l)	Temp. °F (°C) cool- ing dry bulb	Barom. inch Hg (kPa)
<b>Maximum Power—5th Gear</b>								
476.39 (355.24)	32763 (145.73)	5.45 (8.77)	2100	2.2	0.437 (0.266)	16.04 (3.16)	209 (98)	52 (11)
<b>75% of Pull at Maximum Power—5th Gear</b>								
368.07 (274.47)	24596 (109.41)	5.61 (9.03)	2142	1.3	0.459 (0.279)	15.28 (3.01)	208 (98)	63 (17)
<b>50% of Pull at Maximum Power—5th Gear</b>								
248.38 (185.22)	16361 (72.78)	5.69 (9.16)	2161	0.7	0.520 (0.316)	13.48 (2.66)	191 (88)	64 (18)
<b>75% of Pull at Reduced Engine Speed—9th Gear</b>								
367.44 (274.00)	24568 (109.28)	5.61 (9.03)	1471	1.3	0.407 (0.247)	17.22 (3.39)	199 (93)	63 (17)
<b>50% of Pull at Reduced Engine Speed—9th Gear</b>								
248.14 (185.04)	16382 (72.87)	5.68 (9.14)	1478	0.7	0.439 (0.267)	15.98 (3.15)	181 (83)	63 (17)

**CONSUMABLE Fluids, OIL and TIME: Fuel** No. 2 Diesel **Specific gravity converted to 60°/60°F (15°/15°C)** 0.8417 **Fuel weight** 7.008 lbs/gal (0.840 kg/l) **Diesel Exhaust Fluid (DEF)** 32% aqueous urea solution **DEF weight** 9.071 lbs/gal (1.087 kg/l) **Oil SAE 15W40 API service classification** CI-4 **Transmission and hydraulic lubricant** Akcela Hy-Tran Ultra transmission fluid **Front and rear axle lubricant** Akcela Nexlore hydraulic fluid **Total time engine was operated** 17.0 hours

**ENGINE: Make** F.P.T. Diesel **Type** six cylinder vertical with two turbochargers, air to air intercooler, water to air intercooler and D.E.F. (diesel exhaust fluid) exhaust treatment **Serial No.** \*A-000-002850\* **Crankshaft** lengthwise **Rated engine speed** 2100 **Bore and stroke** 5.315" x 5.906" (135.0 mm x 150.0 mm) **Compression ratio** 15.5 to 1 **Displacement** 786 cu in (12880 ml) **Starting system** 24 volt **Lubrication** pressure **Air cleaner** two paper elements and aspirator **Oil filter** one full flow cartridge **Oil cooler** engine coolant heat exchanger for crankcase oil, separate radiators for hydraulic and transmission oil **Fuel filter** two paper elements **Fuel cooler** radiator for pump return fuel **Muffler** vertical **Cooling medium temperature control** thermostat and variable speed fan

**ENGINE OPERATING PARAMETERS: Fuel rate:** 535 engine hp: 178.8 - 191.6 lb/h (81.1 - 86.9 kg/h) 600 engine hp: 199.7 - 213.8 lb/h (90.6 - 97.0 kg/h) **High idle:** 2165 - 2215 rpm **Turbo boost:** nominal 36.3 - 39.1 psi (240 - 270 kPa) as measured 37.4 psi (258 kPa)

**CHASSIS: Type** Tracklayer - rubber tracked **Serial No.** \*ZCF130783\* **Track width** rear 88.0" (2235 mm) front 88.0" (2235 mm) **Trackbase** 154.0" (3912 mm) **Length of track on ground** 29.4" (748 mm) **Hydraulic control system** direct engine drive **Transmission** selective gear fixed ratio with full range operator controlled powershift **Nominal travel speeds mph (km/h)** first 2.78 (4.47) second 3.34 (5.38) third 4.04 (6.50) fourth 4.87 (7.83) fifth 5.59 (8.99) sixth 6.14 (9.88) seventh 6.73 (10.83) eighth 7.39 (11.90) ninth 8.13 (13.08) tenth 8.93 (14.37) eleventh 9.79 (15.76) twelfth 10.76 (17.32) thirteenth 12.35 (19.88) fourteenth 14.88 (23.94) fifteenth 17.98 (28.93) sixteenth 21.64 (34.82) reverse 4.21 (6.77), 9.30 (14.97) **Clutch** multiple wet disc electro-hydraulically operated by foot pedal **Brakes** single wet disc hydraulically actuated by foot pedal **Steering** hydrostatic and articulated **Power take-off** 1000 rpm at 1998 engine rpm **Unladen tractor mass** 59090 lb (26803 kg)

**DRAWBAR PERFORMANCE AT 2100 ENGINE RPM  
MAXIMUM POWER IN SELECTED GEARS**

Power Hp (kW)	Drawbar pull lbs (kN)	Speed mph (km/h)	Crank- shaft speed rpm	Slip %	Fuel Consumption lb/hp.hr (kg/kW.h)	Temp. °F(°C) cool- ing med	Air dry bulb	Barom. inch Hg (kPa)	
1st Gear									
366.40 (273.22)	56424 (250.99)	2.44 (3.92)	2136	13.6	0.509 (0.310)	13.76 (2.71)	201 (94)	49 (9)	28.77 (97.43)
2nd Gear									
431.57 (321.82)	53446 (237.74)	3.03 (4.88)	2126	10.4	0.477 (0.290)	14.71 (2.90)	210 (99)	50 (10)	28.77 (97.43)
3rd Gear									
467.37 (348.51)	45924 (204.28)	3.82 (6.14)	2100	5.5	0.447 (0.272)	15.67 (3.09)	209 (98)	50 (10)	28.78 (97.46)
4th Gear									
473.07 (352.77)	37716 (167.77)	4.70 (7.56)	2100	3.1	0.440 (0.268)	15.93 (3.14)	208 (98)	54 (12)	28.79 (97.49)
5th Gear									
476.39 (355.24)	32763 (145.73)	5.45 (8.77)	2100	2.2	0.437 (0.266)	16.04 (3.16)	209 (98)	52 (11)	28.79 (97.49)
6th Gear									
479.58 (357.62)	29911 (133.05)	6.01 (9.67)	2100	1.9	0.435 (0.265)	16.12 (3.17)	208 (98)	57 (14)	28.79 (97.49)
7th Gear									
468.08 (349.04)	26588 (118.27)	6.60 (10.62)	2100	1.6	0.445 (0.271)	15.73 (3.10)	209 (98)	61 (16)	28.78 (97.46)
8th Gear									
470.53 (350.87)	24219 (107.73)	7.29 (11.72)	2101	1.3	0.442 (0.269)	15.85 (3.12)	208 (98)	62 (16)	28.77 (97.43)
9th Gear									
464.96 (346.72)	21741 (96.71)	8.02 (12.91)	2100	1.0	0.447 (0.272)	15.67 (3.09)	207 (97)	63 (17)	28.77 (97.43)

**REPAIRS AND ADJUSTMENTS:** No repairs or adjustments.

**Note:** This tractor has a driveline protection system that limits the maximum engine torque in gears 1 through 4.

**REMARKS:** All test results were determined from observed data obtained in accordance with official OECD, SAE and Nebraska test procedures. For the maximum power tests, the fuel temperature at the injection pump inlet was maintained at 110°F (43°C). The performance figures on this Summary were taken from a test conducted under the OECD Code 2 test procedure.

We, the undersigned, certify that this is a true and correct report of official Tractor Test No. **2049**, Nebraska Summary 849, December 21, 2012.

Roger M. Hoy  
Director

M.R. Riley  
P.J. Jasa  
J.D. Luck  
Board of Tractor Test Engineers

TRACTOR SOUND LEVEL WITH CAB	dB(A)
At no load in 4th gear	74.9
Bystander in 16th Gear	88.8

**TIRES, BALLAST AND WEIGHT**

<b>Rear tracks - no &amp; size</b>	Tested without ballast 2 x 30.0 in (762 mm)
<b>Front tracks - no &amp; size</b>	2 x 30.0 in (762 mm)
<b>Height of drawbar</b>	20.5 in (520 mm)
<b>Static weight with operator- Rear</b>	24910 lb (11299 kg)
- Front	34355 lb (15583 kg)
- Total	59265 lb (26882 kg)

**DRAWBAR PERFORMANCE AT 1900 ENGINE RPM  
MAXIMUM POWER IN SELECTED GEARS**

Power Hp (kW)	Drawbar pull lbs (kN)	Speed mph (km/h)	Crank- shaft speed rpm	Slip %	Fuel Consumption lb/hp.hr (kg/kW.h)	Temp. °F(°C) cool- ing med	Air dry bulb	Barom. inch Hg (kPa)	
1st Gear									
369.82 (275.77)	56328 (250.56)	2.47 (3.97)	2128	12.3	0.502 (0.305)	13.96 (2.75)	199 (93)	48 (9)	28.77 (97.43)
2nd Gear									
432.21 (322.30)	53678 (238.77)	3.02 (4.86)	2117	10.3	0.476 (0.289)	14.73 (2.90)	209 (98)	49 (9)	28.76 (97.39)
3rd Gear									
484.68 (361.42)	52104 (231.77)	3.49 (5.62)	2000	9.1	0.455 (0.277)	15.40 (3.03)	210 (99)	50 (10)	28.77 (97.43)
4th Gear									
519.16 (387.14)	47251 (210.18)	4.12 (6.63)	1900	6.2	0.431 (0.262)	16.25 (3.20)	207 (97)	55 (13)	28.79 (97.49)
5th Gear									
532.17 (396.84)	41156 (183.07)	4.85 (7.81)	1899	4.0	0.420 (0.255)	16.70 (3.29)	207 (97)	53 (12)	28.79 (97.49)
6th Gear									
534.66 (398.70)	37398 (166.35)	5.37 (8.63)	1900	3.1	0.418 (0.254)	16.76 (3.30)	207 (97)	56 (13)	28.79 (97.49)
7th Gear									
531.13 (396.06)	33555 (149.26)	5.94 (9.55)	1901	2.4	0.421 (0.256)	16.65 (3.28)	208 (98)	61 (16)	28.77 (97.43)
8th Gear									
531.12 (396.06)	30472 (135.55)	6.54 (10.53)	1900	1.9	0.423 (0.257)	16.58 (3.27)	210 (99)	61 (16)	28.78 (97.46)
9th Gear									
530.49 (395.59)	27549 (122.54)	7.22 (11.62)	1900	1.6	0.422 (0.256)	16.62 (3.27)	211 (99)	62 (17)	28.77 (97.43)
10th Gear									
527.06 (393.02)	24627 (109.55)	8.03 (12.91)	1916	1.3	0.424 (0.258)	16.54 (3.26)	212 (100)	62 (17)	28.77 (97.43)

## HYDRAULIC PERFORMANCE

CATEGORY: IVN

Quick Attach: yes

OECD Static test

Maximum force exerted through whole range:	19728 lbs (87.8 kN)	
	<b>Three outlet sets combined</b>	
	<u>Standard pump</u>	<u>High flow pump</u>
i) Sustained pressure of the open relief valve:	2877 psi (198 bar)	2915 psi (201 bar)
ii) Pump delivery rate at minimum pressure and rated engine speed:	43.8 GPM (165.8 l/min)	60.9 GPM (230.6 l/min)
iii) Pump delivery rate at maximum hydraulic power:	43.3 GPM (163.7 l/min)	56.7 GPM (214.8 l/min)
Delivery pressure:	2526 psi (174 bar)	2477 psi (171 bar)
Power:	63.7 HP (47.5 kW)	82.0 Hp (61.1 kW)

	<b>Single outlet set</b>	
ii) Pump delivery rate at minimum pressure and rated engine speed:	42.8 GPM (162.2 l/min)	47.4 GPM (179.5 l/min)
iii) Pump delivery rate at maximum hydraulic power:	42.7 GPM (161.6 l/min)	42.7 GPM (161.5 l/min)
Delivery pressure:	2024 psi (139 bar)	2139 psi (148 bar)
Power:	50.4 HP (37.6 kW)	53.3 Hp (39.7 kW)

### TwinFlow system

	<b>Two outlet sets combined</b>	
	<u>Standard pump</u>	<u>TwinFlow pump</u>
i) Sustained pressure at compensator cutoff:	2877 psi (198 bar)	2855 psi (197 bar)
ii) Pump delivery rate at minimum pressure and rated engine speed:	43.8 GPM (165.8 l/min)	57.3 GPM (217.0 l/min)
Combined flow:	101.1 GPM (382.8 l/min)	
iii) Pump delivery rate at maximum hydraulic power:	43.3 GPM (163.7 l/min)	56.4 GPM (213.6 l/min)
Delivery pressure:	2526 psi (174 bar)	2479 psi (171 bar)
Power:	63.7 HP (47.5 kW)	81.6 Hp (60.9 kW)

	<b>Two outlet sets combined</b>	
	<u>High flow pump</u>	<u>TwinFlow pump</u>
i) Sustained pressure at compensator cutoff:	2993 psi (206 bar)	2855 psi (197 bar)
ii) Pump delivery rate at minimum pressure and rated engine speed:	61.0 GPM (230.9 l/min)	57.3 GPM (217.0 l/min)
Combined flow:	118.3 GPM (447.9 l/min)	
iii) Pump delivery rate at maximum hydraulic power:	56.7 GPM (214.7 l/min)	56.4 GPM (213.6 l/min)
Delivery pressure:	2517 psi (174 bar)	2479 psi (171 bar)
Power:	83.3 HP (62.1 kW)	81.6 Hp (60.9 kW)

## HITCH DIMENSIONS AS TESTED - NO LOAD

	inch	mm
A	32.6	827
B	29.9	760
C	23.2	590
D	22.0	558
E	13.5	342
F	13.4	340
G	35.0	890
*G'	11.8	300
H	4.6	117
I	22.8	578
J	21.6	550
K	29.0	736
L	56.3	1431
*L'	63.6	1615
M	34.3	871
N	46.5	1181
O	7.9	200
P	45.4	1154
Q	40.9	1039
R	38.5	978

\*G' to undercarriage pivot point  
\*L' to Quick coupler ends

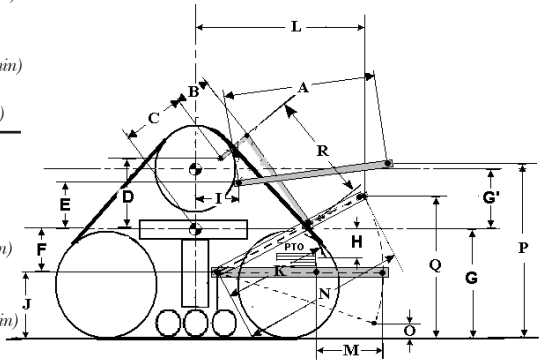

**Case IH Steiger 600 Quadtrac Diesel**