

University of Nebraska - Lincoln

DigitalCommons@University of Nebraska - Lincoln

Nebraska Tractor Tests

Tractor Test and Power Museum, The Lester F.
Larsen

2012

Test 2050A: Case IH Farmall 140A

Nebraska Tractor Test Laboratory

University of Nebraska-Lincoln, tractortestlab@unl.edu

Follow this and additional works at: <https://digitalcommons.unl.edu/tractormuseumlit>



Part of the [Energy Systems Commons](#), [History of Science, Technology, and Medicine Commons](#), [Other Mechanical Engineering Commons](#), [Physical Sciences and Mathematics Commons](#), [Science and Mathematics Education Commons](#), and the [United States History Commons](#)

Laboratory, Nebraska Tractor Test, "Test 2050A: Case IH Farmall 140A" (2012). *Nebraska Tractor Tests*. 2461.

<https://digitalcommons.unl.edu/tractormuseumlit/2461>

This Article is brought to you for free and open access by the Tractor Test and Power Museum, The Lester F. Larsen at DigitalCommons@University of Nebraska - Lincoln. It has been accepted for inclusion in Nebraska Tractor Tests by an authorized administrator of DigitalCommons@University of Nebraska - Lincoln.

NEBRASKA OECD TRACTOR TEST 2050A—SUMMARY 863A

CASE IH FARMALL 140A DIESEL

8 SPEED

POWER TAKE-OFF PERFORMANCE

Power HP (kW)	Crank shaft speed rpm	Gal/hr (l/h)	lb/hp.hr (kg/kW.h)	Hp.hr/gal (kW.h/l)	Mean Atmospheric Conditions
MAXIMUM POWER AND FUEL CONSUMPTION					
Rated Engine Speed—(PTO speed—1074 rpm)					
116.27 (86.70)	2200	8.48 (32.10)	0.511 (0.311)	13.71 (2.70)	
Standard Power Take-off Speed (1000 rpm)					
120.22 (89.65)	2049	8.21 (31.10)	0.479 (0.291)	14.63 (2.88)	
Maximum Power (1 hour)					
126.47 (94.31)	1750	7.64 (28.94)	0.424 (0.258)	16.54 (3.26)	

VARYING POWER AND FUEL CONSUMPTION

116.27 (86.70)	2200	8.48 (32.10)	0.511 (0.311)	13.71 (2.70)	Air temperature
104.00 (77.55)	2314	8.04 (30.45)	0.542 (0.330)	12.93 (2.55)	73°F (23°C)
78.80 (58.76)	2335	6.82 (25.83)	0.607 (0.369)	11.55 (2.27)	Relative humidity
52.60 (39.22)	2341	5.28 (19.99)	0.704 (0.428)	9.96 (1.96)	16%
26.70 (19.91)	2377	3.58 (13.56)	0.940 (0.572)	7.45 (1.47)	Barometer
1.20 (0.89)	2415	2.51 (9.51)	14.667 (8.921)	0.48 (0.09)	28.94 Hg (98.00 kPa)

Maximum torque - 510 lb.-ft. (691 Nm) at 1000 rpm
 Maximum torque rise - 84.0%
 Torque rise at 1760 engine rpm - 36%
 Power increase at 1750 engine rpm - 8.8%

DRAWBAR PERFORMANCE UNBALLASTED - FRONT DRIVE ENGAGED FUEL CONSUMPTION CHARACTERISTICS

Power Hp (kW)	Drawbar pull lbs (kN)	Speed mph (km/h)	Crank- shaft speed rpm	Slip %	Fuel Consumption lb/hp.hr (kg/kW.h)	Hp.hr/gal (kW.h/l)	Temp. °F (°C) cool- ing med	Air dry bulb	Barom. inch Hg (kPa)
Maximum Power—5th (H1) Gear									
103.64 (77.28)	6321 (28.11)	6.15 (9.90)	2200	7.5	0.580 (0.353)	12.08 (2.38)	185 (85)	47 (8)	28.74 (97.33)
75% of Pull at Maximum Power—5th (H1) Gear									
83.78 (62.47)	4721 (21.00)	6.66 (10.71)	2326	5.4	0.634 (0.386)	11.05 (2.18)	186 (86)	59 (15)	28.66 (97.05)
50% of Pull at Maximum Power—5th (H1) Gear									
56.38 (42.04)	3114 (13.85)	6.79 (10.93)	2338	3.8	0.730 (0.444)	9.60 (1.89)	185 (85)	59 (15)	28.66 (97.05)
75% of Pull at Reduced Engine Speed—6th (H2) Gear									
83.54 (62.29)	4788 (21.30)	6.55 (10.53)	1484	5.4	0.449 (0.273)	15.62 (3.08)	180 (82)	58 (14)	28.65 (97.02)
50% of Pull at Reduced Engine Speed—6th (H2) Gear									
56.66 (42.25)	3100 (13.79)	6.86 (11.03)	1526	3.6	0.487 (0.296)	14.38 (2.83)	182 (83)	59 (15)	28.66 (97.05)

Location of tests: Nebraska Tractor Test Laboratory, University of Nebraska, Lincoln Nebraska 68583-0832

Dates of tests: November 27 - December 6, 2012

Manufacturer: CNH De Mexico, Queretaro Mexico

FUEL, OIL and TIME: Fuel No. 2 Diesel Specific gravity converted to 60°/60° F (15°/15°C) 0.8417 Fuel weight 7.008 lbs/gal (0.840 kg/l) Oil SAE 15W40 API service classification CI-4 Transmission and hydraulic lubricant Case IH Akcela Nexlore fluid Front axle lubricant Case IH Akcela Nexlore fluid Total time engine was operated 17.5 hours

ENGINE: Make F.P.T NEF series Diesel Type six cylinder vertical with turbocharger and air to air intercooler Serial No. 908209 Crankshaft lengthwise Rated engine speed 2200 Bore and stroke 4.094" x 5.197" (104.0 mm x 132.0 mm) Compression ratio 17.5 to 1 Displacement 410 cu in (6728 ml) Starting system 12 volt Lubrication pressure Air cleaner two paper elements Oil filter one full flow cartridge Oil cooler engine coolant heat exchanger for crankcase oil, radiator for hydraulic and transmission oil Fuel filter one paper element Muffler vertical Cooling medium temperature control one thermostat

ENGINE OPERATING PARAMETERS: Fuel rate: 56.2 - 59.9 lb/h (25.5 - 27.2 kg/h) High idle: 2350 - 2450 rpm Turbo boost: nominal 16.0 - 18.9 psi (110 - 130 kPa) as measured 17.4 psi (120 kPa)

CHASSIS: Type front wheel assist Serial No. NH000473M Tread width rear 62.0" (1575 mm) to 92.0" (2337 mm) front 64.0" (1626 mm) to 80.0" (2032 mm) Wheelbase 104.0" (2642 mm) Hydraulic control system direct engine drive Transmission selective gear fixed ratio Nominal travel speeds mph (km/h) first 1.78 (2.85) second 2.73 (4.39) third 3.71 (5.96) fourth 5.14 (8.27) fifth 6.54 (10.52) sixth 10.06 (16.20) seventh 13.66 (22.00) eighth 18.98 (30.54) reverse 1.83 (2.95), 2.82 (4.54), 3.83 (6.17), 5.32 (8.56), 6.76 (10.88), 10.40 (16.75), 14.13 (22.74), 19.62 (31.59) Clutch single dry disc operated by foot pedal Brakes single wet disc operated by two foot pedals which can be locked together Steering hydrostatic Power take-off 540 rpm at 1890 engine rpm or 1000 rpm at 2049 engine rpm Unladen tractor mass 11000 lb (4989 kg)

DRAWBAR PERFORMANCE
UNBALLASTED - FRONT DRIVE ENGAGED
MAXIMUM POWER IN SELECTED GEARS

Power Hp (kW)	Drawbar pull lbs (kN)	Speed mph (km/h)	Crank- shaft speed rpm	Slip %	Fuel Consumption lb/hp.hr (kg/kW.h)	Consumption Hp.hr/gal (kW.h/l)	Temp. °F (°C) cool- ing med	Air dry bulb	Barom. inch Hg (kPa)
3rd(L3)Gear									
81.27 (60.60)	9034 (40.18)	3.38 (5.43)	2312	14.9	0.688 (0.419)	10.18 (2.01)	185 (85)	51 (10)	28.71 (97.22)
4th(L4)Gear									
99.47 (74.17)	8048 (35.80)	4.64 (7.46)	2200	11.4	0.605 (0.368)	11.58 (2.28)	184 (84)	47 (8)	28.74 (97.33)
5th(H1) Gear									
103.64 (77.28)	6321 (28.11)	6.15 (9.90)	2200	7.5	0.580 (0.353)	12.08 (2.38)	185 (85)	47 (8)	28.74 (97.33)
6th(H2) Gear									
101.91 (75.99)	3921 (17.44)	9.75 (15.68)	2197	4.7	0.586 (0.356)	11.96 (2.36)	185 (85)	54 (12)	28.70 (97.19)

UNBALLASTED - FRONT DRIVE ENGAGED-1750 RPM

Power Hp (kW)	Drawbar pull lbs (kN)	Speed mph (km/h)	Crank- shaft speed rpm	Slip %	Fuel Consumption lb/hp.hr (kg/kW.h)	Consumption Hp.hr/gal (kW.h/l)	Temp. °F (°C) cool- ing med	Air dry bulb	Barom. inch Hg (kPa)
3rd(L3)Gear									
81.40 (60.70)	9038 (40.20)	3.38 (5.43)	2312	14.8	0.685 (0.417)	10.23 (2.02)	185 (85)	51 (11)	28.71 (97.22)
4th(L4)Gear									
100.13 (74.66)	8099 (36.02)	4.64 (7.47)	2198	11.4	0.603 (0.367)	11.62 (2.29)	184 (84)	47 (8)	28.73 (97.29)
5th(H1)Gear									
107.61 (80.24)	8072 (35.91)	5.00 (8.05)	1863	11.2	0.519 (0.316)	13.51 (2.66)	182 (83)	48 (9)	28.73 (97.29)
6th(H2)Gear									
111.17 (82.90)	5469 (24.33)	7.63 (12.27)	1751	6.4	0.483 (0.294)	14.51 (2.86)	183 (84)	55 (13)	28.69 (97.16)

TRACTOR SOUND LEVEL WITH CAB	Front Wheel Drive	
	Engaged dB(A)	Disengaged dB(A)
At no load in 4th (4L) gear	81.7	81.7
Bystander in 8th (4H) gear		87.0

TIRES AND WEIGHT

Rear Tires - No., size, ply & psi(kPa)
Front Tires - No., size, ply & psi(kPa)
Height of Drawbar
Static Weight with operator - Rear
 - Front
 - Total

Tested Without Ballast

Two 18.4-38;8;16(110)
 Two 14.9-28;8;16(110)
 25.0 in (635 mm)
 6650 lb (3016 kg)
 4525 lb (2053 kg)
 11175 lb (5069 kg)

NOTE: The performance results on this report were obtained from tests carried out on the New Holland TS6.140 Diesel.

REPAIRS AND ADJUSTMENTS: No repairs or adjustments.

REMARKS: All test results were determined from observed data obtained in accordance with official OECD, SAE and Nebraska test procedures. This tractor did not meet the manufacturer's implement flow claim of 22 GPM (83 L/min). For the maximum power tests the fuel temperature at the fuel pump return was maintained at 165°F (74°C). The performance figures on this summary were taken from a test conducted under the OECD Code II test code procedure.

We, the undersigned, certify that this is a true and correct report of official Tractor Test No. **2050A**, Nebraska Summary 863A, December 21, 2012.

Roger M. Hoy
 Director

M.R. Riley
 P.J. Jasa
 J.D. Luck
 Board of Tractor Test Engineers

HYDRAULIC PERFORMANCE

CATEGORY: II

Quick Attach: None

OECD Static test

Maximum force exerted through whole range: 6174 lbs (27.46 kN) (2 external lift cylinders)

Two pump system

two outlet sets combined

- i) Sustained pressure of the open relief valve: 2413 psi (166 bar)
- ii) Pump delivery rate at minimum pressure and rated engine speed: 20.2 GPM (76.5 l/min)
- iii) Pump delivery rate at maximum hydraulic power: 17.4 GPM (65.9 l/min)
- Delivery pressure: 1725 psi (119 bar)
- Power: 17.5 HP (13.1 kW)

single outlet set

- i) Sustained pressure of the open relief valve: 2431 psi (168 bar)
- ii) Pump delivery rate at minimum pressure and rated engine speed: 16.4 GPM (61.9 l/min)
- iii) Pump delivery rate at maximum hydraulic power: 15.5 GPM (58.7 l/min)
- Delivery pressure: 1773 psi (122 bar)
- Power: 16.0 HP (12.0 kW)

THREE POINT HITCH PERFORMANCE (SAE Static test)

Observed maximum pressure psi. (bar)	2480 (171)
Location:	lift cylinder
Hydraulic oil temperature: °F (°C)	145 (63)
Location:	pump inlet
Category:	II
Quick attach:	none

Two external lift cylinders

System pressure 2210 psi (152 Bar)

Hitch point distance to ground level in. (mm)	8.0 (203)	15.0 (381)	22.0 (559)	29.0 (737)	36.0 (914)
Lift force on frame lb	9270	8622	8199	8361	7326
" " " " " " (kN)	(41.2)	(38.4)	(36.5)	(37.2)	(32.6)

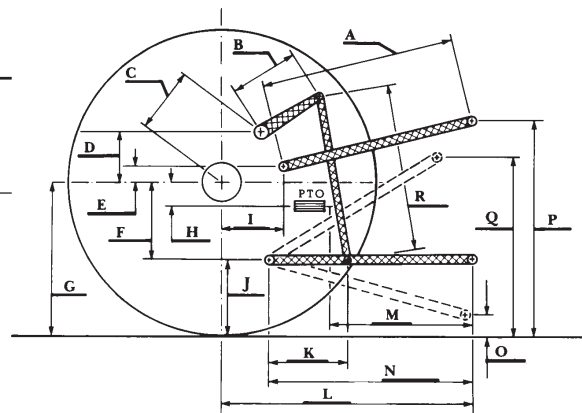

HITCH DIMENSIONS AS TESTED—NO LOAD

	SAE Test		OECD Test	
	inch	mm	inch	mm
A	27.7	705	28.5	724
B	9.8	250	9.8	250
C	14.1	357	14.1	357
D	13.5	342	13.5	342
E	8.1	205	8.1	205
F	9.0	229	9.0	229
G	30.3	770	30.3	770
H	0.4	10	0.4	10
I	12.7	323	12.7	323
J	21.3	541	21.3	541
K	18.1	460	18.1	460
L	40.8	1037	40.8	1037
M	22.9	581	22.9	581
N	36.6	930	36.6	930
O	8.0	203	8.0	203
P	40.3	1024	45.3	1151
Q	34.0	864	34.0	864
R	32.5	826	32.5	826



CASE IH FARMALL 140A DIESEL

Institute of Agriculture and Natural Resources
University of Nebraska-Lincoln