

University of Nebraska - Lincoln

DigitalCommons@University of Nebraska - Lincoln

---

Nebraska Tractor Tests

Tractor Test and Power Museum, The Lester F. Larsen

---

2013

## Test 2066: Versatile 375

Nebraska Tractor Test Laboratory

University of Nebraska-Lincoln, tractortestlab@unl.edu

Follow this and additional works at: <https://digitalcommons.unl.edu/tractormuseumlit>



Part of the [Energy Systems Commons](#), [History of Science, Technology, and Medicine Commons](#), [Other Mechanical Engineering Commons](#), [Physical Sciences and Mathematics Commons](#), [Science and Mathematics Education Commons](#), and the [United States History Commons](#)

---

Laboratory, Nebraska Tractor Test, "Test 2066: Versatile 375" (2013). *Nebraska Tractor Tests*. 2490.  
<https://digitalcommons.unl.edu/tractormuseumlit/2490>

This Article is brought to you for free and open access by the Tractor Test and Power Museum, The Lester F. Larsen at DigitalCommons@University of Nebraska - Lincoln. It has been accepted for inclusion in Nebraska Tractor Tests by an authorized administrator of DigitalCommons@University of Nebraska - Lincoln.

# NEBRASKA OECD TRACTOR TEST 2066—SUMMARY 884

## VERSATILE 375 DIESEL

### 16 SPEED

#### POWER TAKE-OFF PERFORMANCE

Power HP (kW)	Crank shaft speed rpm	Gal/hr (l/h)	lb/hp.hr (kg/kW.h)	Hp.hr/gal (kW.h/l)	Mean Atmospheric Conditions
<b>MAXIMUM POWER AND FUEL CONSUMPTION</b>					
<b>Rated Engine Speed—(PTO speed—997 rpm)</b>					
302.91 (225.88)	2100	19.91 (75.38)	0.462 (0.281)	15.21 (3.00)	Fuel used during active exhaust regeneration - 0.16 gal (0.60 l) (see Note 1 p.2)
<b>Standard Power Take-off Speed—(PTO speed—997 rpm)</b>					
302.91 (225.88)	2100	19.91 (75.38)	0.462 (0.281)	15.21 (3.00)	
<b>Maximum Power (1 hour)</b>					
358.97 (267.68)	1681	19.81 (74.98)	0.388 (0.236)	18.12 (3.57)	

#### VARYING POWER AND FUEL CONSUMPTION

302.91 (225.88)	2100	19.91 (75.38)	0.462 (0.281)	15.21 (3.00)	Air temperature
263.41 (196.42)	2147	17.85 (67.58)	0.476 (0.290)	14.75 (2.91)	76°F (25°C)
200.19 (149.28)	2176	15.11 (57.21)	0.531 (0.323)	13.25 (2.61)	Relative humidity
134.69 (100.44)	2196	12.74 (48.21)	0.665 (0.404)	10.57 (2.08)	60%
67.50 (50.33)	2200	9.76 (36.95)	1.017 (0.618)	6.91 (1.36)	Barometer
4.79 (3.57)	2199	6.56 (24.84)	9.628 (5.856)	0.73 (0.14)	28.83" Hg (97.63 kPa)

Maximum Torque - 1278 lb.-ft. (1733 Nm) at 1300 rpm  
 Maximum Torque Rise - 68.8%  
 Torque rise at 1681 engine rpm - 48%  
 Power increase at 1680 engine rpm - 18.5%

#### DRAWBAR PERFORMANCE (Unballasted) FUEL CONSUMPTION CHARACTERISTICS

Power Hp (kW)	Drawbar pull lbs (kN)	Speed mph (km/h)	Crank- shaft speed rpm	Slip %	Fuel Consumption lb/hp.hr (kg/kW.h)	Hp.hr/gal (kW.h/l)	Temp. °F (°C) cool- ing med	Air dry bulb	Barom. inch Hg (kPa)
<b>Maximum Power—6th Gear</b>									
291.10 (217.07)	19544 (86.94)	5.59 (8.99)	2099	2.6	0.484 (0.295)	14.51 (2.86)	190 (88)	77 (25)	28.56 (96.72)
<b>75% of Pull at Maximum Power—6th Gear</b>									
226.76 (169.09)	14697 (65.37)	5.79 (9.31)	2161	2.0	0.515 (0.313)	13.64 (2.69)	189 (87)	88 (31)	28.56 (96.72)
<b>50% of Pull at Maximum Power—6th Gear</b>									
153.37 (114.36)	9747 (43.35)	5.90 (9.50)	2190	1.4	0.625 (0.380)	11.24 (2.21)	189 (87)	90 (32)	28.56 (96.72)
<b>75% of Pull at Reduced Engine Speed—9th Gear</b>									
226.37 (168.80)	14633 (65.09)	5.80 (9.33)	1518	2.0	0.450 (0.274)	15.61 (3.07)	190 (88)	88 (31)	28.56 (96.72)
<b>50% of Pull at Reduced Engine Speed—9th Gear</b>									
153.48 (114.45)	9781 (43.51)	5.88 (9.46)	1530	1.4	0.505 (0.307)	13.92 (2.74)	187 (86)	91 (33)	28.57 (96.75)

**Location of Tests:** Nebraska Tractor Test Laboratory, University of Nebraska, Lincoln, Nebraska 68583-0832

**Dates of Test:** September 5-11, 2013

**Manufacturer:** Buhler Versatile, 1260 Clarence Ave Winnipeg, Manitoba, Canada R3T 1T2

**FUEL, OIL and TIME:** Fuel No. 2 Diesel Specific gravity converted to 60°/60°F (15°/15°C) 0.8442 Fuel weight 7.029 lbs/gal (0.842 kg/l) Oil SAE 15W-40 API service classification CJ-4 Transmission, hydraulic and final drive lubricant Hydraul 56 fluid Total time engine was operated: 14.0 hours

**ENGINE:** Make Cummins Diesel Type six cylinder vertical with turbocharger and air to air intercooler Serial No. \*75018140\* Crankshaft lengthwise Rated engine speed 2100 Bore and stroke 5.118" x 5.906" (130.0 mm x 150.0 mm) Compression ratio 16.6 to 1 Displacement 729 cu in (11946 ml) Starting system 12 volt Lubrication pressure Air cleaner two paper elements and aspirator Oil filter one full flow cartridge Oil cooler engine coolant heat exchanger for crankcase oil, radiator for hydraulic oil, radiator for transmission, front and rear axle oil Fuel filter two paper cartridges Fuel cooler radiator for returned fuel Exhaust regenerative particulate filter integrated within a vertical muffler Cooling medium temperature control thermostat

**ENGINE OPERATING PARAMETERS:** Fuel rate: 132.8 - 146.0 lb/h (60.2 - 66.2 kg/h) High idle: 2150 - 2250 rpm Turbo boost: nominal 27.6 - 33.4 psi (190 - 230 kPa) as measured 32.0 psi (220 kPa)

**CHASSIS:** Type four wheel drive with duals Serial No. \*307322\* Tread width rear 72.0" (1828 mm) and 124.9" (3171 mm), front 72.0" (1828 mm) and 124.9" (3171 mm) Wheelbase 135.0" (3430 mm) Hydraulic control system direct engine drive Transmission selective gear fixed ratio with full range operator controlled power shift Nominal travel speeds mph (km/h) first 2.06 (3.32) second 2.62 (4.21) third 3.31 (5.33) fourth 4.21 (6.77) fifth 5.01 (8.06) sixth 5.64 (9.07) seventh 6.36 (10.23) eighth 7.16 (11.52) ninth 8.05 (12.95) tenth 9.06 (14.58) eleventh 10.22 (16.45) twelfth 11.51 (18.52) thirteenth 13.70 (22.05) fourteenth 17.40 (28.00) fifteenth 20.44 (32.90) sixteenth 22.97 (36.96) electronically limited reverse 1.65 (2.65), 4.01 (6.45), 4.51 (7.26), 10.96 (17.64)

## DRAWBAR PERFORMANCE

(Unballasted at 2100 rpm)

### MAXIMUM POWER IN SELECTED GEARS

Power Hp (kW)	Drawbar pull lbs (kN)	Speed mph (km/h)	Crank- shaft speed rpm	Slip %	Fuel Consumption lb/hp.hr (kg/kW.h)	Hp.hr/gal (kW.h/l)	Temp. °F (°C) cool- ing med	Air dry bulb	Barom. inch Hg (kPa)
2nd Gear									
240.10 (179.04)	37957 (168.84)	2.38 (3.82)	2137	12.7	0.556 (0.338)	12.63 (2.49)	190 (88)	77 (25)	28.64 (96.99)
3rd Gear									
278.31 (207.53)	32832 (146.04)	3.18 (5.12)	2100	5.8	0.505 (0.307)	13.91 (2.74)	190 (88)	77 (25)	28.65 (97.02)
4th Gear									
281.33 (209.78)	25622 (113.97)	4.12 (6.63)	2100	3.9	0.499 (0.303)	14.09 (2.78)	190 (88)	78 (26)	28.68 (97.12)
5th Gear									
288.82 (215.37)	21906 (97.44)	4.94 (7.95)	2100	3.0	0.485 (0.295)	14.50 (2.86)	189 (87)	79 (26)	28.57 (96.75)
6th Gear									
291.10 (217.07)	19544 (86.94)	5.59 (8.99)	2099	2.6	0.484 (0.295)	14.51 (2.86)	190 (88)	77 (25)	28.56 (96.72)
7th Gear									
289.76 (216.07)	17202 (76.52)	6.32 (10.17)	2100	2.4	0.486 (0.296)	14.46 (2.85)	189 (87)	74 (23)	28.82 (97.60)
8th Gear									
291.84 (217.63)	15348 (68.27)	7.13 (11.47)	2100	2.1	0.484 (0.294)	14.53 (2.86)	190 (88)	84 (29)	28.57 (96.75)
9th Gear									
286.17 (213.40)	13359 (59.42)	8.03 (12.92)	2100	1.9	0.492 (0.299)	14.30 (2.82)	189 (87)	75 (24)	28.83 (97.63)

**Clutch** wet multiple disc hydraulically actuated by foot pedal **Brakes** single dry caliper per axle hydraulically actuated foot pedal **Steering** hydrostatic and articulated **Power take-off** 1000 rpm at 2105 engine rpm **Unladen tractor mass** 37325 lb (16930 kg)

**REPAIRS AND ADJUSTMENTS:** No repairs or adjustments.

**NOTE 1:** The performance figures on this report are the result of replacing the electronic engine control module of the Versatile 400 with the Versatile 375 module.

**NOTE 2.** The manufacturer declares that the average time between active regenerations is 36 hours, while operated in Auto Filter Cleaning Mode, at rated speed, full PTO load, under steady state conditions.

**REMARKS:** All test results were determined from observed data obtained in accordance with official OECD, SAE and Nebraska test procedures. This tractor did not meet the manufacturer's remote hydraulic flow claim of 58 GPM (220 l/m) with the standard pump. The manufacturer's remote hydraulic flow claim of 113 GPM (428 l/m), with high flow system, was not verified. For the maximum power tests the fuel temperature at the primary fuel filter was maintained at 130°F (55°C). The performance figures on this summary were taken from a test conducted under the OECD Code 2 test procedure.

We, the undersigned, certify that this is a true and correct report of official Tractor Test No. **2066**, Nebraska Summary 884, November 25, 2013.

Roger M. Hoy  
Director

M.F. Kocher  
P.J. Jasa  
J.D. Luck  
Board of Tractor Test Engineers

### TRACTOR SOUND LEVEL WITH CAB

dB(A)

At no load in 5th gear	72.4
Bystander in 14th gear	88.0

### TIRES AND WEIGHT

**Rear Tires** - No., size, ply & psi (kPa)

**Front Tires** - No., size, ply & psi (kPa)

**Height of Drawbar**

**Static Weight with operator** - Rear

- Front

- Total

### Tested Without Ballast

Four 480/80R46;\*\*\*;12(85)

Four 480/80R46;\*\*\*;20(135)

23.0 in (585 mm)

14600 lb (6623 kg)

22900 lb (10387 kg)

37500 lb (17010 kg)

**DRAWBAR PERFORMANCE**  
**(Unballasted at 1680 RPM)**  
**MAXIMUM POWER IN SELECTED GEARS**

Power Hp (kW)	Drawbar pull lbs (kN)	Speed mph (km/h)	Crank- shaft speed rpm	Slip %	Fuel Consumption lb/hp.hr (kg/kW.h)	Fuel Consumption Hp.hr/gal (kW.h/l)	Temp. °F(°C) cool- ing med	Air dry bulb	Barom. inch Hg (kPa)
2nd Gear									
245.35 (182.95)	38115 (169.54)	2.41 (3.88)	2137	11.2	0.546 (0.332)	12.88 (2.54)	190 (88)	76 (25)	28.64 (96.99)
3rd Gear									
285.51 (212.90)	35003 (155.70)	3.06 (4.92)	2051	7.2	0.500 (0.304)	14.06 (2.77)	190 (88)	77 (25)	28.66 (97.05)
4th Gear									
312.68 (233.16)	31452 (139.90)	3.73 (6.00)	1937	5.6	0.467 (0.284)	15.06 (2.97)	190 (88)	80 (27)	28.67 (97.09)
5th Gear									
328.77 (245.16)	29869 (132.86)	4.13 (6.65)	1791	5.1	0.437 (0.266)	16.10 (3.17)	190 (88)	81 (27)	28.68 (97.12)
6th Gear									
335.33 (250.05)	28604 (127.23)	4.40 (7.08)	1680	4.3	0.419 (0.255)	16.78 (3.31)	190 (88)	78 (26)	28.56 (96.72)
7th Gear									
336.90 (251.22)	25310 (112.58)	4.99 (8.03)	1679	3.6	0.417 (0.254)	16.84 (3.32)	190 (88)	75 (24)	28.83 (97.63)
8th Gear									
336.83 (251.17)	22368 (99.50)	5.65 (9.09)	1680	3.1	0.417 (0.254)	16.85 (3.32)	190 (88)	83 (29)	28.56 (96.72)
9th Gear									
338.77 (252.62)	19943 (88.71)	6.37 (10.25)	1679	2.7	0.416 (0.253)	16.91 (3.33)	190 (88)	75 (24)	28.84 (97.66)
10th Gear									
340.07 (253.59)	17728 (78.86)	7.19 (11.57)	1680	2.5	0.413 (0.251)	17.01 (3.35)	189 (87)	75 (24)	28.84 (97.66)
11th Gear									
335.13 (249.91)	15432 (68.64)	8.14 (13.10)	1681	2.2	0.417 (0.254)	16.85 (3.32)	190 (88)	76 (24)	28.84 (97.66)

## HYDRAULIC PERFORMANCE

CATEGORY: IVN

Quick Attach: Yes

OECD Static test

Maximum force exerted through whole range:	13152 lbs(58.5kN)
	<b>Standard pump</b>
	<u>three outlet sets combined</u>
i) Sustained pressure at compensator cutoff:	2890 psi (199 bar)
ii) Pump delivery rate at minimum pressure and rated engine speed:	53.1 GPM(201.0l/min)
iii) Pump delivery rate at maximum hydraulic power:	52.2 GPM(197.5l/min)
Delivery pressure:	2611 psi (180 bar)
Power:	79.5 HP (59.2kW)
	<u>single outlet set</u>
i) Sustained pressure at compensator cutoff:	2883 psi (199 bar)
ii) Pump delivery rate at minimum pressure and rated engine speed:	35.0 GPM(132.5l/min)
iii) Pump delivery rate at maximum hydraulic power:	33.7 GPM(127.7 l/min)
Delivery pressure:	2264 psi (156 bar)
Power:	44.5 HP (33.2kW)

## HITCH DIMENSIONS AS TESTED—NO LOAD

	inch	mm
A	27.2	690
B	19.3	490
C	20.1	510
D	18.6	472
E	11.9	302
F	10.7	273
G	36.2	920
H	0.5	13
I	25.7	652
J	25.5	647
K	25.0	635
L	53.7	1364
*L'	60.4	1534
M	23.6	599
N	43.0	1093
O	9.1	230
P	53.0	1347
Q	43.5	1105
R	34.3	870

\*L' to Quick Attach ends

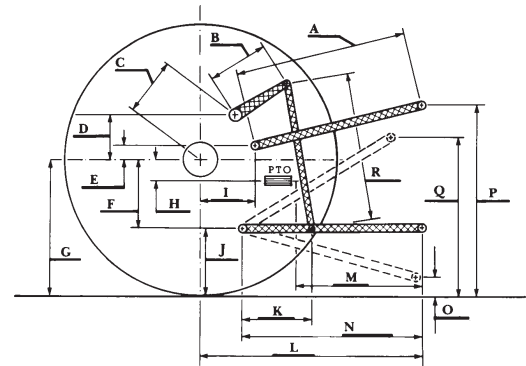

**VERSATILE 375 DIESEL**