

University of Nebraska - Lincoln

DigitalCommons@University of Nebraska - Lincoln

Nebraska Tractor Tests

Tractor Test and Power Museum, The Lester F.
Larsen

2013

Test 2076: John Deere 6105M

Nebraska Tractor Test Laboratory

University of Nebraska-Lincoln, tractortestlab@unl.edu

Follow this and additional works at: <https://digitalcommons.unl.edu/tractormuseumlit>



Part of the [Energy Systems Commons](#), [History of Science, Technology, and Medicine Commons](#), [Other Mechanical Engineering Commons](#), [Physical Sciences and Mathematics Commons](#), [Science and Mathematics Education Commons](#), and the [United States History Commons](#)

Laboratory, Nebraska Tractor Test, "Test 2076: John Deere 6105M" (2013). *Nebraska Tractor Tests*. 2480. <https://digitalcommons.unl.edu/tractormuseumlit/2480>

This Article is brought to you for free and open access by the Tractor Test and Power Museum, The Lester F. Larsen at DigitalCommons@University of Nebraska - Lincoln. It has been accepted for inclusion in Nebraska Tractor Tests by an authorized administrator of DigitalCommons@University of Nebraska - Lincoln.

NEBRASKA OECD TRACTOR TEST 2076—SUMMARY 892

JOHN DEERE 6105M POWRQUAD-PLUS DIESEL

24 SPEED

POWER TAKE-OFF PERFORMANCE

Power HP (kW)	Crank shaft rpm	Gal/hr (l/h)	lb/hp.hr (kg/kW.h)	Hp.hr/gal (kW.h/l)	Mean Atmospheric Conditions
MAXIMUM POWER AND FUEL CONSUMPTION					
Rated Engine Speed—(PTO speed—1071 rpm)					
87.83 (65.49)	2101	5.65 (21.37)	0.452 (0.275)	15.56 (3.06)	Fuel used during active exhaust regeneration - 0.59 gal (2.22 l) (see Note 1 p.2)
Standard Power Take-off Speed (1000 rpm)					
96.86 (72.23)	1962	5.79 (21.93)	0.420 (0.256)	16.72 (3.29)	
Maximum Power (1 hour)					
99.07 (73.87)	1852	5.81 (21.99)	0.412 (0.251)	17.05 (3.36)	

VARYING POWER AND FUEL CONSUMPTION

87.83 (65.49)	2101	5.65 (21.37)	0.452 (0.275)	15.56 (3.06)	Air temperature
77.10 (57.49)	2169	5.18 (19.61)	0.472 (0.287)	14.88 (2.93)	73°F (23°C)
58.81 (43.86)	2197	4.39 (16.61)	0.525 (0.319)	13.40 (2.64)	Relative humidity
39.52 (29.47)	2223	3.57 (13.51)	0.635 (0.386)	11.08 (2.18)	28%
19.99 (14.91)	2240	2.75 (10.41)	0.967 (0.588)	7.27 (1.43)	Barometer
1.53 (1.14)	2250	2.07 (7.82)	9.468 (5.759)	0.74 (0.15)	28.79" Hg (97.49 kPa)

Maximum Torque - 333 lb.-ft. (452 Nm) at 1401 rpm
 Maximum Torque rise - 51.7%
 Torque rise at 1681 engine rpm - 38%
 Power increase at 1801 rpm - 10.3%

DRAWBAR PERFORMANCE (Unballasted—Front Drive Engaged) FUEL CONSUMPTION CHARACTERISTICS

Power Hp (kW)	Drawbar pull lbs (kN)	Speed mph (km/h)	Crank- shaft speed rpm	Slip %	Fuel Consumption lb/hp.hr (kg/kW.h)	Hp.hr/gal (kW.h/l)	Temp. °F (°C) cool- ing med	Air dry bulb	Barom. inch Hg (kPa)
Maximum Power—11th (C3) Gear									
82.13 (61.24)	5844 (25.99)	5.27 (8.48)	2100	3.5	0.487 (0.296)	14.45 (2.85)	188 (87)	55 (13)	28.64 (96.99)
75% of Pull at Maximum Power—11th (C3) Gear									
64.75 (48.28)	4369 (19.43)	5.56 (8.95)	2194	2.7	0.541 (0.329)	13.00 (2.56)	188 (86)	58 (15)	28.52 (96.58)
50% of Pull at Maximum Power—11th (C3) Gear									
44.00 (32.81)	2920 (12.99)	5.65 (9.09)	2213	1.9	0.642 (0.391)	10.95 (2.16)	187 (86)	59 (15)	28.50 (96.51)
75% of Pull at Reduced Engine Speed—14th (D2) Gear									
64.80 (48.32)	4373 (19.45)	5.56 (8.95)	1601	2.6	0.481 (0.293)	14.61 (2.88)	188 (87)	60 (15)	28.47 (96.41)
50% of Pull at Reduced Engine Speed—14th (D2) Gear									
44.12 (32.90)	2937 (13.06)	5.64 (9.07)	1611	1.8	0.539 (0.328)	13.05 (2.57)	187 (86)	60 (15)	28.49 (96.47)

Location of tests: Nebraska Tractor Test Laboratory, University of Nebraska, Lincoln, Nebraska 68583-0832

Dates of tests: October 23 to November 18, 2013

Manufacturer: John Deere Werke Mannheim, John-Deere-Straße 90, Mannheim Germany

FUEL, OIL and Time: Fuel No. 2 Diesel Specific gravity converted to 60°/60°F (15°/15°C) 0.8442 Fuel weight 7.029 lbs/gal (0.842 kg/l) Oil SAE 10W-30 API service classification CJ-4 Transmission and hydraulic lubricant John Deere Hy-Gard II fluid Front axle lubricant John Deere Hy-Gard II fluid Total time engine was operated 20.0 hours.

ENGINE: Make John Deere Diesel **Type** four cylinder vertical with turbocharger and air to air intercooler **Serial No.** *CD4045R024531* **Crankshaft** lengthwise **Rated engine speed** 2100 **Bore and stroke** 4.19" x 5.00" (106.5 mm x 127.0 mm) **Compression ratio** 17.2 to 1 **Displacement** 276 cu in (4525 ml) **Starting system** 12 volt **Lubrication** pressure **Air cleaner** two paper elements **Oil filter** one full flow cartridge **Oil cooler** engine coolant heat exchanger for crankcase oil, engine coolant heat exchanger for hydraulic and transmission oil **Fuel filter** one paper element and one paper cartridge with water separator **Fuel cooler** radiator for pump return fuel **Exhaust** regenerative particulate filter integrated within an underhood muffler with vertical outlet **Cooling medium temperature control** two thermostats and variable speed fan

ENGINE OPERATING PARAMETERS: Fuel rate: 37.9 - 41.1 lb/h (17.2 - 18.6 kg/h) **High idle:** 2225 - 2275 rpm **Turbo boost:** nominal 15.2-18.1 psi (105-125 kPa) as measured 16.3 psi (113 kPa)

CHASSIS: Type front wheel assist **Serial No.** *1L06105MTDG764149* **Tread width** rear 63.5" (1612 mm) to 75.4" (1916 mm) front 62.4" (1584 mm) to 79.4" (2016 mm) **Wheel base** 101.6" (2580 mm) **Hydraulic control system** direct engine drive **Transmission** selective gear fixed ratio with partial (4) range operator controlled powershift **Nominal travel speeds mph (km/h)** first 0.93 (1.50) second 1.12 (1.81) third 1.35 (2.17) fourth 1.65 (2.65) fifth 2.28 (3.67) sixth 2.74 (4.42) seventh 3.29 (5.29) eighth 3.72 (5.98) ninth 4.03 (6.48) tenth 4.47 (7.20) eleventh 5.36 (8.62) twelfth 6.09 (9.81) thirteenth 6.56 (10.56) fourteenth 7.34 (11.81) fifteenth 8.79 (14.15) sixteenth 9.90 (15.94) seventeenth 10.77 (17.33) eighteenth 11.93 (19.20) nineteenth 13.37 (21.52) twentieth 14.29 (22.99) twenty-first 16.11 (25.92) twenty-second 17.50 (28.16) twenty-third 19.29 (31.04) twenty-fourth 23.63 (38.02)

DRAWBAR PERFORMANCE
Unballasted-Front Drive Engaged-2100 Engine RPM
MAXIMUM POWER IN SELECTED GEARS

Power Hp (kW)	Drawbar pull lbs (kN)	Speed mph (km/h)	Crankshaft speed rpm	Slip %	Fuel Consumption lb/hp.hr (kg/kW.h)	Consumption Hp.hr/gal (kW.h/l)	Temp. °F(°C) cooling med	Air dry bulb	Barom. inch Hg (kPa)
6th (B2) Gear									
70.08 (52.26)	10723 (47.70)	2.46 (3.95)	2143	14.3	0.575 (0.350)	12.23 (2.41)	190 (88)	47 (8)	28.70 (97.19)
7th (B3) Gear									
79.26 (59.10)	9587 (42.64)	3.10 (4.99)	2100	7.7	0.504 (0.307)	13.93 (2.74)	189 (87)	48 (9)	28.70 (97.19)
8th (C1) Gear									
79.22 (59.07)	8318 (37.00)	3.57 (5.75)	2100	5.8	0.506 (0.308)	13.90 (2.74)	188 (87)	54 (12)	28.67 (97.09)
9th (B4) Gear									
78.30 (58.39)	7506 (33.39)	3.91 (6.29)	2100	4.8	0.510 (0.310)	13.79 (2.72)	189 (87)	50 (10)	28.68 (97.12)
10th (C2) Gear									
78.93 (58.85)	6773 (30.13)	4.37 (7.03)	2100	4.2	0.504 (0.307)	13.94 (2.75)	189 (87)	54 (12)	28.65 (97.02)
11th (C3) Gear									
82.13 (61.24)	5844 (25.99)	5.27 (8.48)	2100	3.5	0.487 (0.296)	14.45 (2.85)	188 (87)	55 (13)	28.64 (96.99)
12th (D1) Gear									
79.16 (59.03)	4921 (21.89)	6.03 (9.70)	2100	3.1	0.504 (0.307)	13.94 (2.75)	189 (87)	56 (13)	28.64 (96.99)
13th (C4) Gear									
78.14 (58.27)	4502 (20.02)	6.51 (10.48)	2100	2.7	0.511 (0.311)	13.74 (2.71)	189 (87)	55 (13)	28.64 (96.99)
14th (D2) Gear									
76.65 (57.15)	3935 (17.50)	7.31 (11.76)	2100	2.4	0.520 (0.316)	13.52 (2.66)	189 (87)	55 (13)	28.64 (96.99)
15th (D3) Gear									
79.06 (58.96)	3378 (15.03)	8.78 (14.12)	2100	2.1	0.504 (0.306)	13.96 (2.75)	188 (87)	55 (13)	28.64 (96.99)

reverse 0.98 (1.57), 1.17 (1.89), 1.40 (2.26), 1.72 (2.77), 2.38 (3.83), 2.86 (4.61), 3.43 (5.52), 3.88 (6.24), 4.20 (6.76), 4.67 (7.51), 5.59 (9.00), 6.36 (10.24), 6.84 (11.02), 7.66 (12.33), 9.17 (14.76), 10.34 (16.64), 11.24 (18.09), 12.45 (20.03), 13.96 (22.46), 14.91 (23.99), 16.80 (27.04), 18.26 (29.39), 20.13 (32.39), 24.47 (39.68) **Clutch** multiple wet disc hydraulically operated by foot pedal **Brakes** wet disc hydraulically operated by two foot pedals which can be locked together **Steering** hydrostatic **Power take-off** 540 rpm at 1967 engine rpm or 1000 rpm at 1962 engine rpm **Unladen tractor mass** 10865 lb (4928 kg)

REPAIRS AND ADJUSTMENTS: No repairs or adjustments.

NOTE 1. The manufacturer declares that the average time between active regenerations is 100 hours, while operated in Auto Filter Cleaning Mode, at rated speed, full PTO load, under steady state conditions. A 4% power increase was observed during the active regeneration.

REMARKS: All test results were determined from observed data obtained in accordance with official OECD, SAE and Nebraska test procedures. For the maximum power tests the fuel temperature at the injection pump inlet was maintained at 119°F (46°C). The performance figures on this summary were taken from a test conducted under the OECD Code 2 test code procedure.

We, the undersigned, certify that this is a true and correct report of official Tractor Test No. **2076**, Nebraska Summary 892, January 13, 2014.

Roger M. Hoy
 Director

M.F. Kocher
 S. Pitla
 J.D. Luck
 Board of Tractor Test Engineers

TRACTOR SOUND LEVEL WITH CAB	Front Wheel Drive	
	Engaged dB(A)	Disengaged dB(A)
At no load in 10th (C2) Gear	66.6	66.8
Transport in 24th (F4) gear		71.9
Bystander in 23rd (F3) gear		78.8

TIRES AND WEIGHT

Rear Tires—No., size, ply & psi (kPa)
Front Tires—No., size, ply & psi (kPa)
Height of Drawbar
Static Weight with operator—Rear
 —Front
 —Total

Tested Without Ballast

Two 420/85R38; **; 12 (85)
 Two 380/85R24; **; 12 (85)
 19.5 in (495 mm)
 6850 lb (3107 kg)
 4190 lb (1901 kg)
 11040 lb (5008 kg)

DRAWBAR PERFORMANCE
Unballasted-Front Drive Engaged-1850 Engine RPM
MAXIMUM POWER IN SELECTED GEARS

Power Hp (kW)	Drawbar pull lbs (kN)	Speed mph (km/h)	Crank- shaft speed rpm	Slip %	Fuel Consumption lb/hp.hr (kg/kW.h)	Fuel Consumption Hp.hr/gal (kW.h/l)	Temp. °F(°C) cool- ing med	Air dry bulb	Barom. inch Hg (kPa)
6th (B2) Gear									
70.27 (52.40)	10726 (47.71)	2.46 (3.96)	2142	14.3	0.573 (0.348)	12.27 (2.42)	190 (88)	47 (8)	28.71 (97.22)
7th (B3) Gear									
81.04 (60.43)	10330 (45.95)	2.95 (4.74)	2043	10.0	0.501 (0.305)	14.02 (2.76)	190 (88)	47 (8)	28.70 (97.19)
8th (C1) Gear									
85.11 (63.46)	9951 (44.26)	3.21 (5.17)	1944	8.8	0.486 (0.296)	14.47 (2.85)	189 (87)	54 (12)	28.65 (97.02)
9th (B4) Gear									
86.20 (64.28)	9582 (42.62)	3.38 (5.43)	1866	7.6	0.479 (0.292)	14.66 (2.89)	189 (87)	51 (11)	28.68 (97.12)
10th (C2) Gear									
87.08 (64.93)	8661 (38.53)	3.77 (6.07)	1850	6.2	0.472 (0.287)	14.89 (2.93)	189 (87)	55 (13)	28.64 (96.99)
11th (C3) Gear									
90.25 (67.30)	7386 (32.85)	4.58 (7.37)	1850	4.8	0.454 (0.276)	15.47 (3.05)	190 (88)	55 (13)	28.64 (96.99)
12th (D1) Gear									
89.21 (66.52)	6357 (28.28)	5.26 (8.47)	1850	3.9	0.460 (0.280)	15.27 (3.01)	190 (88)	55 (13)	28.64 (96.99)
13th (C4) Gear									
88.53 (66.02)	5838 (25.97)	5.69 (9.15)	1850	3.5	0.463 (0.281)	15.20 (2.99)	190 (88)	56 (13)	28.63 (96.95)
14th (D2) Gear									
87.36 (65.14)	5126 (22.80)	6.39 (10.28)	1850	3.1	0.469 (0.285)	14.98 (2.95)	190 (88)	55 (13)	28.64 (96.99)
15th (D3) Gear									
89.04 (66.40)	4344 (19.32)	7.69 (12.38)	1850	2.6	0.460 (0.280)	15.26 (3.01)	190 (88)	55 (13)	28.64 (96.99)
16th (E1) Gear									
86.17 (64.26)	3718 (16.54)	8.70 (13.99)	1849	2.2	0.478 (0.291)	14.72 (2.90)	190 (88)	54 (12)	28.64 (96.99)

DRAWBAR PERFORMANCE
UNBALLASTED - FRONT DRIVE DISENGAGED
FUEL CONSUMPTION CHARACTERISTICS

Power Hp (kW)	Drawbar pull lbs (kN)	Speed mph (km/h)	Crank- shaft speed rpm	Slip %	Fuel Consumption lb/hp.hr (kg/kW.h)	Hp.hr/gal (kW.h/l)	Temp. °F cool- ing med	°C Air dry bulb	Barom. inch Hg (kPa)
Maximum Power—11th (C3) Gear									
81.19 (60.54)	5921 (26.34)	5.14 (8.27)	2100	5.1	0.491 (0.299)	14.30 (2.82)	189 (87)	56 (13)	28.64 (96.99)
75% of Pull at Maximum Power—11th (C3) Gear									
64.77 (48.30)	4442 (19.76)	5.47 (8.80)	2195	3.4	0.541 (0.329)	13.00 (2.56)	187 (87)	59 (15)	28.51 (96.55)
50% of Pull at Maximum Power—11th (C3) Gear									
43.84 (32.69)	2948 (13.11)	5.58 (8.97)	2215	2.4	0.640 (0.389)	10.99 (2.16)	187 (86)	59 (15)	28.51 (96.55)
75% of Pull at Reduced Engine Speed—14th (D2) Gear									
64.79 (48.31)	4445 (19.77)	5.47 (8.80)	1602	3.5	0.478 (0.291)	14.70 (2.90)	188 (87)	60 (15)	28.48 (96.44)
50% of Pull at Reduced Engine Speed—14th (D2) Gear									
43.81 (32.67)	2956 (13.15)	5.56 (8.95)	1612	2.4	0.535 (0.326)	13.14 (2.59)	187 (86)	60 (15)	28.48 (96.44)
MAXIMUM POWER IN SELECTED GEARS									
8th (C1) Gear									
71.70 (53.46)	8158 (36.29)	3.30 (5.31)	2150	14.4	0.564 (0.343)	12.47 (2.46)	189 (87)	53 (12)	28.65 (97.02)
9th (B4) Gear									
76.03 (56.70)	7628 (33.93)	3.74 (6.02)	2101	8.3	0.527 (0.321)	13.33 (2.63)	189 (87)	51 (10)	28.68 (97.12)
10th (C2) Gear									
77.42 (57.73)	6867 (30.55)	4.23 (6.81)	2101	6.6	0.516 (0.314)	13.61 (2.68)	188 (87)	55 (13)	28.64 (96.99)
11th (C3) Gear									
81.19 (60.54)	5921 (26.34)	5.14 (8.27)	2100	5.1	0.491 (0.299)	14.30 (2.82)	189 (87)	56 (13)	28.64 (96.99)
12th (D1) Gear									
79.11 (58.99)	5019 (22.33)	5.91 (9.51)	2100	4.2	0.506 (0.308)	13.90 (2.74)	189 (87)	56 (13)	28.63 (96.95)
13th (C4) Gear									
78.38 (58.45)	4600 (20.46)	6.39 (10.28)	2100	3.8	0.510 (0.310)	13.79 (2.72)	188 (87)	56 (13)	28.64 (96.99)
14th (D2) Gear									
77.11 (57.50)	4025 (17.90)	7.19 (11.56)	2100	3.2	0.514 (0.313)	13.66 (2.69)	189 (87)	55 (13)	28.64 (96.99)
15th (D3) Gear									
79.93 (59.60)	3467 (15.42)	8.65 (13.91)	2100	2.7	0.498 (0.303)	14.11 (2.78)	188 (87)	55 (13)	28.64 (96.99)

HYDRAULIC PERFORMANCE

CATEGORY: I/IN

Quick Attach: none

OECD Static test

Maximum force exerted through whole range: 4689 lbs (20.9 kN) (70 mm cylinders)
6152 lbs (27.4 kN) (80 mm cylinders)

Two outlet sets combined

35 cc pump 45 cc pump

i) Sustained pressure of the open relief valve:	2966 psi (204 bar)	2865 psi (198 bar)
ii) Pump delivery rate at minimum pressure and rated engine speed:	22.2 GPM (84.0 l/min)	30.5 GPM (115.6 l/min)
iii) Pump delivery rate at maximum hydraulic power:	22.3 GPM (84.4 l/min)	29.8 GPM (112.9 l/min)
Delivery pressure:	2673 psi (184 bar)	2607 psi (180 bar)
Power:	34.8 HP (25.9 kW)	45.4 HP (33.8 kW)

single outlet set

ii) Pump delivery rate at minimum pressure and rated engine speed:	22.1 GPM (83.8 l/min)	30.5 GPM (115.3 l/min)
iii) Pump delivery rate at maximum hydraulic power:	22.4 GPM (84.9 l/min)	30.6 GPM (115.9 l/min)
Delivery pressure:	2623 psi (181 bar)	2207 psi (152 bar)
Power:	34.3 HP (25.6 kW)	39.4 HP (29.4 kW)

HITCH DIMENSIONS AS TESTED—NO LOAD

	inch	mm
A	25.2	640
B	12.8	325
C	19.9	505
D	18.7	475
E	12.6	320
F	8.8	224
G	31.5	800
H	3.1	80
I	16.8	427
J	22.7	576
K	19.8	502
L	42.5	1080
M	21.7	550
N	37.2	945
O	9.1	231
P	49.6	1261
Q	36.2	920
R	30.1	765

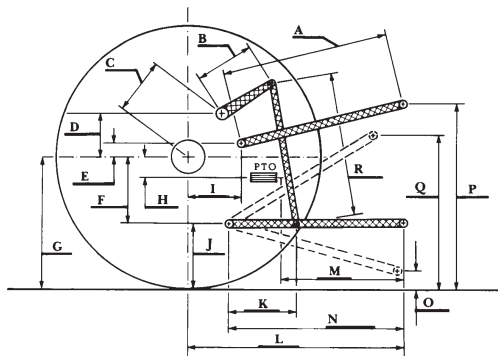

JOHN DEERE 6105M DIESEL

Institute of Agriculture and Natural Resources
University of Nebraska—Lincoln