

University of Nebraska - Lincoln

DigitalCommons@University of Nebraska - Lincoln

Nebraska Tractor Tests

Tractor Test and Power Museum, The Lester F.
Larsen

2013

Test 2077: John Deere 6115M

Nebraska Tractor Test Laboratory

University of Nebraska-Lincoln, tractortestlab@unl.edu

Follow this and additional works at: <https://digitalcommons.unl.edu/tractormuseumlit>



Part of the [Energy Systems Commons](#), [History of Science, Technology, and Medicine Commons](#), [Other Mechanical Engineering Commons](#), [Physical Sciences and Mathematics Commons](#), [Science and Mathematics Education Commons](#), and the [United States History Commons](#)

Laboratory, Nebraska Tractor Test, "Test 2077: John Deere 6115M" (2013). *Nebraska Tractor Tests*. 2479. <https://digitalcommons.unl.edu/tractormuseumlit/2479>

This Article is brought to you for free and open access by the Tractor Test and Power Museum, The Lester F. Larsen at DigitalCommons@University of Nebraska - Lincoln. It has been accepted for inclusion in Nebraska Tractor Tests by an authorized administrator of DigitalCommons@University of Nebraska - Lincoln.

NEBRASKA OECD TRACTOR TEST 2077—SUMMARY 893

JOHN DEERE 6115M POWRQUAD-PLUS DIESEL

24 SPEED

POWER TAKE-OFF PERFORMANCE

Power HP (kW)	Crank shaft speed rpm	Gal/hr (l/h)	lb/hp.hr (kg/kW.h)	Hp.hr/gal (kW.h/l)	Mean Atmospheric Conditions
MAXIMUM POWER AND FUEL CONSUMPTION					
Rated Engine Speed—(PTO speed—1071 rpm)					
96.38 (71.87)	2101	6.29 (23.83)	0.459 (0.279)	15.31 (3.02)	Fuel used during active exhaust regeneration - 0.54 gal (2.05 l) (see Note 1 p.2)
Standard Power Take-off Speed (1000 rpm)					
105.30 (78.52)	1962	6.48 (24.54)	0.433 (0.263)	16.24 (3.20)	
Maximum Power (1 hour)					
108.65 (81.02)	1801	6.49 (24.57)	0.420 (0.255)	16.74 (3.30)	

VARYING POWER AND FUEL CONSUMPTION

96.38 (71.87)	2101	6.29 (23.83)	0.459 (0.279)	15.31 (3.02)	Air temperature
84.44 (62.97)	2166	5.80 (21.94)	0.482 (0.293)	14.57 (2.87)	73°F (23°C)
64.33 (47.97)	2195	4.87 (18.43)	0.532 (0.324)	13.21 (2.60)	Relative humidity
43.32 (32.31)	2222	3.97 (15.03)	0.644 (0.392)	10.91 (2.15)	33%
21.95 (16.37)	2237	3.02 (11.43)	0.967 (0.588)	7.27 (1.43)	Barometer
0.93 (0.69)	2250	2.29 (8.68)	17.377 (10.570)	0.40 (0.08)	28.36" Hg (96.04 kPa)

Maximum Torque - 364 lb.-ft. (493 Nm) at 1401 rpm
 Maximum Torque rise - 51.0%
 Torque rise at 1681 engine rpm - 39%
 Power increase at 1801 rpm - 12.7%

DRAWBAR PERFORMANCE (Unballasted—Front Drive Engaged) FUEL CONSUMPTION CHARACTERISTICS

Power Hp (kW)	Drawbar pull lbs (kN)	Speed mph (km/h)	Crank- shaft speed rpm	Slip %	Fuel Consumption lb/hp.hr (kg/kW.h)	Hp.hr/gal (kW.h/l)	Temp. °F (°C) cool- ing med	Barom. inch Hg (kPa)
Maximum Power—11th (C3) Gear								
90.58 (67.55)	6450 (28.69)	5.27 (8.48)	2100	3.9	0.490 (0.298)	14.34 (2.82)	189 (87)	60 (16)
75% of Pull at Maximum Power—11th (C3) Gear								
71.91 (53.62)	4855 (21.60)	5.55 (8.93)	2194	3.0	0.541 (0.329)	13.00 (2.56)	189 (87)	57 (14)
50% of Pull at Maximum Power—11th (C3) Gear								
48.94 (36.49)	3243 (14.43)	5.66 (9.11)	2215	2.0	0.636 (0.387)	11.05 (2.18)	188 (86)	57 (14)
75% of Pull at Reduced Engine Speed—14th (D2) Gear								
71.85 (53.57)	4887 (21.74)	5.51 (8.87)	1590	3.0	0.478 (0.290)	14.72 (2.90)	188 (87)	55 (13)
50% of Pull at Reduced Engine Speed—14th (D2) Gear								
48.77 (36.36)	3253 (14.47)	5.62 (9.04)	1606	2.0	0.536 (0.326)	13.13 (2.59)	188 (86)	57 (14)

Location of tests: Nebraska Tractor Test Laboratory, University of Nebraska, Lincoln, Nebraska 68583-0832

Dates of tests: October 31 to November 15, 2013

Manufacturer: John Deere Werke Mannheim, John Deere StraBe 90, Mannheim, Germany

FUEL, OIL and Time: Fuel No. 2 Diesel Specific gravity converted to 60°/60°F (15°/15°C) 0.8442 Fuel weight 7.029 lbs/gal (0.842 kg/l) Oil SAE 10W-30 API service classification CJ-4 Transmission and hydraulic lubricant John Deere Hy-Gard II fluid Front axle lubricant John Deere Hy-Gard II fluid Total time engine was operated 19.5 hours.

ENGINE: Make John Deere Diesel **Type** four cylinder vertical with turbocharger and air to air intercooler **Serial No.** *CD4045R024533* **Crankshaft** lengthwise **Rated engine speed** 2100 **Bore and stroke** 4.19" x 5.00" (106.5 mm x 127.0 mm) **Compression ratio** 17.2 to 1 **Displacement** 276 cu in (4525 ml) **Starting system** 12 volt **Lubrication** pressure **Air cleaner** two paper elements **Oil filter** one full flow cartridge **Oil cooler** engine coolant heat exchanger for crankcase oil, engine coolant heat exchanger for hydraulic and transmission oil **Fuel filter** one paper element and one paper cartridge with water separator **Fuel cooler** radiator for pump return fuel **Exhaust** regenerative particulate filter integrated within an underhood muffler with vertical outlet **Cooling medium temperature control** two thermostats and variable speed fan

ENGINE OPERATING PARAMETERS: Fuel rate: 41.9 - 45.4 lb/h (19.0 - 20.6 kg/h) **High idle:** 2225 - 2275 rpm **Turbo boost:** nominal 17.4-20.3 psi (120-140 kPa) as measured 19.1 psi (131 kPa)

CHASSIS: Type front wheel assist **Serial No.** *1L06115MLDG764152* **Tread width** rear 63.5" (1612 mm) to 75.4" (1916 mm) front 62.4" (1584 mm) to 79.4" (2016 mm) **Wheel base** 101.6" (2580 mm) **Hydraulic control system** direct engine drive **Transmission** selective gear fixed ratio with partial (4) range operator controlled powershift **Nominal travel speeds mph (km/h)** first 0.93 (1.50) second 1.12 (1.81) third 1.35 (2.17) fourth 1.65 (2.65) fifth 2.28 (3.67) sixth 2.74 (4.42) seventh 3.29 (5.29) eighth 3.72 (5.98) ninth 4.03 (6.48) tenth 4.47 (7.20) eleventh 5.36 (8.62) twelfth 6.09 (9.81) thirteenth 6.56 (10.56) fourteenth 7.34 (11.81) fifteenth 8.79 (14.15) sixteenth 9.90 (15.94) seventeenth 10.77 (17.33) eighteenth 11.93 (19.20) nineteenth 13.37 (21.52) twentieth 14.29 (22.99) twenty-first 16.11 (25.92) twenty-second 17.50 (28.16) twenty-third 19.29 (31.04) twenty-fourth 23.63 (38.02)

DRAWBAR PERFORMANCE
Unballasted-Front Drive Engaged-2100 Engine RPM
MAXIMUM POWER IN SELECTED GEARS

Power Hp (kW)	Drawbar pull lbs (kN)	Speed mph (km/h)	Crank- shaft speed rpm	Slip %	Fuel Consumption lb/hp.hr (kg/kW.h)	Temp. °F(°C) cool- ing med	Barom. inch Hg (kPa)		
7th(B3) Gear									
80.74 (60.20)	10489 (46.66)	2.89 (4.65)	2098	14.1	0.553 (0.336)	12.72 (2.51)	191 (88)	62 (17)	28.50 (96.51)
8th(C1) Gear									
86.06 (64.17)	9198 (40.91)	3.51 (5.65)	2100	7.7	0.519 (0.315)	13.55 (2.67)	190 (88)	65 (18)	28.49 (96.48)
9th(B4) Gear									
85.70 (63.91)	8310 (36.96)	3.87 (6.23)	2100	6.1	0.518 (0.315)	13.57 (2.67)	191 (88)	64 (18)	28.50 (96.51)
10th(C2) Gear									
87.56 (65.29)	7542 (33.55)	4.36 (7.01)	2100	4.9	0.504 (0.307)	13.94 (2.75)	189 (87)	60 (16)	28.54 (96.65)
11th(C3) Gear									
90.58 (67.55)	6450 (28.69)	5.27 (8.48)	2100	3.9	0.490 (0.298)	14.34 (2.82)	189 (87)	60 (16)	28.54 (96.65)
12th(D1) Gear									
89.04 (66.39)	5538 (24.63)	6.03 (9.70)	2100	3.2	0.502 (0.305)	14.01 (2.76)	190 (88)	62 (17)	28.53 (96.61)
13th(C4) Gear									
87.56 (65.29)	5036 (22.40)	6.52 (10.49)	2100	2.7	0.509 (0.310)	13.80 (2.72)	189 (87)	56 (13)	28.60 (96.85)
14th(D2) Gear									
87.69 (65.39)	4495 (19.99)	7.32 (11.77)	2100	2.5	0.510 (0.310)	13.78 (2.71)	190 (88)	58 (14)	28.59 (96.81)
15th(D3) Gear									
88.14 (65.72)	3763 (16.74)	8.79 (14.14)	2100	2.2	0.505 (0.307)	13.92 (2.74)	190 (88)	64 (18)	28.49 (96.47)

reverse 0.98 (1.57), 1.17 (1.89), 1.40 (2.26), 1.72 (2.77), 2.38 (3.83), 2.86 (4.61), 3.43 (5.52), 3.88 (6.24), 4.20 (6.76), 4.67 (7.51), 5.59 (9.00), 6.36 (10.24), 6.84 (11.02), 7.66 (12.33), 9.17 (14.76), 10.34 (16.64), 11.24 (18.09), 12.45 (20.03), 13.96 (22.46), 14.91 (23.99), 16.80 (27.04), 18.26 (29.39), 20.13 (32.39), 24.47 (39.68) **Clutch** multiple wet disc hydraulically operated by foot pedal **Brakes** wet disc hydraulically operated by two foot pedals which can be locked together **Steering** hydrostatic **Power take-off** 540 rpm at 1967 engine rpm or 1000 rpm at 1962 engine rpm. **Unladen tractor mass** 10815 lb (4906 kg)

REPAIRS AND ADJUSTMENTS: No repairs or adjustments.

NOTE 1. The manufacturer declares that the average time between active regenerations is 100 hours, while operated in Auto Filter Cleaning Mode, at rated speed, full PTO load, under steady state conditions.

REMARKS: All test results were determined from observed data obtained in accordance with official OECD, SAE and Nebraska test procedures. For the maximum power tests the fuel temperature at the injection pump inlet was maintained at 121°F (49°C). The performance figures on this summary were taken from a test conducted under the OECD Code 2 test code procedure.

We, the undersigned, certify that this is a true and correct report of official Tractor Test No. **2077**, Nebraska Summary 893, January 13, 2014.

Roger M. Hoy
 Director

M.F. Kocher
 S. Pitla
 J.D. Luck
 Board of Tractor Test Engineers

TRACTOR SOUND LEVEL WITH CAB

	Front Wheel Drive	
	Engaged dB(A)	Disengaged dB(A)
At no load in 10th(C2) Gear	66.1	65.8
Transport in 24th(F4) gear		71.7
Bystander in 23rd(F3) gear		77.5

TIRES AND WEIGHT

Rear Tires -No., size, ply & psi (kPa)	Two 420/85R38;**, 12 (85)
Front Tires -No., size, ply & psi (kPa)	Two 380/85R24;**, 12 (85)
Height of Drawbar	19.5 in (495 mm)
Static Weight with operator - Rear	6830 lb (3098 kg)
- Front	4160 lb (1887 kg)
- Total	10990 lb (4985 kg)

Tested Without Ballast

DRAWBAR PERFORMANCE
Unballasted-Front Drive Engaged-1800 Engine RPM
MAXIMUM POWER IN SELECTED GEARS

Power Hp (kW)	Drawbar pull lbs (kN)	Speed mph (km/h)	Crank- shaft speed rpm	Slip %	Fuel Consumption lb/hp.hr (kg/kW.h)	Fuel Consumption Hp.hr/gal (kW.h/l)	Temp. °F(°C) cool- ing med	Air dry bulb	Barom. inch Hg (kPa)
7th (B3) Gear									
80.95 (60.36)	10544 (46.90)	2.88 (4.63)	2089	13.9	0.551 (0.335)	12.76 (2.51)	191 (88)	63 (17)	28.49 (96.48)
8th (C1) Gear									
88.67 (66.12)	10028 (44.61)	3.32 (5.33)	2034	9.9	0.515 (0.314)	13.64 (2.69)	192 (89)	61 (16)	28.50 (96.51)
9th (B4) Gear									
90.39 (67.40)	9451 (42.04)	3.59 (5.78)	1997	8.3	0.512 (0.311)	13.74 (2.71)	193 (89)	64 (18)	28.50 (96.51)
10th (C2) Gear									
93.82 (69.96)	9087 (40.42)	3.88 (6.24)	1919	7.4	0.488 (0.297)	14.39 (2.84)	192 (89)	64 (18)	28.50 (96.51)
11th (C3) Gear									
98.67 (73.58)	8375 (37.25)	4.42 (7.11)	1800	6.0	0.465 (0.283)	15.11 (2.98)	193 (89)	61 (16)	28.55 (96.68)
12th (D1) Gear									
99.04 (73.85)	7299 (32.47)	5.09 (8.19)	1800	4.9	0.464 (0.282)	15.14 (2.98)	194 (90)	62 (17)	28.50 (96.51)
13th (C4) Gear									
98.16 (73.20)	6663 (29.64)	5.53 (8.89)	1800	3.9	0.469 (0.285)	14.99 (2.95)	190 (88)	57 (14)	28.59 (96.81)
14th (D2) Gear									
98.53 (73.47)	5951 (26.47)	6.21 (9.99)	1800	3.4	0.468 (0.284)	15.04 (2.96)	191 (88)	59 (15)	28.56 (96.72)
15th (D3) Gear									
98.53 (73.47)	4943 (21.99)	7.48 (12.04)	1800	2.9	0.466 (0.283)	15.09 (2.97)	190 (88)	63 (17)	28.49 (96.48)
16th (E1) Gear									
96.59 (72.02)	4281 (19.04)	8.46 (13.62)	1800	2.5	0.475 (0.289)	14.80 (2.91)	192 (89)	63 (17)	28.49 (96.48)

DRAWBAR PERFORMANCE
UNBALLASTED - FRONT DRIVE DISENGAGED
FUEL CONSUMPTION CHARACTERISTICS

Power Hp (kW)	Drawbar pull lbs (kN)	Speed mph (km/h)	Crank- shaft speed rpm	Slip %	Fuel Consumption lb/hp.hr (kg/kW.h)	Fuel Consumption Hp.hr/gal (kW.h/l)	Temp. °F cool- ing med	Temp. °C (°C) Air dry bulb	Barom. inch Hg (kPa)
Maximum Power—11th (C3) Gear									
88.65 (66.11)	6518 (28.99)	5.10 (8.21)	2100	6.1	0.502 (0.305)	14.00 (2.76)	189 (87)	61 (16)	28.55 (96.68)
75% of Pull at Maximum Power—11th (C3) Gear									
71.25 (51.13)	4908 (21.83)	5.45 (8.76)	2195	4.1	0.544 (0.331)	12.93 (2.55)	189 (87)	57 (14)	28.87 (97.77)
50% of Pull at Maximum Power—11th (C3) Gear									
48.90 (36.46)	3291 (14.64)	5.57 (8.96)	2215	2.8	0.632 (0.384)	11.12 (2.19)	188 (87)	57 (14)	28.87 (97.77)
75% of Pull at Reduced Engine Speed—14th (D2) Gear									
71.23 (53.12)	4943 (21.99)	5.41 (8.70)	1591	4.2	0.480 (0.292)	14.66 (2.89)	189 (87)	55 (13)	28.86 (97.73)
50% of Pull at Reduced Engine Speed—14th (D2) Gear									
48.74 (36.35)	3302 (14.69)	5.54 (8.92)	1606	2.7	0.531 (0.323)	13.23 (2.61)	188 (87)	56 (13)	28.86 (97.73)
MAXIMUM POWER IN SELECTED GEARS									
9th (B4) Gear									
76.78 (57.25)	7875 (35.03)	3.66 (5.89)	2173	13.4	0.580 (0.353)	12.12 (2.39)	191 (88)	65 (18)	28.50 (96.51)
10th (C2) Gear									
82.94 (61.85)	7631 (33.94)	4.08 (6.56)	2101	10.1	0.536 (0.326)	13.11 (2.58)	191 (88)	64 (18)	28.50 (96.51)
11th (C3) Gear									
88.65 (66.11)	6518 (28.99)	5.10 (8.21)	2100	6.1	0.502 (0.305)	14.00 (2.76)	189 (87)	61 (16)	28.55 (96.68)
12th (D1) Gear									
87.91 (65.55)	5609 (24.95)	5.88 (9.46)	2100	4.8	0.509 (0.310)	13.81 (2.72)	189 (87)	62 (17)	28.51 (96.54)
13th (C4) Gear									
87.87 (65.52)	5155 (22.93)	6.39 (10.28)	2100	3.9	0.509 (0.309)	13.82 (2.72)	189 (87)	57 (14)	28.59 (96.82)
14th (D2) Gear									
87.60 (65.32)	4573 (20.34)	7.19 (11.56)	2100	3.4	0.510 (0.310)	13.78 (2.71)	188 (87)	58 (15)	28.58 (96.78)
15th (D3) Gear									
88.39 (65.91)	3842 (17.09)	8.63 (13.88)	2099	3.1	0.501 (0.305)	14.03 (2.76)	190 (88)	63 (17)	28.48 (96.44)

HYDRAULIC PERFORMANCE

CATEGORY: I/IN

Quick Attach: none

OECD Static test

Maximum force exerted through whole range: 5345 lbs (23.8 kN) (75 mm cylinders)
7130 lbs (31.7 kN) (85 mm cylinders)

Two outlet sets combined

	35 cc pump	45 cc pump
i) Sustained pressure of the open relief valve:	2966 psi (204 bar)	2865 psi (198 bar)
ii) Pump delivery rate at minimum pressure and rated engine speed:	22.2 GPM (84.0 l/min)	30.5 GPM (115.6 l/min)
iii) Pump delivery rate at maximum hydraulic power:	22.3 GPM (84.4 l/min)	29.8 GPM (112.9 l/min)
Delivery pressure:	2673 psi (184 bar)	2607 psi (180 bar)
Power:	34.8 HP (25.9 kW)	45.4 HP (33.8 kW)

single outlet set

ii) Pump delivery rate at minimum pressure and rated engine speed:	22.1 GPM (83.8 l/min)	30.5 GPM (115.3 l/min)
iii) Pump delivery rate at maximum hydraulic power:	22.4 GPM (84.9 l/min)	30.6 GPM (115.9 l/min)
Delivery pressure:	2623 psi (181 bar)	2207 psi (152 bar)
Power:	34.3 HP (25.6 kW)	39.4 HP (29.4 kW)

HITCH DIMENSIONS AS TESTED—NO LOAD

	inch	mm
A	25.2	640
B	12.8	325
C	19.9	505
D	18.7	475
E	12.6	320
F	8.8	224
G	31.5	800
H	3.1	80
I	16.8	427
J	22.7	576
K	19.8	502
L	42.5	1080
M	21.7	550
N	37.2	945
O	9.1	231
P	49.6	1261
Q	36.2	920
R	30.1	765

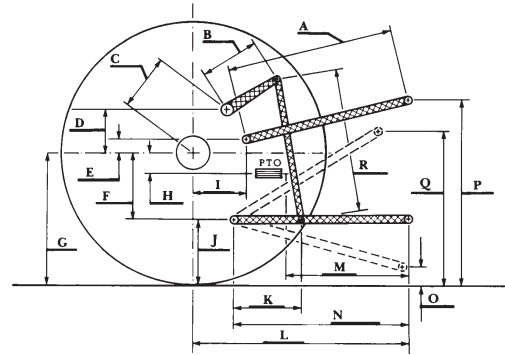

JOHN DEERE 6115M DIESEL

Institute of Agriculture and Natural Resources
University of Nebraska—Lincoln