

University of Nebraska - Lincoln

DigitalCommons@University of Nebraska - Lincoln

---

Nebraska Tractor Tests

Tractor Test and Power Museum, The Lester F.  
Larsen

---

2016

## Test 2150A: New Holland T8.435 SmartTrax

Nebraska Tractor Test Lab

University of Nebraska-Lincoln, [tractortestlab@unl.edu](mailto:tractortestlab@unl.edu)

Follow this and additional works at: <https://digitalcommons.unl.edu/tractormuseumlit>



Part of the [Energy Systems Commons](#), [History of Science, Technology, and Medicine Commons](#), [Other Mechanical Engineering Commons](#), [Physical Sciences and Mathematics Commons](#), [Science and Mathematics Education Commons](#), and the [United States History Commons](#)

---

Nebraska Tractor Test Lab, "Test 2150A: New Holland T8.435 SmartTrax" (2016). *Nebraska Tractor Tests*. 2615.

<https://digitalcommons.unl.edu/tractormuseumlit/2615>

This Article is brought to you for free and open access by the Tractor Test and Power Museum, The Lester F. Larsen at DigitalCommons@University of Nebraska - Lincoln. It has been accepted for inclusion in Nebraska Tractor Tests by an authorized administrator of DigitalCommons@University of Nebraska - Lincoln.

# NEBRASKA OECD TRACTOR TEST 2150A—SUMMARY 1013A

## NEW HOLLAND T8.435 SMARTTRAX DIESEL CVT TRANSMISSION

### POWER TAKE-OFF PERFORMANCE

Power HP (kW)	Crank shaft speed rpm	Diesel Consumption		D.E.F. Consumption		Mean Atmospheric Conditions
		Gal/hr (l/h)	lb/hp.hr (kg/kWh)	Hp.hr/gal (kW.h/l)	Gal/hr (l/h)	
<b>MAXIMUM POWER AND FUEL CONSUMPTION</b>						
<b>Rated Engine Speed—(PTO speed—1124 rpm)</b>						
321.73 (239.91)	2000	17.09 (64.68)	0.372 (0.226)	18.83 (3.71)	1.78 (6.74)	
<b>Power at 1800 engine rpm (1 hour)</b>						
375.67 (280.14)	1800	19.61 (74.23)	0.366 (0.223)	19.16 (3.77)	1.71 (6.48)	
<b>Standard Power Take-off Speed (1000 rpm)</b>						
375.75 (280.19)	1779	19.53 (73.95)	0.364 (0.222)	19.23 (3.79)	1.74 (6.57)	

### VARYING POWER AND FUEL CONSUMPTION

321.73 (239.91)	2000	17.09 (64.68)	0.372 (0.226)	18.83 (3.71)	1.78 (6.74)	Air temperature
289.37 (215.78)	2116	15.98 (60.49)	0.387 (0.235)	18.11 (3.57)	1.45 (5.47)	74°F (23°C)
220.07 (164.11)	2145	12.74 (48.22)	0.406 (0.247)	17.28 (3.40)	1.06 (4.00)	Relative humidity
149.08 (111.17)	2181	9.62 (36.41)	0.452 (0.275)	15.50 (3.05)	0.70 (2.67)	48%
75.10 (56.00)	2202	6.41 (24.27)	0.598 (0.364)	11.71 (2.31)	0.41 (1.53)	Barometer
2.18 (1.63)	2218	3.45 (13.07)	11.093 (6.747)	0.63 (0.12)	0.18 (0.68)	28.21" Hg (95.53 kPa)

Maximum torque - 1254 lb.-ft. (1700 Nm) at 1400 rpm  
 Maximum torque rise - 48.4%  
 Torque rise at 1599 engine rpm - 42%  
 Power increase at 1800 engine rpm - 16.8%

### DRAWBAR PERFORMANCE

#### UNBALLASTED - FRONT DRIVE ENGAGED FUEL CONSUMPTION CHARACTERISTICS

Power Hp (kW)	Drawbar pull lbs (kN)	Speed mph (km/h)	Crank- shaft speed rpm	Slip %	Fuel Consumption lb/hp.hr (kg/kWh)	D.E.F. Consumption Hp.hr/gal (kW.h/l)	Temp. °F(°C) cool- ing med bulb	Air dry bulb	Barom. inch Hg (kPa)	
<b>Power at Rated Engine Speed—5.6 mph (9.0 km/h)-Manual mode</b>										
252.66 (188.41)	17509 (77.88)	5.41 (8.71)	2000	2.8	0.474 (0.288)	14.79 (2.91)	0.065 (0.040)	215 (101)	50 (10)	28.65 (97.02)
<b>75% of Pull at Rated Engine Speed—5.6 mph (9.0 km/h)-Manual mode</b>										
190.67 (142.18)	13056 (58.07)	5.48 (8.82)	2136	1.7	0.512 (0.312)	13.68 (2.69)	0.053 (0.032)	196 (91)	53 (11)	28.74 (97.32)
<b>50% of Pull at Rated Engine Speed—5.6 mph (9.0 km/h)-Manual mode</b>										
127.96 (95.42)	8701 (38.70)	5.52 (8.88)	2174	1.0	0.584 (0.355)	11.99 (2.36)	0.054 (0.033)	186 (86)	53 (12)	28.74 (97.32)
<b>75% of Pull at Reduced Engine Speed—Auto mode</b>										
190.53 (142.07)	13059 (58.09)	5.47 (8.80)	1510	1.7	0.464 (0.282)	15.10 (2.97)	0.050 (0.031)	193 (89)	53 (12)	28.74 (97.32)
<b>50% of Pull at Reduced Engine Speed—Auto mode</b>										
127.80 (95.30)	8704 (38.72)	5.51 (8.87)	1363	1.0	0.498 (0.303)	14.07 (2.77)	0.054 (0.033)	185 (85)	53 (12)	28.75 (97.36)

**Location of tests:** Nebraska Tractor Test Laboratory, University of Nebraska, Lincoln, Nebraska 68583-0832

**Dates of tests:** April 27 to May 3, 2016

**Manufacturer:** CNH Industrial America LLC, 700 State St. Racine, Wi. 53404 USA

**CONSUMABLE Fluids, OIL and TIME: Fuel** No. 2 Diesel **Specific gravity converted to 60°/60°F (15°/15°C)** 0.8417 **Fuel weight** 7.008 lbs/gal (0.840 kg/l) **Diesel Exhaust Fluid (DEF)** 32% aqueous urea solution **DEF weight** 9.071 lbs/gal (1.087 kg/l) **Oil SAE 10W40 API service classification CJ-4 Transmission and hydraulic lubricant** New Holland Ambra Mastertran fluid **Front axle lubricant** SAE 85W-140 API GL-5 **Total time engine was operated:** 19.5 hours

**ENGINE: Make** F.P.T. Diesel **Type** six cylinder vertical with turbocharger, air to air intercooler and D.E.F. (diesel exhaust fluid) exhaust treatment **Serial No.** \*15H00120734\* **Crankshaft** lengthwise **Rated engine speed** 2000 **Bore and stroke** 4.606" x 5.315" (117.0 mm x 135.0 mm) **Compression ratio** 15.9 to 1 **Displacement** 531 cu in (8704 ml) **Starting system** 12 volt **Lubrication** pressure **Air cleaner** two paper elements and aspirator **Oil filter** one full flow cartridge **Oil cooler** engine coolant heat exchanger for crankcase oil, radiator for hydraulic and transmission oil **Fuel filter** two paper elements **Fuel cooler** radiator for pump return fuel **Exhaust** DOC (diesel oxidation catalyst) and SCR (selective catalyst reduction) integrated within a vertical muffler **Cooling medium temperature control** 2 thermostats and variable speed fan

**ENGINE OPERATING PARAMETERS: Fuel rate:** 116.4 - 129.4 lb/h (52.8 - 58.7 kg/h) **High idle:** 2215 - 2265 rpm **Turbo boost:** nominal 26.1 - 29.0 psi (180 - 200 kPa) as measured 28.2 psi (194 kPa)

**CHASSIS: Type** Half track drive, front wheel assist with rear rubber tracks **Serial No.** \*ZGRF01272\* **Tread width** rear 120.0" (3050 mm) front 68.0" (1725 mm) to 88.0" (2235 mm) **Wheelbase** 140.0" (3550 mm) **Length of track on ground** 29.4" (748 mm) **Hydraulic control system** direct engine drive **Transmission** Infinitely variable with four mechanical ranges and automatic shifting between ranges. **Nominal travel speeds mph (km/h)** forward - 0 - 18.6 mph, (0 - 30 km/h) reverse - 0 - 14.9 mph, (0-24 km/h) **Clutch** a foot pedal controls the hydrostatic oil flow **Brakes** wet disc hydraulically operated by two foot pedals that can be locked together **Steering** hydrostatic **Power take-off** 1000 rpm at 1778 engine rpm **Unladen tractor mass** 38225 lb (17338 kg)

**DRAWBAR PERFORMANCE**  
**UNBALLASTED - FRONT DRIVE ENGAGED**

**MANUAL MODE - 2000 ENGINE RPM**  
**DRAWBAR POWER AT SELECTED TRAVEL SPEED SETTINGS**

Power Hp (kW)	Drawbar pull lbs (kN)	Speed mph (km/h)	Crank- shaft speed rpm	Slip %	Fuel Consumption lb/hp.hr (kg/kW.h)	Hp.hr/gal Consumption (kW.h/l)	D.E.F. Consumption lb/hp.hr (kg/kW.h)	Temp.°F(°C) cool- ing med	Air dry bulb	Barom. inch Hg (kPa)
2.4 mph (3.8 km/h)										
186.96 (139.41)	34131 (151.82)	2.06 (3.31)	1994	12.6	0.638 (0.388)	10.98 (2.16)	0.084 (0.051)	194 (90)	47 (9)	28.80 (97.53)
3.0 mph (4.8 km/h)										
215.78 (160.91)	29596 (131.65)	2.73 (4.39)	2000	7.9	0.555 (0.338)	12.63 (2.49)	0.073 (0.044)	190 (88)	48 (9)	28.82 (97.59)
3.6 mph (5.8 km/h)										
233.16 (173.87)	25871 (115.08)	3.38 (5.44)	2000	5.9	0.514 (0.313)	13.64 (2.69)	0.068 (0.041)	193 (89)	48 (9)	28.84 (97.66)
4.2 mph (6.7 km/h)										
245.82 (183.31)	23316 (103.71)	3.95 (6.36)	2000	4.6	0.486 (0.295)	14.43 (2.84)	0.065 (0.040)	201 (94)	48 (9)	28.82 (97.60)
4.7 mph (7.5 km/h)										
246.60 (183.89)	20719 (92.16)	4.46 (7.18)	2000	3.7	0.486 (0.295)	14.43 (2.84)	0.065 (0.040)	203 (95)	51 (11)	28.67 (97.09)
5.2 mph (8.3 km/h)										
250.69 (186.94)	18912 (84.12)	4.97 (8.00)	2000	3.1	0.477 (0.290)	14.70 (2.90)	0.065 (0.040)	211 (99)	50 (10)	28.66 (97.05)
5.6 mph (9.0 km/h)										
252.66 (188.41)	17509 (77.88)	5.41 (8.71)	2000	2.8	0.474 (0.288)	14.79 (2.91)	0.065 (0.040)	215 (101)	50 (10)	28.65 (97.02)
6.2 mph (10.0 km/h)										
252.70 (188.43)	15691 (69.79)	6.04 (9.72)	2000	2.3	0.473 (0.288)	14.81 (2.92)	0.065 (0.040)	215 (102)	52 (11)	28.68 (97.12)
6.8 mph (11.0 km/h)										
251.42 (187.48)	14130 (62.85)	6.67 (10.73)	2000	1.9	0.475 (0.289)	14.76 (2.91)	0.064 (0.039)	213 (101)	52 (11)	28.72 (97.26)
7.5 mph (12.0 km/h)										
247.70 (184.71)	12726 (56.61)	7.30 (11.75)	2000	1.6	0.483 (0.294)	14.52 (2.86)	0.065 (0.040)	211 (99)	53 (12)	28.71 (97.22)
8.1 mph (13.0 km/h)										
242.50 (180.83)	11468 (51.01)	7.93 (12.76)	2000	1.3	0.494 (0.301)	14.18 (2.79)	0.066 (0.040)	209 (98)	53 (12)	28.71 (97.22)
8.7 mph (14.0 km/h)										
235.40 (175.54)	10371 (46.13)	8.51 (13.70)	2000	1.2	0.507 (0.308)	13.83 (2.72)	0.067 (0.041)	205 (96)	53 (11)	28.72 (97.25)

TRACTOR SOUND LEVEL WITH CAB	Front Wheel Drive	
	Engaged dB(A)	Disengaged dB(A)
At no load at 4.6 mph (7.5 km/h) engine speed 2210 rpm	68.8	68.8
At no load at 4.6 mph (7.5 km/h) engine speed 1300 rpm	67.6	67.5
Bystander		90.1

**TIRES AND WEIGHT**

**Rear Tracks** - No. & size  
**Front Tires** - No., size, ply & psi (kPa)  
**Height of Drawbar**  
**Static Weight with operator** - Rear  
 - Front  
 - Total

**Tested Without Ballast**  
 2 x 18 in (455 mm)  
 Two 420/85R38;\*\*\*;23(160)  
 21.5 in (545 mm)  
 26750 lb (12134 kg)  
 11650 lb (5284 kg)  
 38400 lb (17418 kg)

**REPAIRS AND ADJUSTMENTS:** No repairs or adjustments.

**NOTE:** The data on this summary was obtained from testing conducted on the Case IH Magnum 380 Rowtrac Diesel.

**REMARKS:** All test results were determined from observed data obtained in accordance with official OECD, SAE and Nebraska test procedures. This tractor did not meet the manufacturer's remote hydraulic flow of 44 GPM (166 l/min) with standard pump. The manufacturer's remote flow claim of 75 GPM (282 l/min), with MegaFlow option, was not verified. The performance figures on this summary were taken from a test conducted under the OECD Code 2 test procedure.

We, the undersigned, certify that this is a true and correct report of official Tractor Test No. **2150A**, Nebraska Summary 1013A, June 10, 2016.

Roger M. Hoy  
 Director

M.F. Kocher  
 J.D. Luck  
 P.J. Jasa  
 Board of Tractor Test Engineers

**DRAWBAR PERFORMANCE**  
**UNBALLASTED - FRONT DRIVE ENGAGED**

AUTOMATIC MODE(Loads based on 2000 engine rpm manual mode performance runs)

**DRAWBAR POWER AT SELECTED TRAVEL SPEED SETTINGS**

Power Hp (kW)	Drawbar pull lbs (kN)	Speed mph (km/h)	Crank- shaft speed rpm	Slip %	Fuel Consumption lb/hp.hr (kg/kW.h)	Hp.hr/gal (kW.h/l)	D.E.F. Consumption lb/hp.hr (kg/kW.h)	Temp. °F(°C) cool- ing med	Air dry bulb	Barom. inch Hg (kPa)
3.6mph(5.8km/h)										
232.91 (173.68)	25796 (114.75)	3.39 (5.45)	1629	5.8	0.470 (0.286)	14.92 (2.94)	0.060 (0.036)	189 (87)	48 (9)	28.83 (97.63)
4.2mph(6.7 km/h)										
246.00 (183.44)	23309 (103.68)	3.96 (6.37)	1654	4.5	0.470 (0.286)	14.90 (2.94)	0.058 (0.036)	193 (89)	48 (9)	28.85 (97.70)
4.7mph(7.5 km/h)										
246.55 (183.85)	20694 (92.05)	4.47 (7.19)	1637	3.7	0.459 (0.279)	15.27 (3.01)	0.058 (0.035)	197 (91)	52 (11)	28.67 (97.09)
5.2mph(8.3 km/h)										
250.64 (186.90)	18913 (84.13)	4.97 (8.00)	1634	3.2	0.454 (0.276)	15.45 (3.04)	0.057 (0.035)	202 (94)	51 (11)	28.66 (97.05)
5.6mph(9.0 km/h)										
252.43 (188.23)	17477 (77.74)	5.42 (8.72)	1645	2.8	0.454 (0.276)	15.44 (3.04)	0.058 (0.035)	208 (98)	50 (10)	28.67 (97.09)
6.2mph(10.0 km/h)										
252.19 (188.05)	15641 (69.57)	6.05 (9.74)	1640	2.2	0.456 (0.278)	15.36 (3.03)	0.060 (0.036)	207 (97)	52 (11)	28.70 (97.19)
6.8mph(11.0 km/h)										
251.78 (187.75)	14139 (62.89)	6.68 (10.74)	1659	1.9	0.461 (0.281)	15.19 (2.99)	0.058 (0.035)	206 (97)	52 (11)	28.71 (97.22)
7.5mph(12.0 km/h)										
248.20 (185.08)	12738 (56.66)	7.31 (11.76)	1669	1.6	0.457 (0.278)	15.34 (3.02)	0.059 (0.036)	205 (96)	53 (11)	28.72 (97.26)
8.1mph(13.0 km/h)										
242.64 (180.93)	11467 (51.01)	7.94 (12.77)	1676	1.3	0.456 (0.277)	15.37 (3.03)	0.059 (0.036)	206 (97)	53 (11)	28.71 (97.22)
8.7mph(14.0 km/h)										
235.10 (175.31)	10294 (45.79)	8.57 (13.78)	1651	1.2	0.455 (0.277)	15.41 (3.04)	0.058 (0.035)	202 (94)	52 (11)	28.71 (97.22)

**DRAWBAR PERFORMANCE**  
**UNBALLASTED - FRONT DRIVE ENGAGED**  
**MANUAL MODE - 1800 ENGINE RPM**  
**MAXIMUM POWER AT SELECTED TRAVEL SPEED SETTINGS**

Power Hp (kW)	Drawbar pull lbs (kN)	Speed mph (km/h)	Crank- shaft speed rpm	Slip %	Fuel Consumption lb/hp.hr (kg/kW.h)	Hp.hr/gal (kW.h/l)	D.E.F. Consumption lb/hp.hr (kg/kW.h)	Temp. °F(°C) cool- ing dry med	Air dry bulb	Barom. inch Hg (kPa)
2.4 mph (3.8 km/h)										
186.07 (138.75)	34315 (152.64)	2.04 (3.28)	1989	13.3	0.648 (0.394)	10.81 (2.13)	0.085 (0.052)	190 (88)	47 (9)	28.82 (97.60)
3.0 mph (4.8 km/h)										
222.27 (165.75)	32418 (144.20)	2.58 (4.14)	1938	10.7	0.570 (0.347)	12.29 (2.42)	0.072 (0.044)	190 (88)	48 (9)	28.84 (97.66)
3.6 mph (5.8 km/h)										
250.52 (186.81)	30485 (135.60)	3.09 (4.96)	1881	8.7	0.522 (0.318)	13.42 (2.64)	0.063 (0.039)	194 (90)	48 (9)	28.82 (97.60)
4.2 mph (6.7 km/h)										
271.54 (202.48)	28764 (127.95)	3.54 (5.70)	1845	7.5	0.493 (0.300)	14.21 (2.80)	0.058 (0.036)	199 (93)	49 (9)	28.82 (97.60)
4.7 mph (7.5 km/h)										
276.56 (206.23)	26426 (117.55)	3.93 (6.32)	1802	6.1	0.496 (0.302)	14.13 (2.78)	0.056 (0.034)	203 (95)	49 (9)	28.83 (97.62)
5.2 mph (8.3 km/h)										
286.02 (213.29)	24468 (108.84)	4.39 (7.06)	1800	5.1	0.481 (0.292)	14.58 (2.87)	0.055 (0.034)	213 (100)	51 (10)	28.66 (97.05)
5.6 mph (9.0 km/h)										
291.72 (217.54)	22833 (101.56)	4.79 (7.71)	1800	4.5	0.471 (0.287)	14.87 (2.93)	0.055 (0.033)	217 (103)	50 (10)	28.63 (96.95)
6.2 mph (10.0 km/h)										
295.43 (220.30)	20659 (91.90)	5.36 (8.63)	1800	3.6	0.465 (0.283)	15.06 (2.97)	0.055 (0.034)	213 (101)	52 (11)	28.71 (97.22)
6.8 mph (11.0 km/h)										
297.05 (221.51)	18759 (83.44)	5.94 (9.56)	1800	3.0	0.462 (0.281)	15.17 (2.99)	0.053 (0.032)	214 (101)	52 (11)	28.71 (97.22)
7.5 mph (12.0 km/h)										
296.31 (220.95)	17075 (75.95)	6.51 (10.48)	1800	2.6	0.463 (0.282)	15.13 (2.98)	0.053 (0.032)	214 (101)	53 (12)	28.73 (97.29)
8.1 mph (13.0 km/h)										
294.19 (219.38)	15582 (69.31)	7.08 (11.39)	1800	2.2	0.466 (0.283)	15.05 (2.97)	0.053 (0.032)	214 (101)	53 (11)	28.70 (97.19)
8.7 mph (14.0 km/h)										
289.96 (216.22)	14294 (63.58)	7.61 (12.25)	1800	1.9	0.473 (0.288)	14.82 (2.92)	0.054 (0.033)	211 (99)	52 (11)	28.71 (97.22)
9.3 mph (15.0 km/h)										
297.66 (221.97)	13602 (60.50)	8.21 (13.21)	1800	1.7	0.460 (0.280)	15.22 (3.00)	0.053 (0.032)	219 (104)	52 (11)	28.73 (97.29)

## HYDRAULIC PERFORMANCE

CATEGORY: 4N	
Quick Attach: Yes	
OECD Static test	
Maximum force exerted through whole range:	20012 lbs (89.0 kN)
	<b>Standard pump</b>
	<u>three outlet sets combined</u>
i) Sustained pressure at compensator cutoff:	2912 psi (201 bar)
ii) Pump delivery rate at minimum pressure and rated engine speed:	42.7 GPM (161.7 l/min)
iii) Pump delivery rate at maximum	
hydraulic power:	42.1 GPM (159.4 l/min)
Delivery pressure:	2752 psi (190 bar)
Power:	67.6 HP (50.4 kW)
	<b>single outlet set</b>
i) Sustained pressure at compensator cutoff:	2917 psi (201 bar)
ii) Pump delivery rate at minimum pressure and rated engine speed:	41.8 GPM (158.3 l/min)
iii) Pump delivery rate at maximum	
hydraulic power:	42.4 GPM (160.4 l/min)
Delivery pressure:	2175 psi (150 bar)
Power:	53.8 HP (40.1 kW)

## HITCH DIMENSIONS AS TESTED—NO LOAD

	inch	mm
A	29.7	755
B	20.5	520
C	22.9	581
D	23.4	595
E	13.2	336
F	11.6	295
G	33.8	860
*G'	14.6	370
H	0.8	20
I	20.9	530
J	22.2	565
K	30.2	768
L	53.1	1350
*L'	60.4	1534
M	27.2	691
N	38.2	970
O	10.4	265
P	49.8	1265
Q	42.3	1075
R	40.7	1035

\*G' to undercarriage pivot point  
\*L' to Quick coupler ends

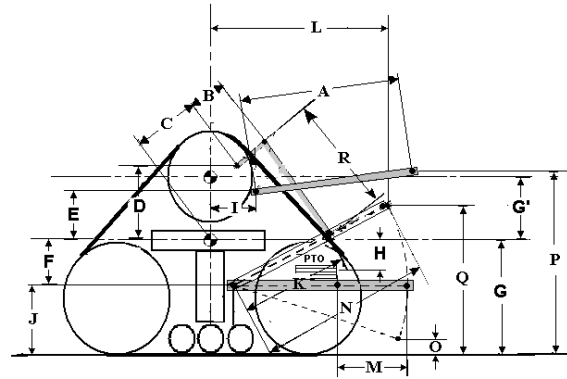

**NEW HOLLAND T8.435 SMARTTRAX DIESEL**