

University of Nebraska - Lincoln

DigitalCommons@University of Nebraska - Lincoln

Nebraska Tractor Tests

Tractor Test and Power Museum, The Lester F.
Larsen

2017

Test 2180: CLAAS Axion 820

Nebraska Tractor Test Lab

University of Nebraska-Lincoln, tractortestlab@unl.edu

Follow this and additional works at: <https://digitalcommons.unl.edu/tractormuseumlit>



Part of the [Energy Systems Commons](#), [History of Science, Technology, and Medicine Commons](#), [Other Mechanical Engineering Commons](#), [Physical Sciences and Mathematics Commons](#), [Science and Mathematics Education Commons](#), and the [United States History Commons](#)

Nebraska Tractor Test Lab, "Test 2180: CLAAS Axion 820" (2017). *Nebraska Tractor Tests*. 2585.
<https://digitalcommons.unl.edu/tractormuseumlit/2585>

This Article is brought to you for free and open access by the Tractor Test and Power Museum, The Lester F. Larsen at DigitalCommons@University of Nebraska - Lincoln. It has been accepted for inclusion in Nebraska Tractor Tests by an authorized administrator of DigitalCommons@University of Nebraska - Lincoln.

NEBRASKA OECD TRACTOR TEST 2180—SUMMARY 1104

CLAAS AXION 820 DIESEL

CONTINUOUSLY VARIABLE TRANSMISSION

POWER TAKE-OFF PERFORMANCE

Power HP (kW)	Crank shaft speed rpm	Diesel Consumption		D.E.F. Consumption		Mean Atmospheric Conditions
		Gal/hr (l/h)	lb/hp.hr (kg/kW.h)	Hp.hr/gal (kW.h/l)	Gal/hr (l/h)	
MAXIMUM POWER AND FUEL CONSUMPTION						
Rated Engine Speed—(PTO speed—1114 rpm)						
199.49 (148.76)	2150	11.24 (42.53)	0.394 (0.240)	17.75 (3.50)	0.69 (2.61)	
Standard Power Take-off Speed (1000 rpm)						
212.48 (158.45)	1930	11.50 (43.32)	0.378 (0.230)	18.48 (3.64)	0.69 (2.61)	
Maximum Power (1 hour)						
215.43 (160.64)	1801	11.40 (43.16)	0.370 (0.225)	18.90 (3.72)	0.71 (2.70)	

VARYING POWER AND FUEL CONSUMPTION

199.49 (148.76)	2150	11.24 (42.53)	0.394 (0.240)	17.75 (3.50)	0.69 (2.61)	Air temperature
172.14 (128.37)	2183	9.91 (37.50)	0.402 (0.245)	17.38 (3.42)	0.64 (2.42)	77°F (25°C)
129.40 (96.50)	2187	7.85 (24.90)	0.424 (0.258)	16.49 (3.25)	0.50 (1.90)	Relative humidity
86.46 (64.48)	2190	5.90 (22.33)	0.477 (0.290)	14.66 (2.89)	0.39 (1.46)	52%
43.44 (32.39)	2193	4.06 (15.37)	0.654 (0.398)	10.70 (2.11)	0.25 (0.95)	Barometer
1.93 (1.44)	2196	2.34 (8.87)	8.500 (5.170)	0.82 (0.16)	0.14 (0.53)	28.77" Hg (97.44 kPa)

Maximum torque - 704 lb.-ft. (955 Nm) at 1400 rpm

Maximum torque rise - 44.6%

Torque rise at 1720 engine rpm - 33%

Power increase at 1801 engine rpm - 8.0%

DRAWBAR PERFORMANCE

UNBALLASTED - FRONT DRIVE ENGAGED FUEL CONSUMPTION CHARACTERISTICS

Power Hp (kW)	Drawbar pull lbs (kN)	Speed mph (km/h)	Crank- shaft speed rpm	Slip %	Fuel Consumption lb/hp.hr (kg/kW.h)	D.E.F. Consumption lb/hp.hr (kg/kW.h)	Temp. °F(°C) cool- ing med bulb	Air dry bulb	Barom. inch Hg (kPa)	
Power at Rated Engine Speed—5.6 mph (9.0 km/h)-Manual mode										
168.63 (125.75)	11362 (50.54)	5.57 (8.96)	2149	3.5	0.462 (0.281)	15.12 (2.98)	0.038 (0.023)	186 (86)	70 (21)	28.59 (96.82)
75% of Pull at Rated Engine Speed—5.6 mph (9.0 km/h)-Manual mode										
126.82 (94.57)	8528 (37.93)	5.58 (8.98)	2173	2.8	0.481 (0.293)	14.53 (2.86)	0.042 (0.026)	207 (97)	85 (29)	28.46 (96.38)
50% of Pull at Rated Engine Speed—5.6 mph (9.0 km/h)-Manual mode										
85.32 (63.62)	5672 (25.23)	5.64 (9.08)	2179	2.0	0.544 (0.331)	12.86 (2.53)	0.048 (0.029)	203 (95)	85 (30)	28.46 (96.38)
75% of Pull at Reduced Engine Speed—Auto mode										
126.68 (94.47)	8480 (37.72)	5.61 (9.02)	1291	2.8	0.440 (0.268)	15.88 (3.13)	0.043 (0.026)	212 (100)	88 (31)	28.46 (96.38)
50% of Pull at Reduced Engine Speed—Auto mode										
85.73 (63.93)	5683 (25.28)	5.66 (9.10)	1294	2.0	0.466 (0.283)	15.01 (2.96)	0.046 (0.028)	210 (99)	88 (31)	28.45 (96.34)

Location of tests: Nebraska Tractor Test Laboratory, University of Nebraska, Lincoln, Nebraska 68583-0832

Dates of tests: September 12 to 29, 2017

Manufacturer: Claas Tractor SAS, 7, rue Dewoitine - BP 92, 78141 Velizy-Villacoublay, Cedex, France

CONSUMABLE Fluids, OIL and TIME: Fuel No. 2 Diesel **Specific gravity converted to 60°/60°F (15°/15°C)** 0.8400 **Fuel weight** 6.994 lbs/gal (0.838 kg/l) **Diesel Exhaust Fluid (DEF)** 32% aqueous urea solution **DEF weight** 9.071 lbs/gal (1.087 kg/l) **Oil SAE 10W40 API service classification** CJ-4 **Transmission lubricant** Claas Agrishift GA12 fluid **Hydraulic lubricant** Claas Agrishift GA12 fluid **Front axle lubricant** Claas Agrishift BLS 90 API GL-5 **Total time engine was operated:** 28.0 hours

ENGINE: Make F.P.T. Diesel **Type** six cylinder vertical with turbocharger, air to air intercooler and D.E.F. (diesel exhaust fluid) exhaust treatment. **Serial No.** *001483732* **Crankshaft** lengthwise **Rated engine speed** 2150 **Bore and stroke** 4.094" x 5.197" (104.0 mm x 132.0 mm) **Compression ratio** 17.5 to 1 **Displacement** 410 cu in (6728 ml) **Starting system** 12 volt **Lubrication** pressure **Air cleaner** two paper elements and aspirator **Oil filter** one full flow cartridge **Oil cooler** engine coolant heat exchanger for crankcase oil, radiator for hydraulic and transmission oil **Fuel filter** two paper elements **Fuel cooler** radiator for pump return fuel **Exhaust** DOC (diesel oxidation catalyst) and SCR (selective catalyst reduction) integrated within a vertical muffler **Cooling medium temperature control** thermostat and variable speed fan

ENGINE OPERATING PARAMETERS: Fuel rate: 77.9 - 81.3 lb/h (35.3 - 36.9 kg/h) **High idle:** 2180 - 2220 rpm **Turbo boost:** nominal 18.9 - 21.8 psi (130 - 150 kPa) as measured 20.3 psi (140 kPa)

CHASSIS: Type front wheel assist with duals **Serial No.** *A4102764* **Tread width** rear 61.4" (1560 mm) to 124.0" (3150 mm) front 61.0" (1550 mm) to 88.6" (2250 mm) **Wheelbase** 117.3" (2980 mm) **Hydraulic control system** direct engine drive **Transmission** infinitely variable with four mechanical ranges and automatic shifting between ranges. **Nominal travel speeds mph (km/h)** forward - 0 - 30.0 mph (0 - 50 km/h), reverse - 0 - 30.0 mph (0 - 50 km/h) **Clutch** multiple wet disc electrohydraulically operated by foot pedal **Brakes** wet disc hydraulically operated by two foot pedals that can be locked together **Steering** hydrostatic **Power take-off** 540 rpm at 1890 engine rpm or 1000 rpm at 1930 or 1594 engine rpm **Unladen tractor mass** 21635 lb (9813 kg)

DRAWBAR PERFORMANCE
UNBALLASTED - FRONT DRIVE ENGAGED

MANUAL MODE - 2150 ENGINE RPM
DRAWBAR POWER AT SELECTED TRAVEL SPEED SETTINGS

Power Hp (kW)	Drawbar pull lbs (kN)	Speed mph (km/h)	Crank- shaft speed rpm	Slip %	Fuel Consumption lb/hp.hr (kg/kW.h)	Hp.hr/gal (kW.h/l)	D.E.F. Consumption lb/hp.hr (kg/kW.h)	Temp. °F(°C) cool- ing med	Air dry bulb	Barom. inch Hg (kPa)
2.5 mph (4.0 km/h)										
126.23 (94.13)	20171 (89.72)	2.35 (3.78)	2168	14.3	0.546 (0.332)	12.81 (2.52)	0.046 (0.028)	193 (89)	73 (23)	28.47 (96.41)
3.1 mph (5.0 km/h)										
140.46 (104.74)	18078 (80.41)	2.91 (4.68)	2150	7.0	0.497 (0.302)	14.09 (2.77)	0.042 (0.025)	192 (89)	74 (23)	28.47 (96.41)
3.7 mph (6.0 km/h)										
143.51 (107.02)	15038 (66.89)	3.58 (5.76)	2150	5.0	0.485 (0.295)	14.43 (2.84)	0.041 (0.025)	193 (89)	75 (24)	28.48 (96.44)
4.2 mph (6.8 km/h)										
149.24 (111.28)	13685 (60.87)	4.09 (6.58)	2150	4.5	0.484 (0.295)	14.44 (2.84)	0.041 (0.025)	193 (89)	77 (25)	28.61 (96.88)
4.7 mph (7.5 km/h)										
161.78 (120.64)	13355 (59.41)	4.54 (7.31)	2149	4.2	0.485 (0.295)	14.42 (2.84)	0.039 (0.024)	186 (86)	64 (18)	28.60 (96.85)
5.1 mph (8.2 km/h)										
164.70 (122.81)	12349 (54.93)	5.00 (8.05)	2149	3.9	0.475 (0.289)	14.74 (2.90)	0.039 (0.024)	186 (86)	70 (21)	28.59 (96.82)
5.6 mph (9.0 km/h)										
168.63 (125.75)	11362 (50.54)	5.57 (8.96)	2149	3.5	0.462 (0.281)	15.12 (2.98)	0.038 (0.023)	186 (86)	70 (21)	28.59 (96.82)
6.2 mph (10.0 km/h)										
171.27 (127.71)	10298 (45.81)	6.24 (10.04)	2149	3.2	0.456 (0.277)	15.35 (3.02)	0.038 (0.023)	186 (85)	72 (22)	28.59 (96.82)
6.8 mph (11.0 km/h)										
171.37 (127.79)	9606 (42.73)	6.69 (10.77)	2150	3.1	0.456 (0.277)	15.35 (3.02)	0.039 (0.024)	192 (89)	80 (27)	28.56 (96.72)
7.5 mph (12.0 km/h)										
171.34 (127.77)	8684 (38.63)	7.40 (11.91)	2150	2.8	0.455 (0.277)	15.37 (3.03)	0.039 (0.024)	191 (88)	81 (27)	28.56 (96.72)
8.2 mph (13.2 km/h)										
169.91 (126.70)	7889 (35.09)	8.08 (13.00)	2149	2.5	0.458 (0.279)	15.27 (3.01)	0.040 (0.024)	192 (89)	82 (28)	28.56 (96.72)

REPAIRS AND ADJUSTMENTS: No repairs or adjustments.

NOTE: This engine on this model derates at travel speeds below 4.3 mph (7.0 km/h).

REMARKS: All test results were determined from observed data obtained in accordance with official OECD, SAE and Nebraska test procedures. This tractor fell 1% short of meeting the manufacturer's torque rise claim of 45%. This tractor exceeded the 74 dB(A) sound power claim, with front drive engaged, by 99.5% (3.0 dB(A)) at 2190 engine rpm and 28.8% (1.1 dB(A)) at 1110 engine rpm. The manufacturer's hydraulic pump flow claim of 40 GPM was not verified. The performance results on this summary were taken from a test conducted under the OECD Code 2 test procedure.

We, the undersigned, certify that this is a true and correct report of official Tractor Test No. **2180**, Nebraska Summary 1104, December 11, 2017.

Roger M. Hoy
Director

M.F. Kocher
S.K. Pitla
J.D. Luck
Board of Tractor Test Engineers

TRACTOR SOUND LEVEL WITH CAB	Front Wheel Drive	
	Engaged dB(A)	Disengaged dB(A)
At no load at 4.6 mph (7.5 km/h) engine speed - 2190 rpm	77.0	70.0
At no load at 4.6 mph (7.5 km/h) engine speed - 1110 rpm	75.1	64.2
Bystander		80.4

Horizontal distance of drawbar hitch point behind rear wheel axis - 38.5" (978 mm)

TIRES AND WEIGHT

Rear Tires - No., size, ply & psi (kPa)
Front Tires - No., size, ply & psi (kPa)
Height of Drawbar
Static Weight with operator - Rear
- Front
- Total

Tested Without Ballast

Four 480/80R46;***;12(85)
Two 380/85R34;***;21(145)
21.0 in (535 mm)
13610 lb (6173 kg)
8200 lb (3719 kg)
21810 lb (9892 kg)

DRAWBAR PERFORMANCE
UNBALLASTED - FRONT DRIVE ENGAGED

AUTOMATIC MODE(Loads based on 2150 engine rpm manual mode performance runs)

Power Hp (kW)	Drawbar pull lbs (kN)	Speed mph (km/h)	Crank- shaft speed rpm	Slip %	Fuel Consumption		D.E.F. Consumption	Temp. ^o F(°C) cool- ing med	Air dry bulb	Barom. inch Hg (kPa)
					lb/hp.hr (kg/kW.h)	Hp.hr/gal (kW.h/l)	lb/hp.hr (kg/kW.h)			
3.1 mph (5.0 km/h)										
138.53 (103.30)	17924 (79.73)	2.91 (4.68)	1544	7.4	0.468 (0.284)	14.96 (2.95)	0.040 (0.024)	214 (101)	84 (29)	28.50 (96.51)
3.7 mph (6.0 km/h)										
143.15 (106.74)	14870 (66.15)	3.61 (5.81)	1485	5.2	0.442 (0.269)	15.82 (3.12)	0.037 (0.023)	214 (101)	83 (29)	28.50 (96.51)
4.1 mph (6.6 km/h)										
148.29 (110.58)	13646 (60.70)	4.08 (6.56)	1483	4.8	0.434 (0.264)	16.10 (3.17)	0.037 (0.023)	214 (101)	86 (30)	28.50 (96.51)
4.7 mph (7.5 km/h)										
161.71 (120.59)	13399 (59.60)	4.53 (7.28)	1463	4.7	0.429 (0.261)	16.32 (3.21)	0.037 (0.023)	216 (102)	87 (31)	28.50 (96.51)
5.1 mph (8.2 km/h)										
162.96 (121.52)	12470 (55.47)	4.91 (7.89)	1463	4.3	0.428 (0.261)	16.33 (3.22)	0.037 (0.022)	216 (102)	88 (31)	28.48 (96.44)
5.6 mph (9.0 km/h)										
168.96 (125.99)	11624 (51.71)	5.46 (8.78)	1537	3.9	0.427 (0.260)	16.37 (3.22)	0.036 (0.022)	216 (102)	89 (31)	28.48 (96.44)
6.3 mph (10.2 km/h)										
168.82 (125.89)	10223 (45.47)	6.20 (9.97)	1556	3.4	0.431 (0.262)	16.23 (3.20)	0.037 (0.023)	216 (102)	91 (33)	28.48 (96.44)
6.8 mph (11.0 km/h)										
171.07 (127.57)	9500 (42.26)	6.76 (10.87)	1648	3.2	0.429 (0.261)	16.31 (3.21)	0.038 (0.023)	212 (100)	92 (33)	28.48 (96.44)
7.5 mph (12.0 km/h)										
168.16 (125.39)	8733 (38.85)	7.23 (11.63)	1586	3.0	0.439 (0.267)	15.94 (3.14)	0.036 (0.022)	215 (101)	93 (34)	28.46 (96.38)
8.2 mph (13.2 km/h)										
169.11 (126.10)	7949 (35.36)	7.98 (12.84)	1631	2.8	0.441 (0.268)	15.85 (3.12)	0.038 (0.023)	214 (101)	91 (33)	28.46 (96.38)

DRAWBAR PERFORMANCE
UNBALLASTED - FRONT DRIVE ENGAGED

MANUAL MODE - 1800 ENGINE RPM
DRAWBAR POWER AT SELECTED TRAVEL SPEED SETTINGS

Power Hp (kW)	Drawbar pull lbs (kN)	Speed mph (km/h)	Crank- shaft speed rpm	Slip %	Fuel Consumption lb/hp.hr (kg/kW.h)	Hp.hr/gal (kW.h/l)	D.E.F. Consumption lb/hp.hr (kg/kW.h)	Temp.°F(°C) cool- ing med	Air dry bulb	Barom. inch Hg (kPa)
2.5 mph (4.0 km/h)										
126.20 (94.10)	20207 (89.89)	2.35 (3.77)	2167	14.5	0.546 (0.332)	12.81 (2.52)	0.046 (0.028)	193 (89)	73 (23)	28.47 (96.41)
3.1 mph (5.0 km/h)										
143.42 (106.94)	19093 (84.93)	2.82 (4.54)	2107	8.1	0.499 (0.304)	14.01 (2.76)	0.042 (0.025)	192 (89)	74 (24)	28.47 (96.41)
3.7 mph (6.0 km/h)										
151.33 (112.85)	16412 (73.00)	3.46 (5.57)	2061	5.4	0.481 (0.292)	14.55 (2.87)	0.037 (0.023)	192 (89)	73 (23)	28.50 (96.51)
4.2 mph (6.8 km/h)										
162.98 (121.53)	15300 (68.06)	4.00 (6.43)	2045	5.0	0.475 (0.289)	14.72 (2.90)	0.037 (0.023)	189 (87)	71 (22)	28.50 (96.51)
4.7 mph (7.5 km/h)										
169.13 (126.12)	14755 (65.63)	4.30 (6.92)	2036	4.8	0.476 (0.290)	14.68 (2.89)	0.037 (0.023)	192 (89)	74 (24)	28.50 (96.51)
5.1 mph (8.2 km/h)										
173.43 (129.32)	14038 (62.44)	4.64 (7.46)	2024	4.6	0.463 (0.281)	15.12 (2.98)	0.036 (0.022)	189 (87)	75 (24)	28.50 (96.51)
5.6 mph (9.0 km/h)										
178.83 (133.35)	13651 (60.72)	4.92 (7.91)	1933	4.4	0.446 (0.272)	15.67 (3.09)	0.034 (0.021)	189 (87)	74 (23)	28.50 (96.51)
6.2 mph (10.0 km/h)										
183.03 (136.48)	12932 (57.52)	5.31 (8.54)	1875	4.2	0.433 (0.264)	16.14 (3.18)	0.035 (0.021)	189 (87)	75 (24)	28.49 (96.48)
6.8 mph (11.0 km/h)										
185.23 (138.12)	12542 (55.79)	5.54 (8.92)	1800	4.1	0.427 (0.260)	16.37 (3.23)	0.033 (0.020)	188 (87)	77 (25)	28.49 (96.48)
7.5 mph (12.0 km/h)										
184.50 (137.58)	11347 (50.47)	6.10 (9.82)	1800	3.7	0.428 (0.260)	16.35 (3.22)	0.034 (0.021)	189 (87)	79 (26)	28.49 (96.48)
8.2 mph (13.2 km/h)										
184.01 (137.21)	10265 (45.66)	6.72 (10.81)	1800	3.4	0.429 (0.261)	16.29 (3.21)	0.034 (0.021)	190 (88)	80 (27)	28.49 (96.48)
8.9 mph (14.4 km/h)										
181.06 (135.02)	9161 (40.75)	7.41 (11.93)	1800	3.1	0.435 (0.265)	16.06 (3.16)	0.034 (0.021)	191 (88)	81 (27)	28.49 (96.48)
9.9 mph (16.0 km/h)										
175.11 (130.58)	7740 (34.43)	8.49 (13.66)	1801	2.6	0.451 (0.275)	15.49 (3.05)	0.036 (0.022)	193 (89)	81 (27)	28.50 (96.51)

Shiftable PTO Performance

Economy mode

1000 PTO rpm @ 1594 engine rpm

Power HP (kW)	Crank shaft speed rpm	Diesel Consumption		D.E.F. Consumption	
		Gal/hr (l/h)	lb/hp.hr (kg/kW.h)	Hp.hr/gal (kW.h/l)	Gal/hr (l/h)
203.75 (151.94)	1595	10.75 (40.68)	0.369 (0.224)	18.96 (3.73)	0.71 (2.67)
152.62 (113.81)	1591	8.12 (30.73)	0.372 (0.226)	18.80 (3.70)	0.56 (2.12)
101.66 (75.81)	1591	5.72 (21.66)	0.394 (0.239)	17.77 (3.50)	0.39 (1.47)
50.99 (38.02)	1591	3.46 (13.11)	0.475 (0.289)	14.72 (2.90)	0.23 (0.88)
1.62 (1.21)	1591	1.38 (5.24)	5.991 (3.644)	1.17 (0.23)	0.12 (0.46)

Normal mode

1000 PTO rpm @ 1930 engine rpm

Power HP (kW)	Crank shaft speed rpm	Diesel Consumption		D.E.F. Consumption	
		Gal/hr (l/h)	lb/hp.hr (kg/kW.h)	Hp.hr/gal (kW.h/l)	Gal/hr (l/h)
204.05 (152.16)	1934	11.10 (42.00)	0.380 (0.231)	18.39 (3.62)	0.70 (2.65)
153.22 (114.26)	1934	8.59 (32.52)	0.392 (0.239)	17.83 (3.51)	0.55 (2.07)
102.09 (76.13)	1934	6.19 (23.42)	0.424 (0.258)	16.50 (3.25)	0.41 (1.56)
51.16 (38.15)	1934	3.94 (14.91)	0.539 (0.328)	12.99 (2.56)	0.26 (1.00)
1.58 (1.18)	1934	1.88 (7.11)	8.290 (5.043)	0.84 (0.17)	0.14 (0.53)

HYDRAULIC PERFORMANCE

CATEGORY: III

Quick Attach: Yes

OECD Static test

Maximum force exerted through whole range:	17408 lbs (77.4 kN)
	three outlet sets combined
i) Sustained pressure at compensator cutoff:	2746 psi (189 bar)
ii) Pump delivery rate at minimum pressure and rated engine speed:	39.3 GPM (148.8 l/min)
iii) Pump delivery rate at maximum hydraulic power:	36.7 GPM (138.8 l/min)
Delivery pressure:	2498 psi (172 bar)
Power:	53.4 HP (39.9 kW)
	single outlet set
i) Sustained pressure at compensator cutoff:	2728 psi (188 bar)
ii) Pump delivery rate at minimum pressure and rated engine speed:	30.9 GPM (116.9 l/min)
iii) Pump delivery rate at maximum hydraulic power:	30.1 GPM (114.1 l/min)
Delivery pressure:	2198 psi (152 bar)
Power:	38.7 HP (28.8 kW)

HITCH DIMENSIONS AS TESTED—NO LOAD

	inch	mm
A	32.7	830
B	15.7	400
C	20.7	525
D	19.1	485
E	11.6	295
F	12.2	310
G	36.4	925
H	2.9	74
I	16.9	430
J	24.2	615
K	25.4	646
L	51.1	1298
*L'	56.6	1438
M	27.6	701
N	40.9	1040
O	9.1	230
P	43.1	1095
Q	39.6	1005
R	37.6	955

*L' to Quick Attach ends

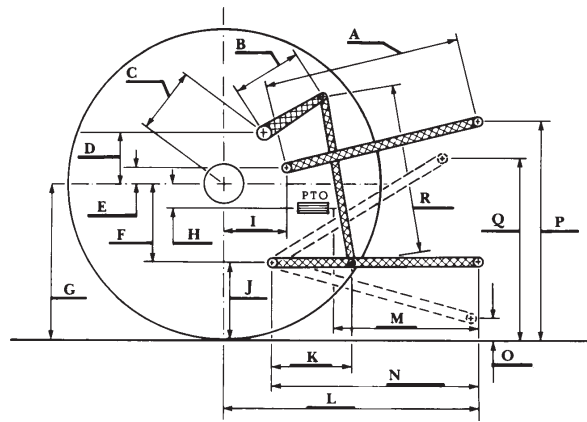

NTTL.(2017). Nebraska OECD tractor test 2180 for Claas Axion 820 Diesel.

Lincoln, NE:Nebraska Tractor Test Laboratory. Retrieved from <http://tractortestlab.unl.edu>



CLAAS AXION 820 DIESEL