

University of Nebraska - Lincoln

DigitalCommons@University of Nebraska - Lincoln

---

Nebraska Tractor Tests

Tractor Test and Power Museum, The Lester F.  
Larsen

---

2017

## Test 2186: Case IH Steiger 470 QuadTrac

Nebraska Tractor Test Lab

University of Nebraska-Lincoln, tractortestlab@unl.edu

Follow this and additional works at: <https://digitalcommons.unl.edu/tractormuseumlit>



Part of the [Energy Systems Commons](#), [History of Science, Technology, and Medicine Commons](#), [Other Mechanical Engineering Commons](#), [Physical Sciences and Mathematics Commons](#), [Science and Mathematics Education Commons](#), and the [United States History Commons](#)

---

Nebraska Tractor Test Lab, "Test 2186: Case IH Steiger 470 QuadTrac" (2017). *Nebraska Tractor Tests*. 2654.

<https://digitalcommons.unl.edu/tractormuseumlit/2654>

This Article is brought to you for free and open access by the Tractor Test and Power Museum, The Lester F. Larsen at DigitalCommons@University of Nebraska - Lincoln. It has been accepted for inclusion in Nebraska Tractor Tests by an authorized administrator of DigitalCommons@University of Nebraska - Lincoln.

# NEBRASKA OECD TRACTOR TEST 2186 - SUMMARY 1117

## CASE IH STEIGER 470 QUADTRAC DIESEL

### 16 SPEED

#### POWER TAKE-OFF PERFORMANCE

Power HP (kW)	Crank shaft speed rpm	Diesel Consumption		D.E.F. Consumption		Mean Atmospheric Conditions
		Gal/hr (l/h)	lb/hp.hr (kg/kW.h)	Hp.hr/gal (kW.h/l)	Gal/hr (l/h)	
<b>MAXIMUM POWER AND FUEL CONSUMPTION</b>						
<b>Rated Engine Speed—(PTO speed—1160 rpm)</b>						
422.14 (314.79)	2101	23.73 (89.85)	0.393 (0.239)	17.79 (3.50)	1.92 (7.26)	
<b>Maximum Power (1 hour)</b>						
477.78 (356.28)	1900	25.07 (94.88)	0.367 (0.223)	19.06 (3.75)	2.14 (8.10)	
<b>Standard Power Take-off Speed (1000 rpm)</b>						
472.19 (352.11)	1811	24.37 (92.23)	0.361 (0.220)	19.38 (3.82)	2.06 (7.78)	

#### VARYING POWER AND FUEL CONSUMPTION

422.14 (314.79)	2101	23.73 (89.85)	0.393 (0.239)	17.79 (3.50)	1.92 (7.26)	Air temperature
366.74 (273.48)	2148	21.27 (80.53)	0.406 (0.247)	17.24 (3.40)	1.60 (6.05)	74°F (23°C)
276.40 (206.11)	2156	16.98 (64.28)	0.430 (0.261)	16.28 (3.21)	1.19 (4.50)	Relative humidity
184.90 (137.88)	2167	12.88 (48.76)	0.487 (0.296)	14.35 (2.83)	0.87 (3.29)	43%
92.91 (69.28)	2178	8.95 (33.87)	0.674 (0.410)	10.38 (2.05)	0.59 (2.24)	Barometer
2.38 (1.78)	2187	5.10 (19.32)	14.967 (9.104)	0.47 (0.09)	0.22 (0.83)	28.72" Hg (97.27 kPa)

Maximum torque - 1561 lb-ft (2117 Nm) at 1400 rpm

Maximum torque rise - 47.9%

Torque rise at 1681 engine rpm - 37%

Power increase at 1900 engine rpm - 13.2%

#### DRAWBAR PERFORMANCE FUEL CONSUMPTION CHARACTERISTICS

Power Hp (kW)	Drawbar pull lbs (kN)	Speed mph (km/h)	Crank- shaft speed rpm	Slip %	Fuel Consumption lb/hp.hr (kg/kW.h)	D.E.F. Consumption Hp.hr/gal (kW.h/l)	Temp. °F (°C)	Barom. inch Hg (kPa)
							cool- ing med	Air dry bulb
<b>Power at Rated Engine Speed—4th Gear</b>								
372.34 (277.65)	29218 (129.97)	4.78 (7.69)	2099	2.0	0.446 (0.271)	15.70 (3.09)	0.041 (0.025)	194 (90)
55	28.79 (97.49)							
<b>75% of Pull at Rated Engine Speed—4th Gear</b>								
288.12 (214.85)	21873 (97.29)	4.94 (7.95)	2151	1.2	0.472 (0.287)	14.81 (2.92)	0.040 (0.025)	187 (86)
57	28.79 (97.49)							
<b>50% of Pull at Rated Engine Speed—4th Gear</b>								
194.37 (144.94)	14596 (64.93)	4.99 (8.03)	2163	0.6	0.531 (0.323)	13.17 (2.59)	0.045 (0.027)	183 (84)
57	28.79 (97.49)							
<b>75% of Pull at Reduced Engine Speed—8th Gear</b>								
287.95 (214.72)	21892 (97.38)	4.93 (7.93)	1413	1.2	0.398 (0.242)	17.57 (3.46)	0.041 (0.025)	182 (83)
57	28.80 (97.53)							
<b>50% of Pull at Reduced Engine Speed—8th Gear</b>								
194.03 (144.69)	14607 (64.97)	4.98 (8.01)	1420	0.6	0.438 (0.266)	15.97 (3.15)	0.039 (0.024)	180 (82)
57	28.80 (97.53)							

**Location of tests:** Nebraska Tractor Test Laboratory, University of Nebraska, Lincoln Nebraska 68583-0832

**Dates of tests:** October 12 - 17, 2017

**Manufacturer:** CNH Industrial America LLC, 700 State Street Racine, Wi. 53404 USA.

**CONSUMABLE Fluids, OIL and TIME: Fuel** No. 2 Diesel **Specific gravity converted to 60°/60°F (15°/15°C)** 0.8400 **Fuel weight** 6.994 lbs/gal (0.838 kg/l) **Diesel Exhaust Fluid (DEF)** 32% aqueous urea solution **DEF weight** 9.071 lbs/gal (1.087 kg/l) **Oil** SAE 15W40 **API service classification** CJ-4 **Transmission lubricant** Akcela Hy-Tran Ultraction fluid **Hydraulic and axle lubricant** Akcela Hy-Tran Ultraction fluid **Total time engine was operated:** 15.5 hours

**ENGINE: Make** F.P.T. Diesel **Type** six cylinder vertical with turbocharger, air to air intercooler and D.E.F. (diesel exhaust fluid) exhaust treatment **Serial No.** 00000288866 **Crankshaft** lengthwise **Rated engine speed** 2100 **Bore and stroke** 5.315" x 5.906" (135.0 mm x 150.0 mm) **Compression ratio** 15.5 to 1 **Displacement** 786 cu in (12880 ml) **Starting system** 24 volt **Lubrication** pressure **Air cleaner** two paper elements and aspirator **Oil filter** one full flow cartridge **Oil cooler** engine coolant heat exchanger for crankcase oil, separate radiators for hydraulic and transmission oil **Fuel filter** two paper elements **Fuel cooler** radiator for pump return fuel **Exhaust** DOC (diesel oxidation catalyst) and SCR (selective catalyst reduction) within a vertical muffler **Cooling medium temperature control** thermostat and variable speed fan

**ENGINE OPERATING PARAMETERS: Fuel rate:** 160.9 - 170.6 lb/h (73.0 - 77.4 kg/h) **High idle:** 2175 - 2225 rpm **Turbo boost:** nominal 22.5 - 25.4 psi (155 - 175 kPa) as measured 23.9 psi (165 kPa)

**CHASSIS: Type** 4WD with rubber tracks **Serial No.** \*ZHF311627\* **Track width** rear 88.0" (2235 mm) front 88.0" (2235 mm) **Trackbase** 154.0" (3912 mm) **Length of track on ground** 29.4" (748 mm) **Hydraulic control system** direct engine drive **Transmission** selective gear fixed ratio with full range operator controlled powershift **Nominal travel speeds mph (km/h)** first 2.77 (4.45) second 3.33 (5.36) third 4.03 (6.48) fourth 4.85 (7.80) fifth 5.57 (8.96) sixth 6.11 (9.84) seventh 6.70 (10.79) eighth 7.37 (11.86) ninth 8.10 (13.03) tenth 8.90 (14.32) eleventh 9.76 (15.70) twelfth 10.72 (17.25) thirteenth 12.31 (19.81) fourteenth 14.83 (23.86) fifteenth 17.90 (28.81) sixteenth 21.01 (33.81) reverse 4.21 (6.77), 9.30 (14.97)

**DRAWBAR PERFORMANCE AT 2100 ENGINE RPM  
MAXIMUM POWER IN SELECTED GEARS**

Power Hp (kW)	Drawbar pull lbs (kN)	Speed mph (km/h)	Crank- shaft speed rpm	Slip %	Fuel Consumption lb/hp.hr (kg/kW.h)	Hp.hr/gal (kW.h/l)	D.E.F. Consumption lb/hp.hr (kg/kW.h)	Temp. °F (°C) cool- ing med	Air dry bulb	Barom. inch Hg (kPa)
1st Gear										
342.73 (255.57)	50899 (226.41)	2.53 (4.06)	2098	9.3	0.477 (0.290)	14.67 (2.89)	0.047 (0.028)	188 (86)	54 (12)	29.08 (98.46)
2nd Gear										
364.60 (271.88)	43034 (191.42)	3.18 (5.12)	2099	5.3	0.455 (0.277)	15.36 (3.03)	0.044 (0.027)	194 (90)	59 (15)	29.06 (98.41)
3rd Gear										
373.20 (278.30)	35754 (159.04)	3.91 (6.29)	2100	3.4	0.443 (0.270)	15.78 (3.11)	0.045 (0.027)	200 (93)	62 (27)	29.05 (98.37)
4th Gear										
372.34 (277.65)	29218 (129.97)	4.78 (7.69)	2099	2.0	0.446 (0.271)	15.70 (3.09)	0.041 (0.025)	194 (90)	55 (13)	28.79 (97.49)
5th Gear										
374.62 (279.35)	25475 (113.32)	5.51 (8.87)	2100	1.6	0.444 (0.270)	15.75 (3.10)	0.041 (0.025)	198 (92)	55 (13)	28.79 (97.49)
6th Gear										
372.93 (278.09)	23015 (102.38)	6.08 (9.78)	2100	1.3	0.446 (0.271)	15.69 (3.09)	0.042 (0.026)	196 (91)	55 (13)	28.81 (97.56)
7th Gear										
370.68 (276.41)	20821 (92.61)	6.68 (10.74)	2100	1.1	0.448 (0.272)	15.63 (3.08)	0.042 (0.026)	200 (93)	55 (13)	28.80 (97.53)
8th Gear										
368.05 (274.45)	18785 (83.56)	7.35 (11.83)	2101	0.9	0.453 (0.276)	15.44 (3.04)	0.043 (0.026)	195 (90)	56 (13)	28.79 (97.49)
9th Gear										
366.87 (273.57)	17019 (75.70)	8.09 (13.01)	2100	0.8	0.451 (0.275)	15.50 (3.05)	0.042 (0.026)	200 (93)	56 (13)	28.79 (97.49)

**Clutch** multiple wet disc electro-hydraulically operated by foot pedal **Brakes** single wet disc hydraulically actuated by foot pedal **Steering** hydrostatic and articulated **Power take-off** 1000 rpm at 1811 engine rpm **Unladen tractor mass** 57470 lb (26068 kg)

**REPAIRS AND ADJUSTMENTS:** No repairs or adjustments.

**NOTE 1:** This tractor has a driveline protection system that limits the maximum engine torque in gears 1 through 3.

**NOTE 2:** The performance figures on this report are the result of replacing the electronic engine control module of the Case IH 500 Quadtrac with the Case IH 470 Quadtrac module.

**REMARKS:** All test results were determined from observed data obtained in accordance with official OECD, SAE and Nebraska test procedures. The performance figures on this Summary were taken from a test conducted under the OECD Code 2 test procedure.

We, the undersigned, certify that this is a true and correct report of official Tractor Test No. **2186**, Nebraska Summary 1117, December 11, 2017.

Roger M. Hoy  
Director

M.F. Kocher  
J.D. Luck  
S.K. Pitla  
Board of Tractor Test Engineers

TRACTOR SOUND LEVEL WITH CAB	dB(A)
At no load in 4th gear	74.3
Bystander in 15th Gear	88.6

Horizontal distances of drawbar hitch point behind rear wheel axis - 49.2"(1250 mm), 55.1"(1400 mm)

**TRACKS AND WEIGHT**

<b>Rear tracks - no &amp; size</b>	<b>Tested Without Ballast</b>
<b>Front tracks - no &amp; size</b>	2 x 30.0 in (762 mm)
<b>Height of drawbar</b>	2 x 30.0 in (762 mm)
<b>Static weight with operator- Rear</b>	20.5 in (520 mm)
<b>- Front</b>	23155 lb (10503 kg)
<b>- Total</b>	34490 lb (15644 kg)
	57645 lb (26147 kg)

**DRAWBAR PERFORMANCE AT 1900 ENGINE RPM  
MAXIMUM POWER IN SELECTED GEARS**

Power Hp (kW)	Drawbar pull lbs (kN)	Speed mph (km/h)	Crank- shaft speed rpm	Slip %	Fuel Consumption lb/hp.hr (kg/kW.h)	Hp.hr/gal (kW.h/l)	D.E.F. Consumption lb/hp.hr (kg/kW.h)	Temp.°F (°C) cool- ing med	Air dry bulb	Barom. inch Hg (kPa)
1st Gear										
330.82 (246.69)	51680 (229.88)	2.40 (3.86)	2003	9.6	0.465 (0.283)	15.03 (2.96)	0.049 (0.030)	186 (86)	57 (14)	29.07 (98.44)
2nd Gear										
381.24 (284.29)	50561 (224.90)	2.83 (4.55)	1928	8.2	0.442 (0.269)	15.81 (3.11)	0.054 (0.033)	197 (92)	61 (16)	29.05 (98.37)
3rd Gear										
411.03 (306.50)	44540 (198.12)	3.46 (5.57)	1900	5.6	0.426 (0.259)	16.41 (3.23)	0.050 (0.030)	203 (95)	64 (18)	29.04 (98.34)
4th Gear										
419.75 (313.00)	36919 (164.22)	4.27 (6.86)	1900	3.4	0.418 (0.254)	16.72 (3.29)	0.046 (0.028)	198 (92)	55 (13)	28.79 (97.49)
5th Gear										
423.91 (316.11)	32176 (143.13)	4.94 (7.95)	1900	2.6	0.414 (0.252)	16.89 (3.33)	0.045 (0.028)	201 (94)	55 (13)	28.79 (97.49)
6th Gear										
424.04 (316.20)	29143 (129.63)	5.46 (8.79)	1900	2.0	0.414 (0.252)	16.91 (3.33)	0.045 (0.027)	200 (93)	55 (13)	28.80 (97.53)
7th Gear										
423.55 (315.84)	26451 (117.66)	6.01 (9.66)	1900	1.7	0.414 (0.252)	16.90 (3.33)	0.045 (0.027)	202 (94)	55 (13)	28.80 (97.53)
8th Gear										
421.89 (314.60)	23910 (106.35)	6.62 (10.65)	1900	1.4	0.416 (0.253)	16.82 (3.31)	0.045 (0.027)	200 (93)	56 (13)	28.79 (97.49)
9th Gear										
423.08 (315.49)	21767 (96.82)	7.29 (11.73)	1900	1.2	0.415 (0.253)	16.84 (3.32)	0.045 (0.027)	201 (94)	57 (14)	28.79 (97.49)
10th Gear										
421.08 (314.00)	19684 (87.56)	8.02 (12.91)	1900	1.0	0.416 (0.253)	16.81 (3.31)	0.045 (0.027)	202 (94)	57 (14)	28.79 (97.49)

## HYDRAULIC PERFORMANCE

CATEGORY: IVN

Quick Attach: yes

OECD Static test

Maximum force exerted through whole range:	19728 lbs (87.8 kN)	
	<b>Three outlet sets combined</b>	
	<u>Standard pump</u>	<u>High flow pump</u>
i) Sustained pressure of the open relief valve:	2877 psi (198 bar)	3060 psi (211 bar)
ii) Pump delivery rate at minimum pressure and rated engine speed:	43.8 GPM (165.8 l/min)	60.4 GPM (228.5 l/min)
iii) Pump delivery rate at maximum hydraulic power:	43.3 GPM (163.7 l/min)	59.0 GPM (223.5 l/min)
Delivery pressure:	2526 psi (174 bar)	2682 psi (185 bar)
Power:	63.7 HP (47.5 kW)	92.4 Hp (68.9 kW)

	<b>Single outlet set</b>	
ii) Pump delivery rate at minimum pressure and rated engine speed:	42.8 GPM (162.2 l/min)	52.2 GPM (197.7 l/min)
iii) Pump delivery rate at maximum hydraulic power:	42.7 GPM (161.6 l/min)	48.7 GPM (184.3 l/min)
Delivery pressure:	2024 psi (139 bar)	2162 psi (149 bar)
Power:	50.4 HP (37.6 kW)	61.4 Hp (34.9 kW)

### TwinFlow system

	<b>Two outlet sets combined</b>	
	<u>Standard pump</u>	<u>TwinFlow pump</u>
i) Sustained pressure at compensator cutoff:	2877 psi (198 bar)	2855 psi (197 bar)
ii) Pump delivery rate at minimum pressure and rated engine speed:	43.8 GPM (165.8 l/min)	57.3 GPM (217.0 l/min)
Combined flow:	101.1 GPM (382.8 l/min)	
iii) Pump delivery rate at maximum hydraulic power:	43.3 GPM (163.7 l/min)	56.4 GPM (213.6 l/min)
Delivery pressure:	2526 psi (174 bar)	2479 psi (171 bar)
Power:	63.7 HP (47.5 kW)	81.6 Hp (60.9 kW)

	<b>Two outlet sets combined</b>	
	<u>High flow pump</u>	<u>TwinFlow pump</u>
i) Sustained pressure at compensator cutoff:	2993 psi (206 bar)	2855 psi (197 bar)
ii) Pump delivery rate at minimum pressure and rated engine speed:	61.0 GPM (230.9 l/min)	57.3 GPM (217.0 l/min)
Combined flow:	118.3 GPM (447.9 l/min)	
iii) Pump delivery rate at maximum hydraulic power:	56.7 GPM (214.7 l/min)	56.4 GPM (213.6 l/min)
Delivery pressure:	2517 psi (174 bar)	2479 psi (171 bar)
Power:	83.3 HP (62.1 kW)	81.6 Hp (60.9 kW)

## HITCH DIMENSIONS AS TESTED - NO LOAD

	inch	mm
A	32.6	827
B	29.9	760
C	23.2	590
D	22.0	558
E	13.5	342
F	13.4	340
G	35.0	890
*G'	11.8	300
H	4.6	117
I	22.8	578
J	21.6	550
K	29.0	736
L	56.3	1431
*L'	63.6	1615
M	34.3	871
N	46.5	1181
O	7.9	200
P	45.4	1154
Q	40.9	1039
R	38.5	978

\*G' to undercarriage pivot point  
\*L' to Quick coupler ends

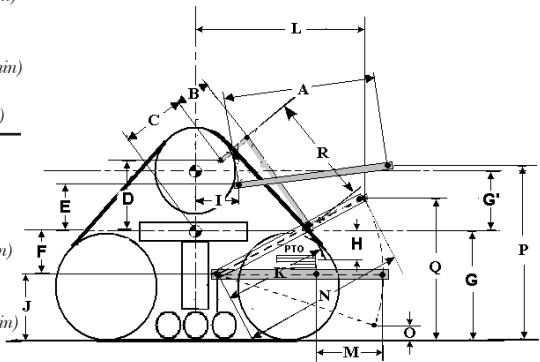

NTTL.(2017). Nebraska OECD tractor test 2186 for Case IH Steiger 470 Quadtrac Diesel. Lincoln, NE:Nebraska Tractor Test Laboratory. Retrieved from <http://tractortestlab.unl.edu>



**Case IH Steiger 470 Quadtrac Diesel**

Institute of Agriculture and Natural Resources  
University of Nebraska-Lincoln