

University of Nebraska - Lincoln

DigitalCommons@University of Nebraska - Lincoln

---

Nebraska Tractor Tests

Tractor Test and Power Museum, The Lester F.  
Larsen

---

2017

## Test 2188: Case IH Steiger 540 QuadTrac

Nebraska Tractor Test Lab

University of Nebraska-Lincoln, [tractortestlab@unl.edu](mailto:tractortestlab@unl.edu)

Follow this and additional works at: <https://digitalcommons.unl.edu/tractormuseumlit>



Part of the [Energy Systems Commons](#), [History of Science, Technology, and Medicine Commons](#), [Other Mechanical Engineering Commons](#), [Physical Sciences and Mathematics Commons](#), [Science and Mathematics Education Commons](#), and the [United States History Commons](#)

---

Nebraska Tractor Test Lab, "Test 2188: Case IH Steiger 540 QuadTrac" (2017). *Nebraska Tractor Tests*. 2652.

<https://digitalcommons.unl.edu/tractormuseumlit/2652>

This Article is brought to you for free and open access by the Tractor Test and Power Museum, The Lester F. Larsen at DigitalCommons@University of Nebraska - Lincoln. It has been accepted for inclusion in Nebraska Tractor Tests by an authorized administrator of DigitalCommons@University of Nebraska - Lincoln.

# NEBRASKA OECD TRACTOR TEST 2188 - SUMMARY 1119

## CASE IH STEIGER 540 QUADTRAC DIESEL

### 16 SPEED

#### POWER TAKE-OFF PERFORMANCE

Power HP (kW)	Crank shaft speed rpm	Diesel Consumption Gal/hr (l/h)	D.E.F. Consumption			Mean Atmospheric Conditions
			lb/hp.hr (kg/kW.h)	Hp.hr/gal (kW.h/l)	Gal/hr (l/h)	
<b>MAXIMUM POWER AND FUEL CONSUMPTION</b>						
<b>Rated Engine Speed—(PTO speed—1160 rpm)</b>						
480.46 (358.28)	2101	26.21 (99.20)	0.381 (0.232)	18.33 (3.61)	2.46 (9.32)	
<b>Maximum Power (1 hour)</b>						
541.99 (404.16)	1900	27.81 (105.27)	0.359 (0.218)	19.49 (3.84)	2.86 (10.84)	
<b>Standard Power Take-off Speed (1000 rpm)</b>						
536.10 (399.77)	1811	27.20 (102.94)	0.355 (0.216)	19.71 (3.88)	2.70 (10.24)	

#### VARYING POWER AND FUEL CONSUMPTION

480.46 (358.28)	2101	26.21 (99.20)	0.381 (0.232)	18.33 (3.61)	2.46 (9.32)	Air temperature
417.36 (311.23)	2147	23.63 (89.44)	0.396 (0.241)	17.66 (3.48)	2.09 (7.92)	76°F (25°C)
314.89 (234.81)	2159	18.80 (71.18)	0.418 (0.254)	16.75 (3.30)	1.62 (6.13)	Relative humidity
211.08 (157.41)	2170	14.07 (53.25)	0.466 (0.284)	15.01 (2.96)	1.12 (4.26)	26%
106.09 (79.11)	2180	9.63 (36.46)	0.635 (0.386)	11.02 (2.17)	0.65 (2.45)	Barometer
3.54 (2.64)	2190	5.24 (19.85)	10.345 (6.293)	0.68 (0.13)	0.25 (0.96)	28.98" Hg (98.14 kPa)

Maximum torque - 1784 lb-ft (2419 Nm) at 1400 rpm

Maximum torque rise - 48.5%

Torque rise at 1681 engine rpm - 38%

Power increase at 1900 engine rpm - 12.8%

#### DRAWBAR PERFORMANCE FUEL CONSUMPTION CHARACTERISTICS

Power Hp (kW)	Drawbar pull lbs (kN)	Speed mph (km/h)	Crank- shaft speed rpm	Slip %	Fuel Consumption lb/hp.hr (kg/kW.h)	D.E.F. Consumption Hp.hr/gal (kW.h/l)	Temp. °F (°C)	Barom. inch Hg (kPa)
<b>Power at Rated Engine Speed—4th Gear</b>								
423.76 (315.99)	33665 (149.75)	4.72 (7.60)	2100	2.8	0.433 (0.263)	16.15 (3.18)	0.050 (0.031)	194 55 28.86 (90) (13) (97.73)
<b>75% of Pull at Rated Engine Speed—4th Gear</b>								
329.00 (245.33)	25197 (112.08)	4.90 (7.89)	2153	1.7	0.454 (0.276)	15.40 (3.03)	0.047 (0.029)	193 64 28.84 (89) (18) (97.66)
<b>50% of Pull at Rated Engine Speed—4th Gear</b>								
222.17 (165.67)	16781 (74.65)	4.97 (7.99)	2164	0.8	0.536 (0.326)	13.04 (2.57)	0.036 (0.022)	184 66 28.84 (84) (19) (97.66)
<b>75% of Pull at Reduced Engine Speed—8th Gear</b>								
328.75 (245.15)	25182 (112.01)	4.90 (7.88)	1417	1.7	0.391 (0.238)	17.87 (3.52)	0.041 (0.025)	183 65 28.84 (84) (19) (97.66)
<b>50% of Pull at Reduced Engine Speed—8th Gear</b>								
222.27 (165.75)	16723 (74.39)	4.98 (8.01)	1429	0.8	0.424 (0.258)	16.48 (3.25)	0.043 (0.026)	180 68 28.83 (82) (20) (97.63)

**Location of tests:** Nebraska Tractor Test Laboratory, University of Nebraska, Lincoln Nebraska 68583-0832

**Dates of tests:** October 16 - 20, 2017

**Manufacturer:** CNH Industrial America LLC, 700 State Street Racine, Wi. 53404 USA.

**CONSUMABLE Fluids, OIL and TIME: Fuel** No. 2 Diesel **Specific gravity converted to 60°/60°F (15°/15°C)** 0.8400 **Fuel weight** 6.994 lbs/gal (0.838 kg/l) **Diesel Exhaust Fluid (DEF)** 32% aqueous urea solution **DEF weight** 9.071 lbs/gal (1.087 kg/l) **Oil SAE 10W40 API service classification CJ-4 Transmission lubricant Akcela Hy-Tran Ultraction fluid Hydraulic and axle lubricant Akcela Hy-Tran Ultraction fluid Total time engine was operated:** 15.5 hours

**ENGINE: Make** F.P.T. **Diesel Type** six cylinder vertical with two turbochargers, two stage air to water intercooler and D.E.F. (diesel exhaust fluid) exhaust treatment **Serial No.** 000009660 **Crankshaft** lengthwise **Rated engine speed** 2100 **Bore and stroke** 5.315" x 5.906" (135.0 mm x 150.0 mm) **Compression ratio** 15.5 to 1 **Displacement** 786 cu in (12880 ml) **Starting system** 24 volt **Lubrication** pressure **Air cleaner** two paper elements and aspirator **Oil filter** one full flow cartridge **Oil cooler** engine coolant heat exchanger for crankcase oil, separate radiators for hydraulic and transmission oil **Fuel filter** two paper elements **Fuel cooler** radiator for pump return fuel **Exhaust** DOC (diesel oxidation catalyst) and SCR (selective catalyst reduction) within a vertical muffler **Cooling medium temperature control** thermostat and variable speed fan

**ENGINE OPERATING PARAMETERS: Fuel rate:** 180.1 - 191.1 lb/h (81.7 - 86.7 kg/h) **High idle:** 2175 - 2225 rpm **Turbo boost:** nominal 38.4 - 41.3 psi (265 - 285 kPa) as measured 40.3 psi (278 kPa)

**CHASSIS: Type** 4WD with rubber tracks **Serial No.** \*ZHF312056\* **Track width** rear 88.0" (2235 mm) front 88.0" (2235 mm) **Trackbase** 154.0" (3912 mm) **Length of track on ground** 29.4" (748 mm) **Hydraulic control system** direct engine drive **Transmission** selective gear fixed ratio with full range operator controlled powershift **Nominal travel speeds mph (km/h)** first 2.77 (4.45) second 3.33 (5.36) third 4.03 (6.48) fourth 4.85 (7.80) fifth 5.57 (8.96) sixth 6.11 (9.84) seventh 6.70 (10.79) eighth 7.37 (11.86) ninth 8.10 (13.03) tenth 8.90 (14.32) eleventh 9.76 (15.70) twelfth 10.72 (17.25) thirteenth 12.31 (19.81) fourteenth 14.83 (23.86) fifteenth 17.90 (28.81) sixteenth 21.01 (33.81) reverse 4.21 (6.77), 9.30 (14.97)

**DRAWBAR PERFORMANCE AT 2100 ENGINE RPM  
MAXIMUM POWER IN SELECTED GEARS**

Power Hp (kW)	Drawbar pull lbs (kN)	Speed mph (km/h)	Crank- shaft speed rpm	Slip %	Fuel Consumption lb/hp.hr (kg/kW.h)	Hp.hr/gal (kW.h/l)	D.E.F. Consumption lb/hp.hr (kg/kW.h)	Temp. °F (°C) cool- ing med	Air dry bulb	Barom. inch Hg (kPa)
1st Gear										
371.11 (276.73)	55844 (248.40)	2.50 (4.02)	2109	10.5	0.473 (0.288)	14.80 (2.91)	0.053 (0.032)	198 (92)	52 (11)	28.69 (97.16)
2nd Gear										
409.24 (305.17)	49311 (219.35)	3.12 (5.01)	2100	6.9	0.449 (0.273)	15.59 (3.07)	0.052 (0.031)	196 (91)	54 (12)	28.69 (97.16)
3rd Gear										
422.02 (314.70)	41004 (182.39)	3.86 (6.21)	2099	4.3	0.435 (0.265)	16.06 (3.16)	0.050 (0.030)	195 (91)	56 (13)	28.68 (97.12)
4th Gear										
423.76 (315.99)	33665 (149.75)	4.72 (7.60)	2100	2.8	0.433 (0.263)	16.15 (3.18)	0.050 (0.031)	194 (90)	55 (13)	28.86 (97.73)
5th Gear										
426.02 (317.68)	29281 (130.25)	5.46 (8.79)	2099	2.1	0.431 (0.262)	16.25 (3.20)	0.051 (0.031)	194 (90)	56 (13)	28.87 (97.77)
6th Gear										
425.86 (317.56)	26545 (118.08)	6.02 (9.68)	2099	1.8	0.431 (0.262)	16.22 (3.20)	0.050 (0.031)	193 (89)	58 (15)	28.86 (97.73)
7th Gear										
423.54 (315.83)	24010 (106.80)	6.62 (10.65)	2100	1.5	0.434 (0.264)	16.13 (3.18)	0.051 (0.031)	195 (91)	59 (15)	28.86 (97.73)
8th Gear										
422.35 (314.95)	21740 (96.70)	7.29 (11.72)	2099	1.2	0.434 (0.264)	16.11 (3.17)	0.051 (0.031)	193 (89)	62 (16)	28.84 (97.66)
9th Gear										
418.17 (311.83)	19535 (86.89)	8.03 (12.92)	2100	1.1	0.439 (0.267)	15.92 (3.14)	0.051 (0.031)	194 (90)	63 (17)	28.84 (97.66)

**Clutch** multiple wet disc electro-hydraulically operated by foot pedal **Brakes** single wet disc hydraulically actuated by foot pedal **Steering** hydrostatic and articulated **Power take-off** 1000 rpm at 1811 engine rpm **Unladen tractor mass** 57695 lb (26170 kg)

**REPAIRS AND ADJUSTMENTS:** No repairs or adjustments.

**NOTE 1:** This tractor has a driveline protection system that limits the maximum engine torque in gears 1 through 4.

**REMARKS:** All test results were determined from observed data obtained in accordance with official OECD, SAE and Nebraska test procedures. The performance figures on this Summary were taken from a test conducted under the OECD Code 2 test procedure.

We, the undersigned, certify that this is a true and correct report of official Tractor Test No. **2188**, Nebraska Summary 1119, December 11, 2017.

Roger M. Hoy  
Director

M.F. Kocher  
J.D. Luck  
S.K. Pitla  
Board of Tractor Test Engineers

TRACTOR SOUND LEVEL WITH CAB	dB(A)
At no load in 4th gear	74.4
Bystander in 15th Gear	88.7

Horizontal distances of drawbar hitch point behind rear wheel axis - 49.2"(1250 mm), 55.1"(1400 mm)

**TRACKS AND WEIGHT**

Rear tracks - no & size  
Front tracks - no & size  
Height of drawbar  
Static weight with operator- Rear  
- Front  
- Total

**Tested Without Ballast**

2 x 30.0 in (762 mm)  
2 x 30.0 in (762 mm)  
20.5 in (520 mm)  
22900 lb (10387 kg)  
34970 lb (15862 kg)  
57870 lb (26249 kg)

**DRAWBAR PERFORMANCE AT 1900 ENGINE RPM**  
**MAXIMUM POWER IN SELECTED GEARS**

Power Hp (kW)	Drawbar pull lbs (kN)	Speed mph (km/h)	Crank- shaft speed rpm	Slip %	Fuel Consumption lb/hp.hr (kg/kW.h)	Hp.hr/gal (kW.hr/l)	D.E.F. Consumption lb/hp.hr (kg/kW.h)	Temp.°F cool- ing med	°C Air dry bulb	Barom. inch Hg (kPa)
370.62 (276.37)	55895 (248.63)	2.49 (4.01)	2109	10.7	1st Gear 0.473 (0.288)	14.79 (2.91)	0.053 (0.032)	199 (93)	52 (11)	28.69 (97.16)
420.63 (313.66)	54269 (241.40)	2.91 (4.68)	2018	9.5	2nd Gear 0.451 (0.274)	15.51 (3.06)	0.053 (0.032)	196 (91)	55 (13)	28.68 (97.12)
457.72 (341.32)	50928 (226.54)	3.37 (5.42)	1900	7.7	3rd Gear 0.425 (0.259)	16.45 (3.24)	0.051 (0.031)	202 (94)	57 (14)	28.68 (97.12)
471.50 (351.59)	42118 (187.35)	4.20 (6.76)	1900	4.5	4th Gear 0.413 (0.251)	16.95 (3.34)	0.051 (0.031)	196 (91)	55 (13)	28.86 (97.73)
477.23 (355.87)	36694 (163.22)	4.88 (7.85)	1900	3.3	5th Gear 0.408 (0.248)	17.15 (3.38)	0.051 (0.031)	198 (92)	56 (14)	28.87 (97.77)
478.50 (356.82)	33304 (148.14)	5.39 (8.67)	1899	2.7	6th Gear 0.406 (0.247)	17.21 (3.39)	0.051 (0.031)	198 (92)	59 (15)	28.86 (97.73)
478.48 (356.80)	30243 (134.53)	5.94 (9.55)	1899	2.4	7th Gear 0.406 (0.247)	17.21 (3.39)	0.051 (0.031)	198 (92)	60 (16)	28.85 (97.70)
478.27 (356.65)	27398 (121.87)	6.55 (10.54)	1899	1.9	8th Gear 0.407 (0.248)	17.19 (3.39)	0.051 (0.031)	198 (92)	63 (17)	28.85 (97.70)
477.41 (356.00)	24789 (110.27)	7.22 (11.62)	1900	1.6	9th Gear 0.407 (0.248)	17.18 (3.38)	0.051 (0.031)	197 (92)	63 (17)	28.85 (97.70)
475.68 (354.71)	22312 (99.25)	8.00 (12.87)	1909	1.3	10th Gear 0.409 (0.249)	17.12 (3.37)	0.051 (0.031)	200 (93)	64 (18)	28.85 (97.70)

## HYDRAULIC PERFORMANCE

CATEGORY: IVN

Quick Attach: yes

OECD Static test

Maximum force exerted through whole range:	19728 lbs (87.8 kN)	
	<b>Three outlet sets combined</b>	
	<u>Standard pump</u>	<u>High flow pump</u>
i) Sustained pressure of the open relief valve:	2877 psi (198 bar)	3099 psi (214 bar)
ii) Pump delivery rate at minimum pressure and rated engine speed:	43.8 GPM (165.8 l/min)	60.5 GPM (228.9 l/min)
iii) Pump delivery rate at maximum hydraulic power:	43.3 GPM (163.7 l/min)	59.8 GPM (226.4 l/min)
Delivery pressure:	2526 psi (174 bar)	2601 psi (179 bar)
Power:	63.7 HP (47.5 kW)	90.8 Hp (67.7 kW)
	<b>Single outlet set</b>	
ii) Pump delivery rate at minimum pressure and rated engine speed:	42.8 GPM (162.2 l/min)	51.9 GPM (196.4 l/min)
iii) Pump delivery rate at maximum hydraulic power:	42.7 GPM (161.6 l/min)	39.0 GPM (147.7 l/min)
Delivery pressure:	2024 psi (139 bar)	2107 psi (145 bar)
Power:	50.4 HP (37.6 kW)	48.0 Hp (35.8 kW)

### TwinFlow system

	<b>Two outlet sets combined</b>	
	<u>Standard pump</u>	<u>TwinFlow pump</u>
i) Sustained pressure at compensator cutoff:	2877 psi (198 bar)	2855 psi (197 bar)
ii) Pump delivery rate at minimum pressure and rated engine speed:	43.8 GPM (165.8 l/min)	57.3 GPM (217.0 l/min)
Combined flow:	101.1 GPM (382.8 l/min)	
iii) Pump delivery rate at maximum hydraulic power:	43.3 GPM (163.7 l/min)	56.4 GPM (213.6 l/min)
Delivery pressure:	2526 psi (174 bar)	2479 psi (171 bar)
Power:	63.7 HP (47.5 kW)	81.6 Hp (60.9 kW)

	<b>Two outlet sets combined</b>	
	<u>High flow pump</u>	<u>TwinFlow pump</u>
i) Sustained pressure at compensator cutoff:	2993 psi (206 bar)	2855 psi (197 bar)
ii) Pump delivery rate at minimum pressure and rated engine speed:	61.0 GPM (230.9 l/min)	57.3 GPM (217.0 l/min)
Combined flow:	118.3 GPM (447.9 l/min)	
iii) Pump delivery rate at maximum hydraulic power:	56.7 GPM (214.7 l/min)	56.4 GPM (213.6 l/min)
Delivery pressure:	2517 psi (174 bar)	2479 psi (171 bar)
Power:	83.3 HP (62.1 kW)	81.6 Hp (60.9 kW)

### HITCH DIMENSIONS AS TESTED - NO LOAD

	inch	mm
A	32.6	827
B	29.9	760
C	23.2	590
D	22.0	558
E	13.5	342
F	13.4	340
G	35.0	890
*G'	11.8	300
H	4.6	117
I	22.8	578
J	21.6	550
K	29.0	736
L	56.3	1431
*L'	63.6	1615
M	34.3	871
N	46.5	1181
O	7.9	200
P	45.4	1154
Q	40.9	1039
R	38.5	978

\*G' to undercarriage pivot point  
\*L' to Quick coupler ends

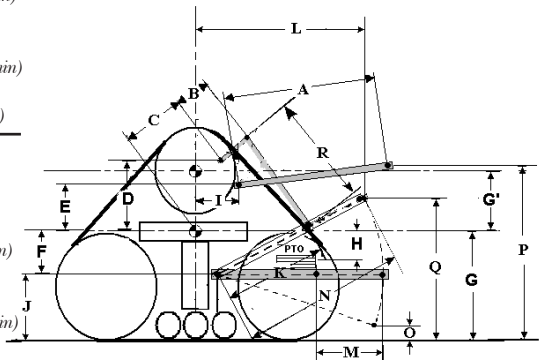

NTTL.(2017). Nebraska OECD tractor test 2188 for Case IH Steiger 540 Quadtrac Diesel. Lincoln, NE:Nebraska Tractor Test Laboratory. Retrieved from <http://tractortestlab.unl.edu>



**Case IH Steiger 540 Quadtrac Diesel**

Institute of Agriculture and Natural Resources  
University of Nebraska-Lincoln