

University of Nebraska - Lincoln

DigitalCommons@University of Nebraska - Lincoln

Nebraska Tractor Tests

Tractor Test and Power Museum, The Lester F. Larsen

2018

Test 2205: Challenger MT738

Nebraska Tractor Test Lab

University of Nebraska-Lincoln, tractortestlab@unl.edu

Follow this and additional works at: <https://digitalcommons.unl.edu/tractormuseumlit>



Part of the [Energy Systems Commons](#), [History of Science, Technology, and Medicine Commons](#), [Other Mechanical Engineering Commons](#), [Physical Sciences and Mathematics Commons](#), [Science and Mathematics Education Commons](#), and the [United States History Commons](#)

Nebraska Tractor Test Lab, "Test 2205: Challenger MT738" (2018). *Nebraska Tractor Tests*. 2632.
<https://digitalcommons.unl.edu/tractormuseumlit/2632>

This Article is brought to you for free and open access by the Tractor Test and Power Museum, The Lester F. Larsen at DigitalCommons@University of Nebraska - Lincoln. It has been accepted for inclusion in Nebraska Tractor Tests by an authorized administrator of DigitalCommons@University of Nebraska - Lincoln.

NEBRASKA OECD TRACTOR TEST 2205—SUMMARY 1154

CHALLENGER MT738 DIESEL

CONTINUOUSLY VARIABLE TRANSMISSION

POWER TAKE-OFF PERFORMANCE

Power HP (kW)	Crank shaft speed rpm	Diesel Consumption		D.E.F. Consumption		Mean Atmospheric Conditions
		Gal/hr (l/h)	lb/hp.hr (kg/kW.h)	Hp.hr/gal (kW.h/l)	Gal/hr (l/h)	
MAXIMUM POWER AND FUEL CONSUMPTION						
Rated Engine Speed—(PTO speed—1054rpm)						
324.64 (242.08)	1701	17.37 (65.76)	0.374 (0.228)	18.69 (3.68)	0.81 (3.08)	
Standard Power Take-off Speed (1000 rpm)						
323.90 (241.53)	1614	17.17 (64.98)	0.371 (0.226)	18.87 (3.72)	0.81 (3.06)	
Power at 1600 Engine RPM (1 hour)						
324.54 (242.01)	1599	17.15 (64.92)	0.370 (0.225)	18.92 (3.73)	0.82 (3.09)	

VARYING POWER AND FUEL CONSUMPTION

324.64 (242.08)	1701	17.37 (65.76)	0.374 (0.228)	18.69 (3.68)	0.81 (3.08)	Air temperature
279.27 (208.25)	1722	15.26 (57.75)	0.382 (0.233)	18.30 (3.61)	0.67 (2.55)	71°F (22°C)
211.40 (157.64)	1738	12.13 (45.90)	0.401 (0.244)	17.43 (3.43)	0.57 (2.14)	Relative humidity
142.20 (106.04)	1752	9.11 (34.49)	0.448 (0.273)	15.61 (3.07)	0.39 (1.47)	49%
71.48 (53.30)	1763	6.07 (22.96)	0.594 (0.361)	11.78 (2.32)	0.25 (0.96)	Barometer
2.58 (1.92)	1775	3.32 (12.58)	9.016 (5.484)	0.78 (0.15)	0.15 (0.57)	28.58" Hg (96.77 kPa)

Maximum torque - 1120 lb.-ft. (1573 Nm) at 1275 rpm
 Maximum torque rise - 11.7%
 Torque rise at 1351 engine rpm - 10.5%
 Power increase at 1599 engine rpm - 0%

DRAWBAR PERFORMANCE

FUEL CONSUMPTION CHARACTERISTICS

Power Hp (kW)	Drawbar pull lbs (kN)	Speed mph (km/h)	Crank- shaft speed rpm	Slip %	Fuel Consumption lb/hp.hr (kg/kW.h)	D.E.F. Consumption Hp.hr/gal (kW.h/l)	Temp. °F(°C) cool- ing med bulb	Barom. inch Hg (kPa)
Power at Rated Engine Speed—5.6 mph (9.0 km/h)								
267.07 (199.15)	17995 (80.04)	5.57 (8.96)	1700	2.1	0.455 (0.277)	15.37 (3.03)	205 (96)	43 (6)
75% of Pull at Rated Engine Speed—5.6 mph (9.0 km/h)								
201.46 (150.23)	13462 (59.88)	5.61 (9.03)	1723	1.1	0.476 (0.290)	14.69 (2.89)	205 (96)	47 (8)
50% of Pull at Rated Engine Speed—5.6 mph (9.0 km/h)								
135.04 (100.70)	8981 (39.95)	5.64 (9.08)	1737	0.5	0.532 (0.324)	13.14 (2.59)	205 (96)	47 (8)
75% of Pull at Reduced Engine Speed—7.5 mph (12.0 km/h)								
201.49 (150.25)	13440 (59.78)	5.62 (9.04)	1281	1.1	0.429 (0.261)	16.31 (3.21)	207 (97)	47 (8)
50% of Pull at Reduced Engine Speed—8.0 mph (13.0 km/h)								
135.35 (100.93)	8975 (39.92)	5.66 (9.11)	1194	0.6	0.452 (0.275)	15.48 (3.05)	203 (95)	47 (8)

Location of tests: Nebraska Tractor Test Laboratory, University of Nebraska, Lincoln, Nebraska 68583-0832

Dates of tests: October 9 to 19, 2018

Manufacturer: AGCO Corporation, 4205 River Green Parkway, Duluth Ga 30096

CONSUMABLE Fluids, OIL and TIME: Fuel No. 2 Diesel **Specific gravity converted to 60°/60°F (15°/15°C)** 0.8404 **Fuel weight** 6.998 lbs/gal (0.839 kg/l) **Diesel Exhaust Fluid (DEF)** 32% aqueous urea solution **DEF weight** 9.071 lbs/gal (1.087 kg/l) **Oil** SAE 15W-40 **API service classification** CJ-4 **Transmission and hydraulic lubricant** AGCO Permatran 821 XL fluid **Total time engine was operated:** 24.0 hours

ENGINE: Make AGCO **Power Diesel Type** seven cylinder vertical with two turbochargers, water to air intercooler, air to air intercooler and D.E.F. (diesel exhaust fluid) technology **Serial No.** *D79629* **Crankshaft** lengthwise **Rated engine speed** 1700 **Bore and stroke** 4.370" x 5.709" (111.0 mm x 145.0 mm) **Compression ratio** 16.7 to 1 **Displacement** 599 cu in (9822 ml) **Starting system** 12 volt **Lubrication** pressure **Air cleaner** two paper elements and aspirator **Oil filter** one full flow cartridge **Oil cooler** engine coolant heat exchanger for crankcase oil, radiator for hydraulic and transmission oil **Fuel filter** one paper element and water separator **Fuel cooler** radiator for pump return fuel **Exhaust** DOC (diesel oxidation catalyst) and SCR (selective catalyst reduction) with a vertical muffler **Cooling medium temperature control** 2 thermostats and variable speed fan

ENGINE OPERATING PARAMETERS: Fuel rate: 121.0 - 132.9 lb/h (54.9 - 60.3 kg/h) **High idle:** 1765 - 1815 rpm **Turbo boost:** nominal 30.5 - 33.4 psi (210 - 230 kPa) as measured 33.1 psi (228 kPa)

CHASSIS: Type Tracklayer-rubber tracked **Serial No.** *AGCC0738JJNND1043* **Track width** 88.0" (2235 mm) to 119.5" (3035 mm) **Length of track on ground** 102.4" (2600 mm) **Hydraulic control system** direct engine drive **Transmission** CVT. Infinitely variable hydrostatic using variable displacement pump and motors **Nominal travel speeds mph (km/h)** forward - 0-25.0 mph (0-40 km/h), reverse - 0-8.7 mph (0-14 km/h) **Clutch** a foot pedal controls the hydrostatic oil flow **Brakes** wet multiple disc hydraulically actuated by foot pedal **Steering** electro-hydraulic differential steering controlled by steering wheel **Power take-off** 1000 rpm at 1614 or 1255 engine rpm **Unladen tractor mass** 36050 lb (16352 kg)

DRAWBAR PERFORMANCE

MANUAL MODE - 1700 ENGINE RPM DRAWBAR POWER AT SELECTED TRAVEL SPEED SETTINGS

Power Hp (kW)	Drawbar pull lbs (kN)	Speed mph (km/h)	Crank- shaft speed rpm	Slip %	Fuel Consumption lb/hp.hr (kg/kWh)	Hp.hr/gal (kW.h/l)	D.E.F. Consumption lb/hp.hr (kg/kWh)	Temp. °F(°C) cool- ing med	Air dry bulb	Barom. inch Hg (kPa)
2.5 mph (4.0 km/h)										
196.72 (146.69)	33899 (150.79)	2.18 (3.50)	1724	13.8	0.521 (0.317)	13.44 (2.65)	0.034 (0.021)	205 (96)	42 (6)	28.96 (98.07)
3.1 mph (5.0 km/h)										
244.18 (182.08)	32152 (143.02)	2.85 (4.59)	1696	10.0	0.491 (0.299)	14.26 (2.81)	0.031 (0.019)	206 (97)	43 (6)	28.96 (98.07)
3.7 mph (6.0 km/h)										
258.96 (193.11)	27180 (120.90)	3.58 (5.75)	1700	6.0	0.466 (0.283)	15.02 (2.96)	0.031 (0.019)	205 (96)	43 (6)	28.96 (98.07)
4.2 mph (6.8 km/h)										
261.32 (194.87)	23800 (105.87)	4.12 (6.63)	1700	4.4	0.465 (0.283)	15.05 (2.97)	0.029 (0.018)	206 (96)	43 (6)	28.59 (96.82)
4.7 mph (7.5 km/h)										
263.50 (196.49)	21305 (94.77)	4.64 (7.47)	1700	3.5	0.462 (0.281)	15.14 (2.98)	0.029 (0.018)	206 (97)	43 (6)	28.59 (96.82)
5.1 mph (8.2 km/h)										
266.11 (198.44)	19774 (87.96)	5.05 (8.13)	1700	2.6	0.457 (0.278)	15.31 (3.02)	0.029 (0.018)	205 (96)	43 (6)	28.59 (96.82)
5.6 mph (9.0 km/h)										
267.07 (199.15)	17995 (80.04)	5.57 (8.96)	1700	2.1	0.455 (0.277)	15.37 (3.03)	0.028 (0.017)	205 (96)	43 (6)	28.59 (96.82)
6.2 mph (10.0 km/h)										
267.22 (199.26)	16103 (71.63)	6.23 (10.02)	1700	1.6	0.452 (0.275)	15.48 (3.05)	0.029 (0.018)	205 (96)	43 (6)	28.59 (96.82)
6.8 mph (11.0 km/h)										
266.55 (198.76)	14583 (64.87)	6.86 (11.03)	1700	1.3	0.455 (0.277)	15.39 (3.03)	0.029 (0.018)	206 (97)	44 (7)	28.61 (96.88)
7.5 mph (12.0 km/h)										
266.54 (198.76)	13304 (59.18)	7.52 (12.09)	1700	1.0	0.455 (0.277)	15.39 (3.03)	0.030 (0.018)	209 (98)	45 (7)	28.62 (96.90)
8.1 mph (13.0 km/h)										
266.07 (198.41)	12244 (54.46)	8.15 (13.12)	1701	0.9	0.453 (0.275)	15.46 (3.05)	0.029 (0.018)	202 (94)	45 (7)	28.62 (96.92)

REPAIRS AND ADJUSTMENTS: No repairs or adjustments.

NOTE 1: To facilitate drawbar testing the tractor was operated in manual cruise mode.

REMARKS: All test results were determined from observed data obtained in accordance with official OECD, SAE and Nebraska test procedures. The performance figures on this summary were taken from a test conducted under the OECD Code 2 test procedure.

We, the undersigned, certify that this is a true and correct report of official Tractor Test No. **2205**, Nebraska Summary 1154, December 18, 2018.

Roger M. Hoy
Director

M.F. Kocher
J.D. Luck
P.J. Jasa
Board of Tractor Test Engineers

TRACTOR SOUND LEVEL WITH CAB

dB(A)

At no load at 4.6 mph (7.5 km/h) engine speed 1780 rpm	68.1
At no load at 4.6 mph (7.5 km/h) engine speed 1320 rpm	64.0
Bystander	83.8

Horizontal distance of drawbar hitch point behind rear wheel axis - 40.3" (1023 mm)

TRACKS AND WEIGHT

Tested Without Ballast

Track width	25.0 in (635 mm)
Height of Drawbar	20.5 in (520 mm)
Static Weight with operator	36225 lb (16431 kg)

DRAWBAR PERFORMANCE
MANUAL MODE - 1600 ENGINE RPM
DRAWBAR POWER AT SELECTED TRAVEL SPEED SETTINGS

Power Hp (kW)	Drawbar pull lbs (kN)	Speed mph (km/h)	Crank- shaft speed rpm	Slip %	Fuel Consumption lb/hp.hr (kg/kW.h)	Hp.hr/gal (kW.h/l)	D.E.F. Consumption lb/hp.hr (kg/kW.h)	Temp.°F(°C) cool- ing med	Air dry bulb	Barom. inch Hg (kPa)
2.5 mph (4.0 km/h)										
198.52 (148.04)	34087 (151.63)	2.19 (3.52)	1724	13.6	0.522 (0.318)	13.40 (2.64)	0.034 (0.020)	205 (96)	41 (5)	28.96 (98.07)
3.1 mph (5.0 km/h)										
244.75 (182.51)	32242 (143.42)	2.85 (4.58)	1702	10.1	0.484 (0.294)	14.47 (2.85)	0.033 (0.020)	205 (96)	43 (6)	28.96 (98.07)
3.7 mph (6.0 km/h)										
258.97 (193.11)	27391 (121.84)	3.55 (5.71)	1658	5.9	0.464 (0.282)	15.09 (2.97)	0.031 (0.018)	205 (96)	43 (6)	28.96 (98.07)
4.2 mph (6.8 km/h)										
264.22 (197.03)	24264 (107.93)	4.09 (6.57)	1600	4.6	0.454 (0.276)	15.41 (3.04)	0.029 (0.017)	205 (96)	43 (6)	28.59 (96.82)
4.7 mph (7.5 km/h)										
265.81 (198.21)	21621 (96.17)	4.61 (7.42)	1600	3.5	0.451 (0.274)	15.52 (3.06)	0.029 (0.017)	206 (96)	43 (6)	28.59 (96.82)
5.1 mph (8.2 km/h)										
267.90 (199.77)	20085 (89.34)	5.00 (8.05)	1600	2.7	0.447 (0.272)	15.66 (3.08)	0.029 (0.018)	204 (96)	43 (6)	28.59 (96.82)
5.6 mph (9.0 km/h)										
269.67 (201.09)	18271 (81.27)	5.54 (8.91)	1601	2.1	0.445 (0.271)	15.73 (3.10)	0.028 (0.017)	204 (96)	43 (6)	28.59 (96.82)
6.2 mph (10.0 km/h)										
270.16 (201.45)	16429 (73.08)	6.17 (9.92)	1600	1.7	0.444 (0.270)	15.76 (3.10)	0.029 (0.018)	205 (96)	45 (7)	28.61 (96.88)
6.8 mph (11.0 km/h)										
268.01 (199.85)	14758 (65.65)	6.81 (10.96)	1600	1.3	0.448 (0.273)	15.61 (3.08)	0.029 (0.018)	206 (96)	45 (7)	28.61 (96.88)
7.5 mph (12.0 km/h)										
269.11 (200.67)	13554 (60.29)	7.45 (11.98)	1600	1.1	0.446 (0.271)	15.68 (3.09)	0.031 (0.019)	209 (98)	45 (7)	28.62 (96.92)
8.1 mph (13.0 km/h)										
267.66 (199.59)	12403 (55.17)	8.10 (13.03)	1600	0.9	0.448 (0.272)	15.62 (3.08)	0.030 (0.019)	206 (97)	45 (7)	28.62 (96.92)

Shiftable PTO Performance

Economy mode

1000 PTO rpm @ 1255 engine rpm

Power HP (kW)	Crank shaft speed rpm	Diesel Consumption Gal/hr (l/h)	lb/hp.hr (kg/kW.h)	Hp.hr/gal (kW.h/l)	D.E.F. Consumption Gal/hr (l/h)
267.61 (199.56)	1255	13.77 (52.11)	0.360 (0.219)	19.44 (3.83)	1.14 (4.33)
200.45 (149.47)	1253	10.68 (40.41)	0.373 (0.227)	18.78 (3.70)	0.76 (2.87)
133.67 (99.68)	1254	7.61 (28.79)	0.398 (0.242)	17.57 (3.46)	0.41 (1.55)
67.05 (50.00)	1256	4.61 (17.44)	0.481 (0.292)	14.56 (2.87)	0.20 (0.75)
2.61 (1.05)	1258	1.96 (7.43)	5.259 (3.199)	1.33 (0.26)	0.08 (0.31)

Normal mode

1000 PTO rpm @ 1614 engine rpm

Power HP (kW)	Crank shaft speed rpm	Diesel Consumption Gal/hr (l/h)	lb/hp.hr (kg/kW.h)	Hp.hr/gal (kW.h/l)	D.E.F. Consumption Gal/hr (l/h)
267.58 (199.54)	1616	14.33 (54.25)	0.375 (0.228)	18.67 (3.68)	0.68 (2.58)
200.44 (149.47)	1610	11.20 (42.41)	0.391 (0.238)	17.89 (3.52)	0.55 (2.09)
133.67 (99.68)	1611	8.26 (31.27)	0.432 (0.263)	16.18 (3.19)	0.35 (1.31)
67.11 (50.04)	1616	5.39 (20.38)	0.562 (0.342)	12.46 (2.45)	0.20 (0.75)
2.60 (1.94)	1616	2.81 (10.64)	7.561 (4.599)	0.93 (0.18)	0.14 (0.51)

HYDRAULIC PERFORMANCE

CATEGORY: III

Quick Attach: yes

OECD Static test

Maximum force exerted through whole range: 21134 lbs (94.0 kN)

Pump 1 **Pump 2**

3 outlet sets combined

i) Sustained pressure at compensator cutoff:	2987 psi (206 bar)	2959 psi (204 bar)
ii) Pump delivery rate at minimum pressure and rated engine speed:	60.0 GPM (227.2 l/min)	60.3 GPM (228.4 l/min)
Combined flow:	120.3 GPM (455.6 l/min)	
iii) Pump delivery rate at maximum hydraulic power:	57.9 GPM (219.2 l/min)	59.0 GPM (223.5 l/min)
Delivery pressure:	2804 psi (193 bar)	2691 psi (186 bar)
Power:	94.7 HP (70.6 kW)	92.7 HP (69.1 kW)

single outlet set

i) Sustained pressure at compensator cutoff:	2884 psi (206 bar)	2960 psi (204 bar)
ii) Pump delivery rate at minimum pressure and rated engine speed:	37.4 GPM (141.5 l/min)	37.4 GPM (141.5 l/min)
iii) Pump delivery rate at maximum hydraulic power:	35.4 GPM (134.1 l/min)	36.3 GPM (137.3 l/min)
Delivery pressure:	2468 psi (170 bar)	2420 psi (167 bar)
Power:	51.0 HP (38.0 kW)	51.2 HP (38.2 kW)

HITCH DIMENSIONS AS TESTED—NO LOAD

	inch	mm
A	30.5	775
B	22.6	575
C	22.0	559
D	21.7	550
E	16.1	409
F	11.4	290
G	34.4	875
H	1.4	35
I	16.7	424
J	23.0	585
K	25.8	655
L	53.0	1347
*L'	59.2	1503
M	31.7	806
N	42.4	1076
O	9.0	230
P	50.0	1270
Q	43.5	1105
R	47.6	1210

*L' to Quick Attach ends

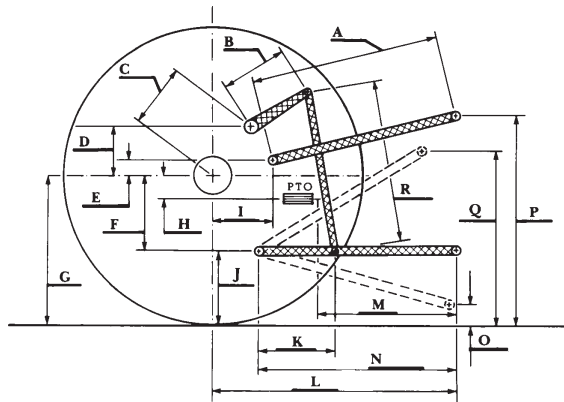

RECOMMENDED CITATION FORMAT:

NTTL.(2018). Nebraska OECD Tractor test 2205 for Challenger MT738 Diesel. Lincoln, NE:Nebraska Tractor Test Laboratory. Retrieved from <http://tractortestlab.unl.edu>



CHALLENGER MT738 DIESEL
Institute of Agriculture and Natural Resources
University of Nebraska–Lincoln