

University of Nebraska - Lincoln

DigitalCommons@University of Nebraska - Lincoln

Nebraska Tractor Tests

Tractor Test and Power Museum, The Lester F.
Larsen

2012

Nebraska Summary: S898 Massey Ferguson 7614

Nebraska Tractor Test Laboratory

University of Nebraska-Lincoln, tractortestlab@unl.edu

Follow this and additional works at: <https://digitalcommons.unl.edu/tractormuseumlit>



Part of the [Energy Systems Commons](#), [History of Science, Technology, and Medicine Commons](#), [Other Mechanical Engineering Commons](#), [Physical Sciences and Mathematics Commons](#), [Science and Mathematics Education Commons](#), and the [United States History Commons](#)

Laboratory, Nebraska Tractor Test, "Nebraska Summary: S898 Massey Ferguson 7614" (2012). *Nebraska Tractor Tests*. 3036.

<https://digitalcommons.unl.edu/tractormuseumlit/3036>

This Article is brought to you for free and open access by the Tractor Test and Power Museum, The Lester F. Larsen at DigitalCommons@University of Nebraska - Lincoln. It has been accepted for inclusion in Nebraska Tractor Tests by an authorized administrator of DigitalCommons@University of Nebraska - Lincoln.

SUMMARY OF OECD TEST 2754-NEBRASKA SUMMARY 898

MASSEY FERGUSON 7614 DYNA 4 DIESEL

16 SPEED

POWER TAKE-OFF PERFORMANCE

Power HP (kW)	Crank shaft speed rpm	Diesel Consumption		D.E.F. Consumption		Mean Atmospheric Conditions
		Gal/hr (l/h)	lb/hp.hr (kg/kW.h)	Hp.hr/gal (kW.h/l)	Gal/hr (l/h)	
MAXIMUM POWER AND FUEL CONSUMPTION						
Rated Engine Speed—(PTO speed—1035 rpm)						
121.2 (90.4)	2101	7.32 (27.72)	0.421 (0.256)	16.55 (3.26)	0.30 (1.15)	
Standard Power Take-off Speed (1000 rpm)						
132.6 (98.9)	2030	7.62 (28.86)	0.400 (0.244)	17.40 (3.43)	0.35 (1.31)	
Maximum Power (1 hour)						
135.6 (101.1)	2002	7.76 (29.38)	0.399 (0.243)	17.46 (3.44)	0.36 (1.36)	

VARYING POWER AND FUEL CONSUMPTION

121.2 (90.4)	2101	7.32 (27.72)	0.421 (0.256)	16.55 (3.26)	0.30 (1.15)	Air temperature
104.5 (77.9)	2121	6.44 (24.39)	0.431 (0.262)	16.21 (3.19)	0.25 (0.96)	74°F (23°C)
78.7 (58.7)	2128	5.32 (20.14)	0.472 (0.287)	14.79 (2.91)	0.22 (0.82)	Relative humidity
52.7 (39.3)	2139	4.12 (15.58)	0.545 (0.332)	12.78 (2.52)	0.16 (0.60)	46%
26.4 (19.7)	2146	2.93 (11.09)	0.774 (0.471)	9.00 (1.77)	0.10 (0.36)	Barometer
--	2152	1.99 (7.54)	--	--	--	29.7" Hg (100.7 kPa)

Maximum torque - 438.0 lb.-ft. (594.0 Nm) at 1200 rpm
 Maximum torque rise - 44.5%
 Torque rise at 1700 engine rpm - 37%
 Power increase at 2002 engine rpm - 11.8%

DRAWBAR PERFORMANCE (Unballasted - Front Drive Engaged) FUEL CONSUMPTION CHARACTERISTICS

Power Hp (kW)	Drawbar pull lbs (kN)	Speed mph (km/h)	Crank- shaft speed rpm	Slip %	Fuel Consumption lb/hp.hr (kg/kW.h)	Hp.hr/gal (kW.h/l)	Temp.°F (°C) cool- ing med	Air dry bulb	Barom. inch Hg (kPa)
Maximum Power—9th(3A) Gear									
100.6 (75.0)	6320 (28.1)	5.97 (9.60)	2099	4.2	0.461 (0.281)	15.07 (2.97)	183 (84)	73 (23)	29.8 (101.0)
75% of Pull at Maximum Power—9th(3A) Gear									
76.0 (56.7)	4725 (21.0)	6.03 (9.71)	2116	2.7	0.509 (0.310)	13.65 (2.69)	180 (82)	73 (23)	29.8 (101.0)
50% of Pull at Maximum Power—9th(3A) Gear									
49.2 (36.7)	3050 (13.6)	6.05 (9.74)	2140	1.9	0.612 (0.372)	11.37 (2.24)	180 (82)	75 (24)	29.8 (101.0)
75% of Pull at Reduced Engine Speed—10th(3B) Gear									
76.2 (56.8)	4765 (21.2)	5.99 (9.65)	1718	2.4	0.439 (0.267)	15.84 (3.12)	180 (82)	73 (23)	29.8 (101.0)
50% of Pull at Reduced Engine Speed—10th(3B) Gear									
50.2 (37.4)	3105 (13.8)	6.06 (9.75)	1725	1.6	0.509 (0.309)	13.66 (2.69)	178 (81)	73 (23)	29.8 (101.0)

Location of tests: IRSTEA, Centre d'Antony, 1 rue Pierre-Gilles de Gennes CS 10030 Antony, 92163, Cedex, France

Dates of tests: April - May, 2012

Manufacturer: AGCO S.A. BP 307, Avenue Blaise Pascal, 60026 Beauvais, France

FUEL and OIL: Fuel No. 2 Diesel Specific gravity converted to 60°/60°F (15°/15°C) 0.837 Fuel weight 6.97 lbs/gal (0.835 kg/l) Diesel Exhaust Fluid (DEF) 32% aqueous urea solution DEF weight 9.10 lbs/gal (1.091 kg/l) Oil SAE 15W40 API service classification CJ-4 Transmission and hydraulic lubricant BP Terrac Tractan 9 15W/40 Front axle lubricant BP Terrac Tractan 9 15W/40

ENGINE: Make Sisu AGCO Power Diesel Type six cylinder vertical with turbocharger and air to air intercooler and SCR (selective catalyst reduction) exhaust treatment **Serial No.** W00406 **Crankshaft** lengthwise **Rated engine speed 2100 Bore and stroke 4.252" x 4.724" (108.0 mm x 120.0 mm) Compression ratio 17.4 to 1 Displacement 402 cu in (6596 ml) Starting system 12 volt Lubrication pressure Air cleaner** two paper elements **Oil filter** one full flow cartridge **Oil cooler** engine coolant heat exchanger for crankcase oil, radiator for hydraulic and transmission oil **Fuel filter** two paper cartridges **Muffler** vertical **Cooling medium temperature control** thermostat and variable speed fan

CHASSIS: Type front wheel assist Serial No. B 230 901 **Tread width** rear 52.8" (1340 mm) to 87.8" (2230 mm) front 52.8" (1340 mm) to 87.8" (2230 mm) **Wheelbase 113.2" (2875 mm) Hydraulic control system** direct engine drive **Transmission** selective gear fixed ratio with partial (4) range operator controlled powershift **Nominal travel speeds mph (km/h)** first 1.24 (2.00) second 1.53 (2.46) third 1.86 (3.00) fourth 2.29 (3.69) fifth 2.95 (4.74) sixth 3.62 (5.83) seventh 4.42 (7.11) eighth 5.43 (8.74) ninth 5.98 (9.62) tenth 7.36 (11.84) eleventh 8.97 (14.44) twelfth 11.04 (17.76) thirteenth 13.79 (22.20) fourteenth 16.96 (27.30) fifteenth 20.69 (33.30) sixteenth 25.46 (40.97) reverse 1.24 (2.00), 1.53 (2.46), 1.86 (3.00), 2.29 (3.69), 2.95 (4.74), 3.62 (5.83), 4.42 (7.11), 5.43 (8.74), 5.98 (9.62), 7.36 (11.84), 8.97 (14.44), 11.04 (17.76), 13.79 (22.20), 16.96 (27.30), 20.69 (33.30), 25.46 (40.97)

DRAWBAR PERFORMANCE
(Unballasted - Front Drive Engaged)
MAXIMUM POWER IN SELECTED GEARS

Power Hp (kW)	Drawbar pull lbs (kN)	Speed mph (km/h)	Crank- shaft speed rpm	Slip %	Fuel Consumption lb/hp.hr (kg/kW.h)	Consumption Hp.hr/gal (kW.h/l)	Temp. °F(°C) cool- ing med	Air dry bulb	Barom. inch Hg (kPa)
5th(2A) Gear									
81.9 (61.1)	11735 (52.2)	2.62 (4.22)	2122	15.1	0.519 (0.316)	13.40 (2.64)	181 (83)	73 (23)	29.8 (101.0)
6th(2B) Gear									
98.3 (73.3)	11510 (51.2)	3.20 (5.15)	2060	12.0	0.489 (0.297)	14.21 (2.80)	180 (82)	72 (22)	29.8 (101.0)
7th(2C) Gear									
108.4 (80.8)	10140 (45.1)	4.01 (6.45)	2001	8.1	0.459 (0.279)	15.13 (2.98)	180 (82)	72 (22)	29.8 (101.0)
8th(2D) Gear									
111.0 (82.8)	8375 (37.2)	4.97 (8.00)	2000	5.8	0.450 (0.274)	15.43 (3.04)	181 (83)	72 (22)	29.8 (101.0)
9th(3A) Gear									
111.7 (83.3)	7575 (33.7)	5.53 (8.90)	2001	5.0	0.445 (0.271)	15.63 (3.08)	183 (84)	73 (23)	29.8 (101.0)
10th(3B) Gear									
112.0 (83.5)	6070 (27.0)	6.92 (11.13)	1994	4.0	0.446 (0.272)	15.57 (3.07)	185 (85)	73 (23)	29.8 (101.0)
11th(3C) Gear									
110.7 (82.6)	4880 (21.7)	8.51 (13.69)	2000	3.3	0.449 (0.273)	15.48 (3.05)	185 (85)	75 (24)	29.8 (101.0)
12th(3D) Gear									
107.1 (79.9)	3850 (17.1)	10.43 (16.79)	1992	2.8	0.469 (0.285)	14.82 (2.92)	187 (86)	73 (23)	29.8 (101.0)

Clutch multiple wet disc operated by foot pedal
Brakes multiple wet disc hydraulically operated by two foot pedals that can be locked together
Steering hydrostatic **Power take-off** 540 rpm at 1885 engine rpm or 1000 rpm at 2030 engine rpm
Unladen tractor mass 13920 lb (6315 kg)

REPAIRS AND ADJUSTMENTS: No repairs or adjustments.

NOTE: The performance figures on this report are the result of replacing the electronic engine control module of the Massey Ferguson 7615 with the Massey Ferguson 7614 module.

REMARKS: All test results were determined from observed data obtained in accordance with official OECD test procedures. This tractor did not meet the manufacturer's remote hydraulic flow claims of 29 GPM (110 lpm) with two outlets combined, 24.3 GPM (92 lpm) single outlet set nor 3 point lift capacity of 9800 lbs (4445 kg). The performance figures on this summary were taken from a test conducted under the OECD Code 2 test procedure.

We, the undersigned, certify that this is a true summary of data from OECD Report No. **2754**, Nebraska Summary 898, January 22, 2014.

Roger M. Hoy
 Director

M.F. Kocher
 J.D. Luck
 P.J. Jasa
 Board of Tractor Test Engineers

TRACTOR SOUND LEVEL WITH CAB	Front wheel drive	
	Engaged dB(A)	Disengaged dB(A)
At no load in 7th (2C) gear	69.0	69.0
Bystander		--

TIRES, BALLAST AND WEIGHT

Rear Tires - No., size, ply & psi(kPa)
Front Tires - No., size, ply & psi(kPa)
Height of Drawbar
Static Weight with operator - Rear
 - Front
 - Total

Tested without ballast

Two 520/85R38; **; 14(100)
 Two 420/85R28; **; 15(105)
 19.7 in (500 mm)
 7780 lb (3530 kg)
 6305 lb (2860 kg)
 14085 lb (6390 kg)

HYDRAULIC PERFORMANCE

CATEGORY: II

Quick Attach: None

OECD Static test

Maximum force exerted through whole range: 9305 lbs (41.4 kN)

i) Sustained pressure of the open relief valve: 2780 psi (191 bar)

two outlet sets combined

ii) Pump delivery rate at minimum pressure: 25.1 GPM (94.9 l/min)

iii) Pump delivery rate at maximum

hydraulic power: 23.4 GPM (88.9 l/min)

Delivery pressure: 2170 psi (149 bar)

Power: 29.6 HP (22.1 kW)

single outlet set

ii) Pump delivery rate at minimum pressure: 23.1 GPM (87.6 l/min)

iii) Pump delivery rate at maximum

hydraulic power: 22.1 GPM (83.6 l/min)

Delivery pressure: 1835 psi (126 bar)

Power: 23.6 HP (17.6 kW)

HITCH DIMENSIONS AS TESTED—NO LOAD

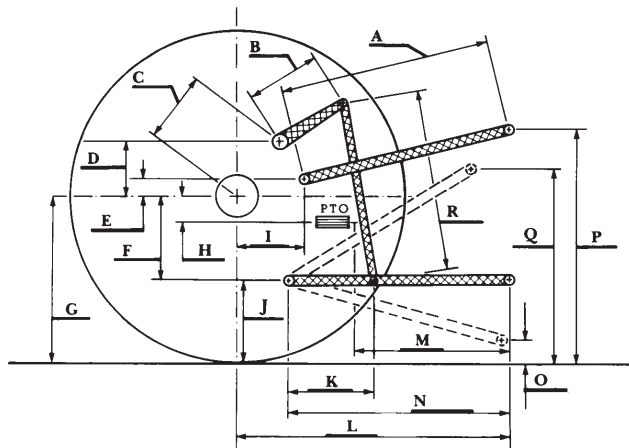

	inch	mm
A	27.7	704
B	11.6	295
C	13.9	354
D	13.0	330
E	9.8	250
F	11.0	280
G	34.4	875
H	3.2	82
I	16.3	413
J	23.4	595
K	21.4	543
L	43.3	1101
M	24.6	626
N	37.0	940
O	8.3	212
P	47.4	1205
Q	36.6	930
R	30.7	780