

University of Nebraska - Lincoln

DigitalCommons@University of Nebraska - Lincoln

Nebraska Tractor Tests

Tractor Test and Power Museum, The Lester F.
Larsen

2021

Test 2085A: John Deere 7R 250

Nebraska Tractor Test Lab

University of Nebraska-Lincoln, tractortestlab@unl.edu

Follow this and additional works at: <https://digitalcommons.unl.edu/tractormuseumlit>



Part of the [Energy Systems Commons](#), [History of Science, Technology, and Medicine Commons](#), [Other Mechanical Engineering Commons](#), [Physical Sciences and Mathematics Commons](#), [Science and Mathematics Education Commons](#), and the [United States History Commons](#)

Nebraska Tractor Test Lab, "Test 2085A: John Deere 7R 250" (2021). *Nebraska Tractor Tests*. 3459.
<https://digitalcommons.unl.edu/tractormuseumlit/3459>

This Article is brought to you for free and open access by the Tractor Test and Power Museum, The Lester F. Larsen at DigitalCommons@University of Nebraska - Lincoln. It has been accepted for inclusion in Nebraska Tractor Tests by an authorized administrator of DigitalCommons@University of Nebraska - Lincoln.

NEBRASKA OECD TRACTOR TEST 2085A—SUMMARY 934A

JOHN DEERE 7250R DIESEL

ALSO JOHN DEERE 7R 250 DIESEL

e23 TRANSMISSION

Location of tests: Nebraska Tractor Test Laboratory, University of Nebraska, Lincoln, Nebraska 68583-0832

Dates of tests: April 24 -30, 2014

Manufacturer: John Deere Tractor Works, 3500 East Donald Street, P.O. Box 270, Waterloo Ia, 50704-0270

CONSUMABLE Fluids, OIL and TIME: Fuel No. 2 Diesel **Specific gravity converted to 60°/60°F (15°/15°C)** 0.8410 **Fuel weight** 7.002 lbs/gal (0.839 kg/l) **Diesel Exhaust Fluid (DEF)** 32% aqueous urea solution **DEF weight** 9.071 lbs/gal (1.087 kg/l) **Oil SAE 10W-30 API service classification CJ-4 Transmission and hydraulic lubricant** John Deere Hy-Gard fluid **Front axle lubricant** John Deere Hy-Gard fluid **Total time engine was operated:** 23.5 hours

ENGINE: Make John Deere **Diesel Type** six cylinder vertical with two turbochargers, air to air aftercooler and D.E.F. (diesel exhaust fluid) exhaust treatment **Serial No.*** PE6068U001110* **Crankshaft** lengthwise **Rated engine speed** 2100 **Bore and stroke** 4.19" x 5.00" (106.5 mm x 127.0 mm) **Compression ratio** 16.0 to 1 **Displacement** 414 cu in (6788 ml) **Starting system** 12 volt **Lubrication** pressure **Air cleaner** two paper elements and aspirator **Oil filter** one full flow cartridge **Oil cooler** engine coolant heat exchanger for crankcase oil, radiator for hydraulic and transmission oil **Fuel filter** one paper element and prestrainer **Fuel cooler** radiator for pump return fuel **Exhaust** regenerative particulate filter integrated within a vertical muffler **Cooling medium temperature control** 2 thermostats and variable speed fan

ENGINE OPERATING PARAMETERS: Fuel rate: 81.7 - 88.5 lb/h (37.1 - 40.1 kg/h) **High idle:** 2150 - 2250 rpm **Turbo boost:** nominal 27.6 - 30.5 psi (190 - 210 kPa) as measured 29.3 psi (202 kPa)

CHASSIS: Type front wheel assist with duals **Serial No.*** 1RW7250RCES081485* **Tread width** rear 60.0" (1524 mm) to 128.9" (3272 mm) front 60.0" (1524 mm) to 88.0" (2235 mm) **Wheelbase** 115.2" (2925 mm) **Hydraulic control system** direct engine drive **Transmission** selective gear fixed ratio with full range operator controlled power shift **Nominal travel speeds mph (km/h)** first 1.43 (2.30) second 1.65 (2.66) third 1.91 (3.07) fourth 2.20 (3.54) fifth 2.54 (4.08) sixth 2.93 (4.71) seventh 3.35 (5.39) eighth 3.87 (6.22) ninth 4.42 (7.12) tenth 5.11 (8.22) eleventh 5.90 (9.49) twelfth 6.79 (10.92) thirteenth 7.84 (12.61) fourteenth 8.97 (14.44) fifteenth 10.36 (16.68) sixteenth 12.04 (19.37) seventeenth 13.90 (22.37) eighteenth 16.05 (25.83) nineteenth 18.54 (29.84) twentieth 21.33 (34.33) twenty-first 24.64 (39.65) twenty-second 26.10 (42.00) twenty-third 26.10 (42.00) electronically limited

POWER TAKE-OFF PERFORMANCE

| Power HP (kW) | Crank shaft speed rpm | Diesel Consumption | | D.E.F. Consumption | | Mean Atmospheric Conditions |
|---|-----------------------|--------------------|--------------------|--------------------|--------------|--|
| | | Gal/hr (l/h) | lb/hp.hr (kg/kW.h) | Hp.hr/gal (kW.h/l) | Gal/hr (l/h) | |
| Rated Engine Speed—(PTO speed—1077 rpm) | | | | | | |
| 214.51 (159.96) | 2100 | 12.19 (46.14) | 0.398 (0.242) | 17.60 (3.47) | 0.32 (1.20) | Fuel used during active exhaust regeneration-1.78 gal (6.74 l) (see note 1, p.2) |
| Standard Power Take-off Speed (1000 rpm) | | | | | | |
| 236.31 (176.21) | 1950 | 13.18 (49.91) | 0.391 (0.238) | 17.92 (3.53) | 0.37 (1.40) | |
| Maximum Power (1 hour) | | | | | | |
| 241.94 (180.41) | 1751 | 13.27 (50.22) | 0.384 (0.234) | 18.24 (3.59) | 0.39 (1.46) | |

VARYING POWER AND FUEL CONSUMPTION

| Power HP (kW) | Crank shaft speed rpm | Diesel Consumption Gal/hr (l/h) | lb/hp.hr (kg/kW.h) | Hp.hr/gal (kW.h/l) | D.E.F. Consumption Gal/hr (l/h) | Mean Atmospheric Conditions |
|-----------------|-----------------------|---------------------------------|--------------------|--------------------|---------------------------------|-----------------------------|
| 214.51 (159.96) | 2100 | 12.19 (46.14) | 0.398 (0.242) | 17.60 (3.47) | 0.32 (1.20) | Air temperature |
| 187.08 (139.50) | 2154 | 10.81 (40.94) | 0.405 (0.246) | 17.30 (3.41) | 0.29 (1.08) | 73°F (23°C) |
| 140.86 (105.04) | 2164 | 8.51 (32.21) | 0.423 (0.257) | 16.55 (3.26) | 0.26 (0.98) | Relative humidity |
| 94.33 (70.34) | 2173 | 6.45 (24.41) | 0.479 (0.291) | 14.63 (2.88) | 0.17 (0.66) | 38% |
| 47.22 (35.21) | 2184 | 4.71 (17.81) | 0.698 (0.424) | 10.04 (1.98) | 0.09 (0.34) | Barometer |
| 0.67 (0.50) | 2193 | 2.49 (9.43) | 26.125 (15.891) | 0.27 (0.05) | 0.13 (0.47) | 28.49" Hg (96.48 kPa) |

Maximum torque - 777 lb.-ft. (1054 Nm) at 1500 rpm
 Maximum torque rise - 44.9%
 Torque rise at 1680 engine rpm - 40%
 Power increase at 1751 engine rpm - 12.8%

DRAWBAR PERFORMANCE UNBALLASTED - FRONT DRIVE ENGAGED FUEL CONSUMPTION CHARACTERISTICS

| Power Hp (kW) | Drawbar pull lbs (kN) | Speed mph (km/h) | Crank-shaft speed rpm | Slip % | Fuel Consumption lb/hp.hr (kg/kW.h) | Hp.hr/gal (kW.h/l) | Temp. °F (°C) cool-ing med | Air dry bulb (°C) | Barom. inch Hg (kPa) |
|---|-----------------------|------------------|-----------------------|--------|-------------------------------------|--------------------|----------------------------|-------------------|----------------------|
| Power at Rated Engine Speed—9th Gear-Manual mode | | | | | | | | | |
| 191.17 (142.56) | 16856 (74.98) | 4.26 (6.85) | 2100 | 3.5 | 0.444 (0.270) | 15.76 (3.10) | 221 (105) | 72 (22) | 28.57 (96.75) |
| 75% of Pull at Rated Engine Speed—9th Gear-Manual mode | | | | | | | | | |
| 149.58 (111.54) | 12681 (56.41) | 4.42 (7.11) | 2159 | 2.4 | 0.451 (0.274) | 15.54 (3.06) | 220 (105) | 59 (15) | 28.03 (94.92) |
| 50% of Pull at Rated Engine Speed—9th Gear-Manual mode | | | | | | | | | |
| 101.14 (75.42) | 8458 (37.62) | 4.48 (7.21) | 2168 | 1.5 | 0.489 (0.297) | 14.32 (2.82) | 219 (104) | 58 (14) | 28.04 (94.95) |
| 75% of Pull at Reduced Engine Speed—4.6 mph (7.4 km/h)-Auto mode | | | | | | | | | |
| 149.41 (111.42) | 12554 (55.84) | 4.46 (7.18) | 1419 | 2.5 | 0.433 (0.264) | 16.16 (3.18) | 220 (104) | 58 (15) | 28.04 (94.95) |
| 50% of Pull at Reduced Engine Speed—4.6 mph (7.4 km/h)-Auto mode | | | | | | | | | |
| 101.11 (75.40) | 8423 (37.47) | 4.50 (7.24) | 1228 | 1.5 | 0.453 (0.275) | 15.48 (3.05) | 218 (103) | 58 (14) | 28.05 (94.99) |

DRAWBAR PERFORMANCE
UNBALLASTED - FRONT DRIVE ENGAGED
MANUAL MODE - 2100 ENGINE RPM
DRAWBAR POWER IN SELECTED GEARS

| Power Hp (kW) | Drawbar pull lbs (kN) | Speed mph (km/h) | Crank- shaft speed rpm | Slip % | Fuel Consumption lb/hp.hr (kg/kW.h) | Fuel Consumption Hp.hr/gal (kW.h/l) | Temp. °F (°C) cool- ing med | Air dry bulb | Barom. inch Hg (kPa) |
|---------------------|--------------------------------|------------------------|---------------------------------|-----------|---|---|--------------------------------------|--------------------|-------------------------------|
| 7th Gear | | | | | | | | | |
| 172.79 (128.85) | 22564 (100.37) | 2.88 (4.63) | 2103 | 14.1 | 0.490 (0.298) | 14.29 (2.82) | 220 (104) | 57 (14) | 28.02 (94.89) |
| 8th Gear | | | | | | | | | |
| 189.18 (141.07) | 19469 (86.60) | 3.65 (5.87) | 2100 | 5.5 | 0.447 (0.272) | 15.65 (3.08) | 221 (105) | 56 (13) | 28.03 (94.92) |
| 9th Gear | | | | | | | | | |
| 191.17 (142.56) | 16856 (74.98) | 4.26 (6.85) | 2100 | 3.5 | 0.444 (0.270) | 15.76 (3.10) | 221 (105) | 72 (22) | 28.57 (96.75) |
| 10th Gear | | | | | | | | | |
| 192.01 (143.18) | 14547 (64.71) | 4.95 (7.97) | 2100 | 2.7 | 0.441 (0.268) | 15.87 (3.13) | 221 (105) | 74 (24) | 28.56 (96.72) |
| 11th Gear | | | | | | | | | |
| 192.96 (143.89) | 12580 (55.96) | 5.75 (9.25) | 2100 | 2.3 | 0.439 (0.267) | 15.96 (3.14) | 220 (104) | 65 (18) | 28.59 (96.82) |
| 12th Gear | | | | | | | | | |
| 193.11 (144.00) | 10904 (48.50) | 6.64 (10.69) | 2099 | 1.8 | 0.439 (0.267) | 15.96 (3.14) | 220 (104) | 67 (19) | 28.59 (96.82) |
| 13th Gear | | | | | | | | | |
| 190.56 (142.10) | 9281 (41.28) | 7.70 (12.39) | 2100 | 1.4 | 0.442 (0.269) | 15.85 (3.12) | 220 (104) | 70 (21) | 28.58 (96.78) |
| 14th Gear | | | | | | | | | |
| 188.50 (140.56) | 8002 (35.59) | 8.84 (14.22) | 2101 | 1.2 | 0.447 (0.272) | 15.65 (3.08) | 221 (105) | 76 (25) | 28.54 (96.65) |

reverse 1.34 (2.15), 1.78 (2.87), 2.37 (3.81), 3.13 (5.04), 3.58 (5.76), 4.77 (7.68), 6.34 (10.21), 8.39 (13.50), 11.25 (18.11), 15.01 (24.15), 18.64 (30.00) electronically limited **Clutch** wet multiple disc hydraulically actuated by foot pedal **Brakes** wet multiple disc hydraulically operated by two foot pedals that can be locked together **Steering** hydrostatic **Power take-off** 540 rpm at 1958 engine rpm or 1000 rpm at 1950 engine rpm **Unladen tractor mass** 23400 lb (10614 kg)

REPAIRS AND ADJUSTMENTS: No repairs or adjustments.

NOTE 1: The manufacturer declares that the average time between active regenerations is 40 hours, while operated in Auto Filter Cleaning Mode, at rated speed, full load, under steady state conditions. A 2% power increase was observed during the active regeneration.

REMARKS: All test results were determined from observed data obtained in accordance with official OECD, SAE and Nebraska test procedures. This tractor fell 0.85% short of meeting the manufacturer's remote hydraulic flow claim of 59 GPM (223.3 l/min) with the 85 cc pump. The performance figures on this summary were taken from a test conducted under the OECD Code 2 test procedure.

REPORT REISSUED. Supplemental sales permit for John Deere 7R 250 Diesel, January, 2021.

We, the undersigned, certify that this is a true and correct report of official Tractor Test No. **2085A**, Nebraska Summary 934A, January 14, 2021.

Roger M. Hoy
 Director

M.F. Kocher
 P.J. Jasa
 J.D. Luck
 Board of Tractor Test Engineers

TRACTOR SOUND LEVEL WITH CAB

| | Front Wheel Drive Engaged dB(A) | Disengaged dB(A) |
|------------------------------------|---------------------------------------|---------------------|
| At no load in 9th gear | 66.9 | 66.9 |
| Transport speed-no load- 21st gear | | 69.7 |
| Bystander in 21st gear | | 83.8 |

Horizontal distance of drawbar hitch point behind rear wheel axis - 47.4"(1203 mm)

TIRES AND WEIGHT

Rear Tires - No., size, ply & psi(kPa)
Front Tires - No., size, ply & psi(kPa)
Height of Drawbar
Static Weight with operator - Rear
 - Front
 - Total

Tested Without Ballast

Four 480/80R46;***;12(85)
 Two 420/90R30;***;15(105)
 18.5 in (470 mm)
 15700 lb (7121 kg)
 7875 lb (3572 kg)
 23575 lb(10693 kg)

DRAWBAR PERFORMANCE
UNBALLASTED - FRONT DRIVE ENGAGED - AUTO MODE
(Loads based on 2100 engine rpm manual mode performance runs)
DRAWBAR POWER AT SELECTED TRAVEL SPEEDS

| Power Hp (kW) | Drawbar pull lbs (kN) | Speed mph (km/h) | Crank- shaft speed rpm | Slip % | Fuel Consumption lb/hp.hr (kg/kW.h) | Fuel Consumption Hp.hr/gal (kW.h/l) | Temp. °F(°C) cool- ing med | Air dry bulb | Barom. inch Hg (kPa) |
|---------------------|--------------------------------|------------------------|---------------------------------|-----------|---|---|-------------------------------------|--------------------|-------------------------------|
| 177.19 (132.13) | 22069 (98.17) | 3.01 (4.84) | 1588 | 9.8 | 0.446 (0.309) | 15.69 (3.09) | 220 (104) | 57 (14) | 28.02 (94.89) |
| 188.31 (140.42) | 19484 (86.67) | 3.63 (5.83) | 1581 | 5.5 | 0.427 (0.260) | 16.41 (3.23) | 221 (105) | 57 (14) | 28.04 (94.95) |
| 191.26 (142.62) | 16707 (74.31) | 4.29 (6.90) | 1589 | 3.6 | 0.424 (0.258) | 16.50 (3.25) | 220 (104) | 73 (23) | 28.56 (96.72) |
| 191.73 (142.97) | 14596 (64.93) | 4.93 (7.93) | 1573 | 2.8 | 0.422 (0.257) | 16.60 (3.27) | 221 (105) | 75 (24) | 28.55 (96.68) |
| 192.09 (143.24) | 12412 (55.21) | 5.80 (9.33) | 1593 | 2.3 | 0.420 (0.255) | 16.68 (3.29) | 219 (104) | 69 (21) | 28.58 (96.78) |
| 193.22 (144.08) | 10854 (48.28) | 6.68 (10.75) | 1596 | 1.8 | 0.419 (0.255) | 16.71 (3.29) | 219 (104) | 68 (20) | 28.59 (96.82) |
| 190.23 (141.85) | 9150 (40.70) | 7.80 (12.55) | 1608 | 1.4 | 0.420 (0.256) | 16.66 (3.28) | 220 (104) | 70 (21) | 28.58 (96.78) |
| 189.11 (141.02) | 7929 (35.27) | 8.94 (14.39) | 1585 | 1.2 | 0.424 (0.258) | 16.50 (3.25) | 221 (105) | 76 (25) | 28.54 (96.65) |

DRAWBAR PERFORMANCE
UNBALLASTED - FRONT DRIVE ENGAGED - 1750 ENGINE RPM
MAXIMUM POWER IN SELECTED GEARS

| Power Hp (kW) | Drawbar pull lbs (kN) | Speed mph (km/h) | Crank- shaft speed rpm | Slip % | Fuel Consumption lb/hp.hr (kg/kW.h) | Consumption Hp.hr/gal (kW.h/l) | Temp. °F(°C) cool- ing med | Air dry bulb | Barom. inch Hg (kPa) |
|---------------------|--------------------------------|------------------------|---------------------------------|-----------|---|--------------------------------------|-------------------------------------|--------------------|-------------------------------|
| 7th Gear | | | | | | | | | |
| 173.15 (129.11) | 22622 (100.63) | 2.87 (4.62) | 2102 | 14.2 | 0.490 (0.298) | 14.28 (2.81) | 220 (104) | 56 (13) | 28.01 (94.85) |
| 8th Gear | | | | | | | | | |
| 196.42 (146.47) | 21500 (95.64) | 3.43 (5.51) | 2025 | 7.9 | 0.456 (0.277) | 15.37 (3.03) | 221 (105) | 57 (14) | 28.04 (94.95) |
| 9th Gear | | | | | | | | | |
| 206.58 (154.05) | 20667 (91.93) | 3.75 (6.04) | 1918 | 6.9 | 0.446 (0.271) | 15.70 (3.09) | 220 (104) | 59 (15) | 28.04 (94.95) |
| 10th Gear | | | | | | | | | |
| 212.76 (158.66) | 19591 (87.15) | 4.08 (6.56) | 1784 | 5.8 | 0.433 (0.263) | 16.17 (3.18) | 221 (105) | 59 (15) | 28.02 (94.89) |
| 11th Gear | | | | | | | | | |
| 215.91 (161.00) | 17241 (76.69) | 4.70 (7.56) | 1750 | 4.1 | 0.429 (0.261) | 16.34 (3.22) | 221 (105) | 60 (16) | 28.03 (94.92) |
| 12th Gear | | | | | | | | | |
| 218.41 (162.87) | 15003 (66.73) | 5.46 (8.79) | 1750 | 3.2 | 0.423 (0.257) | 16.57 (3.26) | 222 (106) | 61 (16) | 28.03 (94.92) |
| 13th Gear | | | | | | | | | |
| 218.15 (162.67) | 12893 (57.35) | 6.35 (10.21) | 1749 | 2.6 | 0.421 (0.256) | 16.65 (3.28) | 222 (106) | 60 (15) | 28.03 (94.92) |
| 14th Gear | | | | | | | | | |
| 217.49 (162.18) | 11182 (49.74) | 7.29 (11.73) | 1750 | 2.1 | 0.421 (0.256) | 16.62 (3.27) | 222 (106) | 61 (16) | 28.03 (94.92) |
| 15th Gear | | | | | | | | | |
| 215.55 (160.74) | 9556 (42.51) | 8.46 (13.62) | 1750 | 1.7 | 0.425 (0.258) | 16.48 (3.25) | 222 (106) | 60 (16) | 28.03 (94.92) |

HYDRAULIC PERFORMANCE

CATEGORY: III

Quick Attach: Yes

OECD Static test

Maximum force exerted through whole range: lift cylinders
 15862 lbs (70.6 kN) (2x100 mm)
 18302 lbs (81.4 kN) (1x100 mm & 1x115 mm)

i) Sustained pressure at compensator cutoff: 63 cc pump 85 cc pump
 2953 psi (204 bar) 2887 psi (199 bar)
three outlet sets combined

ii) Pump delivery rate at minimum pressure and rated engine speed: 45.2 GPM (170.9 l/min) 58.5 GPM (221.4 l/min)

iii) Pump delivery rate at maximum hydraulic power: 44.3 GPM (167.9 l/min) 58.3 GPM (220.7 l/min)
 Delivery pressure: 2867 psi (198 bar) 2773 psi (191 bar)
 Power: 74.2 HP (55.3 kW) 94.3 HP (70.3 kW)

ii) Pump delivery rate at minimum pressure and rated engine speed: 36.0 GPM (136.2 l/min) 36.5 GPM (138.1 l/min)

iii) Pump delivery rate at maximum hydraulic power: 35.5 GPM (134.4 l/min) 34.2 GPM (129.5 l/min)
 Delivery pressure: 2803 psi (193 bar) 2291 psi (158 bar)
 Power: 58.1 HP (43.3 kW) 45.7 HP (34.1 kW)

HITCH DIMENSIONS AS TESTED—NO LOAD

| | inch | mm |
|-----|------|------|
| A | 28.0 | 710 |
| B | 20.5 | 520 |
| C | 22.9 | 581 |
| D | 18.9 | 480 |
| E | 7.3 | 185 |
| F | 14.4 | 365 |
| G | 38.8 | 985 |
| H | 3.5 | 90 |
| I | 22.4 | 570 |
| J | 24.4 | 620 |
| K | 29.3 | 745 |
| L | 52.0 | 1321 |
| *L' | 56.0 | 1423 |
| M | 28.0 | 712 |
| N | 43.4 | 1102 |
| O | 9.0 | 230 |
| P | 51.9 | 1319 |
| Q | 39.4 | 1001 |
| R | 44.9 | 1140 |

*L' to Quick Attach ends

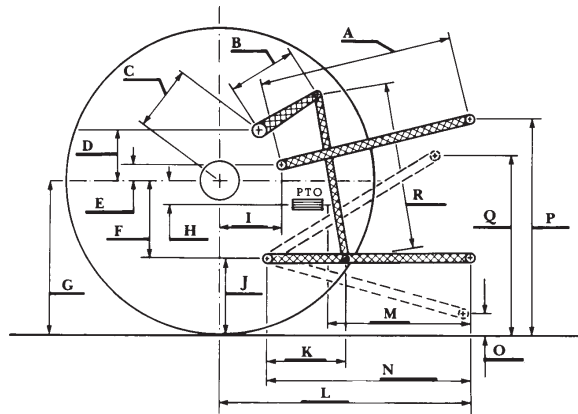

RECOMMENDED CITATION FORMAT:

NTTL.(2021). Nebraska OECD tractor test 2085A for John Deere 7R 250 e23 Diesel. Lincoln, NE:Nebraska Tractor Test Laboratory. Retrieved from <http://tractortestlab.unl.edu>



JOHN DEERE 7R 250 DIESEL

Institute of Agriculture and Natural Resources
 University of Nebraska–Lincoln