

University of Nebraska - Lincoln

DigitalCommons@University of Nebraska - Lincoln

Nebraska Tractor Tests

Tractor Test and Power Museum, The Lester F.
Larsen

2021

Test 2229: CIAAS Xerion 5000 T5

Nebraska Tractor Test Lab

Follow this and additional works at: <https://digitalcommons.unl.edu/tractormuseumlit>



Part of the [Energy Systems Commons](#), [History of Science, Technology, and Medicine Commons](#), [Other Mechanical Engineering Commons](#), [Physical Sciences and Mathematics Commons](#), [Science and Mathematics Education Commons](#), and [the United States History Commons](#)

This Article is brought to you for free and open access by the Tractor Test and Power Museum, The Lester F. Larsen at DigitalCommons@University of Nebraska - Lincoln. It has been accepted for inclusion in Nebraska Tractor Tests by an authorized administrator of DigitalCommons@University of Nebraska - Lincoln.

NEBRASKA OECD TRACTOR TEST 2229 - SUMMARY 1176

CLAAS XERION 5000 DIESEL

CONTINUOUSLY VARIABLE TRANSMISSION

Chassis Serial numbers 784 00011 and higher

POWER TAKE-OFF PERFORMANCE

Power HP (kW)	Crank shaft speed rpm	Diesel Consumption		D.E.F. Consumption		Mean Atmospheric Conditions
		Gal/hr (l/h)	lb/hp.hr (kg/kW.h)	Hp.hr/gal (kW.h/l)	Gal/hr (l/h)	
MAXIMUM POWER AND FUEL CONSUMPTION						
Rated Engine Speed—(PTO speed—1098 rpm)						
453.74 (338.35)	1899	23.85 (90.28)	0.367 (0.223)	19.03 (3.75)	0.67 (2.54)	
Standard Power Take-off Speed (1000 rpm)						
482.49 (359.79)	1729	24.47 (92.64)	0.354 (0.215)	19.71 (3.88)	0.58 (2.21)	
Maximum Power (1 hour)						
487.14 (363.26)	1599	24.55 (92.93)	0.352 (0.214)	19.84 (3.91)	0.59 (2.24)	

VARYING POWER AND FUEL CONSUMPTION

453.74 (338.35)	1899	23.85 (90.28)	0.367 (0.223)	19.03 (3.75)	0.67 (2.54)	Air temperature
387.04 (288.61)	1902	20.37 (77.10)	0.367 (0.223)	19.00 (3.74)	0.84 (3.17)	73°F (23°C)
289.93 (216.20)	1906	16.08 (60.87)	0.387 (0.236)	18.03 (3.55)	0.72 (2.74)	Relative humidity
193.60 (144.37)	1909	11.93 (45.17)	0.430 (0.262)	16.22 (3.20)	0.62 (2.35)	42%
97.48 (72.69)	1913	7.82 (29.60)	0.560 (0.341)	12.47 (2.46)	0.47 (1.78)	Barometer
1.19 (0.89)	1916	3.91 (14.80)	22.858 (13.904)	0.31 (0.06)	0.28 (1.07)	28.30" Hg (95.83 kPa)

Maximum torque - 1798 lb.-ft. (2438 Nm) at 1100 rpm

Maximum torque rise - 43.3%

Torque rise at 1521 engine rpm - 33%

Power increase at 1599 engine rpm - 7.4%

DRAWBAR PERFORMANCE

FUEL CONSUMPTION CHARACTERISTICS

Power Hp (kW)	Drawbar pull lbs (kN)	Speed mph (km/h)	Crank- shaft speed rpm	Slip %	Fuel Consumption lb/hp.hr (kg/kW.h)	D.E.F. Consumption Hp.hr/gal (kW.h/l)	Temp. °F(°C) cool- ing med	Air dry bulb	Barom. inch Hg (kPa)	
Power at Rated Engine Speed—4.7 mph (7.5 km/h)-Manual mode										
409.01 (305.00)	36683 (163.17)	4.18 (6.73)	1841	5.4	0.409 (0.249)	17.05 (3.36)	0.014 (0.008)	194 (90)	51 (10)	28.73 (97.29)
75% of Pull at Rated Engine Speed—4.7 mph (7.5 km/h)-Manual mode										
311.85 (232.54)	27516 (122.40)	4.25 (6.84)	1860	3.6	0.413 (0.251)	16.92 (3.33)	0.023 (0.014)	197 (92)	70 (21)	28.91 (97.90)
50% of Pull at Rated Engine Speed—4.7 mph (7.5 km/h)-Manual mode										
211.37 (157.61)	18346 (81.60)	4.32 (6.95)	1876	2.3	0.449 (0.273)	15.56 (3.07)	0.031 (0.019)	195 (91)	71 (22)	28.91 (97.90)
75% of Pull at Reduced Engine Speed—4.7 mph (7.5 km/h)-Auto mode										
311.90 (232.58)	27743 (123.40)	4.22 (6.78)	1219	3.5	0.393 (0.239)	17.75 (3.50)	0.027 (0.016)	197 (91)	72 (22)	28.90 (97.87)
50% of Pull at Reduced Engine Speed—4.7 mph (7.5 km/h)-Auto mode										
209.88 (156.50)	18128 (80.64)	4.34 (6.98)	1115	2.3	0.394 (0.239)	17.74 (3.49)	0.031 (0.019)	198 (925)	73 (23)	28.89 (97.83)

Location of tests: Nebraska Tractor Test Laboratory, University of Nebraska, Lincoln, Nebraska 68583-0832

Dates of tests: November 3, 2020 to March 23, 2021

Manufacturer: CLAAS Selbstfahrende Erntemaschinen GmbH, 33428 Harsewinkel, Germany

CONSUMABLE Fluids, OIL and TIME: Fuel No. 2 Diesel **Specific gravity converted to 60°/60°F (15°/15°C)** 0.8386 **Fuel weight** 6.982 lbs/gal (0.837 kg/l) **Diesel Exhaust Fluid (DEF)** 32% aqueous urea solution **DEF weight** 9.071 lbs/gal (1.087 kg/l) **Oil SAE 10W40 API service classification** CK-4 **Transmission lubricant** Agrishift XE fluid **Hydraulics, front and rear axle lubricant** Claas Agrihyd HVLDPD fluid **Final drive lubricant** MT 80W-90 API GL 5 **Total time engine was operated:** 28.5 hours

ENGINE: Make Mercedes-Benz Diesel **Type** six cylinder vertical with turbocharger, air to air intercooler and D.E.F. (diesel exhaust fluid) exhaust treatment **Serial No.** 471.945-C-0561126 **Crankshaft** lengthwise **Rated engine speed** 1900 **Bore and stroke** 5.197" x 6.142" (132.0 mm x 156.0 mm) **Compression ratio** 17.3 to 1 **Displacement** 781 cu in (12810 ml) **Starting system** 24 volt **Lubrication** pressure **Air cleaner** two paper elements and aspirator **Oil filter** one full flow cartridge **Oil cooler** engine coolant heat exchanger for crankcase oil, separate radiators for hydraulic, transmission, front axle and rear axle oils **Fuel filter** two paper elements **Exhaust** DOC (diesel oxidation catalyst)/DPF (diesel particulate filter) and SCR (selective catalyst reduction) within a horizontal muffler with vertical outlet **Cooling medium temperature control** thermostat and variable speed fan

ENGINE OPERATING PARAMETERS: Fuel rate: 166.4 - 173.1 lb/h (75.5 - 78.5 kg/h) **High idle:** 1910 - 1930 rpm (Drawbar operations - 1850 - 1890 rpm) **Turbo boost:** nominal 31.9 - 34.8 psi (220 - 240 kPa) as measured 32.0 psi (221 kPa)

CHASSIS: Type rigid frame four wheel drive with duals **Serial No.** *78400071* **Tread width** rear 89.2" (2265 mm) and 159.8" (4060 mm) front 89.2" (2265 mm) and 159.8" (4060 mm) **Wheelbase** 141.7" (3600 mm) **Hydraulic control system** direct engine drive **Transmission** Infinitely variable with four mechanical ranges and automatic shifting between ranges **Nominal travel speeds mph (km/h)** forward - 0 - 31 mph, (0 - 50 km/h) reverse - 0 - 31 mph (0 - 50 km/h) **Clutch** a foot pedal controls the hydrostatic oil flow **Brakes** wet disc hydraulically operated by foot pedal **Steering** electro-hydraulic with the ability to steer front and rear axles independently or coordinated

**DRAWBAR PERFORMANCE AT
1840 ENGINE RPM-MANUAL MODE
DRAWBAR POWER AT SELECTED TRAVEL SPEEDS**

Power Hp (kW)	Drawbar pull lbs (kN)	Speed mph (km/h)	Crank- shaft speed rpm	Slip %	Fuel Consumption lb/hp.hr (kg/kW.h)	D.E.F. Consumption Hp.hr/gal (kW.h/l)	Temp. °F(°C) cool- ing med	Air dry bulb	Barom. inch Hg (kPa)	
3.1 mph (5.0 km/h)										
295.78 (220.56)	43069 (191.58)	2.58 (4.15)	1855	12.1	0.472 (0.287)	14.80 (2.92)	0.025 (0.015)	199 (93)	44 (7)	28.91 (97.88)
3.7 mph (6.0 km/h)										
361.06 (269.24)	42093 (187.24)	3.22 (5.18)	1846	9.6	0.442 (0.269)	15.78 (3.11)	0.018 (0.011)	198 (92)	50 (10)	28.91 (97.90)
4.2 mph (6.8 km/h)										
393.76 (293.62)	39688 (176.54)	3.72 (5.99)	1842	6.4	0.422 (0.257)	16.53 (3.26)	0.015 (0.009)	197 (91)	53 (12)	28.90 (97.87)
4.7 mph (7.5 km/h)										
409.01 (305.00)	36683 (163.17)	4.18 (6.73)	1841	5.4	0.409 (0.249)	17.05 (3.36)	0.014 (0.008)	194 (90)	51 (10)	28.73 (97.29)
5.1 mph (8.2 km/h)										
408.29 (304.46)	33171 (147.55)	4.62 (7.43)	1841	4.3	0.410 (0.250)	17.02 (3.35)	0.014 (0.008)	198 (92)	51 (11)	28.73 (97.29)
5.6 mph (9.0 km/h)										
404.74 (301.81)	29841 (132.74)	5.09 (8.19)	1842	3.5	0.412 (0.251)	16.93 (3.34)	0.013 (0.008)	199 (93)	52 (11)	28.73 (97.29)
6.2 mph (10.0 km/h)										
400.62 (298.74)	26885 (119.59)	5.59 (9.00)	1841	3.2	0.416 (0.253)	16.79 (3.31)	0.013 (0.008)	197 (92)	60 (16)	28.73 (97.29)
6.8 mph (11.0 km/h)										
397.74 (296.59)	23754 (105.66)	6.28 (10.11)	1841	2.6	0.418 (0.254)	16.70 (3.29)	0.014 (0.008)	198 (92)	62 (16)	28.73 (97.29)
7.5 mph (12.0 km/h)										
405.58 (302.44)	22011 (97.91)	6.91 (11.12)	1841	2.3	0.410 (0.250)	17.01 (3.35)	0.013 (0.008)	198 (92)	64 (18)	28.72 (97.26)
8.1 mph (13.0 km/h)										
405.13 (302.10)	20284 (90.23)	7.49 (12.05)	1839	2.1	0.415 (0.253)	16.81 (3.31)	0.013 (0.008)	200 (93)	68 (20)	28.73 (97.29)
8.7 mph (14.0 km/h)										
407.65 (303.98)	18938 (84.24)	8.08 (13.00)	1842	1.9	0.411 (0.250)	16.99 (3.35)	0.014 (0.009)	200 (93)	68 (20)	28.72 (97.26)

Power take-off 1000 rpm at 1730 engine rpm
Unladen tractor mass 42175 lb (19130 kg)

REPAIRS AND ADJUSTMENTS: No repairs or adjustments.

NOTE 1: To facilitate drawbar testing, the tractor was equipped with computer software that locked the transmission into the speed settings shown. These runs are denoted as Manual mode.

NOTE 2: The performance data on this report applies to tractors with chassis serial numbers 784 00011 and higher.

REMARKS: All test results were determined from observed data obtained in accordance with official OECD, SAE and Nebraska test procedures. This tractor fell 3.3% short of meeting the manufacturer's 3 point lift claim of 22480 lb (100 kN) and 1% short of the remote hydraulic flow claim of 51.5 GPM (195 l/min) with standard pump. The manufacturer's remote hydraulic flow claim of 72.5 GPM (275 l/min) with "twin priority" pump was not verified. This tractor exceeded the 67 dB(A) sound power claim by 31.8% (1.2 dB(A)). The performance figures on this Summary were taken from a test conducted under the OECD Code 2 test procedure.

We, the undersigned, certify that this is a true and correct report of official Tractor Test No. **2229**, Nebraska Summary 1176, May 4, 2021.

Roger M. Hoy
Director

M.F. Kocher
P.J. Jasa
J.D. Luck
Board of Tractor Test Engineers

TRACTOR SOUND LEVEL WITH CAB	dB(A)
At no load at 4.7 mph (7.5 km/h) engine speed 1910 rpm	68.2
At no load at 4.7 mph (7.5 km/h) engine speed 1140 rpm	65.5
Bystander	90.5

Horizontal distance of drawbar hitch point behind rear wheel axis - 43.5" (1105 mm), 49.4" (1255 mm), 55.3" (1405 mm)

TIRES AND WEIGHT

Rear Tires - No., size, ply & psi (kPa)
Front Tires - No., size, ply & psi (kPa)
Height of Drawbar
Static Weight with operator - Rear
- Front
- Total

Tested Without Ballast

Four 710/70R42;***;8(55)
Four 710/70R42;***;8(55)
20.5 in (520 mm)
18795 lb (8525 kg)
23555 lb (10685 kg)
42350 lb (19210 kg)

DRAWBAR PERFORMANCE - AUTO MODE

(Loads based on 1840 engine rpm manual mode performance runs)
DRAWBAR POWER AT SELECTED TRAVEL SPEEDS

Power Hp (kW)	Drawbar pull lbs (kN)	Speed mph (km/h)	Crank- shaft speed rpm	Slip %	Fuel Consumption lb/hp.hr (kg/kW.h)	Consumption Hp.hr/gal (kW.h/l)	D.E.F. Consumption lb/hp.hr (kg/kW.h)	Temp. °F(°C) cool- ing med	Air dry bulb	Barom. inch Hg (kPa)
4.7 mph (7.6 km/h)										
408.57 (304.67)	36678 (163.15)	4.18 (6.72)	1514	5.4	0.409 (0.249)	17.07 (3.36)	0.012 (0.007)	193 (89)	55 (13)	28.73 (97.29)
5.2 mph (8.3 km/h)										
405.67 (302.51)	33064 (147.07)	4.60 (7.40)	1559	4.4	0.407 (0.248)	17.15 (3.38)	0.014 (0.008)	195 (91)	57 (14)	28.73 (97.29)
5.7 mph (9.2 km/h)										
404.30 (301.48)	29832 (132.70)	5.09 (8.18)	1793	3.5	0.412 (0.251)	16.94 (3.34)	0.014 (0.008)	197 (92)	58 (14)	28.73 (97.29)
6.4 mph (10.3 km/h)										
401.05 (299.06)	26911 (119.71)	5.59 (9.00)	1648	3.2	0.414 (0.252)	16.86 (3.32)	0.013 (0.008)	197 (92)	64 (18)	28.73 (97.29)
7.0 mph (11.3 km/h)										
399.51 (297.91)	23598 (104.97)	6.35 (10.22)	1767	2.6	0.410 (0.249)	17.04 (3.36)	0.014 (0.009)	198 (92)	64 (18)	28.73 (97.29)
7.6 mph (12.3 km/h)										
404.99 (302.00)	21861 (97.24)	6.95 (11.18)	1402	2.3	0.389 (0.237)	17.94 (3.53)	0.014 (0.009)	196 (91)	65 (18)	28.73 (97.29)
8.3 mph (13.4 km/h)										
407.41 (303.80)	20092 (89.37)	7.61 (12.24)	1409	2.1	0.389 (0.237)	17.94 (3.53)	0.013 (0.008)	198 (92)	69 (21)	28.72 (97.26)
8.9 mph (14.4 km/h)										
407.84 (304.12)	18871 (83.94)	8.11 (13.04)	1696	2.0	0.399 (0.243)	17.51 (3.45)	0.014 (0.008)	199 (93)	69 (21)	28.72 (97.26)

**DRAWBAR PERFORMANCE AT
1600 ENGINE RPM-MANUAL MODE-UNBALLASTED
MAXIMUM POWER AT SELECTED TRAVEL SPEEDS**

Power Hp (kW)	Drawbar pull lbs (kN)	Speed mph (km/h)	Crank- shaft speed rpm	Slip %	Fuel Consumption lb/hp.hr (kg/kW.h)	Hp.hr/gal (kW.h/l)	D.E.F. Consumption lb/hp.hr (kg/kW.h)	Temp. °F(°C) cool- ing med	Air dry bulb	Barom. inch Hg (kPa)
3.1 mph (5.0 km/h)										
301.00 (224.46)	43052 (191.50)	2.62 (4.22)	1855	10.4	0.462 (0.281)	15.10 (2.97)	0.023 (0.014)	197 (92)	43 (6)	28.90 (97.87)
3.7 mph (6.0 km/h)										
361.63 (269.67)	42160 (187.53)	3.22 (5.18)	1846	9.6	0.442 (0.269)	15.78 (3.11)	0.017 (0.010)	199 (93)	50 (10)	28.91 (97.90)
4.2 mph (6.8 km/h)										
399.20 (297.68)	40937 (182.09)	3.66 (5.89)	1815	7.5	0.425 (0.259)	16.42 (3.24)	0.014 (0.008)	195 (90)	54 (12)	28.91 (97.90)
4.7 mph (7.5 km/h)										
410.18 (305.87)	40399 (179.70)	3.81 (6.13)	1730	7.2	0.411 (0.250)	16.99 (3.35)	0.014 (0.009)	195 (90)	55 (13)	28.91 (97.90)
5.1 mph (8.2 km/h)										
412.15 (307.34)	38572 (171.58)	4.01 (6.45)	1663	6.2	0.410 (0.249)	17.03 (3.35)	0.013 (0.008)	195 (91)	59 (15)	28.92 (97.93)
5.6 mph (9.0 km/h)										
415.87 (310.11)	35662 (158.63)	4.38 (7.04)	1600	5.3	0.409 (0.249)	17.07 (3.36)	0.012 (0.007)	198 (92)	61 (16)	28.92 (97.93)
6.2 mph (10.0 km/h)										
411.63 (306.95)	31401 (139.68)	4.92 (7.91)	1600	4.8	0.414 (0.252)	16.86 (3.32)	0.012 (0.007)	199 (93)	62 (17)	28.92 (97.93)
6.8 mph (11.0 km/h)										
403.48 (300.87)	28500 (126.77)	5.31 (8.55)	1600	3.7	0.420 (0.255)	16.62 (3.27)	0.012 (0.007)	198 (92)	64 (18)	28.92 (97.93)
7.5 mph (12.0 km/h)										
418.69 (312.22)	26119 (116.18)	6.01 (9.67)	1600	3.3	0.406 (0.247)	17.19 (3.39)	0.012 (0.007)	199 (93)	64 (18)	28.92 (97.93)
8.1 mph (13.0 km/h)										
427.29 (318.63)	23528 (104.66)	6.81 (10.96)	1601	2.6	0.398 (0.242)	17.53 (3.45)	0.011 (0.007)	200 (93)	65 (18)	28.92 (97.93)
8.7 mph (14.0 km/h)										
429.09 (319.97)	22748 (101.19)	7.08 (11.39)	1599	2.5	0.394 (0.240)	17.71 (3.49)	0.012 (0.007)	199 (93)	66 (19)	28.92 (97.93)
9.3 mph (15.0 km/h)										
428.50 (319.53)	21038 (93.58)	7.64 (12.29)	1599	2.4	0.396 (0.241)	17.65 (3.48)	0.012 (0.007)	200 (93)	67 (19)	28.92 (97.93)
9.9 mph (16.0 km/h)										
427.52 (318.80)	18925 (84.18)	8.47 (13.63)	1600	2.1	0.396 (0.241)	17.62 (3.47)	0.012 (0.007)	200 (93)	69 (21)	28.91 (97.90)

Lugging ability from speed setting 8.1 mph (13.0 km/h)

Crankshaft speed rpm	1842	1700	1650	1601	1500	1400	1300	1100
Pull-lbs (kN)	20599 (91.63)	22333 (99.34)	23344 (103.34)	24347 (108.84)	25915 (115.27)	26945 (119.86)	27255 (121.23)	27748 (123.43)
Increase in pull%	0	8	13	18	26	31	32	35
Power-Hp (kW)	407.19 (303.64)	413.55 (308.38)	418.81 (312.31)	423.22 (315.59)	421.06 (313.98)	406.98 (303.98)	380.49 (283.73)	321.95 (240.07)
Speed-mpH (km/h)	7.42 (11.93)	6.95 (11.18)	6.73 (10.83)	6.52 (10.49)	6.10 (9.81)	5.66 (9.11)	5.24 (8.42)	4.35 (7.00)
Slip %	2.2	2.4	2.5	2.7	2.9	3.3	3.5	3.6

HYDRAULIC PERFORMANCE

CATEGORY: IVN	
Quick Attach: yes	
OECD Static test	
Maximum force exerted through whole range:	21739 lbs (96.7 kN)
<u>Two outlet sets combined</u>	
<u>Standard pump</u>	
i) Sustained pressure of the open relief valve:	2796 psi (193 bar)
ii) Pump delivery rate at minimum pressure and rated engine speed:	51.0 GPM (192.9 l/min)
iii) Pump delivery rate at maximum hydraulic power:	48.1 GPM (182.2 l/min)
Delivery pressure:	2551 psi (176 bar)
Power:	71.6 HP (53.4 kW)
<u>Single outlet set</u>	
ii) Pump delivery rate at minimum pressure and rated engine speed:	32.6 GPM (123.4 l/min)
iii) Pump delivery rate at maximum hydraulic power:	31.0 GPM (117.5 l/min)
Delivery pressure:	2424 psi (167 bar)
Power:	43.9 HP (32.7 kW)

HITCH DIMENSIONS AS TESTED - NO LOAD

	inch	mm
A	31.9	810
B	23.6	600
C	19.2	487
D	18.8	478
E	11.0	279
F	16.6	422
G	37.6	955
H	0.2	5
I	25.5	647
J	21.0	533
K	22.8	578
L	57.4	1458
*L'	63.7	1618
M	30.4	773
N	41.9	1065
O	9.1	230
P	49.0	1244
Q	38.6	980
R	44.1	1120

*L' to Quick Attach ends

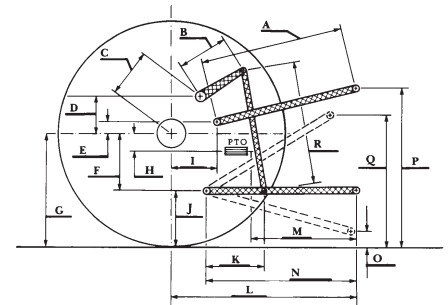

RECOMMENDED CITATION FORMAT:

NTTL.(2021). Nebraska OECD tractor test 2229 for Claas Xerion 5000 Diesel. Lincoln, NE:Nebraska Tractor Test Laboratory. Retrieved from <http://tractortestlab.unl.edu>

