

University of Nebraska - Lincoln

DigitalCommons@University of Nebraska - Lincoln

Nebraska Tractor Tests

Tractor Test and Power Museum, The Lester F.
Larsen

2021

Nebraska Summary 1215S: FENT 314 VARIO GEN4

Nebraska Tractor Test Lab

Follow this and additional works at: <https://digitalcommons.unl.edu/tractormuseumlit>



Part of the [Energy Systems Commons](#), [History of Science, Technology, and Medicine Commons](#), [Other Mechanical Engineering Commons](#), [Physical Sciences and Mathematics Commons](#), [Science and Mathematics Education Commons](#), and [the United States History Commons](#)

This Article is brought to you for free and open access by the Tractor Test and Power Museum, The Lester F. Larsen at DigitalCommons@University of Nebraska - Lincoln. It has been accepted for inclusion in Nebraska Tractor Tests by an authorized administrator of DigitalCommons@University of Nebraska - Lincoln.

SUMMARY OF OECD TEST 3298 - NEBRASKA SUMMARY 1215 FENDT 314 VARIO GEN4 DIESEL

POWER TAKE-OFF PERFORMANCE

Power HP (kW)	Crank shaft speed rpm	Diesel Consumption		D.E.F. Consumption		Mean Atmospheric Conditions
		Gal/hr (l/h)	lb/hp.hr (kg/kW.h)	Hp.hr/gal (kW.h/l)	Gal/hr (l/h)	
MAXIMUM POWER AND FUEL CONSUMPTION						
Rated Engine Speed—(PTO speed—1115 rpm)						
123.5 (92.1)	2100	7.42 (28.08)	0.416 (0.253)	16.65 (3.28)	0.50 (1.91)	
Standard Power Take-off Speed (1000 rpm)						
134.1 (101.0)	1884	7.75 (29.35)	0.396 (0.241)	17.46 (3.44)	0.50 (1.88)	
Maximum Power (1 hour)						
137.1 (102.2)	1700	7.61 (28.81)	0.385 (0.234)	18.02 (3.55)	0.52 (1.98)	

VARYING POWER AND FUEL CONSUMPTION

123.5 (92.1)	2100	7.42 (28.08)	0.416 (0.253)	16.65 (3.28)	0.50 (1.91)	Air temperature
106.1 (79.1)	2122	6.51 (24.65)	0.424 (0.258)	16.29 (3.21)	0.35 (1.33)	70°F (21°C)
80.2 (59.8)	2141	5.18 (19.61)	0.447 (0.272)	15.48 (3.05)	0.30 (1.15)	Relative humidity
53.9 (40.2)	2157	3.89 (14.73)	0.498 (0.303)	13.86 (2.73)	0.21 (0.81)	56%
27.2 (20.3)	2179	2.67 (10.10)	0.677 (0.412)	10.20 (2.01)	0.13 (0.51)	Barometer
--	2205	1.61 (6.10)	--	--	0.06 (0.24)	30.0" Hg (101.7 kPa)

Maximum torque - 441 lb.-ft. (598 Nm) at 1600 rpm
 Maximum torque rise - 42.9%
 Torque rise at 1700 engine rpm - 37%
 Power increase at 1700 engine rpm - 11.1%

DRAWBAR PERFORMANCE UNBALLASTED - FRONT DRIVE ENGAGED FUEL CONSUMPTION CHARACTERISTICS

Power Hp (kW)	Drawbar pull lbs (kN)	Speed mph (km/h)	Crank- shaft speed rpm	Slip %	Fuel Consumption		D.E.F.		Temp. °F(°C)	Barom. inch Hg (kPa)
					lb/hp.hr (kg/kW.h)	Hp.hr/gal (kW.h/l)	lb/hp.hr (kg/kW.h)	cool- ing med		
Power at Rated Engine Speed—Speed setting 9										
102.2 (76.2)	6905 (30.72)	5.55 (8.92)	2097	1.7	0.480 (0.292)	14.21 (2.80)	0.038 (0.023)	189 (87)	73 (23)	29.4 (99.7)
75% of Pull at Rated Engine Speed—Speed setting 9										
78.9 (58.8)	5170 (22.99)	5.72 (9.21)	2132	1.1	0.505 (0.307)	13.50 (2.66)	0.051 (0.031)	189 (87)	73 (23)	29.5 (99.8)
50% of Pull at Rated Engine Speed—Speed setting 9										
53.8 (40.1)	3415 (15.19)	5.91 (9.50)	2152	0.6	0.559 (0.340)	12.23 (2.41)	0.043 (0.026)	187 (86)	75 (24)	29.4 (99.7)
75% of Pull at Reduced Engine Speed—Speed setting 11										
79.0 (58.9)	5155 (22.93)	5.75 (9.25)	1759	1.1	0.457 (0.278)	14.92 (2.94)	0.035 (0.021)	183 (84)	75 (24)	29.4 (99.7)
50% of Pull at Reduced Engine Speed—Speed setting 11										
53.9 (40.2)	3430 (15.26)	5.88 (9.47)	1775	0.5	0.495 (0.301)	13.81 (2.72)	0.033 (0.020)	185 (85)	75 (24)	29.4 (99.7)

Location of tests: DLG TestService, GmbH, Max-Eyth-Weg 1, D-64823 Gross-Umstadt, Germany

Dates of tests: August to September, 2021

Manufacturer: AGCO GmbH Johann Georg Fendt Str 4 D-87616 Marktobendorf, Germany

CONSUMABLE Fluids: **Fuel** No. 2 Diesel **Specific gravity converted to 60°/60°F (15°/15°C)** 0.8303 **Fuel weight** 6.93 lbs/gal (0.829 kg/l) **Diesel Exhaust Fluid (DEF)** 32% aqueous urea solution **DEF weight** 9.071 lbs/gal (1.087 kg/l) **Oil** SAE 10W-40 **API service classification** CJ-4 **Transmission and hydraulic lubricant** Extra Trans/STOU fluid **Front axle lubricant** Extra Trans/STOU fluid

ENGINE: **Make** AGCO **Power Diesel Type** four cylinder vertical with turbocharger, air to air intercooler and D.E.F. (diesel exhaust fluid) exhaust treatment **Serial No.** MLD051015 **Crankshaft** lengthwise **Rated engine speed** 2100 **Bore and stroke** 4.251" x 4.724" (108.0 mm x 120.0 mm) **Compression ratio** 17.4 to 1 **Displacement** 268 cu in (4400 ml) **Starting system** 12 volt **Lubrication** pressure **Air cleaner** two paper elements and aspirator **Oil filter** one full flow cartridge **Oil cooler** engine coolant heat exchanger for crankcase oil, radiator for hydraulic and transmission oil **Fuel filter** one paper element and prestrainer **Fuel cooler** radiator for pump return fuel **Exhaust** DOC (diesel oxidation catalyst)/DPF (diesel particulate filter) System and SCR (selective catalyst reduction) with a vertical muffler **Cooling medium temperature control** thermostat and variable speed fan

CHASSIS: **Type** front wheel assist **Serial No.** WAM35421L00F01681 **Tread width** rear 59.1" (1500 mm) to 70.9" (1800 mm) front 59.1" (1500 mm) to 71.7" (1820 mm) **Wheelbase** 95.3" (2420 mm) **Hydraulic control system** direct engine drive **Transmission** Fendt Vario. A combination of mechanical and hydrostatic sections allow an infinite speed adjustment within the ranges noted. **Nominal travel speeds mph (km/h)** forward: 0-25 (0-40) reverse: 0-15 (0-25) **Clutch** a foot pedal controls the hydrostatic oil flow **Brakes** wet multiple disc hydraulically operated by two foot pedals that can be locked together **Steering** hydrostatic **Power take-off** 540 rpm at 1910 engine rpm or 1000 rpm at 1884 engine rpm **Unladen tractor mass** 12810 lb (5810 kg)

DRAWBAR PERFORMANCE

UNBALLASTED - FRONT DRIVE ENGAGED - 1700 ENGINE RPM MAXIMUM POWER AT SELECTED TRAVEL SPEEDS

Power Hp (kW)	Drawbar pull lbs (kN)	Speed mph (km/h)	Crank- shaft speed rpm	Slip %	Fuel Consumption lb/hp.hr (kg/kW.h)	Hp.hr/gal (kW.h/l)	D.E.F. Consumption lb/hp.hr (kg/kW.h)	Temp. °F(°C) cool- ing med	Air dry bulb	Barom. inch Hg (kPa)
Speed setting 5										
85.0 (63.4)	13895 (61.82)	2.29 (3.69)	1756	12.8	0.554 (0.337)	12.31 (2.42)	0.046 (0.028)	181 (83)	77 (25)	29.5 (99.9)
Speed setting 6										
97.1 (72.4)	12800 (56.94)	2.84 (4.58)	1699	5.2	0.482 (0.293)	14.14 (2.78)	0.044 (0.027)	189 (87)	75 (24)	29.5 (99.9)
Speed setting 7.5										
99.4 (74.1)	10205 (45.39)	3.65 (5.87)	1699	2.9	0.455 (0.277)	14.97 (2.95)	0.041 (0.025)	187 (86)	79 (26)	29.5 (99.9)
Speed setting 9										
102.3 (76.3)	8570 (38.12)	4.48 (7.21)	1700	2.1	0.446 (0.271)	15.25 (3.00)	0.041 (0.025)	187 (86)	79 (26)	29.5 (99.9)
Speed setting 11										
105.7 (78.8)	7235 (32.19)	5.48 (8.81)	1704	1.6	0.444 (0.270)	15.38 (3.03)	0.031 (0.019)	189 (87)	73 (23)	29.5 (99.9)
Speed setting 13										
105.0 (78.3)	6160 (27.41)	6.39 (10.28)	1698	1.4	0.446 (0.271)	15.33 (3.02)	0.043 (0.026)	189 (87)	73 (23)	29.5 (99.9)
Speed setting 15										
107.4 (80.1)	5585 (24.85)	7.21 (11.60)	1704	1.1	0.446 (0.271)	15.33 (3.02)	0.038 (0.023)	187 (86)	72 (22)	29.5 (99.9)
Speed setting 17										
109.6 (81.7)	5005 (22.27)	8.21 (13.21)	1705	1.0	0.450 (0.274)	15.18 (2.99)	0.043 (0.026)	187 (86)	70 (21)	29.5 (99.9)
Speed setting 19										
111.7 (83.3)	4590 (20.41)	9.13 (14.68)	1705	0.9	0.457 (0.278)	14.95 (2.95)	0.041 (0.025)	187 (86)	70 (21)	29.5 (99.9)

REPAIRS AND ADJUSTMENTS: No repairs or adjustments.

REMARKS: All test results were determined from observed data obtained in accordance with official OECD test procedures. This tractor fell 1.3% short meeting the manufacturer's remote hydraulic flow claim of 29.1 GPM (110 l/min). This tractor fell 40.9% short meeting the manufacturer's 3 point lift claim at ball ends of 13140 lbs (5960 kg). The performance figures on this summary were taken from a test conducted under the OECD Code 2 test procedure.

We, the undersigned, certify that this is a true summary of data from OECD Report No. **3298**, Nebraska Summary 1215, December 20, 2022.

Roger M. Hoy
Director

P.J. Jasa
J.D. Luck
S. Pitla
Board of Tractor Test Engineers

TRACTOR SOUND LEVEL WITH CAB	Front Wheel Drive	
	Engaged dB(A)	Disengaged dB(A)
At no load at speed setting 4.7 mph (7.5 km/h)	72.5	72.0
Transport speed - at speed setting 24 mph (40 km/h)	70.5	70.5
Bystander	--	--

Horizontal distances of drawbar hitch point behind rear wheel axis - 32.1 in (815 mm), 36.0 in (915 mm)
38.0 in (965 mm)

TIRES AND WEIGHT

Rear Tires - No., size, ply & psi(kPa)
Front Tires - No., size, ply & psi(kPa)
Height of Drawbar
Static Weight with operator - Rear
- Front
- Total

Tested Without Ballast

Two 600/65R38;***;12(80)
Two 540/65R24;***;12(80)
17.9 in (455 mm)
7605 lb (3450 kg)
5370 lb (2435 kg)
12975 lb (5885 kg)

HYDRAULIC PERFORMANCE

CATEGORY: 3

Quick Attach: No

Lift cylinders:

Maximum force exerted through whole range:

on the frame: 8005 lbs (35.6 kN)

at hitch points: 9510 lbs (42.3 kN)

i) Sustained pressure at compensator cutoff: 2800 psi (193 bar)

two outlet sets combined

ii) Pump delivery rate at minimum pressure: 28.7 GPM (108.6 l/min)

iii) Pump delivery rate at maximum

hydraulic power: 26.3 GPM (99.6 l/min)

Delivery pressure: 2640 psi (182 bar)

Power: 40.5 HP (30.2 kW)

single outlet set

ii) Pump delivery rate at minimum pressure: 25.9 GPM (98.0 l/min)

iii) Pump delivery rate at maximum

hydraulic power: 25.3 GPM (95.6 l/min)

Delivery pressure: 2410 psi (166 bar)

Power: 35.5 HP (26.5 kW)

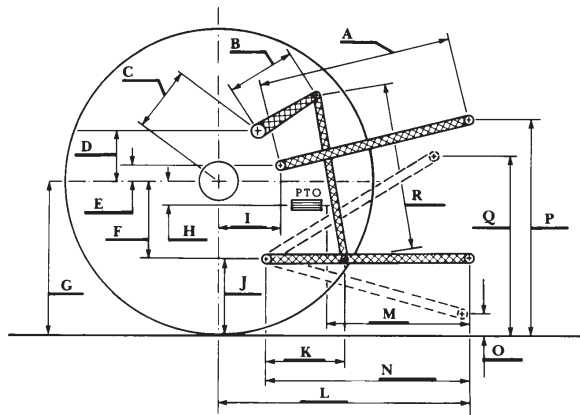

HITCH DIMENSIONS AS TESTED—NO LOAD

	inch	mm
A	31.9	810
B	11.8	300
C	15.9	404
D	15.3	388
E	10.4	264
F	8.1	205
G	32.5	825
H	1.0	25
I	11.3	287
J	24.4	620
K	20.8	529
L	39.8	1010
M	23.4	595
N	33.5	850
O	9.1	230
P	51.4	1305
Q	38.4	975
R	26.8	680

RECOMMENDED CITATION FORMAT:

NTTL.(2022). OECD tractor test 3298 for Fendt 314 Vario Gen4 Diesel.

Lincoln, NE:Nebraska Tractor Test Laboratory. Retrieved from <http://tractortestlab.unl.edu>