

University of Nebraska - Lincoln

DigitalCommons@University of Nebraska - Lincoln

Nebraska Tractor Tests

Tractor Test and Power Museum, The Lester F.
Larsen

2023

Nebraska Tractor Summary: S1259 Fendt 728 Vario Gen7

Nebraska Tractor Test Lab

Follow this and additional works at: <https://digitalcommons.unl.edu/tractormuseumlit>



Part of the [Energy Systems Commons](#), [History of Science, Technology, and Medicine Commons](#), [Other Mechanical Engineering Commons](#), [Physical Sciences and Mathematics Commons](#), [Science and Mathematics Education Commons](#), and the [United States History Commons](#)

This Article is brought to you for free and open access by the Tractor Test and Power Museum, The Lester F. Larsen at DigitalCommons@University of Nebraska - Lincoln. It has been accepted for inclusion in Nebraska Tractor Tests by an authorized administrator of DigitalCommons@University of Nebraska - Lincoln.

SUMMARY OF OECD TEST 3378 - NEBRASKA SUMMARY 1259 FENDT 728 VARIO GEN 7 DIESEL

POWER TAKE-OFF PERFORMANCE

Power HP (kW)	Crank shaft speed rpm	Diesel Consumption		D.E.F. Consumption		Mean Atmospheric Conditions
		Gal/hr (l/h)	lb/hp.hr (kg/kW.h)	Hp.hr/gal (kW.h/l)	Gal/hr (l/h)	
MAXIMUM POWER AND FUEL CONSUMPTION						
Rated Engine Speed—(PTO speed—1031 rpm)						
272.4 (203.1)	1700	14.16 (53.59)	0.362 (0.220)	19.24 (3.79)	1.06 (4.02)	
Standard Power Take-off Speed (1000 rpm)						
269.7 (201.1)	1649	13.95 (52.79)	0.360 (0.219)	19.34 (3.81)	1.06 (4.02)	
Maximum Power (1 hour)						
276.1 (205.9)	1500	14.13 (53.48)	0.357 (0.217)	19.54 (3.85)	1.04 (3.95)	

VARYING POWER AND FUEL CONSUMPTION

272.4 (203.1)	1700	14.16 (53.59)	0.362 (0.220)	19.24 (3.79)	1.06 (4.02)	Air temperature
235.5 (175.6)	1729	12.43 (47.05)	0.367 (0.223)	18.96 (3.73)	0.92 (3.48)	68°F (20°C)
178.6 (133.2)	1749	9.67 (36.58)	0.376 (0.229)	18.48 (3.64)	0.70 (2.65)	Relative humidity
120.4 (89.8)	1769	6.96 (26.33)	0.403 (0.245)	17.31 (3.41)	0.50 (1.90)	62%
60.9 (45.4)	1788	4.41 (16.70)	0.505 (0.307)	13.81 (2.72)	0.31 (1.16)	Barometer
--	1807	1.92 (7.25)	--	--	0.08 (0.29)	29.2" Hg (99.0 kPa)

Maximum torque - 1006 lb.-ft. (1364 Nm) at 1300 rpm

Maximum torque rise - 19.5%

Torque rise at 1400 engine rpm - 17%

Power increase at 1500 engine rpm - 1.4%

DRAWBAR PERFORMANCE UNBALLASTED - FRONT DRIVE ENGAGED FUEL CONSUMPTION CHARACTERISTICS

Power Hp (kW)	Drawbar pull lbs (kN)	Speed mph (km/h)	Crank- shaft speed rpm	Slip %	Fuel Consumption lb/hp.hr (kg/kW.h)	D.E.F. Consumption lb/hp.hr (kg/kW.h)	Temp. °F(°C)	Barom. inch Hg (kPa)
Power at Rated Engine Speed—Speed setting 9								
224.0 (167.0)	15000 (66.73)	5.60 (9.01)	1701	2.2	0.419 (0.255)	16.40 (3.23)	0.044 (0.027)	207 (97)
75% of Pull at Rated Engine Speed—Speed setting 9								
174.5 (130.1)	11280 (50.18)	5.80 (9.33)	1738	1.5	0.427 (0.260)	16.09 (3.17)	0.035 (0.035)	208 (98)
50% of Pull at Rated Engine Speed—Speed setting 9								
119.4 (89.0)	7490 (33.31)	5.98 (9.62)	1760	0.8	0.462 (0.281)	14.87 (2.93)	0.047 (0.029)	208 (98)
75% of Pull at Reduced Engine Speed—Speed setting 11								
174.5 (130.1)	11285 (50.20)	5.80 (9.33)	1429	1.5	0.403 (0.245)	17.06 (3.36)	0.035 (0.021)	208 (98)
50% of Pull at Reduced Engine Speed—Speed setting 11								
119.6 (89.2)	7520 (33.44)	5.97 (9.60)	1446	0.9	0.418 (0.254)	16.46 (3.24)	0.043 (0.026)	207 (97)

Location of tests: DLG TestService, GmbH, Max-Eyth-Weg 1, D-64823 Gross-Umstadt, Germany

Dates of tests: August to September, 2023

Manufacturer: AGCO GmbH Johann Georg Fendt Str 4 D-87616 Marktobendorf, Germany

CONSUMABLE Fluids: Fuel No. 2 Diesel Specific gravity converted to 60°/60°F (15°/15°C) 0.8355 Fuel weight 6.97 lbs/gal (0.834 kg/l) Diesel Exhaust Fluid (DEF) 32% aqueous urea solution DEF weight 9.071 lbs/gal (1.087 kg/l) Oil SAE 5W-30 API service classification CK-4 Transmission and hydraulic lubricant Extra Trans/STOU fluid Front axle lubricant Extra Trans/STOU fluid

ENGINE: Make AGCO Power Diesel Type six cylinder vertical with turbocharger, air to air intercooler and D.E.F. (diesel exhaust fluid) exhaust treatment Serial No. PLD 062040 Crankshaft lengthwise Rated engine speed 1700 Bore and stroke 4.331" x 5.197" (110.0 mm x 132.0 mm) Compression ratio 17.0 to 1 Displacement 459 cu in (7527 ml) Starting system 12 volt Lubrication pressure Air cleaner two paper elements and aspirator Oil filter one full flow cartridge Oil cooler engine coolant heat exchanger for crankcase oil, radiator for hydraulic and transmission oil Fuel filter one paper element and prestrainer Fuel cooler radiator for pump return fuel Exhaust DOC (diesel oxidation catalyst)/DPF (diesel particulate filter) System and SCR (selective catalyst reduction) with a vertical muffler Cooling medium temperature control thermostat and variable speed fan

CHASSIS: Type front wheel assist Serial No. WAM71023H00F01012 Tread width rear 74.7" (1897 mm) to 81.5" (2070 mm) front 78.6" (1997 mm) to 83.1" (2110 mm) Wheelbase 114.2" (2900 mm) Hydraulic control system direct engine drive Transmission Fendt Vario. A combination of mechanical and hydrostatic sections allow an infinite speed adjustment within the ranges noted. Nominal travel speeds mph (km/h) forward: 0 - 31 (0-50) reverse: 0-20 (0-33) Clutch a foot pedal controls the hydrostatic oil flow Brakes wet multiple disc hydraulically operated by two foot pedals that can be locked together Steering hydrostatic Power take-off 1000 rpm at 1649 engine rpm, economy PTO - 1000 rpm at 1432 engine rpm Unladen tractor mass 20525 lb (9310 kg)

DRAWBAR PERFORMANCE

UNBALLASTED - FRONT DRIVE ENGAGED - 1500 ENGINE RPM MAXIMUM POWER AT SELECTED TRAVEL SPEEDS

Power Hp (kW)	Drawbar pull lbs (kN)	Speed mph (km/h)	Crank- shaft speed rpm	Slip %	Fuel Consumption lb/hp.hr (kg/kW.h)	D.E.F. Consumption Hp.hr/gal (kg/kW.h)	Temp. °F(°C) cool- ing med	Air dry bulb	Barom. inch Hg (kPa)	
Speed setting 5.9										
183.7 (137.0)	22050 (98.08)	3.12 (5.03)	1617	15.0	0.500 (0.304)	13.86 (2.73)	0.049 (0.030)	208 (98)	66 (19)	29.5 (100.0)
Speed setting 6.9										
212.1 (158.2)	21200 (94.31)	3.75 (6.04)	1550	5.4	0.432 (0.262)	16.01 (3.15)	0.053 (0.032)	208 (98)	68 (20)	29.5 (100.0)
Speed setting 7.5										
219.1 (163.4)	20565 (91.48)	4.00 (6.43)	1498	4.2	0.422 (0.257)	16.42 (3.24)	0.038 (0.023)	217 (103)	64 (18)	29.5 (100.0)
Speed setting 9										
224.0 (167.0)	17140 (76.25)	4.90 (7.88)	1500	2.5	0.413 (0.251)	16.78 (3.31)	0.040 (0.024)	216 (102)	66 (19)	29.5 (100.0)
Speed setting 11										
224.1 (167.1)	13915 (61.89)	6.04 (9.72)	1499	1.6	0.408 (0.248)	16.95 (3.34)	0.052 (0.032)	214 (101)	66 (19)	29.5 (100.0)
Speed setting 13										
229.6 (171.2)	12165 (54.11)	7.08 (11.39)	1505	1.3	0.406 (0.247)	17.06 (3.36)	0.048 (0.029)	214 (101)	68 (20)	29.5 (100.0)
Speed setting 15										
231.3 (172.5)	10615 (47.23)	8.17 (13.15)	1499	1.2	0.408 (0.248)	16.95 (3.34)	0.049 (0.030)	210 (99)	68 (20)	29.5 (100.0)
Speed setting 17										
233.1 (173.8)	9480 (42.18)	9.22 (14.83)	1506	1.1	0.411 (0.250)	16.80 (3.31)	0.045 (0.028)	210 (99)	68 (20)	29.5 (100.0)
Speed setting 19										
234.0 (174.5)	8485 (37.75)	10.34 (16.64)	1506	1.0	0.414 (0.251)	16.73 (3.29)	0.036 (0.022)	208 (98)	68 (20)	29.5 (100.0)

REPAIRS AND ADJUSTMENTS: No repairs or adjustments.

REMARKS: All test results were determined from observed data obtained in accordance with official OECD test procedures. This tractor fell 29.3% short meeting the manufacturer's 3 point lift claim at ball ends of 24729 lbs (11216 kg). The manufacturer's remote hydraulic flow claim of 58.1 GPM (220 l/h) was not verified. The performance figures on this summary were taken from a test conducted under the OECD Code 2 test procedure.

We, the undersigned, certify that this is a true summary of data from OECD Report No. **3378**, Nebraska Summary 1259, May 22, 2024.

Roger M. Hoy
Director

P.J. Jasa
J.D. Luck
S.K. Pitla
Board of Tractor Test Engineers

TRACTOR SOUND LEVEL WITH CAB	Front Wheel Drive	
	Engaged dB(A)	Disengaged dB(A)
At no load at speed setting 4.7 mph (7.5 km/h)	64.4	64.4
Transport speed - at speed setting 31 mph (50 km/h)		67.4
Bystander		--

Horizontal distances of drawbar hitch point behind rear wheel axis - 38.2 in (970 mm), 40.2 in (1020 mm)
44.1 in (1120 mm), 46.1 in (1170 mm), 50.0 in (1270 mm)

TIRES AND WEIGHT

Rear Tires - No., size, ply & psi (kPa)

Front Tires - No., size, ply & psi (kPa)

Height of Drawbar

Static Weight with operator - Rear

- Front

- Total

Tested Without Ballast

Two 710/70R42;***;12(80)

Two 600/70R30;***;12(80)

18.0 in (455 mm)

12720 lb (5770 kg)

7970 lb (3615 kg)

20690 lb (9385 kg)

HYDRAULIC PERFORMANCE

CATEGORY: 3

Quick Attach: No

Lift cylinders:

Maximum force exerted through whole range:

on the frame: 15825 lbs (70.4 kN)

at hitch points: 19130 lbs (85.1 kN)

i) Sustained pressure at compensator cutoff: 2890 psi (199 bar)

two outlet sets combined

ii) Pump delivery rate at minimum pressure: 45.8 GPM (173.3 l/min)

iii) Pump delivery rate at maximum

hydraulic power: 43.7 GPM (165.4 l/min)

Delivery pressure: 2700 psi (186 bar)

Power: 68.9 HP (51.4 kW)

single outlet set

ii) Pump delivery rate at minimum pressure: 45.6 GPM (172.7 l/min)

iii) Pump delivery rate at maximum

hydraulic power: 43.6 GPM (165.1 l/min)

Delivery pressure: 2510 psi (173 bar)

Power: 64.0 HP (47.7 kW)

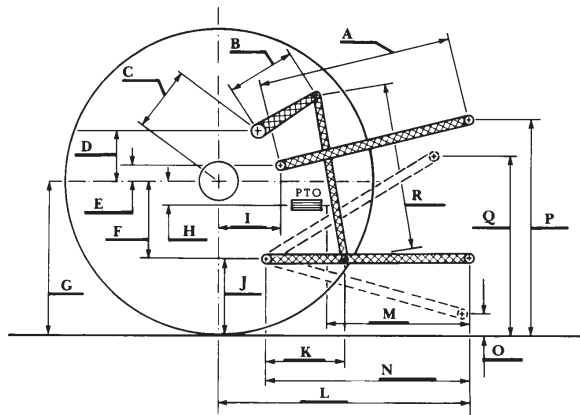

HITCH DIMENSIONS AS TESTED—NO LOAD

	inch	mm
A	31.9	810
B	15.0	380
C	16.8	427
D	14.0	355
E	8.5	215
F	12.4	315
G	38.4	975
H	2.4	60
I	11.8	300
J	26.0	660
K	22.8	580
L	51.4	1306
M	27.6	700
N	40.2	1020
O	9.1	230
P	52.9	1345
Q	42.0	1067
R	36.8	935

RECOMMENDED CITATION FORMAT:

NTTL.(2024). OECD tractor test 3378 for Fendt 728 Vario Gen 7 Diesel.

Lincoln, NE:Nebraska Tractor Test Laboratory. Retrieved from <http://tractortestlab.unl.edu>