

2015

MSYM 109: Physical Principles in Agriculture and Life Sciences—A Peer Review of Teaching Project Benchmark Portfolio

David Mabie

University of Nebraska-Lincoln, david.mabie@unl.edu

Follow this and additional works at: <http://digitalcommons.unl.edu/prtunl>

 Part of the [Agriculture Commons](#), [Higher Education Commons](#), and the [Higher Education and Teaching Commons](#)

Mabie, David, "MSYM 109: Physical Principles in Agriculture and Life Sciences—A Peer Review of Teaching Project Benchmark Portfolio" (2015). *UNL Faculty Course Portfolios*. 77.
<http://digitalcommons.unl.edu/prtunl/77>

This Portfolio is brought to you for free and open access by the Peer Review of Teaching Project at DigitalCommons@University of Nebraska - Lincoln. It has been accepted for inclusion in UNL Faculty Course Portfolios by an authorized administrator of DigitalCommons@University of Nebraska - Lincoln.

Benchmark Course Portfolio

MSYM 109: Physical Principles in Agriculture and Life Sciences

Spring 2015

David M. Mabie
Assistant Professor of Practice
Biological Systems Engineering
University of Nebraska-Lincoln
201 L.W. Chase Hall, Lincoln, NE 68583-0726
Phone: (402) 472-3066
Email: david.mabie@unl.edu Web: <http://bse.unl.edu/mabie>

Table of Contents

I. Abstract.....	3
II. Course Description and Objectives	3
A. Course Content.....	3
B. Course Objectives	3
C. Course Demographics.....	3
D. Portfolio Objectives	4
III. Course Components and Assessments.....	4
A. Lecture Component.....	4
1. Lecture Presentation.....	4
2. Example Problems	4
3. Clicker Questions.....	4
4. Exams.....	4
B. Recitation Component.....	5
C. Course Assessments.....	5
D. Course Materials	5
E. Assessment Rationale	5
IV. Analysis of Student Learning	6
A. Homework and Exam Case Study	6
B. Overview of Student Grades.....	9
V. Course and Portfolio Reflection.....	10
A. Reflection.....	10
B. Planned Changes	11
VI. Appendix A: Course Syllabus.....	12
VII. Appendix B: Exams.....	20

I. Abstract

This benchmark course portfolio was developed for MSYM 109 – Physical Principles in Agriculture and Life Sciences. The class is a general service course taken by majors as a prerequisite for future coursework along with several other CASNR majors to fulfill their physics course requirement. MSYM 109 is a high enrollment course, with 115 students in lecture, along with four separate 30 person recitation sections. This portfolio was developed to assess the following objectives:

1. Identify, evaluate, and justify the course objectives
2. Assess and evaluate the course pedagogy and assessment methodology
3. Analyze the historical students assessment results against the revised methods

II. Course Description and Objectives

A. Course Content

MSYM 109 is a technical and conceptual introduction to physics focusing on applications in agriculture and life sciences. It is a four credit hour course with three credits of lecture and one credit of recitation. There is also a one credit hour laboratory which is only required by about fifteen percent of the students who take the class. MSYM 109 is an introductory perspective of the following topics: mechanics, thermal physics, electricity and magnetism.

B. Course Objectives

Primary Objectives:

Meet ACE 4 purpose: Use scientific methods and knowledge of the natural and physical world to address problems through inquiry, interpretation, analysis, and the making of inferences from data, to determine whether conclusions or solutions are reasonable

Sufficiently prepare students (Mechanized Systems Management and Food Science and Technology majors) taking MSYM 109 as a prerequisite for future coursework

Secondary Objectives:

Improve science literacy as it applies to understanding the role physics plays in agriculture and life science

Demonstrate quantitative problem solving skills to apply physics in a variety of different circumstances

Encourage and promote an interest in the wide applicability of general physics

C. Course Demographics

There is a wide variety of students in the course ranging from first year to senior, non-major to major. The students typically have a varied background - some have taken physics in high school while others have not, some have completed math through calculus while others are taking trigonometry concurrently. Algebra and trigonometry are prerequisites for the course.

MSYM (major) students make up about ten percent of the overall lecture population and most of the laboratory. Typically the remaining class population is made up of the College of Agricultural Sciences and Natural Resources (CASNR) majors who are required to complete a physics course for their respective degree program(s). The students have a few other options offered by the physics department;

however most take MSYM 109 because of the agricultural and life sciences emphasis and to avoid traveling from east to city campus.

D. Portfolio Objectives

I chose this particular course because of the challenges the course presents. MSYM 109 is a broad, multi-disciplinary service course. The technical material of the course is not the difficult part to teach; most of the students would prefer to not take any physics course and attempting to change and challenge that mindset is the primary challenge the course presents. The main aspects I wish to address with this course portfolio are to re-evaluate the ACE and course objectives to determine the proper aspects of the course to emphasize, to refine my teaching methodology and pedagogy to improve the course, to more effectively engage students throughout the course to improve student attitudes, predispositions, and opinions of the topics. This benchmark portfolio will present a broad overview of the entire course.

III. Course Components and Assessments

A. Lecture Component

The lecture portion of the course consists of presentations of new concepts, working through example problems, conducting in-class clicker quizzes, and administering unit exams. Each portion of the lecture will be discussed below:

1. Lecture Presentation

The new material covered each day follows the style of a traditional lecture. PowerPoint slides are used to communicate new concepts and equations, example problems, and clicker questions. The students are provided with the slides online through blackboard as pdf's excluding the clicker questions and some of the example problems. There are also video recordings of the lectures online to allow students to re-listen to lecture or to catch up from absences. Scheduled guest lectures present during the semester on more specific applications of selected topics in real world settings.

2. Example Problems

A selection of practice problems are inserted into the lecture when appropriate to demonstrate the proper methods for solving each type of problem. The students are encouraged to work through these problems with peer discussion before the solution is presented. I typically solve the problems with the students on the white board in the front of the room. The students are constantly encouraged to think through the problem solving process as they are working on the solutions (i.e. - What concept is this question asking about? What equations could be appropriate? What do you know? What do you want to find out?).

3. Clicker Questions

Multiple choice clicker questions are used frequently during the course for three different purposes: to assess the student's conceptual understanding of the material, to provide opportunities for the student to practice applying their quantitative understanding of the material on multiple choice questions similar to the exams, and to survey the students or to take attendance.

4. Exams

Exams are scheduled every fourth week of the semester. The exams are proctored by the instructor and teaching assistants (TA's) during regularly scheduled class time. There are four semester exams, with the final simply being the fourth exam instead of a cumulative final exam. The exams have a conceptual section with ten short true/false, fill in the blank type questions, four to six short multiple choice quantitative questions, and one or two free response quantitative questions.

B. Recitation Component

The one credit hour for recitation is used as a question and answer time with students and to primarily focus on problem solving strategies for the previous weeks' worth of material. The students are encouraged to bring questions on topics that require more clarification or homework problems on which they need TA directed guidance. The students receive full credit for recitation through attendance and participation solving examples on the whiteboard. Since the recitation credit is not separate from the lecture credit hours, recitation grade is included as a portion of the lecture grade.

C. Course Assessments

Student learning is measured through grades on clicker questions (15%), homework assignments (20%), exams (55%) and recitation attendance (10%). Learning is also qualitatively measured through interaction in recitation sections and office hours where it is easier to determine what topics the students are struggling to understand. Student satisfaction and interest is more difficult to assess but is accomplished through clicker questions and an anonymous survey administered to the students at the midpoint and end of the semester.

The only activity outside of class the students are required to complete is the homework assignments. Each lecture topic has a small quantitative homework assignment and most lecture topics have a small conceptual assignment as well. The assignments are online, allowing the students unlimited access during the available time period to complete them. The homework assignments are structured to allow unlimited attempts so the students can achieve their desired level of understanding. Since this is an introductory course, the students' lack of experience applying the topics to quantitative solutions is something that requires extensive practice. An additional benefit of online homework is that it provides the student with instant feedback.

From these activities, I expect the students to be able to understand common units and terminology used in physics and to be able to improve in applying technical data and critically thinking about the material. The students are provided with office hours, recitation, and message boards among other methods to clarify answers they were not able to comprehend.

D. Course Materials

The materials used for the course include an introductory physics textbook, a student clicker, and blackboard via the internet. The textbook is necessary because it contains additional information on each topic that can't be completely taught during lecture as well as additional example problems and practice problems for the students. The clicker allows the instructor to take attendance during lecture and to readily assess the student's abilities to complete typical multiple choice questions. Blackboard is the method used to present the student's homework assignments, lecture materials, and grades. The students should use blackboard and the textbook often to prepare for lecture, exams and homework. Students are required to bring their clicker with them to each lecture to ensure they receive credit for the day's questions.

E. Assessment Rationale

The assessment methods used assist students to meet the goals of the course because they strive to meet the objectives and are an effective way to reach each student in the course. The methods for the course are centered on improving the student's problem solving abilities and thinking critically about physics topics. This is done through presenting the new ideas in the class while solving example problems, allowing the students to demonstrate their understanding of the material through clicker questions and homework assignments. These assessments are set up to allow the students the ability to correct mistakes through either automated feedback online or in class and recitation. This problem solving process is supported

through increased student engagement and interest by incorporating more discussion centric clicker questions into every lecture and by gearing the examples and homework assignments around topics in agriculture and life sciences.

Since this is an introductory course the students typically do not have much experience with physics. The course does build upon previous math skills such as trigonometry and algebra but still starts with a review of these math topics while slowly integrating them into beginning physics topics of unit conversions and vectors. The methods help to prepare students for the broader university curriculum by presenting to them how physics topics are interconnected to agriculture and life sciences and real world situations. Since most of the students in the class are in an agricultural or natural resources major, an appreciation for the application of math to the real world will aide them in their future careers. A general understanding of the problem solving process and analysis of technical data will also benefit any student regardless of discipline. It is these two skills that each student should improve on throughout this course that will benefit them beyond graduation.

IV. Analysis of Student Learning

A. Homework and Exam Case Study

Two significant changes have been made to the course in the last couple of years. These include converting from a weekly quiz structure to four exams spread out over the semester and converting from a weekly paper homework submission to an online homework system. These changes resulted in significant improvements in student evaluation responses but have not been investigated to determine if student grades and learning have improved. Old homework, quiz, and exam grades were separated to correspond to each current unit exam.

Homework grades were analyzed in Table 1 looking at the overall class average during each of the last six semesters. Between the spring 2014 and fall 2014 semesters the homework system was changed from a weekly paper submission to several small online assignments, as stated earlier. The major findings through this analysis show that average student homework grades have improved under the new homework system during every unit and students are completing homework for the fourth unit exam significantly more often. From the fall 2012 through spring 2014 semesters, students were allowed to drop their two lowest homework assignment grades. After the third exam, most students would choose to not complete the final two homework assignments, choosing to use those as their two dropped grades which can explain the large discrepancy between the spring and fall exam 4 grades.

A similar analysis comparing student exam grades is shown below in Table 2. Between the spring 2013 and fall 2013 semesters the course converted from a weekly quiz system to four quarterly exams. This change also replaced the final cumulative exam with the fourth quarterly exam. This analysis shows that the students have performed significantly better over the second unit under the exam system and slightly better during the third unit. The students are allowed to drop their lowest exam score which explains the low attempt rate on exam four during the last four semesters. Typically most students are satisfied with their grades at the end of the semester and choose to not take the fourth exam.

Another possible explanation for the improved exam scores is the increased amount of instruction time the students are receiving. In the previous quiz system, the recitation credit hour would consist of 20 minutes of student questions and answers regarding homework and preparation for the upcoming quiz. The final 30 minutes of recitation was reserved for students to take the weekly exam. This format also created an unfair system for students because each recitation section attempted the same quiz. The recitation sections were spread out at four different times between Wednesday and Thursday. In the exam format all of the students attempt the exam every fourth week during the lecture. This change has removed three hours of lecture during the semester but increased six hours of recitation time for the students.

Table 1 Student Homework Grades

Homework Stats for Exam 1	Fall 12	Spring 13	Fall 13	Spring 14	Fall 14	Spring 15
Average	87.56	86.46	83.91	86.03	91.27	91.78
Completion %	97.20%	96.03%	94.42%	93.64%	92.74%	92.84%
Standard Deviation	8.37	10.50	10.56	8.75	8.41	8.05
Median	88.75	88.75	85.00	90.63	91.21	93.50
Mean - Median	-1.19	-2.29	-1.09	-4.59	0.06	-1.72

Homework Stats for Exam 2	Fall 12	Spring 13	Fall 13	Spring 14	Fall 14	Spring 15
Average	89.36	82.59	89.12	89.17	94.77	94.16
Completion %	96.26%	93.22%	95.39%	92.95%	91.36%	93.56%
Standard Deviation	9.45	7.77	9.29	9.55	6.42	7.53
Median	90.00	83.75	91.67	90.63	96.67	96.35
Mean - Median	-0.64	-1.16	-2.54	-1.46	-1.89	-2.19

Homework Stats for Exam 3	Fall 12	Spring 13	Fall 13	Spring 14	Fall 14	Spring 15
Average	85.15	85.25	84.13	84.89	88.71	90.39
Completion %	96.50%	92.99%	89.08%	87.27%	93.62%	91.20%
Standard Deviation	11.40	8.71	9.33	13.11	10.61	8.54
Median	86.25	87.50	85.00	86.46	89.72	91.32
Mean - Median	-1.10	-2.25	-0.87	-1.57	-1.02	-0.94

Homework Stats for Exam 4	Fall 12	Spring 13	Fall 13	Spring 14	Fall 14	Spring 15
Average	86.89	92.51	79.34	92.06	93.78	91.80
Completion %	40.19%	81.78%	44.17%	22.05%	86.36%	83.67%
Standard Deviation	15.09	9.26	17.69	12.73	8.66	8.71
Median	90.00	97.50	80.00	97.50	95.76	93.48
Mean - Median	-3.11	-4.99	-0.66	-5.44	-1.97	-1.68

Table 2 Student Exam/Quiz Grades

Exam Stats	Fall 12 Quiz 1-4	Spring 13 Quiz 1-4	Fall 13 Exam 1	Spring 14 Exam 1	Fall 14 Exam 1	Spring 15 Exam 1
Average	71.44	77.52	64.37	75.12	74.24	72.71
Completion %	98.36%	97.43%	100%	98%	100%	100%
Standard Deviation	11.62	11.13	16.01	16.97	12.61	15.45
Median	71.67	78.13	65.50	76.50	72.50	75.00
Mean - Median	-0.22	-0.60	-1.13	-1.38	1.74	-2.29

Exam Stats	Fall 12 Quiz 5-8	Spring 13 Quiz 5-8	Fall 13 Exam 2	Spring 14 Exam 2	Fall 14 Exam 2	Spring 15 Exam 2
Average	62.57	72.42	82.75	83.14	80.55	76.06
Completion %	97.66%	96.96%	100%	100%	100%	100%
Standard Deviation	14.14	10.81	16.01	16.97	17.34	17.88
Median	60.00	73.75	86.50	89.00	81.00	79.00
Mean - Median	2.57	-1.33	-3.75	-5.86	-0.45	-2.94

Exam Stats	Fall 12 Quiz 9-12	Spring 13 Quiz 9-12	Fall 13 Exam 3	Spring 14 Exam 3	Fall 14 Exam 3	Spring 15 Exam 3
Average	79.22	79.34	86.77	81.20	74.13	80.53
Completion %	97.90%	95.79%	96%	98%	100%	100%
Standard Deviation	11.62	9.72	11.75	13.00	16.00	17.56
Median	80.63	80.00	90.00	82.50	77.00	83.00
Mean - Median	-1.41	-0.66	-3.23	-1.30	-2.87	-2.47

Exam Stats	Fall 12 Quiz 13-14	Spring 13 Quiz 13-14	Fall 13 Exam 4	Spring 14 Exam 4	Fall 14 Exam 4	Spring 15 Exam 4
Average	68.42	71.40	65.05	69.34	61.10	62.16
Completion %	89.72%	87.85%	18%	37%	44%	34%
Standard Deviation	17.01	18.51	18.57	18.57	16.06	20.05
Median	70.00	72.50	66.00	70.00	62.50	62.00
Mean - Median	-1.58	-1.10	-0.95	-0.66	-1.40	0.16

B. Overview of Student Grades

The spring 2015 course officially had 112 students enrolled. Three students withdrew resulting in a 97% retention rate. The course has an official capacity limit of 114. The spring semesters generally see a slight increase in retention due to the greater number of students graduating who cannot retake the course in a later semester but a 97% retention rate is similar to most semesters. At the end of the semester I submitted 109 course grades which can be seen in Figure 1. The grades are presented below grouping by letter for a clearer presentation of grades. There were four pass/no pass student grades which were converted to letter grades for this presentation; all four students passed the course. The overall course average for the spring semester was an 83.00%. This corresponds to a B- to B final letter grade. The last six semesters all had similar final average grades, typically somewhere between a C+ and B.

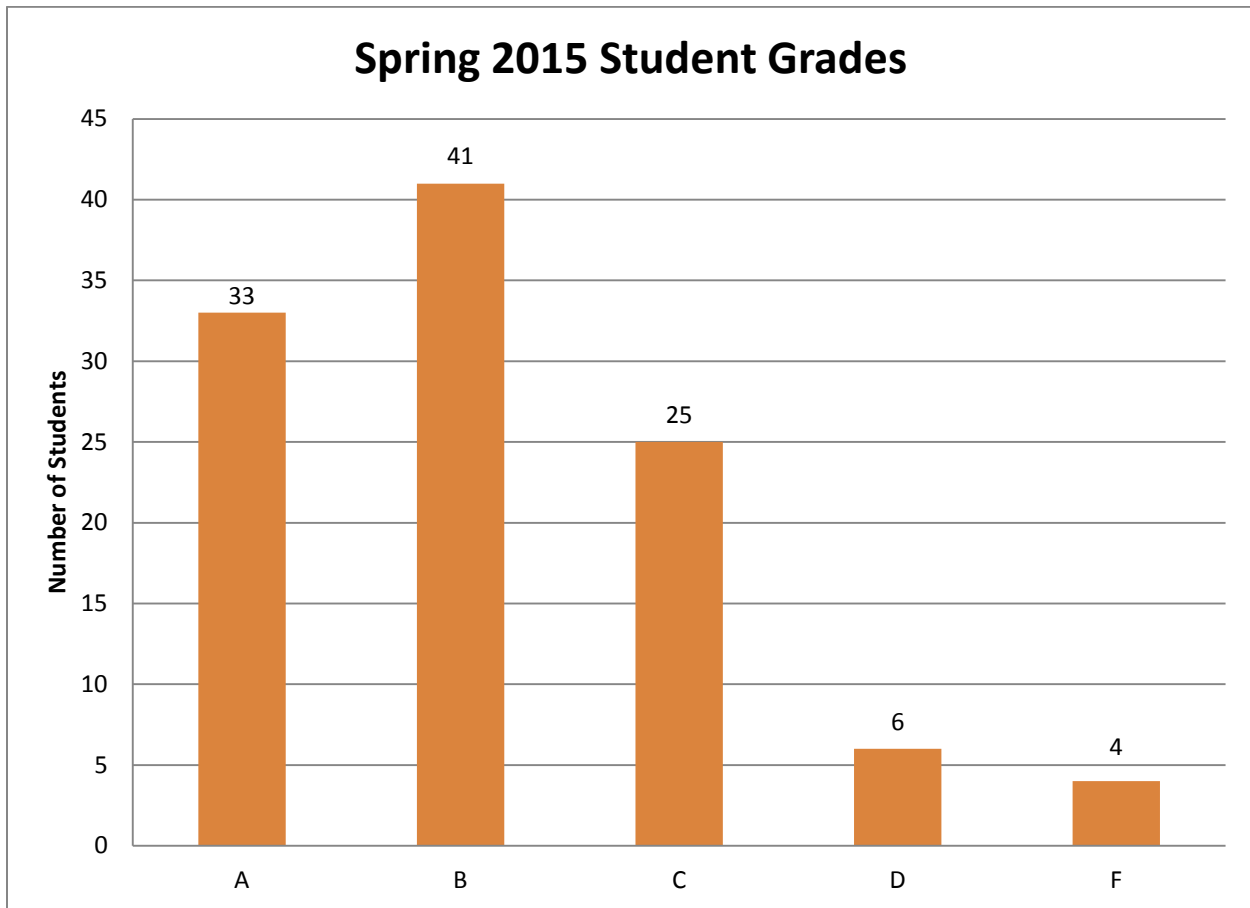

Figure 1 Spring 2015 Student Grades

Student grades were then compared grouping the entire academic year together. Since significant changes were made at the start of each of the previous two fall terms, this grouping can provide a better view of trends and is presented in Figure 2. One noticeable trend is the large improved grade shift seen from 2012-2013 (quiz format) to both 2013-2014 and 2014-2015 academic years (exam formats). This shift would imply the subtle improvements seen in student exam and homework scores had larger impacts on the final student grades. Another uninvestigated change is the replacement of a cumulative final with the fourth semester exam. Students rarely improved their grade with the cumulative final and on average experienced a drop of at least 3% on their overall grade after the final. This change could also explain some of the improvement in student final course grades.

Another small trend between the 2013-2014 and 2014-2015 academic years is the small distribution of the B range grades to more A's and C's. This could simply be noise in the data and would require more information to validate; however this could also be an effect of homework system changes. The new homework system allows proactive students the ability to receive instant feedback and repeat the

assignments, so students can ensure they receive full credit on their homework. The online homework system does generally require more effort on the part of the students, which can explain some of the trends in the data. The proactive students can ensure they achieve full credit on homework and therefore a higher overall grade while the students who procrastinate are unlikely to achieve full points on the homework thereby receiving a lower final grade.

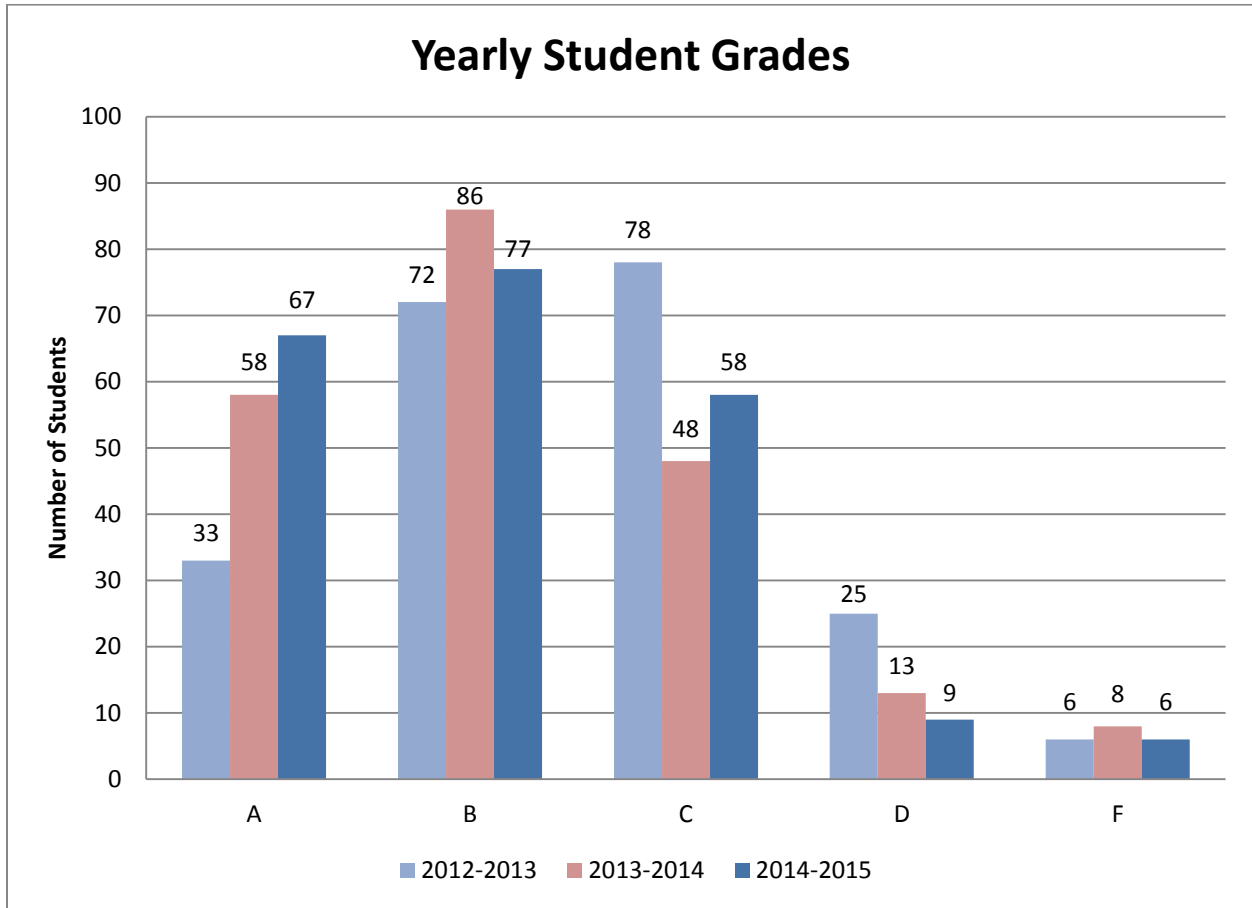

Figure 2 Student Grades from 2012 to 2015

V. Course and Portfolio Reflection

A. Reflection

Overall, participation in the peer review process provided beneficial insight into improving MSYM 109 through the concept of backwards design and has allowed for continuous improvement by encouraging the implementation of more intentional changes into the course. Since I began teaching MSYM 109 in the spring of 2012, I have made several changes to the methodology of course materials and pedagogy of the course that have benefitted the class. Being able to reflect on those changes in such an investigative and intentional manner and re-evaluating my course objectives and assessment strategies has been a helpful experience.

The exam and homework structural changes are just two parts of what has been modified in the course over the last two years. However these were the two major changes. The change of shifting from quizzes to exams was received very positively by the students as the student evaluation scores jumped from a 20th percentile ranking up to a 43rd percentile ranking. There is sufficient evidence to keep the same exam

structure in the course since not only did it show clear improvement in student satisfaction but it also indicates improved student learning.

It is not apparent yet whether the students have taken to the homework system with the same level of satisfaction; however it was again indicative that students have learned more under this new system. Changes may need to be made to the delivery and structure of the online homework problems but for now it is a useful system that should remain as a part of the course.

B. Planned Changes

In the near future I intend to investigate three possible changes to the course. The first is to renovate the recitation sections. While the current system has been received well by the students as a useful time to practice applying the concepts, more should be done to ensure that the students are being actively engaged during recitation. The average student attends their recitation section and pays little attention while receiving full credit for simply being physically present. The recitation section would be a great opportunity to introduce more intentional activities to have the student engage in active team based learning applying the concepts to simplistic versions of real world problems. These activities could then be graded and returned to the student, therefore requiring more active participation. This change could also help standardize the recitation sections between different TA's.

Another necessary change is to renovate the lab section. Since the lab section is a separate credit hour from the course, not every major is required to take the lab. Therefore the lab could cover more specific applied content to the majors requiring the lab section. Along with this change I would like to include more hands-on, real world projects and to include some competition aspects.

The third intended future change is to re-evaluate the content of the course. While the class has seen plenty of renovations directed at changing the methodology of the course delivery, less has been done focusing on the course content. To address this concern I would like to survey most of the respective majors for which the course serves and determine what faculty from other departments would like to see their students achieve through taking this course. After understanding what the needs of the stakeholders are the content of the course can be re-evaluated.

VI. Appendix A: Course Syllabus

MSYM 109 – Physical Principles in Agriculture and Life Sciences

Course Syllabus – Spring 2015

Instructor:

Mr. David Mabie

201 L.W. Chase Hall

Office Phone: (402) 472-3066 Email: david.mabie@unl.edu

Office Hours: By Appointment

Support Staff:

Natalie Howery - Recitation Assistant

Office Hours: 3 – 4 W, LWC 149

Email: [REDACTED]

Bethany Brittenham - Recitation TA

Office Hours: 6 – 7 W, LWC 116

Email: [REDACTED]

Collin Erickson - Recitation TA

Office Hours: 3 – 4 R, LWC 113

Email: [REDACTED]

Christian Schwenka – Recitation TA

Office Hours: 6 – 7 R, LWC 116

Email: [REDACTED]

Course Info:

(ACE 4) [ES] 109. **Physical Principles in Agriculture and Life Sciences** (4 cr I, II) Lec 3, Rec 1.

Prerequisites: MATH 101 or 103 with a grade of C or better completed within the last 11 months; or placement in MATH 102 or 104 (or higher) within the last 11 months. *Students cannot receive credit for both MSYM 109 and another first course in physics.*

	<u>Section</u>	<u>Day</u>	<u>Time</u>	<u>Room</u>
Lecture:	150	Mo We Fr	11:00-11:50	LWC 116
Recitations:	151	We	7:00-7:50	LWC 112
	152	We	4:00-4:50	LWC 112
	153	Th	4:00-4:50	LWC 112
	154	Th	7:00-7:50	LWC 112

Objectives:

Fundamental principles of mechanics, heat, electricity, magnetism and their relationships to energy utilization and conservation will be applied to agricultural and life sciences situations.

Upon completion of this course a student should be able to:

- Define common terminology used in physics.
- Interpret technical data and apply it to practical problems.
- Explain and demonstrate principles of mechanics, heat, and electricity applied to agriculture and life sciences.
- Demonstrate quantitative problem-solving skills by setting up and solving problems related to agricultural and life sciences situations in a logical and systematic manner.

Ace Learning Outcome:

(see ACE Governing Document #4, Section VII, A.)

Student Learning Outcome 4: Use scientific methods and knowledge of the natural and physical world to address problems through inquiry, interpretation, analysis, and the making of inferences from data, to determine whether conclusions or solutions are reasonable.

Ace Learning Opportunities:

Opportunities to achieve the learning objective are embedded in the course through lectures, assigned readings, problem sets, and class demonstrations. A comprehensive process of

repetitive problem solving, designed to manifest a thorough understanding of relationships between physical systems and their behavior, and to hone use of scientific methods, will provide the framework for the course. This process will be comprised of four distinct phases. The first phase will consist of discerning what is the system and its components, what data are available (which are obtained from the problem statement, a diagram, a graph, a reference table, or some combination of all), and what key physical principles and laws apply to the system. The second phase will hypothesize which physical principles and laws, and data are applicable in order to develop a plan (i.e., what is the best way to approach the problem, what mathematical relations and methods are required, what can be inferred from existing data, what intermediate information must be obtained, what defines a solution?). The plan will be implemented in the third phase through detailed analysis including accurate execution of the mathematical relations relevant to the underlying physical principles. Critical evaluation of how realistic the solution is will constitute the fourth and final phase of problem solving. Within the evaluation will be checking of units, reconfirmation of quantities via back calculations, and judgment on whether the magnitude of quantities of the solution are within reasonable physical limits. Students will have the opportunity to learn the principles and process of science through the considered use of number of engagement pedagogies. Lectures and assigned readings will be integrated to convey content knowledge that is essential for students to apply basic physics and engineering concepts to solve agriculture and life science-based problems. Furthermore, problem sets and lecture demonstrations will provide opportunities for the application of various aspects of the scientific method and problem solving. The weekly problem sets will require students to employ formulas and physical principles (interpretation) to generate solutions (analysis) to the problem sets. Weekly recitation sessions will reinforce lecture and reading materials, and promote interactive learning in an environment conducive to small-group discussion. Exams and problems sets will also require students to make inferences and determine if solutions are reasonable.

Ace Learning Assessment:

In order to assess student achievement, random problem sets, exams and clicker quizzes will be collected. Each week, homework that requires the application of the previous week's principles but also requires the retention of earlier ideas will be administered. Exams will cover basic ideas but also will incorporate critical-thinking problems in which students must apply principles to an agriculture and life science-based situation that they may experience in an on-farm or industrial setting. The students will be expected to use the problem-solving process and its traits of inquiry, interpretation, and analysis to organize the information given, correctly convert units, recognize concept equations and then prepare a solution. Following the solution, students will make deductions from the data and determine if their answer is in fact reasonable for the given situation.

Methods:

- Three 1-hour lectures per week, including visual aids, models, and illustrations of physical concepts and their applications in agriculture and life sciences. Lecture topics shown in course schedule and exams.
- One 1-hour recitation per week. Assigned homework or similar problems will be discussed, graded work will be returned and exam reviews will occur as needed. Students are encouraged to bring questions to recitation.

Materials:

- Customized Applied Physics, 2007, Paul E. Tippens. McGraw – Hill , Inc., New York, 7th edition (required).
- Homework Problems Booklet, Updated 2008, Kocher (optional)

- IClicker2 from the university (required)

Required Supplies:

- 8 ½”x11” paper
- No. 2 pencil and eraser
- Calculator with trigonometric functions

Course Website:

Blackboard will be used to post lecture materials, homework assignments, and scores for graded work throughout the semester. Access blackboard via <http://my.unl.edu>

Scoring:

Grades will be determined by points earned on weekly homework assignments, exams, recitation and in-class clicker quizzes.

• Homework	20 %
• Recitation Attendance	10 %
• Lecture Clicker Quizzes	15 %
• Exams ('top' 3)	<u>55 %</u>
Total:	100 %

Final grades:

Final grades will be based upon accumulated points as a percentage of the total points available. Blackboard will show raw scores and provide totals from which students can track their progress throughout the semester. Final grades will be based upon adjusted point totals using 'top' scores - lowest exam score will be dropped. Letter grades and percentages required for respective grades are:

<u>Average</u>	<u>Grade</u>	<u>Average</u>	<u>Grade</u>	<u>Average</u>	<u>Grade</u>
96.7 – 100%	A+	83.3 – 86.7%	B	70.0 – 73.3%	C-
93.3 – 96.7%	A	80.0 – 83.3%	B-	66.7 – 70.0%	D+
90.0 – 93.3%	A-	76.7 – 80.0%	C+	63.3 – 66.7%	D
86.7 – 90.0%	B+	73.3 – 76.7%	C	60.0 – 63.3%	D-
				0 – 60.0%	F

Pass/no pass option:

Students choosing this grading option must achieve at least 70% of the total points to receive a passing grade. Students have the responsibility to determine if this grading option is acceptable for their respective majors/academic programs.

Course Policies:

Attendance) Each student is responsible for all material covered in class lectures and recitations. Attendance at lecture and recitations is essentially required. Note that a portion of the points comes from lecture and recitation attendance and participation. If a student cannot attend his/her regular recitation during a given week, he/she should attend another recitation. Notify the teacher of the recitation in advance of your intent to attend his or her section.

Academic Dishonesty) “Students are expected to adhere to guidelines concerning academic dishonesty outlined in Section 4.2 of the University’s Student Code of Conduct (<http://stuafs.unl.edu/ja/code/>). The BSE Department process for grade and academic dishonesty appeals can be found at <http://bse.unl.edu/academicadvising-index>. Students are encouraged to contact the instructor for clarification of these guidelines if they have questions or concerns.”

Homework Problems) Homework will be assigned for each lecture. Homework will be due by 8:00 AM on Fridays the week after the homework is assigned. **Late homework is not accepted.** Pay attention to due dates posted on blackboard. The assignments are on blackboard using Maple T.A. software. Each student will have unlimited attempts to achieve the desired

grade while the homework sets are available.

Weekly Recitation) The weekly recitation will primarily focus on practice problems. The student will also earn attendance and participation points in recitation as well as an occasional pop quiz. If for some reason a student cannot attend their regularly scheduled session, notify the instructor in advance and attendance of another recitation will be allowed at the instructor's discretion.

Lecture Clicker Quizzes) Lecture clicker quizzes will be given during lecture periods daily throughout the semester. Questions will include quantitative and conceptual multiple choice questions focusing on the current or preceding lecture.

Exams) Four exams will be conducted during the semester. A student's 'top' 3 exams will be counted towards the final grade. Note that the final exam is not comprehensive and is not required if you are satisfied with your grade after the first 3 exams. Exams will be closed book and closed notes. Students will be provided with an equation sheet and necessary tables/constants for each exam. If for some reason a student cannot attend the regularly scheduled exam, notify the instructor in advance and the student will be allowed at the instructor's discretion to take the exam. Exam must be completed before planned absence. Make-up exams will only be allowed for medical reasons with a doctor's note. Students must put their full name and student ID number on the exam.

Discussion Board) All students are encouraged to post in the discussion board any questions during the course, especially when seeking homework help outside of office hours or recitation. This is also a helpful resource if you are stuck on a problem as another student may have already posted on the board regarding your specific question earlier. If you are uncomfortable using your name please use the anonymous option to post questions. If you require more one on one help with solving problems then the office hours would be a better option.

Recommendations for success in this course

This course involves a lot of **quantitative** problem solving. Algebra is an extremely important tool for this work (which explains why algebra is a prerequisite for this course). Following the list of suggestions below should improve your learning (and grade).

1. Work on this class **regularly**. A lot of material is presented and constant reviewing helps keep it fresh in your mind. Taking it in small bites makes it much easier to digest!
2. **Work ahead!** Read the reading assignment before coming to the lecture. Take any notes that you think will help you remember important points. You might want to write all the concept equations and variable definitions on 3x5 cards as a handy reference when working problems. Read the example problems (in the chapter) and be sure you know the reasoning behind each step. Be sure to note any questions you have on the material. Pick a few of the problems at the end of the chapter and try to work them. Note any difficulties or questions you have doing this.
3. **You need to come to class!** Pay attention to the lecture. Take notes on the important points that you did not notice in your advance reading. **Don't be afraid to ask questions!**
4. Review your reading and lecture notes before working the homework problems, **concentrating on the ideas or concepts** involved. (It's very important to understand the concepts before applying them to solve problems! The concepts typically relate equations to physical situations.) Work all the assigned homework problems in a well organized format. Note any difficulties or questions that you have in working the problems. Working together on homework is allowed and I will also be available during office hours to answer questions.

Work extra problems. Work (or read) enough problems so you are confident you can read a problem and **immediately** know which concept to use to solve it.

5. Bring your completed homework problem solutions, calculator, paper, pencil and eraser to recitation. Ask any homework or lecture questions you may have. Learn from the questions asked by other students and the answers given. Work the exam problems in a well organized format. Attach the selected homework problem solutions.
6. Take note of the chapters from which problems will be selected for the exams. Review your notes, homework problem solutions, and quizzes for those chapters

In spite of the warnings, you should know that many students have told their instructor(s) that they unexpectedly enjoyed this class. Much of the course material is physical, tangible, and describes the behavior of physical elements and systems. There is much practical knowledge presented in the material. Best wishes for a great class, and a great semester!

Problem Solving Process

- 1) Discern what is the system and its components, what data are available (which are obtained from the problem statement, a diagram, a graph, a reference table, or some combination of all), and what key physical principles and laws apply to the system. *“What’s given?”*
- 2) Hypothesize which physical principles and laws, and data are applicable in order to develop a plan (i.e., what is the best way to approach the problem, what mathematical relations and methods are required, what can be inferred from existing data, what intermediate information must be obtained, what defines a solution?). *“Which concepts?”*
- 3) Implement the plan through detailed analysis including accurate execution of the mathematical relations germane to the underlying physical principles. *“Solve it!”*
- 4) Critical evaluation of how realistic the solution is will constitute the final phase of problem solving. *“Check it!”*

Emergency Response Information:

- **Fire Alarm (or other evacuation):** In the event of a fire alarm: Gather belongings (Purse, keys, cellphone, N-Card, etc.) and use the nearest exit to leave the building. Do not use the elevators. After exiting notify emergency personnel of the location of persons unable to exit the building. Do not return to building unless told to do so by emergency personnel.
- **Tornado Warning:** When sirens sound, move to the lowest interior area of building or designated shelter. Stay away from windows and stay near an inside wall when possible.
- **Active Shooter**
 - o **Evacuate:** if there is a safe escape path, leave belongings behind, keep hands visible and follow police officer instructions.
 - o **Hide out:** If evacuation is impossible secure yourself in your space by turning out lights, closing blinds and barricading doors if possible.
 - o **Take action:** As a last resort, and only when your life is in imminent danger, attempt to disrupt and/or incapacitate the active shooter.
- **UNL Alert:** Notifications about serious incidents on campus are sent via text message, email, unl.edu website, and social media. For more information go to: <http://unlalert.unl.edu>.

- Additional Emergency Procedures can be found here:
http://emergency.unl.edu/doc/Emergency_Procedures_Quicklist.pdf

Students with Special Needs:

Students with disabilities are encouraged to contact the instructor for a confidential discussion of their individual needs for academic accommodation. It is the policy of the University of Nebraska-Lincoln to provide flexible and individualized accommodation to students with documented disabilities that may affect their ability to fully participate in course activities or to meet course requirements. To receive accommodation services, students must be registered with the Services for Students with Disabilities (SSD) office, 132 Canfield Administration, 472-3787 voice or TTY.

TENTATIVE COURSE SCHEDULE:

1/12	Introduction, Technical Mathematics	Chap. 1; 2
1/14	Significant Digits and Dimensional Analysis, Vectors	Chap. 3.1-3.9
1/16	Vectors, Motion in a Straight Line	Chap. 3.9-3.14; 6.1-6.3
1/19	Martin Luther King Day – No Class	
1/21	Motion in a Straight Line, Acceleration	Chap. 6.4-6.6
1/23	Motion in a Vertical Plane Equilibrium (Gravitational acceleration, projectile motion)	Chap. 6.7-6.10
1/26	Motion in a Vertical Plane (cont.)	Chap. 6.7-6.10
1/28	Laws of Motion and Equilibrium	Chap. 4.1-4.6
1/30	Friction	Chap. 4.7
2/2	Torque and Center of Gravity	Chap. 5
2/4	Newton's Second Law (Relationship between force, mass, and acceleration)	Chap. 7.1-7.3
2/6	Newton's Second Law (cont.)	Chap. 7.3-7.4
2/9	Work and Energy	Chap. 8.1-8.5
2/11	Conservation of Energy	Chap. 8.6
2/13	Exam 1	
2/16	Conservation of Energy, and Power	Chap. 8.7-8.8
2/18	Momentum	Chap. 9.1-9.3
2/20	Simple Machines	Chap. 12.1-12.7
2/23	Elasticity (springs)	Chap. 10.1-10.4
2/25	Uniform Circular Motion	Chap. 13.1-13.4
2/27	Harmonic Motion	Chap. 14.1-14.5
3/2	Harmonic Motion (cont.)	Chap. 14.5-14.9
3/4	Waves – Sound	Sound PPT
3/6	Waves – Light	Light PPT
3/9	Fluids at Rest (Density, Specific Gravity and Pressure)	Chap. 15.1-15.4
3/11	Fluids at Rest (Archimedes' Principle, Hydraulic Press)	Chap. 15.1-15.4
3/13	Exam 2	
3/16	Fluids in Motion (Fluid Flow)	Chap. 15.5-15.6
3/18	Fluids in Motion (Bernoulli's Equation)	Chap. 15.7-15.10
3/20	Temperature and Expansion	Chap. 16.1-16.8
3/21 – 3/29	Spring Break No Class	
3/30	Heat and Internal Energy	Chap. 17.1-17.6
4/1	Transfer of Heat	Chap. 18.1-18.5
4/3	Thermal Properties of Matter (Gas laws)	Chap. 19.1-19.5
4/6	Thermal Properties of Matter (Liquefaction, vaporization, humidity)	Chap. 19.6-19.10
4/8	Thermodynamics (First and Second Laws)	Chap. 20.1-20.9
4/10	Thermodynamics (cont.), Air Properties	Chap. 20.10-20.13
4/13	Psychrometric Chart	Psychrometrics PPT
4/15	Psychrometric Processes	Psychrometrics PPT
4/17	Exam 3	
4/20	Electric Current and Resistance Continued	Chap. 27.1-27.7
4/22	Direct Current Circuits	Chap. 28.1-28.4
4/24	Direct Current Circuits (cont.)	Chap. 28.4-28.6
4/27	Capacitance	Chap. 26.1-26.6
4/29	Circuit Problems	
5/1	Final Exam Review	
5/6	Exam 4, 10:00-12:00 in Chase Hall 116	

Tentative Recitation Schedule:

Week 1	Chapters 1, 2, 3
Week 2	Chapter 6
Week 3	Chapters 4, 6
Week 4	Chapters 4, 5, 7
Week 5	Exam 1 Review (Covers Chapters 1 – 7)
Week 6	Chapters 8, 9
Week 7	Chapters 10, 12, 13
Week 8	Chapter 14 and Waves
Week 9	Exam 2 Review (Covers Chapters 8 – 14 and Waves)
Week 10	Chapter 15
Week 11	Chapters 16, 17, 18
Week 12	Chapters 19, 20
Week 13	Exam 3 Review (Covers Chapters 15 – 20)
Week 14	Chapters 27, 28 and Psychrometrics
Week 15	Exam 4 Review (Covers Chapters 26 – 28, and Psychrometrics)

VII. Appendix B: Exams

MSYM 109
Exam 1A Spring 2015

Name: _____
NU ID#: _____

Instructions:

Do Not open until instructed to do so.

You must show work to receive any partial credit for problems.

Do not use your book. Any tables or constants you may need are provided at the **back**.

If you need more space to work a problem, I have additional paper.

If you have a question, please raise your hand and I will answer as soon as possible.

You have one hour to work the exam. I will post time updates on the front board.

Good Luck!

True / False or Fill in the Blank Section (20 pts)

1. (2 pts) Newton's _____ Law states: The acceleration (a) of an object in the direction of the resultant force (F) is directly proportional to the magnitude of the force and inversely proportional to the mass (m).
2. (2 pts) (True/False) Velocity is equal to the rate of change in time.
3. (2 pts) The unit for force in SI units is _____.
4. (2 pts) If a force creates a _____ rotation about the axis, the torque will be considered positive.
5. (2 pts) The number 3.0628×10^3 has _____ significant figures.
6. (2 pts) A force has both _____ and _____.
7. (2 pts) The weight of an object due to gravity is equal to _____ multiplied by _____.
8. (2 pts) A displacement of 13 miles to the southwest is considered a (scalar/vector) quantity.
9. (2 pts) Acceleration is the rate of change in _____.
10. (2 pts) (True/False) An astronaut's mass on earth is equal to their mass on the moon.

Extra Credit

1. (2 pts) If you complete all 4 exams, how many are you allowed to drop?
2. (2 pts) What is the name of your recitation TA?

Short Answer or Multiple Choice Section (60 pts)

1. (10 pts) Make the following unit conversions:

a) $230 \frac{\text{miles}}{\text{hour}} = \frac{\text{km}}{\text{second}}$

b) $765 \frac{\text{lbs}}{\text{in}^2} = \frac{\text{N}}{\text{m}^2}$

c) $983.3 \frac{\text{kg}}{\text{m}^3} = \frac{\text{mg}}{\text{cm}^3}$

2. (10 pts) Find the resultant of the two forces $\mathbf{F}_1 = 300 \text{ N @ } 200.0^\circ$ and $\mathbf{F}_2 = 250 \text{ N @ } 15.0^\circ$.

A) 55.4 N @ 43°

B) 275 N @ 223°

C) 55.4 N @ 223°

D) 275 N @ 43°

3. (10 pts) Captain Jack Sparrow and Will Turner are sword fighting on a 6 m long, weightless plank that is supported by a fulcrum over shark infested waters. If Captain Jack and Will have body masses of 77.1 kg and 68.5 kg, respectively, where must the fulcrum be placed so that the plank is maintained in equilibrium? Assume they are standing on the edges of the platform.

- A) 1.9 meters from Captain Jack
- B) 2.8 meters from Captain Jack
- C) 3.2 meters from Captain Jack
- D) The center (3 meters from either edge)

4. (10 pts) French basketball player Kadour Ziani is the current world record holder for having the highest standing vertical of 60 inches. What minimum velocity did he have to jump with to set this world record?

- A) 9.9 ft/s
- B) 18 ft/s
- C) 62 ft/s
- D) 320 ft/s

5. (10 pts) A Deere 7200R Tractor weighs 23,000 pounds and has a drawbar capacity (how large of a load it can pull) of 10,000 pounds. If the coefficient of friction between the tractor and ground is 0.6 on a flat surface, how much force must the engine produce to accelerate the tractor at 1 ft/s^2 ?

- A) 10,730 lbs
- B) 12,350 lbs
- C) 24,500 lbs
- D) 33,000 lbs

6. (10 pts) The world record of pumpkin chucking is 4694.68 feet from the launch point. If I make my own pumpkin launcher and release a pumpkin with an initial velocity of 300 ft/s at an angle of 45 degrees, will I beat the record?

A) Yes

B) No

C) It will tie the record

D) None of the Above

Analytical Section (20 pts)

1. (20 pts) Santa Claus is on a snowy roof when he suddenly slips and falls. The top of the roof, where he's standing, is 5 feet above the edge and makes an angle of 28 degrees with the horizontal (see the picture below). If Santa weighs 300 lbs and the coefficient of friction between him and the roof is 0.32, (A) what is his acceleration as he slides down the roof?, (B) what is his velocity right before he falls off the roof?

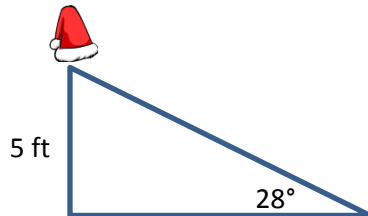

Useful Equations:

SOHCAHTOA: $\sin \theta = \frac{opp}{hyp}$; $\cos \theta = \frac{adj}{hyp}$; $\tan \theta = \frac{opp}{adj}$

Pythagorean Theorem: $a^2 + b^2 = c^2$

Quadratic Equation: $x = \frac{-B \pm \sqrt{B^2 - 4AC}}{2A}$ from: $Ax^2 + Bx + C = 0$

Resultant Vectors: $R = \sqrt{R_x^2 + R_y^2}$

Newton's 2nd Law: $F = ma$

Friction Force: $F_k = \mu_k N$; $F_s = \mu_s N$

Translational Equilibrium: $\sum F_x = 0$; $\sum F_y = 0$

Torque: $\tau = Fr$

Rotational Equilibrium: $\sum \tau = 0$

Weight: $W = mg$

Translational Forces: $\sum F_x = ma$; $\sum F_y = ma$

Kinematics Equations

Non Accelerated Motion: $d = vt$

Accelerated Motion Eq 1: $V_f = V_i + at$

Accelerated Motion Eq 2: $d = \frac{1}{2}at^2 + V_i t$

Accelerated Motion Eq 3: $d = \frac{1}{2}at^2 - V_f t$

Accelerated Motion Eq 4: $d = \frac{V_f + V_i}{2} t$

Accelerated Motion Eq 5: $V_f^2 - V_i^2 = 2ad$

Useful Constants:

Gravitational acceleration: $g = 9.8 \text{ m/s}^2 = 32 \text{ ft/s}^2$

Useful Conversions:

1 N = 0.225 lb

1 m = 100 cm

1 m = 39.37 in

1 m = 3.281 ft

1 km = 1000 m

1 ft = 12 in

1 hr = 60 min = 3600 sec

1 mile = 5280 ft

1 kg = 1000 g

1 g = 1000 mg

1 km = 0.62 mi

MSYM 109

Exam 2A Spring 2015

<p>Name: _____</p> <p>NU ID#: _____</p>

Instructions:

Do Not open until instructed to do so.

You must show work to receive any partial credit for problems.

Do not use your book. Any tables or constants you may need are provided at the **back**.

If you need more space to work a problem, I have additional paper.

If you have a question, please raise your hand and I will answer as soon as possible.

You have one hour to work the exam. I will post time updates on the front board.

Good Luck!

True/False or Fill in the Blank Section (20 pts)

1. (2 pts) A watt is equivalent to a _____ per second.
2. (2 pts) Young's Modulus is equivalent to _____ divided by _____.
3. (2pts) When an object is stretched and permanently deforms, it has exceeded its _____ limit.
4. (2 pts) (True/False) In simple harmonic motion, the acceleration is greatest when the oscillating body reaches its amplitude.
5. (2 pts) (True/False) The English unit for power is the Joule.
6. (2 pts) _____ is equivalent to mass multiplied by velocity.
7. (2 pts) (True/False) A period is the time required to complete one cycle of motion.
8. (2 pts) (True/False) Centripetal acceleration is always pointed toward the center of the circular motion.
9. (2 pts) _____ is equal to the change in an object's momentum.
10. (2 pts) The standard unit for frequency is the _____.

Bonus

1. (2 pts) Is a femur (thigh bone) more resistant to a compressional or tensional force?
2. (2 pts) What is today's date?

Short Answer or Multiple Choice Section (60 pts)

1. (10 pts) How much energy does an ultraviolet wave possess if it has a wavelength of 200 nanometers?

- (a) 9.95×10^{-19} J
- (b) 2.50×10^{-18} J
- (c) 6.45×10^{-17} J
- (d) 1.99×10^{-16} J

2. (10 pts) The Empire State Building is 1,454 feet tall. King Kong weighs 20 tons and he climbs to the very top. If he jumps off the top, what is his velocity when he reaches the base of the building?

- (a) 32.1 ft/s
- (b) 169 ft/s
- (c) 243 ft/s
- (d) 306 ft/s

3. (10 pts) A 80-g mass is attached to a spring ($k=10 \text{ N/m}$) and released with an amplitude of 20 cm. What is the velocity of the mass when it is halfway to the equilibrium position (10 cm)?

(a) 1.94 m/s

(b) 2.74 m/s

(c) 6.12 m/s

(d) 8.66 m/s

4. (10 pts) A 2013 Lamborghini engine has an average horsepower of 700 hp with a 6.5 liter engine. If it consumes an average of 125,000 ftlbs of energy every 2.9 seconds how efficient is the engine?

A) 893 %

B) 68 %

C) 32 %

D) 11 %

5. (10 pts) In an Olympic bobsled competition, a team takes a turn of radius 24 feet at a speed of 60 mph. How many g 's do passengers experience? ($1 g = 32 \text{ ft/s}^2$)

- (a) 3.9 g 's
- (b) 4.7 g 's
- (c) 8.4 g 's
- (d) 10 g 's

6. (10 pts) A car traveling at 8 m/s crashes into a car of identical mass stopped at a traffic light. What is the velocity of both of the cars after the collision, assuming this is a completely inelastic collision?

- (a) 2 m/s
- (b) 4 m/s
- (c) 8 m/s
- (d) 16 m/s

Analytical Section (20 pts)

A 9.52 gram bullet is fired into a 6 kilogram block of wood that is suspended from a cord. If the impact of the bullet causes the block to swing to a height 10 cm above its starting position, find the velocity of the bullet when it strikes the block.

Useful Equations:

Weight: $W = mg$

Work: $W = Fd$

Kinetic Energy: $K = \frac{1}{2}mv^2$

Potential Energy: $U = mgh$

Conservation of Energy: $U_i + K_i + W_{in} = U_f + K_f + W_{out}$

Power: $Power = \frac{work}{time}$

Momentum: $P = mv$

Conservation of Momentum: $m_1u_1 + m_2u_2 = m_1v_1 + m_2v_2$

Coefficient of Restitution: $e = \frac{v_2 - v_1}{u_1 - u_2}$

Period: $T = \frac{1}{f}$

Circular Velocity: $v = \frac{2\pi R}{T} = 2\pi Rf$

Centripetal Force: $F_c = ma_c$

Centripetal Acceleration: $a_c = \frac{v^2}{R}$

Efficiency: $\eta = \frac{Work_{out}}{Work_{in}} = \frac{Power_{out}}{Power_{in}} = \frac{M_A}{M_I}$

Stress: $Stress = \frac{F}{A}$

Strain: $Strain = \frac{\Delta l}{l}$

Young's Modulus: $Y = \frac{F/A}{\Delta l/l}$

Spring Conservation of Energy: $\frac{1}{2}kA^2 = \frac{1}{2}kx_i^2 + \frac{1}{2}mv_i^2 = \frac{1}{2}kx_f^2 + \frac{1}{2}mv_f^2$

SHM Displacement: $x = A\cos(2\pi ft)$

SHM Acceleration: $a = -4\pi^2 f^2 A\cos(2\pi ft)$

Period of Simple Pendulum: $T = 2\pi \sqrt{\frac{L}{g}}$

EM Wavelength:

$$c = \lambda f$$

EM Energy:

$$E = hf$$

Useful Constants:

Gravitational Acceleration: $g = 9.8 \frac{m}{s^2} = 32 \frac{ft}{s^2}$

Baseline Intensity: $I_o = 1 \times 10^{-12} \frac{W}{m^2}$

Speed of Light: $c = 3 \times 10^8 \frac{m}{s}$

Plank's Constant: $h = 6.63 \times 10^{-34} Js$

Unit Conversions:

1 MegaNewton = 1,000,000 Newtons

*1 Horsepower = 550 ft*lbs/s*

1 MegaPascal = 1,000,000 Pascals

1 mile = 5,280 ft

1 meter = 1,000,000,000 nanometers

1 ton = 2000 lbs

MSYM 109

Exam 3A Spring 2015

<p>Name: _____</p> <p>NU ID#: _____</p>

Instructions:

Do Not open until instructed to do so.

You must show work to receive any partial credit for problems.

Do not use your book. Any tables or constants you may need are provided at the **back**.

If you need more space to work a problem, I have additional paper.

If you have a question, please raise your hand and I will answer as soon as possible.

You have one hour to work the exam. I will post time updates on the front board.

Good Luck!

True / False or Fill in the Blank Section (20 pts)

1. (2 pts) The amount of heat needed to melt one kilogram of a substance is called the substance's _____?
2. (2 pts) (True / False) An increase in fluid velocity results in an increased pressure at the constriction in a venture meter.
3. (2 pts) (True / False) Bernoulli's equation is only valid if one assumes turbulent flow.
4. (2 pts) (True / False) All objects emit electromagnetic radiation, regardless of their temperature or the temperature of their surroundings.
5. (2 pts) A material with a lower thermal conductivity (corkboard) will transfer heat (better / worse) than one with a higher thermal conductivity (copper).
6. (2 pts) The buoyant force exerted on an object immersed in a fluid is equal to the _____?
7. (2 pts) What are the three modes of heat transfer?
8. (2 pts) (True / False) Condensation is the process of going from a gas to a liquid.
9. (2 pts) When applying the ideal gas law, one must use the (absolute (K, R) / relative (C, F)) temperature scales.
10. (2 pts) Two objects at thermal equilibrium will be at the same _____?

Bonus

1. (2 pts) From John Hay's guest lecture, why is a C-4 plant more efficient than a C-3 plant?
2. (2 pts) From Derek Heeren's guest lecture, what are two kinds of irrigation?

Short Answer or Multiple Choice Section (60 pts)

1. (10 pts) A diver jumps from a platform 20 feet above the water. If the person dives to a depth of 8 feet under the water, how much pressure (absolute) do they feel on their person?

- A) 3.5 psi
- B) 12.1 psi
- C) 18.2 psi
- D) 26.8 psi

2. (10 pts) The Nuclear Power Plant in Fort Calhoun, NE can output work at a rate of 502 mega Joules every second. If the plant is 60 % efficient, how much heat is lost to the water used to cool the nuclear reactor?

- A) 215 MJ
- B) 335 MJ
- C) 717 MJ
- D) 837 MJ

3. (10 pts) An average human person has a body temperature of $37\text{ }^{\circ}\text{C}$ and their emissivity can be approximated to be 0.5. How much power do they radiate if you assume the person is a cylinder with a surface area of 4.5 m^2 ?

A) 0.24 W

B) 524 W

C) 1,178 W

D) 2,356 W

4. (10 pts) A car tire has dropped in pressure to 18 psi (absolute) overnight because the outside temperature dropped to -10 degrees C . What mass of air needs to be added to the tire to return it to 34 psi (absolute) if there was originally 7 pounds of air in the tire? (assume no change in volume)

A) 3.4 lbs

B) 6.2 lbs

C) 10.7 lbs

D) 13.2 lbs

5. (10 pts) One of the ghosts of clicker past is floating next to you in the lecture room. If the ghost tries to poke you with an invisible oak stick, what is your heat transfer rate to the ghost? Assume the sticks dimensions are 0.5 m long and 1 cm in diameter and that you are a warm 37 °C and the ghost is a very cold 3 Kelvin.

- A) 0.85 mW
- B) 7.7 mW
- C) 56 mW
- D) 49 W

6. (10 pts) Oil is moving in a horizontal pipe at a flow rate of 60 m³/min. If the pipe diameter expands from 2 meters to 5 meters, how much will the pressure rise in the constriction?

- A) 2.6 Pa
- B) 42 Pa
- C) 84 Pa
- D) 151 kPa

Analytical Section (20 pts)

1. (20 pts) It is the middle of a bitter winter and overnight, a Starbucks coffee shop's HVAC system breaks down, letting all the liquid coffee (400 kg of it) inside freeze. The employees walk in to find the coffee frozen at a temperature of $-16\text{ }^{\circ}\text{C}$, but they can only serve hot coffee at $54.4\text{ }^{\circ}\text{C}$. Assuming that coffee has the same thermal properties as water,

(A) How much heat is needed to be applied to the coffee to ensure customer satisfaction?

(B) If the furnace can only output 10 kW of power, how long (in hours) will it take to melt the coffee?

Useful Equations:

Mass Density:

$$\rho = \frac{m}{V}$$

Power:

$$P = \frac{\text{energy}}{\text{time}} = \frac{Q}{t}$$

Pressure:

$$P = \frac{F}{A} = \rho gh = Dh$$

Absolute Pressure:

$$P_{abs} = P_{atm} + P_{gauge}$$

Hydraulic Press Mechanical Adv:

$$M_l = \frac{F_o}{F_i} = \frac{S_i}{S_o}$$

Archimedes' Principle:

$$F_B = mg = V\rho g$$

Continuity (Fluid Flow):

$$Q = v_1A_1 = v_2A_2$$

Bernoulli's Equation:

$$P_1 + \rho gh_1 + \frac{1}{2}\rho v_1^2 = P_2 + \rho gh_2 + \frac{1}{2}\rho v_2^2$$

Temperature Conversion (F to C):

$$^{\circ}\text{F} = 1.8^{\circ}\text{C} + 32$$

Temperature Conversion (F to R):

$$R = ^{\circ}\text{F} + 460$$

Temperature Conversion (C to K):

$$K = ^{\circ}\text{C} + 273$$

Specific Heat Capacity:

$$Q = mC_p\Delta T$$

Latent Heat of Fusion:

$$Q = mL_f$$

Latent Heat of Vaporization:

$$Q = mL_v$$

Conduction:

$$H = \frac{Q}{t} = \frac{kA\Delta T}{L}$$

Radiation:

$$R = \frac{P}{A} = e\sigma T^4$$

General Gas Law:

$$\frac{P_1V_1}{m_1T_1} = \frac{P_2V_2}{m_2T_2}$$

Ideal Gas Law:

$$\frac{P_1V_1}{n_1T_1} = \frac{P_2V_2}{n_2T_2} \quad ; \quad PV = nRT$$

Mole to Mass Conversion:

$$m = nM$$

Relative Humidity:

$$RH = \frac{\text{actual vapor pressure}}{\text{saturated vapor pressure}}$$

1st Law of Thermodynamics:

$$\Delta Q = \Delta W + \Delta U$$

Engine Efficiency:

$$e = \frac{(T_{in} - T_{out})}{T_{in}} = \frac{(Q_{in} - Q_{out})}{Q_{in}} = \frac{W_{out}}{Q_{in}}$$

Coefficient of Performance:

$$K = \frac{T_{cold}}{T_{hot} - T_{cold}} = \frac{Q_{cold}}{Q_{hot} - Q_{cold}} = \frac{Q_{cold}}{W_{in}}$$

Useful Constants:

Universal gas constant (R): $R = 0.0821 \frac{L \text{ atm}}{\text{mol K}} = 8.314 \frac{J}{\text{mol K}}$

Gravitational constant (g): $g = 9.8 \frac{m}{s^2} = 32 \frac{ft}{s^2}$

Atmospheric Pressure: $P_{atm} = 1 \text{ atm} = 14.7 \text{ psi} = 101.3 \text{ kPa}$

Water mass Density: $\rho = 1000 \frac{kg}{m^3}$

Water weight Density: $D = 62.4 \frac{lbs}{ft^3}$

Oil mass Density: $\rho = 850 \frac{kg}{m^3}$

Oil weight Density: $D = 53.4 \frac{lbs}{ft^3}$

Stephan-Boltzman Constant (σ): $\sigma = 5.67 \times 10^{-8} \frac{W}{m^2 K^4}$

Specific Heat Capacity of Water: $c_p = 4.187 \frac{kJ}{kg \text{ } ^\circ C}$

Specific Heat Capacity of Ice: $c_p = 2.09 \frac{kJ}{kg \text{ } ^\circ C}$

Latent Heat of Fusion of Water: $L_f = 334 \frac{kJ}{kg}$

Latent Heat of Vaporization of Water: $L_v = 2,257 \frac{kJ}{kg}$

Melting point of Water: $T (mp) = 0 \text{ } ^\circ C$

Boiling point of Water: $T (bp) = 100 \text{ } ^\circ C$

Thermal Conductivity of Oak: $k = 0.16 \frac{W}{m K}$

Unit Conversions:

1 atm = 14.7 psi = 101.3 kPa

1 cm³ = 1 mL

1 horsepower = 550 ft*lbs/s

1 BTU = 778 ft*lbs = 1,055 J

1 hour = 60 minutes = 3,600 seconds

1 kW = 1,000 W = 1,000,000 mW

1 kN = 1,000 N = 1,000,000 mN

1 kPa = 1,000 Pa = 1,000,000

MSYM 109

Exam 4 Spring 2015

<p>Name: _____</p> <p>NU ID#: _____</p>

Instructions:

Do Not open until instructed to do so.

You must show work to receive any partial credit for problems.

Do not use your book. Any tables or constants you may need are provided at the **back**.

If you need more space to work a problem, I have additional paper.

If you have a question, please raise your hand and I will answer as soon as possible.

You have one hour to work the exam. I will post time updates on the front board.

Good Luck!

True / False or Fill in the Blank Section (20 pts)

1. (2 pts) The psychrometric process of humidification requires a _____ shift on the psychrometric chart.
2. (2 pts) The psychrometric process of cooling requires a _____ shift on the psychrometric chart.
3. (2 pts) (True/False) At least two properties are necessary to determine the state point on a psychrometric chart.
4. (2 pts) (True / False) Kirchhoff's laws apply for circuits that contain at least 1 source of emf.
5. (2 pts) The unit of an electromotive force is the _____.
6. (2 pts) (True / False) 1 Volt is equal to 1 Joule divided by 1 Coulomb.
7. (2 pts) (True / False) The current is the same in all parts of a parallel circuit.
8. (2 pts) (True / False) The resistivity of a wire is independent of the length of the wire.
9. (2 pts) The unit of the resistor is the _____.
10. (2 pts) (True / False) Voltage increases across a resistor.

Bonus

1. (2 pts) The Benz limit is the maximum amount of energy that can be taken out of the wind, what percent is it?

2. (2 pts) What was your favorite unit of this class?

Short Answer or Multiple Choice Section (40 pts)

1. (10 pts) How much enthalpy is there when the dry bulb temperature is equal to $35\text{ }^{\circ}\text{C}$ and the wet bulb temperature is $27\text{ }^{\circ}\text{C}$?

- A) 0.9 kJ/kg
- B) 27 kJ/kg
- C) 70 kJ/kg
- D) 85 kJ/kg

2. (10 pts) What is the current through the $6\ \Omega$ resistor in the following circuit?

- A) 85 mA
- B) 266 mA
- C) 351 mA
- D) 543 mA

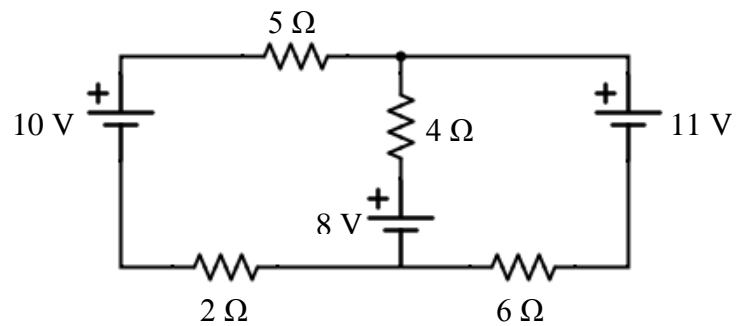

3. (10 pts) Find the equivalent resistance in the circuit below.

- A) 0.72Ω
- B) 1.1Ω
- C) 8.5Ω
- D) 24Ω

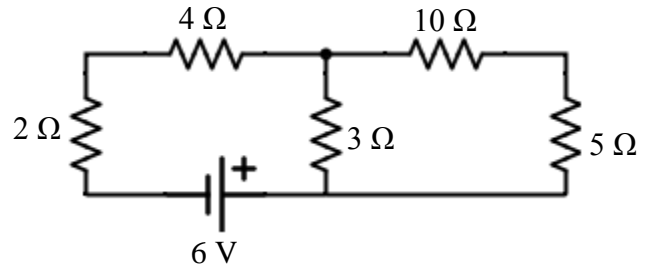

4. (10 pts) Find the resultant capacitance in the circuit below

- A) $0.72 \mu\text{F}$
- B) $1.1 \mu\text{F}$
- C) $8.5 \mu\text{F}$
- D) $24 \mu\text{F}$

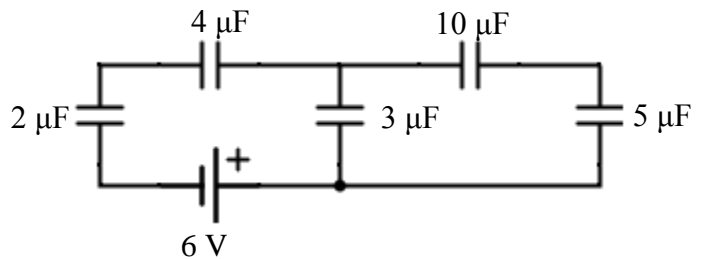

Free Response Section (40 pts)

1. (20 pts) How much energy is needed per hour to heat cold air at 25°C dry bulb and 20% RH to 40°C? Assume your fan blows the cold air at 10 m³/min. Also, how much power does your fan need?

2. (20 pts) I want to dry 450 bushels of corn initially at 17 % moisture content down to 13 % moisture content. Assume your fan can output 1000 ft^3 per minute of air initially at 90°F and 20% RH through the grain and the air exits the grain at 70% RH. If you need to remove 10,000 lbs of water from the grain, how long will this take to complete?