

1-1958

## *Physics*, Chapter 38: Mirrors and Lenses

Henry Semat  
*City College of New York*

Robert Katz  
*University of Nebraska-Lincoln, rkatz2@unl.edu*

Follow this and additional works at: <http://digitalcommons.unl.edu/physickatz>



Part of the [Physics Commons](#)

---

Semat, Henry and Katz, Robert, "Physics, Chapter 38: Mirrors and Lenses" (1958). *Robert Katz Publications*. 180.  
<http://digitalcommons.unl.edu/physickatz/180>

This Article is brought to you for free and open access by the Research Papers in Physics and Astronomy at DigitalCommons@University of Nebraska - Lincoln. It has been accepted for inclusion in Robert Katz Publications by an authorized administrator of DigitalCommons@University of Nebraska - Lincoln.

## Mirrors and Lenses

## 38-1 Spherical Mirrors

A spherical mirror consists of a small section of the surface of a sphere with one side of the surface covered with a polished reflecting material, usually silver or aluminum. If the outside, or convex surface, is silvered, we have a *convex* mirror; if the inside, or concave surface, is silvered, we have a

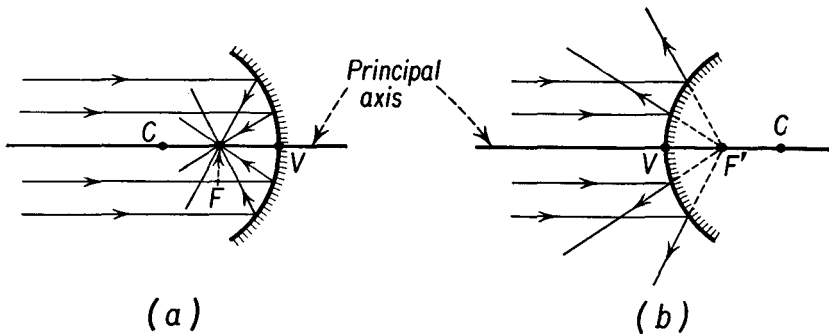

**Fig. 38-1** Light parallel to the principal axis (a) converges toward  $F$  after reflection from a concave mirror, and (b) diverges from  $F'$  after reflection from a convex mirror.

*concave* mirror, as shown in Figure 38-1. Most mirrors used commercially are made of glass, with the rear surface silvered and then coated with a layer of paint or lacquer for protection. Mirrors for astronomical telescopes or other accurate scientific work are provided with a reflective coating on the front surface, for back-silvered mirrors give rise to two images, one from the glass-air interface and one from the glass-silver interface. This results in a loss of light from the primary reflection from the silvered surface. In the following discussion only front-surface mirrors will be considered. As a convention we will draw our diagrams in such a way that light incident upon the optical system is traveling from left to right.

The paths of light rays incident upon the surface of a mirror may be determined by application of the laws of reflection. The *principal axis* of a mirror is a line through the *center of curvature*  $C$  of the mirror, and the vertex  $V$ , as shown in Figure 38-1. A bundle of rays parallel to the principal axis of a concave mirror will be reflected from the mirror to converge to a point on the principal axis, called the *principal focus*  $F$  of the mirror, provided that the diameter of the mirror is small compared to its radius of curvature  $R$ . The principal focus lies midway between the vertex  $V$  and the center of curvature  $C$  of the mirror. A beam of light parallel to the principal axis of a convex mirror appears to diverge from a virtual focus  $F'$  after reflection from the mirror. As in the case of the concave mirror, the point  $F'$  lies midway between the vertex of the mirror and its center of curvature.

### 38-2 Image Formation in Spherical Mirrors

Let us examine the path of a ray of light  $PA$  emitted by a source at  $P$  and reflected from a concave mirror at  $A$ , as shown in Figure 38-2. The vertex of the mirror is at  $V$ , and the line  $PV$  is the principal axis of the mirror.

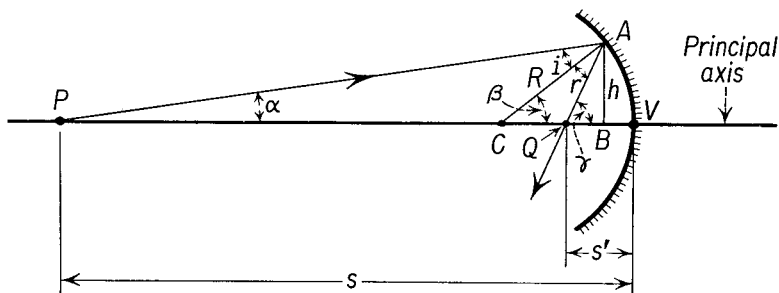

Fig. 38-2

The center of curvature of the mirror is at point  $C$ . To find the direction of the reflected ray at  $A$ , we draw the radius  $CA$ , of length  $R$  from the center of curvature  $C$  to the point  $A$ . The reflected ray  $AQ$  is drawn so that the angle of incidence  $PAC$  (or  $i$ ) is equal to the angle of reflection  $CAQ$  (or  $r$ ). The reflected ray intersects the principal axis of the mirror at point  $Q$ . Let us label the angle  $APC$  by  $\alpha$ , the angle  $ACQ$  by  $\beta$ , and the angle  $AQB$  by  $\gamma$ . Since the exterior angle of a triangle is equal to the sum of the interior angles, we find from triangle  $APC$  that

$$\beta = \alpha + i,$$

while from triangle  $ACQ$  we find that

$$\gamma = \beta + r.$$

Making use of the fact that  $i = r$ , we find that

$$\alpha + \gamma = 2\beta.$$

If the mirror represents a small section of a spherical surface, the angles  $\alpha$ ,  $\beta$ , and  $\gamma$  are small and may be taken as equal to their tangents. We designate the length  $AB$  of the perpendicular from  $A$  to the principal axis as  $h$ , the distance  $PV$  of the source to the vertex of the mirror as  $s$ , the distance  $QV$  as  $s'$ , and the distance  $CV$  as  $R$ . In addition we shall take the distance  $BV$  as negligibly small. We then have

$$\alpha = \tan \alpha = h/s,$$

$$\beta = \tan \beta = h/R,$$

and

$$\gamma = \tan \gamma = h/s'.$$

Substituting these results into the preceding equation, we find

$$\frac{1}{s} + \frac{1}{s'} = \frac{2}{R}. \quad (38-1)$$

The above equation was derived by examination of a single reflected ray, under the restriction that the ray made a small angle with the principal axis of the mirror. Such a ray is called a *paraxial ray*. Since the ray chosen was arbitrary, all paraxial rays emitted from  $P$ , at an object distance  $s$  from the vertex of a concave mirror of radius  $R$ , will intersect at the point  $Q$ , called the image point, located an image distance  $s'$  from the vertex of the mirror. Since angle  $i$  equals angle  $r$ , a paraxial ray from  $Q$  will pass through  $P$  after reflection from the mirror; that is, the path of a ray of light that has undergone reflection, or refraction, can be reversed. Since the path of a light ray is reversible, all paraxial rays emitted from a source of light at  $Q$  will be brought to a focus at  $P$ . The points  $P$  and  $Q$  are therefore called *conjugate points* of the mirror.

From Equation (38-1) we note that when the source  $P$  is infinitely distant from the mirror, the image  $Q$  is located at a distance  $R/2$  from the vertex. The light from  $P$  striking the mirror consists of a parallel beam. From the discussion of Section 38-1, the point where a parallel beam, parallel to the principal axis, is brought to a focus is called the *principal focus* of the mirror. The image distance of an infinitely distant object, located on the principal axis, is called the *focal length*  $f$  of the mirror. Thus we find

$$f = R/2 \quad (38-2)$$

for the concave mirror, as indicated in Section 38-1.

It may be shown that Equations (38-1) and (38-2) are correct for all positions of the image and object of both concave and convex mirrors, provided that the following *sign conventions* are employed:

- (a) Light is assumed to come to the mirror from the left.

- (b) The distance  $s$  is positive when the object is to the left of the mirror.  
 (c) The distance  $s'$  is positive when the image is to the left of the mirror.  
 (d) The radius of curvature  $R$  and the focal length  $f$  are to be taken as positive for a concave mirror and negative for a convex mirror.  
 (e) The positive and negative signs are to be used *only* when numerical values are substituted for  $s$ ,  $s'$ ,  $f$ , and  $R$ .

We may examine the images of a finite object formed by a mirror by considering four particular rays from the object, called *principal rays*, chosen for their simplicity in graphical construction. In the imaging process, all rays from the object intersect at the image point. Consequently, the image point may be located by finding the intersection of any two rays after these have been reflected from the mirror. The principal rays generally chosen are: (a) a ray which is parallel to the principal axis, and which

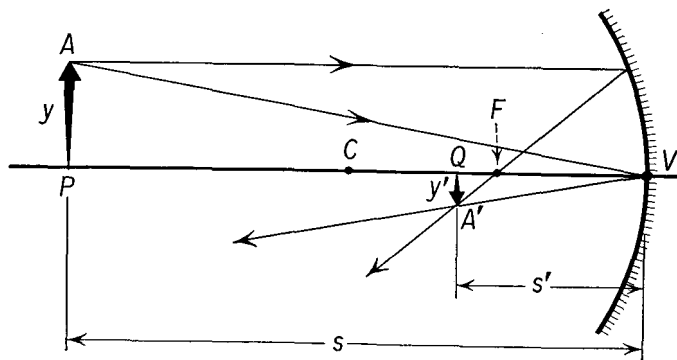

**Fig. 38-3** A real, inverted, smaller image is formed by a concave mirror when the object distance is greater than  $2f$ .

therefore must pass through the principal focus of the mirror after reflection (or, in the case of the convex mirror, which appears to diverge from the principal focus); (b) a ray which is directed toward the vertex of the mirror and is reflected as though the mirror is plane; (c) a ray which is directed toward the principal focus and which is reflected from the mirror parallel to the principal axis; (d) a ray which is directed to or from the center of curvature of the mirror, and hence strikes the mirror at normal incidence; this ray is reflected back along its incident path.

From Equation (38-1) we note that

$$\frac{1}{s'} = \frac{1}{f} - \frac{1}{s}.$$

As long as the object distance  $s$  is greater than the focal length  $f$  of a *concave* mirror, the image distance is positive. In the event that the object distance

is greater than  $2f$ , the image distance is less than  $2f$ , and the image is reduced in size, as shown in Figure 38-3. The position of the image  $A'$  of the head of the arrow at  $A$  is located by the use of a principal ray parallel to the principal axis and a second principal ray reflected from the vertex of the mirror. The image is smaller than the object and inverted. From the similar triangles  $AVP$  and  $A'VQ$  we note that the size of the image  $y'$  is to the image distance  $s'$  as the size of the object  $y$  is to the object distance  $s$ . We may define the linear or transverse *magnification*  $m$  of the system as

$$m = \frac{y'}{y}, \quad (38-3)$$

where we adopt the convention that the *distance*  $y$  (or  $y'$ ) is *positive above the axis and is negative below the axis*. From the figure, and the sign conventions on  $s$  and  $s'$ , we note that

$$m = -\frac{s'}{s}. \quad (38-4)$$

As before, the positive and negative signs associated with the sign conventions are to be used only when numerical values are substituted into the above equations. In the case illustrated in Figure 38-3, the magnification is negative, which means that the image is inverted, and the value of  $m$  is less than 1, which means that the image is smaller than the object.

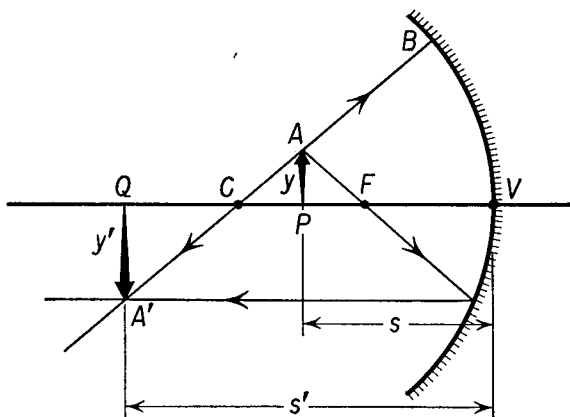

**Fig. 38-4** A real, inverted, enlarged image is formed by a concave mirror when the object is between  $C$  and  $F$ .

In Figure 38-4 we examine the case of an object which lies between the center of curvature and the focal point of the mirror. The principal rays used are the ray  $AB$ , which strikes the mirror normally and is reflected

back along its own path, and the ray  $AF$ , which passes through the focus  $F$  and is reflected parallel to the principal axis. These rays intersect in the point  $A'$ , the image of  $A$ . The image is real; it can be seen on a ground glass as the point where light rays actually intersect. The image  $A'Q$  is inverted and enlarged. The magnification is negative and greater than 1.

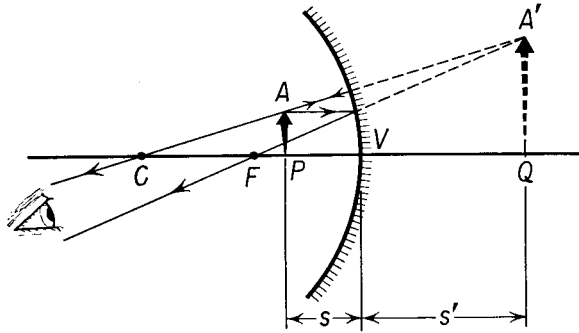

**Fig. 38-5** A virtual, enlarged image is formed by a concave mirror when the object distance is less than  $f$ .

Concave mirrors are often used as shaving mirrors to produce an erect, enlarged image. In Figure 38-5 we see that the image  $A'$  of a real object  $A$ , placed between the focal point and the vertex of the mirror, is enlarged and erect. The magnification is positive and greater than 1. Since the rays reflected from the mirror do not actually intersect but only appear to do so, as shown by the dotted lines, the image is virtual. An observer looking at the image  $A'$  sees rays which appear to diverge from  $A'$  and interprets this point as the origin of the rays. While the image can be seen, it cannot be focused on a ground glass, for rays from  $A$  do not converge to any point to the left of the mirror, which is the only region of space in which there is actually any light.

These relationships may all be calculated analytically by use of Equations (38-1) through (38-4) and by use of the sign conventions given above.

*Illustrative Example.* An object is placed 7.5 cm from a concave mirror whose focal length is 15 cm. Determine the position and character of the image.

The graphical solution is shown in Figure 38-5. We imagine the object to be to the left of the mirror. The object distance is  $s = 7.5$  cm, and the focal length is  $f = 15$  cm. We have

$$\begin{aligned}\frac{1}{s} + \frac{1}{s'} &= \frac{1}{f}, \\ \frac{1}{s'} &= \frac{1}{15} - \frac{1}{7.5} = -\frac{1}{15}, \\ s' &= -15 \text{ cm.}\end{aligned}$$

Thus the image is formed a distance of 15 cm to the right of the mirror. Since the image appears where there is no reflected light, the image is virtual. The magnification produced is

$$m = -\frac{s'}{s} = -\frac{-15}{7.5} = +2.$$

The image is erect and is twice the size of the object.

No matter where the object is placed in front of a *convex* mirror, its image will always be virtual, erect, and smaller than the object, as shown in Figure 38-6. A ray from  $A$  parallel to the axis is reflected back as though

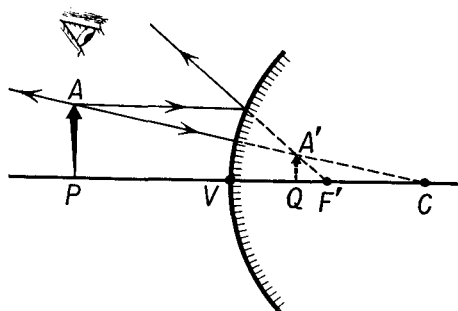

**Fig. 38-6** A virtual, erect, smaller image is formed by a convex mirror for any position of a real object.

it came from the virtual focus  $F'$ . A second principal ray, taken normal to the mirror, is reflected back on itself. These two rays do not meet but appear to have originated from the point  $A'$ , the virtual image of  $A$ . The image  $A'Q$  is virtual, erect, and smaller than the object.

*Illustrative Example.* An object is placed 45 cm in front of a convex mirror whose radius of curvature is 30 cm. Determine the position and character of the image.

Following the sign conventions indicated above, we have  $s = +45$  cm,  $f = R/2 = -15$  cm, and, substituting into the appropriate equation, we find

$$\begin{aligned}\frac{1}{s} + \frac{1}{s'} &= \frac{1}{f}, \\ \frac{1}{s'} &= -\frac{1}{15} - \frac{1}{45} = -\frac{4}{45}, \\ s' &= -11.25 \text{ cm.}\end{aligned}$$

The magnification is

$$m = -\frac{s'}{s} = -\frac{-11.25}{45} = +0.25.$$

The image is virtual and is situated 11.25 cm behind the mirror. Since the magnification is positive, the image is upright and, in this case, is one fourth the size of the object.



## 38-3 Lenses

Lenses, either singly, or in combination, are used for the formation of images and are made of a transparent material provided with spherical or plane surfaces. For certain special cases, other surfaces may be used to eliminate certain defects of spherical lenses, or to provide certain desired effects, but the great advantage of spherical surfaces is that they are easiest

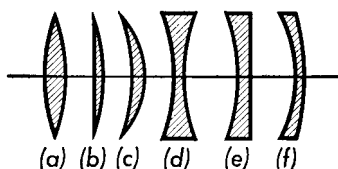

**Fig. 38-7** Spherical lenses: (a), (b), and (c) are converging lenses; (d), (e), and (f) are diverging lenses.

to make. Spherical lenses are classified as either *converging* or *diverging* lenses. Some common forms of lenses are shown in Figure 38-7, where we note that a converging lens is thicker at the center than at the edges, while a diverging lens is thinner at the center than at the edges.

**Fig. 38-8** Rays parallel to the principal axis are converged toward the principal focus  $F$  by the converging lens.

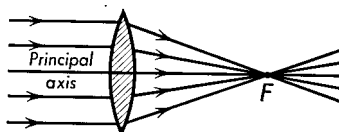

A beam of parallel light incident on a converging lens will be converged toward a point  $F$ , known as the *principal focus* of the lens, as shown in Figure 38-8. A beam of parallel light incident upon a diverging lens will

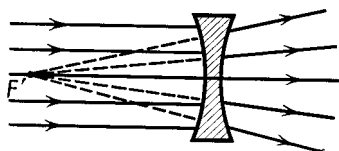

**Fig. 38-9** Rays parallel to the principal axis are diverged by the diverging lens. After passing through the lens the rays appear to come from the virtual focus at  $F'$ .

diverge after passing through the lens as though it came from  $F'$ , the principal focus, as shown in Figure 38-9. The point  $F'$  is called a virtual focus, since the rays do not actually pass through it.

The action of the lens is due to the refraction of the light as it enters and leaves the spherical surfaces bounding the lens. The effect of a converging lens on the plane wave fronts of a beam of parallel light is shown in Figure 38-10. The part of the wave front which passes through the center of the lens is retarded more than the part which passes through the

outer part of the lens, so that the emerging wave front is spherical, with its center at the principal focus  $F$ . Parallel wave fronts incident upon a

**Fig. 38-10** Change in wave front produced by a converging lens on a parallel beam of light incident upon the lens.

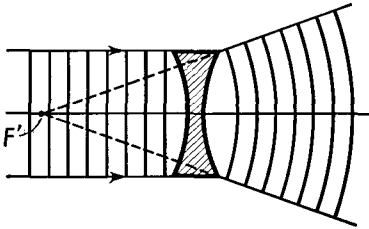
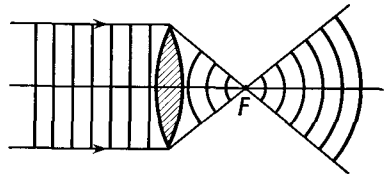

**Fig. 38-11** Change in wave front produced by a diverging lens on a parallel beam of light incident upon the lens.

diverging lens are retarded more at the thicker edge of the lens than at its center, and again the emergent wave front is spherical, with its center at  $F'$ , as shown in Figure 38-11.

### 38-4 Lensmaker's Formula

Let us consider the process of image formation in a thin, converging lens, as shown in Figure 38-12. We shall neglect the thickness of the lens and shall assume that the diameter of the lens is small in comparison with the radius of curvature of either surface, so that all angles with which we must deal may be approximated by their sines or tangents. For definiteness we shall study the image of an object point located on the principal axis of the lens, but none of the approximations made will depend upon this fact. Thus the object and image relationships that will be derived will be equally valid for pairs of conjugate points lying on any line parallel to the principal axis, and, just as in the case of mirrors, we shall find that points lying on a plane perpendicular to the principal axis, called the *object plane*, will be imaged on a second plane perpendicular to the principal axis, called the *image plane*. We shall assume that the lens is constructed of a medium of refractive index  $n$  and that the lens is immersed in air or vacuum.

Let us choose an arbitrary ray  $PA$  from the object  $P$  which strikes the lens at  $A$ . The line  $AC$  in Figure 38-12(b) is the normal to the front surface of the lens, and the refracted ray is in the direction  $AB$ . By making use of the theorem that the external angle of a triangle is equal to the sum of the two interior angles, we see from triangle  $ACP$  that

$$i_1 = \alpha_1 + \beta_1,$$

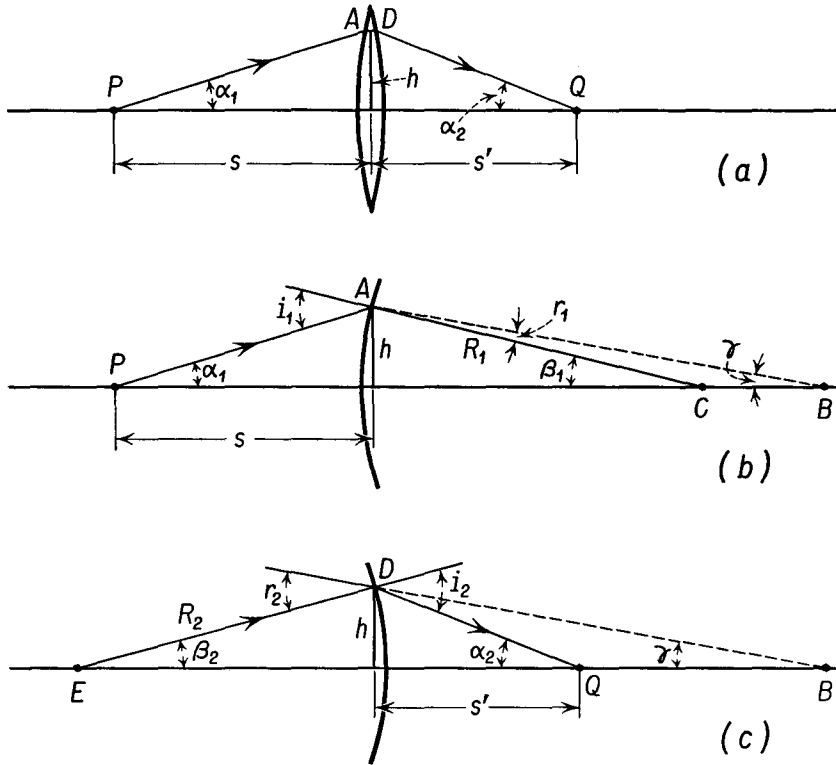

**Fig. 38-12** (a) Path of a ray of light through a thin lens. (b) Refraction at first surface. (c) Refraction at second surface.

and, from triangle  $ABC$  we find

$$r_1 = \beta_1 - \gamma.$$

For small angles Snell's law may be stated as

$$n = i/r,$$

so that

$$\alpha_1 + \beta_1 = n(\beta_1 - \gamma). \tag{38-5}$$

The refracted ray  $AB$  never really reaches the point  $B$  on the principal axis but, instead, is refracted at the second surface of the lens, at the point  $D$ , Figure 38-12(c), and intersects the principal axis at the point  $Q$ , the image of point  $P$ . The normal to the second surface of the lens is  $DE$ . From the figure we find from triangle  $DEQ$  that

$$i_2 = \beta_2 + \alpha_2,$$

while from triangle  $DEB$  we find that

$$r_2 = \beta_2 + \gamma.$$

For small angles we have  $n = i_2/r_2$ , so that

$$\beta_2 + \alpha_2 = n(\beta_2 + \gamma). \quad (38-6)$$

By eliminating  $\gamma$  from Equations (38-5) and (38-6), we find

$$\alpha_1 + \alpha_2 = (n - 1)(\beta_1 + \beta_2).$$

We make a number of approximations consistent with the idea of a thin lens of small diameter. Thus we say that the distance from  $A$  to the principal axis is very closely equal to the distance from  $D$  to the principal axis, and we label this distance  $h$ . The object distance  $s$  is the distance from  $P$  to the lens, and the image distance  $s'$  is the distance from  $Q$  to the lens, neglecting the thickness of the lens. We may approximate a small angle by either its sine or its tangent, so that  $\alpha_1 = h/s$ ,  $\alpha_2 = h/s'$ ,  $\beta_1 = h/R_1$ ,  $\beta_2 = h/R_2$ , and, substituting these relations into the above equation, we find

$$\frac{1}{s} + \frac{1}{s'} = (n - 1) \left( \frac{1}{R_1} + \frac{1}{R_2} \right). \quad (38-7)$$

We may find the principal focal length  $f$  of a thin lens by finding the image distance of an infinitely distant object. When  $s$  is infinity, we find  $s' = f$ , and from Equation (38-7)

$$\frac{1}{f} = (n - 1) \left( \frac{1}{R_1} + \frac{1}{R_2} \right). \quad (38-8)$$

Equation (38-8) is called the *lensmaker's equation*. We may write Equation (38-7) as

$$\boxed{\frac{1}{s} + \frac{1}{s'} = \frac{1}{f}}. \quad (38-9)$$

It may be shown that Equations (38-7), (38-8), and (38-9) are applicable to all thin lenses, through the use of the following *sign conventions*:

(a) The radius of curvature  $R$  is positive for a convex surface and negative for a concave surface.

(b) Light is assumed to come to the lens from the left.

(c) The object distance  $s$  is positive when the object is to the left of the lens.

(d) The image distance  $s'$  is positive when the image is to the right of the lens.

(e) The focal length  $f$  is positive for a converging lens and negative for a diverging lens.

(f) The positive and negative signs are to be used only when numerical values are substituted for the symbols.

The above equations were derived on the assumption that the lens was in air or vacuum and that  $n$  was the absolute index of refraction of the material of the lens. The equations are also correct when the lens is immersed in any medium, provided that  $n$  is interpreted as the relative index of refraction of the material of the lens with respect to the medium.

Just as in the case of mirrors, we may define the transverse magnification  $m$  of a lens by the equation

$$m = \frac{y'}{y}, \quad (38-10)$$

where  $y$  is the transverse dimension of the object, and  $y'$  is the transverse dimension of the image, taken positive as above the axis and negative below the axis. In terms of the object and image distances, this equation may be rewritten as

$$m = -\frac{s'}{s}. \quad (38-11)$$

### 38-5 Image Formation by Thin Lenses

We may examine the images formed in a lens by considering three *principal rays*, chosen for their simplicity in construction. In the imaging process, all rays from the object intersect at the image point, so that the image point may be located by finding the intersection of any two rays after they have passed through the lens. The principal rays generally chosen are: (a) a ray which is parallel to the principal axis, which must pass through the principal focus of a converging lens after refraction (or, in the case of a diverging lens the ray must diverge from the principal focus); (b) a ray which is directed toward the principal focus of the lens, and which is refracted by the lens so as to emerge parallel to the principal axis; and (c) a ray which is directed toward the center of the lens and passes through the lens undeviated, for the section of the lens at its center may be approximated as a plane parallel plate of negligible thickness.

The types of images formed by a *converging* lens may be determined with the aid of Equation (38-9),

$$\frac{1}{s} + \frac{1}{s'} = \frac{1}{f}.$$

We note that as long as  $s$  is greater than  $f$ , the image distance will be positive, and the image will be formed to the right of the lens. Figure 38-13 shows an object  $AB$  located a distance from a converging lens greater than  $2f$ . The image  $A'$  of the head  $A$  of the arrow is located by means of a ray parallel to the principal axis and a ray passing through the center of the lens. It is observed that the image is smaller than the object, inverted, and

real. The image can be seen by looking along the axis from a point beyond the image, or the image may be formed on a screen at the location of  $A'B'$  and then viewed from any convenient position as a result of the light scattered by the diffuse screen.

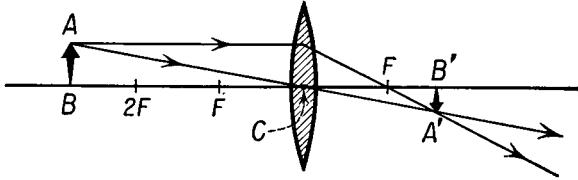

**Fig. 38-13** Image formed by a converging lens when the object distance is greater than  $2f$ .

In the event that the object distance  $s$  lies between  $f$  and  $2f$ , the image distance  $s'$  is greater than the object distance. The image is real, inverted, and is larger than the object, as shown in Figure 38-14.

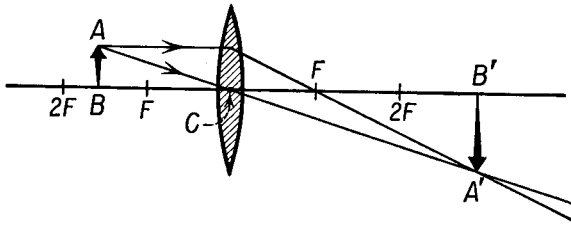

**Fig. 38-14** Real, enlarged image formed by a converging lens when the object distance is greater than  $f$  and less than  $2f$ .

When the object distance is smaller than  $f$ , we see that the image distance is negative. As shown in Figure 38-15, the rays from  $A$  do not

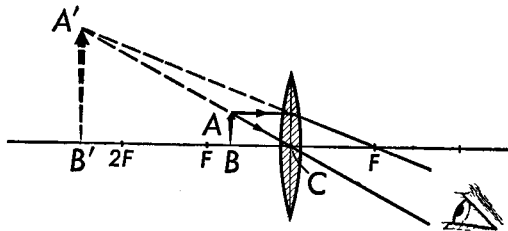

**Fig. 38-15** Virtual, enlarged image formed by a converging lens when the object distance is less than  $f$ .

meet after passing through the lens, but when projected back through the lens, the refracted rays, when seen by the eye, appear to have originated

from the point  $A'$ , on the same side of the lens as the object. The image in this case is virtual, erect, and is larger than the object. The virtual image cannot be formed on a ground glass but can be seen by looking through the lens.

*Illustrative Example.* An object 6 cm tall is situated 45 cm from a converging lens of 15 cm focal length. Determine the position, size, and nature of the image.

This problem is illustrated in the ray diagram of Figure 38-13. The object distance is  $s = +45$  cm, and the focal length is  $+15$  cm. We find

$$\frac{1}{s} + \frac{1}{s'} = \frac{1}{f},$$

and, substituting numerical values,

$$\frac{1}{s'} = \frac{1}{15} - \frac{1}{45} = \frac{2}{45},$$

$$s' = 22.5 \text{ cm.}$$

To find the size of the image

$$m = \frac{y'}{y} = -\frac{s'}{s}.$$

Since  $y = 6$  cm, we find

$$y' = -y \frac{s'}{s} = -6 \text{ cm} \times \frac{22.5 \text{ cm}}{45 \text{ cm}} = -3 \text{ cm.}$$

The image is real, for  $s'$  is positive, and is inverted and half the size of the object.

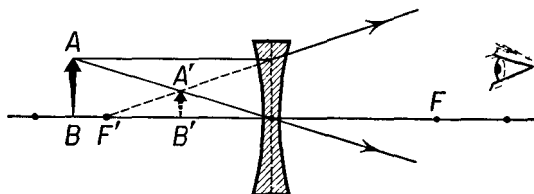

Fig. 38-16 Virtual image formed by a diverging lens.

The formation of an image by a *diverging* lens is illustrated in Figure 38-16. The rays from  $A$  diverge after passing through the lens and do not meet on the right-hand side of the lens. The rays appear to originate in the point  $A'$ , the virtual image of  $A$ . A diverging lens cannot form a real image of a real object. In Equation (38-9) we note that the focal length of a diverging lens is negative, so that the image distance  $s'$  is negative for all positive values of the object distance  $s$ .

*Illustrative Example.* An object is placed 25 cm in front of a diverging lens of 15 cm focal length. Find the position and character of the image.

An optical diagram of the system is shown in Figure 38-16. We have  $s = +25$  cm,  $f = -15$  cm, and

$$\frac{1}{s'} = -\frac{1}{15} - \frac{1}{25},$$

$$s' = -9.4 \text{ cm.}$$

The magnification produced is

$$m = -\frac{s'}{s} = -\frac{-9.4}{25} = +0.38.$$

The image is virtual, erect, and reduced with respect to the object.

### 38-6 Combinations of Lenses

Two or more lenses are frequently used in combination to produce a desired result. We may treat the effect of the lenses sequentially, first determining the image formed by the first lens of the combination, then using the image of the first lens as the object of the second lens, and so on. If two thin lenses are placed in contact, so that their principal axes coincide, the combination may be treated as a single lens of focal length  $f$  such that

$$\frac{1}{f} = \frac{1}{f_1} + \frac{1}{f_2}. \quad (38-12)$$

We may easily obtain this result by writing Equation (38-9) twice, once for lens 1 and once for lens 2, and adding these equations, as

$$\frac{1}{s_1} + \frac{1}{s_2} + \frac{1}{s_1'} + \frac{1}{s_2'} = \frac{1}{f_1} + \frac{1}{f_2}.$$

If the lenses are sufficiently thin so that we may neglect their thickness, we note that the numerical value of the image distance  $s_1'$  is the same as the numerical value of the object distance of the second lens  $s_1$ , but that the image distance of the first lens has an opposite sign from the object distance of the second lens. These two terms cancel, and we have

$$\frac{1}{s_1} + \frac{1}{s_2} = \frac{1}{f_1} + \frac{1}{f_2}.$$

Since the lenses are thin, there is no longer any need to use subscripts to distinguish the object and image distances, and, comparing the above equation with Equation (38-9), we note that the quantity on the right is the effective focal length of the combination of lenses, as given in Equation (38-12), and that the two-lens combination may be replaced by a single



lens of focal length  $f$ , in accordance with this equation. This result is often used by oculists in fitting eyeglasses. The focal length of the required correction lens is determined by placing a variety of thin lenses in contact before the patient's eye and computing the focal length of the combination from Equation (38-12).

*Illustrative Example.* An object is placed 14 cm in front of a converging lens of 10 cm focal length. Another converging lens of 7 cm focal length is placed at a distance of 40 cm to the right of the first lens. Determine the position and character of the final image.

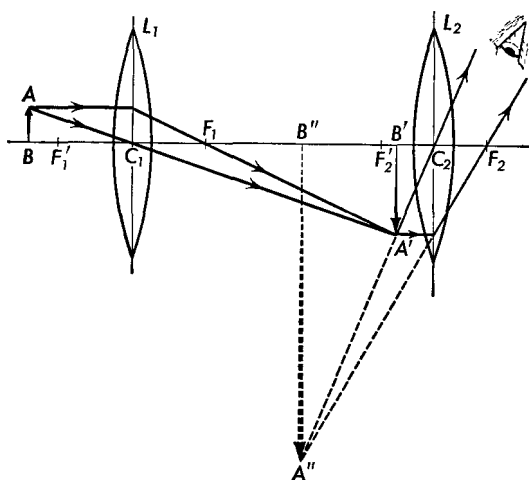

Fig. 38-17

The graphical solution is shown in Figure 38-17. The image produced by the first lens is  $A'B'$  which is real, inverted, and larger than the object. This is used as the object of the second lens. To find the image in the second lens, we again use a principal-ray construction, with  $A'B'$  as an object for the second lens. This is only a convenience in locating the image, for we do not infer that the light rays are suddenly deviated at the point  $A'$ . The final image is  $A''B''$ , which is virtual, larger than  $A'B'$ , and erect with respect to it. Thus the final image is inverted, with respect to the original object, and is virtual.

We can solve the problem by two successive applications of the lens equation. For the first lens  $L_1$ ,  $f_1 = 10$  cm, and  $s_1 = 14$  cm, so that

$$\frac{1}{s'_1} = \frac{1}{10} - \frac{1}{14},$$

$$s'_1 = 35 \text{ cm.}$$

Since the two lenses are 40 cm apart, the image  $A'B'$  is 5 cm from the second

lens  $L_2$ . Using  $A'B'$  as the object for the second lens,  $s_2' = 5$  cm,  $f_2 = 7$  cm, and we find

$$s_2'' = -17.5 \text{ cm};$$

that is, the final image is 17.5 cm to the left of the second lens and is virtual.

Since the second lens magnifies the image produced by the first lens, the total magnification of the system is the product of the magnification  $m_1$  of the first lens by the magnification  $m_2$  of the second lens; that is,

$$m = m_1 m_2 = \frac{s_1'}{s_1} \times \frac{s_2'}{s_2},$$

or

$$m = -\frac{35}{14} \times \frac{17.5}{5} = -8.75.$$

The negative sign shows that the final image is inverted with respect to the original object  $AB$ .

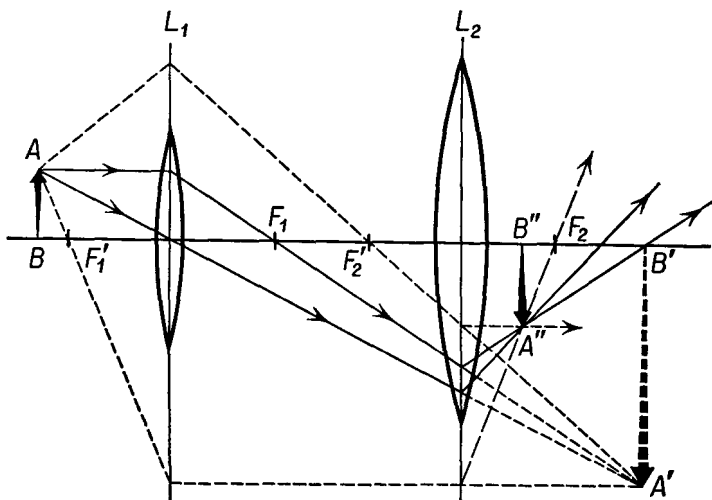

Fig. 38-18

*Illustrative Example.* Two converging lenses  $L_1$  and  $L_2$  are placed 40 cm apart, their principal axes coinciding. An object  $AB$  is placed 15 cm in front of  $L_1$ . The focal length of  $L_1$  is 12 cm, and the focal length of  $L_2$  is 10 cm. Determine the position and character of the final image.

The graphical solution is shown in Figure 38-18. Principal rays from the object  $AB$  would have intersected at the image  $A'B'$  had they not been intercepted by the lens  $L_2$ . For purposes of construction, we may imagine the lenses  $L_1$  and  $L_2$  to be of any diameter. If the lens  $L_1$  were sufficiently large, there would have been rays through  $L_1$  to the point  $A'$  in many different directions. Thus there would have been a ray from  $A$  through  $L_1$  to  $A'$  parallel to the principal axis. Another possible ray from  $A$  through  $L_1$  to  $A'$  might pass

through the center of lens  $L_2$ . The second of these rays passes undeviated through  $L_2$ , while the first must pass through the principal focus  $F_2$  of  $L_2$  after passing through this lens. A third possible ray from  $A$  through  $L_1$  to  $A'$  might have passed through  $F'_2$  and, upon passage through the lens  $L_2$ , would have been deflected parallel to the principal axis. We draw two of these rays and locate the final image by their point of intersection as  $A''B''$ .

The object for lens  $L_2$  is the image  $A'B'$  formed by lens  $L_1$ ; it is a *virtual object* for lens  $L_2$ , for the rays striking  $L_2$  are converging toward  $A'B'$  rather than diverging from it.

Analytically, we find

$$\frac{1}{s'_1} = \frac{1}{12} - \frac{1}{15},$$

$$s'_1 = 60 \text{ cm.}$$

Thus  $A'B'$  is 20 cm to the right of lens  $L_2$ , and, by our sign convention, the object distance for the second lens is  $s_2 = -20$  cm. The position of the image formed by  $L_2$  may be found from

$$\frac{1}{s'_2} = \frac{1}{10} - \frac{1}{-20},$$

$$s'_2 = 6.7 \text{ cm;}$$

that is, the final image is 6.7 cm to the right of  $L_2$ . The magnification produced by this combination of lenses is

$$m = \frac{s'_1}{s_1} \times \frac{s'_2}{s_2} = \frac{60}{15} \times \frac{6.7}{-20} = -1.34.$$

The negative sign shows that the final image is inverted with respect to the original object.

### 38-7 Spherical Aberration of Lenses and Mirrors

In the discussion of spherical mirrors, it was stated that the mirror should be a small portion of the sphere. If the mirror surface is a large portion of the sphere, the images are blurred. This blurring of the image is due to *spherical aberration*; that is, rays from one point of the object reflected by different portions of the spherical surface do not meet in a point but cover a sizable area. When a beam of parallel rays is incident upon a large mirror, the reflected rays do not all pass through the principal focus, as shown in Figure 38-19. The rays which are reflected from the outer portion of the mirror cross the principal axis closer to the mirror than do those which are reflected from the central portion. Instead of a sharp point, there is a sizable focal spot.

A sharp focus of light parallel to the principal axis can be obtained with a large mirror if the surface is parabolic in shape instead of spherical. It is a property of a parabola that any ray from the focus which strikes the

parabolic surface is reflected parallel to the principal axis, as shown in Figure 38-20. If a very small source of light is placed at the focus, a parallel beam is reflected from parabolic mirrors; this is another illustration of the reversibility of the paths of rays of light. Parabolic mirrors are commonly used in automobile head lamps and in searchlights. The very

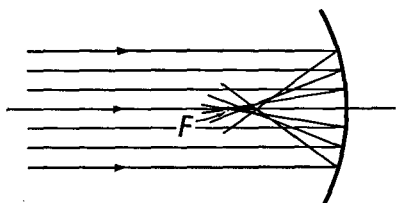

**Fig. 38-19** Spherical aberration produced by a mirror.

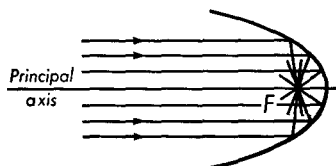

**Fig. 38-20** A beam of light parallel to the principal axis is focused in a point by a parabolic mirror.

large astronomical telescopes are reflectors, using parabolic mirrors. Parabolic mirrors are best used in cases in which the incident or emergent light is parallel to the principal axis of the mirror, for these mirrors show aberrations when the image and object are off the principal axis.

The images formed by lenses also show spherical aberration. These aberrations are most clearly indicated by the use of monochromatic light, such as the yellow light from a sodium lamp. A set of parallel rays of

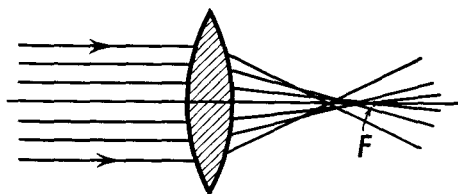

**Fig. 38-21** Spherical aberration of a lens.

monochromatic light parallel to the principal axis of a lens is brought to a focus in a blurred spot, as shown in Figure 38-21, the amount of blurring depending upon the diameter of the lens. The rays passing through the outer portion of the lens are deviated so that they cross the principal axis closer to the lens than do the rays passing through the center portion. One way of reducing spherical aberration is to use a diaphragm to limit the light from the object to the central portion of the lens.

It must be emphasized that accurate lenses are not designed by use of the lensmaker's formula. Practical lenses are complex combinations of several different lens elements, combined to minimize spherical aberration and other aberrations which will not be discussed here. In many cases the lens designer finds it necessary to trace rays through the optical system

by use of Snell's law, and must consider skew rays as well as paraxial rays in order to assure a sharp image.

### 38-8 Chromatic Aberration

From the lensmaker's equation we note that the focal length of a lens depends upon its refractive index. Most transparent substances are dispersive media and thus have different refractive indices at different wavelengths. Thus, when white light is incident upon a lens, the red component

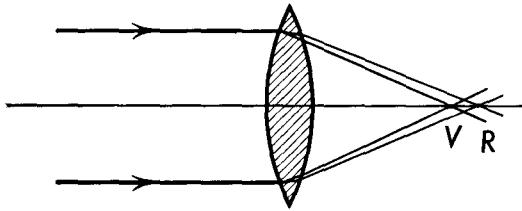

Fig. 38-22 Chromatic aberration of a lens.

of the light will be focused farthest from the lens, while violet light will be focused closest to the lens, as shown in Figure 38-22. The image of a lamp focused by a lens on a screen will be observed to have a colored halo.

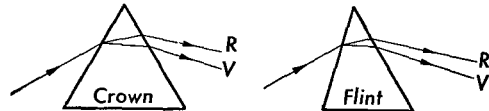
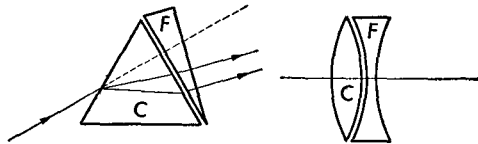

Fig. 38-23 The design of an achromatic lens.



Lenses used for visual or photographic purposes must be corrected so as to minimize this *chromatic aberration*.

In some special cases lenses may be achromatized by use of two converging lenses of the same kind of glass, as in the case that either the incident or emergent light is a parallel beam. In this case the separation between the lenses must be half the sum of the focal lengths of the two lenses. Ramsden and Huygens eyepieces used with telescopes and microscopes are built in this way (see Section 39-4). In general, lenses are achromatized by use of elements constructed from different kinds of glass. The basic idea in the design of such an achromatic lens is illustrated in Figure 38-23, which shows light passing through a prism of crown glass and

a prism of flint glass. The prism angles have been so chosen that the prisms deviate the light differently, but the angular width of the spectrum, or the dispersion, is the same in both cases. When these two prisms are placed in contact with their vertex angles opposed, the prism combination produces a deviated beam of white light, which is not dispersed, for the dispersion of one prism has been compensated by the dispersion of the second prism. A converging achromatic lens combination can therefore be made by combining a crown-glass lens of short positive focal length with a flint-glass lens of longer negative focal length. These may be cemented together to form a single achromatic lens.

### 38-9 Illuminance of an Image

In all optical systems the amount of light reaching the image is an extremely important consideration. We have already indicated in Section 36-5 that the luminance, or brightness, of a source, rather than its luminous flux

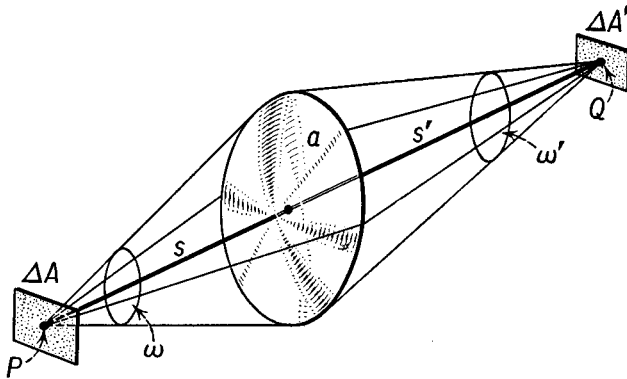

Fig. 38-24

output, determines the illuminance. Let us consider the formation of an image by a simple lens, as shown in Figure 38-24. Let us suppose that the magnification of the system is  $m$ . Then an element of area  $\Delta A$  of the source is imaged in an element of area  $\Delta A'$  on the image, such that

$$\frac{\Delta A'}{\Delta A} = m^2. \quad (38-13)$$

Let us assume that all the light emitted by the source which strikes the lens from  $\Delta A$  is imaged upon  $\Delta A'$ ; that is, there is no absorption or reflection from the lens surfaces. If  $\omega$  is the solid angle subtended by the lens from the source, the luminous flux  $F$  which passes into the lens from  $\Delta A$  is given by

$$F = B \Delta A \omega,$$

where  $B$  is the luminance or brightness of the source, expressed in lumens per square centimeter per steradian. The illuminance  $E$  of the image is the incident flux per unit area, or

$$E = \frac{F}{\Delta A'} = \frac{B \Delta A \omega}{\Delta A'},$$

or, substituting from Equation (38-13),

$$E = \frac{B\omega}{m^2}. \quad (38-14)$$

Thus the frontal area of the lens (as it influences  $\omega$ ) and the brightness of the source determine the brightness of the image. For a given object distance, the greater the magnification, the smaller is the illuminance of the image. If  $a$  represents the frontal area of the lens, the solid angle subtended by the lens at the source is  $\omega = a/s^2$ , while the solid angle  $\omega'$  subtended by the lens at the position of the image is  $\omega' = a/(s')^2$ . Thus

$$\omega = \omega' \frac{(s')^2}{s^2} = \omega' m^2.$$

Substituting this relationship into Equation (38-14), we find

$$E = B\omega'. \quad (38-15)$$

Thus the illuminance of the image depends upon the brightness of the source and upon the solid angle subtended by the lens at the position of the image. The brightness of the source rather than its luminous output determines the brightness of the image.

It is a common misconception that searchlights produce a bundle of parallel rays extending to infinity. Such might be the case with point sources of light at the focal point, but practical sources are extended sources rather than point sources. Portions of the source which do not lie at the focal point, or on the axis, produce bundles of rays which are not parallel to the axis. The illumination of a point on the axis of a searchlight varies inversely with the square of the distance from the source, in accordance with Equation (38-15). The size of the source does not affect the illumination produced on the axis of the searchlight. It is for this reason that carbon arcs are used in high-intensity searchlights as well as in commercial motion-picture projection systems.

### Problems

38-1. An object is placed 20 cm from a concave spherical mirror whose radius is 24 cm. Determine algebraically and graphically the position of the image. Describe the image.

38-2. An object 4 cm long is placed 60 cm from a concave spherical mirror whose radius of curvature is 40 cm. Determine (a) the position and (b) the size of the image. (c) Describe the image. (d) Draw a ray diagram.

38-3. An object 3 cm long is placed 4 cm from a concave spherical mirror whose focal length is 12 cm. Determine (a) the position of the image and (b) the magnification. (c) Describe the image. (d) Draw a ray diagram.

38-4. An object 6 cm long is placed 20 cm in front of a convex spherical mirror whose focal length is 24 cm. Determine (a) the position and (b) the size of the image. (c) Describe the image. (d) Draw a ray diagram.

38-5. A concave spherical mirror has a radius of curvature of 50 cm. A square object 3 cm on an edge is placed 10 cm in front of the mirror. Determine (a) the position of the image and (b) the area of the image.

38-6. A plane mirror is separated from a concave mirror of 50 cm radius by a distance of 100 cm. A burning candle is placed between them 20 cm from the spherical mirror. (a) Where is the image of the candle in the plane mirror? Is it real or virtual? (b) Where is the image of the candle in the spherical mirror? Is it real or virtual? (c) The plane mirror forms an image of the image in the spherical mirror found in Part (b). Where is this image? Is it real or virtual?

38-7. An object 2 cm long is placed 32 cm in front of a converging lens whose focal length is 20 cm. Find (a) the position and (b) the size of the image. (c) Describe the image. (d) Draw a ray diagram.

38-8. An object 6 cm long is placed 60 cm in front of a converging lens whose focal length is 90 cm. Find (a) the position of the image, (b) the magnification, and (c) the size of the image. (d) Describe the image. (e) Draw a ray diagram.

38-9. A convenient approximate method for obtaining the focal length of a converging lens is to measure the image distance for a distant object. What percentage error would be made if the distant object used was the window of the laboratory, about 6 m from a lens of focal length 10 cm?

38-10. An object 5 cm long is placed 20 cm in front of a diverging lens whose focal length is  $-10$  cm. Find (a) the position and (b) the size of the image. (c) Describe the image. (d) Draw a ray diagram.

38-11. An illuminated object and screen are 6 m apart. A converging lens is placed between them so that a real image 15 times the length of the object is formed on the screen. (a) Determine the distance of the lens from the object. (b) Determine the focal length of the lens.

38-12. A lens placed 40 cm from an object forms a real inverted image 16 cm from the lens. (a) What is the focal length of the lens? (b) Draw a ray diagram.

38-13. Two thin converging lenses, each of 10 cm focal length, are spaced 15 cm apart, their principal axes coinciding. An object 6 cm long is placed 20 cm in front of the first lens. (a) Determine the position of the image in the first lens. (b) Determine the position of the final image. (c) Determine the over-all magnification. (d) Is the image real or virtual? (e) Draw a ray diagram for the system.

38-14. An object is placed 40 cm from a thin converging lens of 8 cm focal



length. A second thin converging lens of 12 cm focal length is placed 20 cm behind the first lens. (a) Determine graphically and algebraically the position of the final image. (b) Determine the magnification produced by this lens combination.

38-15. An object is placed 16 cm from a thin converging lens of 32 cm focal length. A second thin converging lens of 6 cm focal length is placed 20 cm behind the first lens. (a) Determine graphically and algebraically the position of the final image. (b) Determine the magnification.

38-16. A converging lens forms an image on a screen 60 cm from it. A thin diverging lens is interposed between them at a distance of 40 cm from the converging lens. It is now found necessary to move the screen 10 cm away from the lens in order to produce a sharp image. Determine the focal length of the diverging lens.

38-17. A carbon arc is to be focused on a screen 10 m from the arc by means of a lens of frontal diameter 2 cm and of focal length 5 cm. (a) Find the position of the lens. (b) Using data furnished in Table 36-1 for a 1,500-watt carbon arc, find the illuminance of the screen.

38-18. Repeat Problem 38-17 for a lens of 20 cm focal length and frontal diameter 2 cm. Does the lens of long or short focal length provide the brighter image when the positions of the arc and screen are fixed?