

University of Nebraska - Lincoln

DigitalCommons@University of Nebraska - Lincoln

Nebraska Tractor Tests

Tractor Test and Power Museum, The Lester F.
Larsen

January 2007

Test 1916: Case-IH Magnum 275 Diesel 19-Speed (Chassis S/N Z7RZ05000 and Higher)

Tractor Museum

University of Nebraska-Lincoln, TractorMuseumArchives@unl.edu

Follow this and additional works at: <http://digitalcommons.unl.edu/tractormuseumlit>



Part of the [Applied Mechanics Commons](#)

Museum, Tractor, "Test 1916: Case-IH Magnum 275 Diesel 19-Speed (Chassis S/N Z7RZ05000 and Higher)" (2007). *Nebraska Tractor Tests*. 2092.

<http://digitalcommons.unl.edu/tractormuseumlit/2092>

This Article is brought to you for free and open access by the Tractor Test and Power Museum, The Lester F. Larsen at DigitalCommons@University of Nebraska - Lincoln. It has been accepted for inclusion in Nebraska Tractor Tests by an authorized administrator of DigitalCommons@University of Nebraska - Lincoln.

NEBRASKA OECD TRACTOR TEST 1916—SUMMARY 588

CASE IH MAGNUM 275 DIESEL

19 SPEED

Tractor chassis S/N Z7RZ05000 and higher

POWER TAKE-OFF PERFORMANCE

Power HP (kW)	Crank shaft speed rpm	Gal/hr (l/h)	lb/hp.hr (kg/kW.h)	Hp.hr/gal (kW.h/l)	Mean Atmospheric Conditions
MAXIMUM POWER AND FUEL CONSUMPTION					
Rated Engine Speed—(PTO speed—1109 rpm)					
229.22 (170.93)	2000	13.86 (52.47)	0.424 (0.258)	16.54 (3.26)	
Standard Power Take-off Speed (1000 rpm)					
271.30 (202.31)	1804	15.28 (57.80)	0.395 (0.240)	17.75 (3.50)	
Maximum Power (1 hour)					
271.58 (202.51)	1750	15.15 (57.36)	0.391 (0.238)	17.92 (3.53)	

VARYING POWER AND FUEL CONSUMPTION

229.22 (170.93)	2000	13.86 (52.47)	0.424 (0.258)	16.54 (3.26)	Air temperature
202.35 (150.89)	2080	13.46 (50.94)	0.466 (0.283)	15.04 (2.96)	77°F (25°C)
155.57 (116.01)	2131	12.56 (47.53)	0.566 (0.344)	12.39 (2.44)	Relative humidity
105.95 (79.00)	2180	9.55 (36.14)	0.631 (0.384)	11.10 (2.19)	14%
53.31 (39.75)	2215	6.44 (24.36)	0.846 (0.515)	8.28 (1.63)	Barometer
1.89 (1.41)	2244	3.84 (14.53)	14.196 (8.633)	0.49 (0.10)	29.30" Hg (99.22 kPa)

Maximum torque - 923 lb.-ft. (1251 Nm) at 1399 rpm

Maximum torque rise - 53.2%

Torque rise at 1599 engine rpm - 43%

Power increase at 1750 engine rpm - 18.5%

DRAWBAR PERFORMANCE UNBALLASTED - FRONT DRIVE ENGAGED FUEL CONSUMPTION CHARACTERISTICS

Power Hp (kW)	Drawbar pull lbs (kN)	Speed mph (km/h)	Crank- shaft speed rpm	Slip %	Fuel Consumption lb/hp.hr (kg/kW.h)	Hp.hr/gal (kW.h/l)	Temp. °F (°C) cool- ing med	Air dry bulb	Barom. inch Hg (kPa)
Maximum Power—9th Gear									
195.02 (145.43)	12694 (56.47)	5.76 (9.27)	1997	3.3	0.499 (0.304)	14.04 (2.77)	190 (88)	54 (12)	28.98 (98.14)
75% of Pull at Maximum Power—9th Gear									
155.31 (115.82)	9526 (42.37)	6.11 (9.84)	2095	2.2	0.582 (0.354)	12.04 (2.37)	191 (88)	59 (15)	28.95 (98.04)
50% of Pull at Maximum Power—9th Gear									
107.65 (80.28)	6391 (28.43)	6.32 (10.17)	2149	1.5	0.700 (0.426)	10.01 (1.97)	190 (88)	61 (16)	28.95 (98.04)
75% of Pull at Reduced Engine Speed—11th Gear									
155.56 (116.00)	9528 (42.38)	6.12 (9.85)	1594	2.2	0.503 (0.306)	13.93 (2.75)	187 (86)	61 (16)	28.95 (98.04)
50% of Pull at Reduced Engine Speed—11th Gear									
107.78 (80.37)	6446 (28.67)	6.27 (10.09)	1621	1.4	0.565 (0.344)	12.40 (2.44)	186 (86)	61 (16)	28.95 (98.04)

Location of tests: Nebraska Tractor Test Laboratory, University of Nebraska, Lincoln, Nebraska 68583-0832

Dates of tests: November 6 -14, 2007

Manufacturer: CNH America LLC, 700 State St. Racine, Wi. 53404 USA

FUEL, OIL and TIME: Fuel No. 2 Diesel Specific gravity converted to 60°/60°F (15°/15°C) 0.8417 Fuel weight 7.008 lbs/gal (0.840 kg/l) Oil SAE 15W40 API service classification CI-4 Transmission and hydraulic lubricant Case IH Hy-Tran Ultra fluid Front axle lubricant SAE 85W-140 API GL-5 Total time engine was operated: 26.0 hours

ENGINE: Make CNH Engine Corporation Diesel **Type** six cylinder vertical with turbocharger and air to air intercooler **Serial No.** *46750979* **Crankshaft** lengthwise **Rated engine speed** 2000 **Bore and stroke** 4.488" x 5.689" (114.0 mm x 144.5 mm) **Compression ratio** 17.6 to 1 **Displacement** 540 cu in (8849 ml) **Starting system** 12 volt **Lubrication** pressure **Air cleaner** two paper elements and aspirator **Oil filter** one full flow cartridge **Oil cooler** engine coolant heat exchanger for crankcase oil, radiator for hydraulic and transmission oil **Fuel filter** two paper elements **Fuel cooler** radiator for pump return fuel **Muffler** vertical **Cooling medium temperature control** 2 thermostats and variable speed fan

ENGINE OPERATING PARAMETERS: Fuel rate: 97.2-107.1 lb/h (44.1 - 48.6 kg/h) **High idle:** 2220-2260 rpm **Turbo boost:** nominal 21.0 - 25.4 psi (145 -175 kPa) as measured 24.1 psi (166 kPa)

CHASSIS: Type front wheel assist **Serial No.** *Z7RZ04360* **Tread width** rear 64.0" (1626 mm) to 129.0" (3277 mm) front 60.0" (1524 mm) to 88.0" (2235 mm) **Wheelbase** 118.3" (3005 mm) **Hydraulic control system** direct engine drive **Transmission** selective gear fixed ratio with full range operator controlled powershift **Nominal travel speeds mph (km/h)** first 1.97 (3.17) second 2.26 (3.64) third 2.60 (4.19) fourth 2.99 (4.81) fifth 3.43 (5.52) sixth 3.93 (6.33) seventh 4.59 (7.38) eighth 5.26 (8.47) ninth 6.06 (9.77) tenth 6.96 (11.20) eleventh 7.98 (12.85) twelfth 9.16 (14.74) thirteenth 11.41 (18.37) fourteenth 13.09 (21.07) fifteenth 15.10 (24.30) sixteenth 17.32 (27.87) seventeenth 19.87 (31.97) eighteenth 22.79 (36.67) nineteenth 24.86 (40.00) (1750 engine rpm) reverse 2.83 (4.56), 3.26 (5.24), 6.61 (10.63), 7.57 (12.19) **Clutch** multiple wet disc electrohydraulically operated by foot pedal **Brakes** wet disc hydraulically operated by two foot pedals that can be locked together **Steering** hydrostatic **Power take-off** 540 rpm at 1806 engine rpm or 1000 rpm at 1803 engine rpm **Unladen tractor mass** 21595 lb (9795 kg)

**DRAWBAR PERFORMANCE
UNBALLASTED - FRONT DRIVE ENGAGED
MAXIMUM POWER IN SELECTED GEARS**

Power Hp (kW)	Drawbar pull lbs (kN)	Speed mph (km/h)	Crank- shaft speed rpm	Slip %	Fuel Consumption lb/hp.hr (kg/kW.h)	Temp.°F (°C) cool- ing med	Barom. inch Hg (kPa)		
5th Gear									
170.97 (127.49)	20897 (92.95)	3.07 (4.94)	2033	11.1	0.561 (0.341)	12.49 (2.46)	191 (88)	46 (8)	29.00 (98.21)
6th Gear									
186.34 (138.95)	19608 (87.22)	3.56 (5.74)	1986	7.5	0.526 (0.320)	13.32 (2.62)	192 (89)	50 (10)	28.99 (98.17)
7th Gear									
204.57 (152.55)	19253 (85.64)	3.98 (6.41)	1905	7.3	0.501 (0.305)	13.99 (2.76)	191 (88)	52 (11)	28.98 (98.14)
8th Gear									
220.98 (164.79)	18636 (82.89)	4.45 (7.16)	1832	6.1	0.481 (0.293)	14.56 (2.87)	192 (89)	53 (12)	28.98 (98.14)
9th Gear									
226.79 (169.11)	17169 (76.37)	4.95 (7.97)	1755	5.3	0.466 (0.283)	15.04 (2.96)	191 (88)	55 (13)	28.97 (98.10)
10th Gear									
231.44 (172.58)	15131 (67.30)	5.74 (9.23)	1749	4.2	0.455 (0.277)	15.39 (3.03)	191 (88)	55 (13)	28.97 (98.10)
11th Gear									
229.85 (171.40)	12933 (57.53)	6.67 (10.73)	1757	3.4	0.461 (0.280)	15.21 (3.00)	191 (88)	55 (13)	28.97 (98.10)
12th Gear									
229.15 (170.88)	11191 (49.78)	7.68 (12.36)	1755	2.8	0.464 (0.282)	15.12 (2.98)	191 (88)	56 (13)	28.97 (98.10)
13th Gear									
228.38 (170.30)	8873 (39.47)	9.65 (15.53)	1756	2.1	0.464 (0.282)	15.10 (2.97)	190 (88)	57 (14)	28.97 (98.10)

REPAIRS AND ADJUSTMENTS: No repairs or adjustments.

NOTE: The performance figures on this report apply to tractors with chassis S/N Z7RZ05000 and higher.

REMARKS: All test results were determined from observed data obtained in accordance with official OECD, SAE and Nebraska test procedures. For the maximum power tests the fuel temperature at the primary fuel filter was maintained at 113°F (45°C). The manufacturer's claims of 59 GPM(223 lpm) and 75 GPM(282 lpm) remote hydraulic flow were not verified. The pull in 3rd gear (ballasted tractor) was limited to avoid excessive tractor bouncing. The performance results on this summary were taken from OECD tests conducted under the Code II Test Code Procedure.

We, the undersigned, certify that this is a true and correct report of official Tractor Test No. **1916**, Nebraska Summary 588, December 17, 2007

Roger M. Hoy
Director

M.F. Kocher
V.I. Adamchuk
J.A. Smith
Board of Tractor Test Engineers

TRACTOR SOUND LEVEL WITH CAB dB(A)

At no load in 7th gear	69.2
Bystander in 18th gear	87.7

TIRES, BALLAST AND WEIGHT

	With Ballast	Without Ballast
Rear Tires -No., size, ply & psi (kPa)	Four 520/85R42;**,11(75)	Two 520/85R42;**,16(110)
Ballast - Duals (total)	1950 lb (885 kg)	None
- Cast Iron (total)	4085 lb (1852 kg)	None
Front Tires -No., size, ply & psi (kPa)	Four 420/90R30;**,10(70)	Two 420/90R30;**,16(110)
Ballast - Duals (total)	1030 lb (467 kg)	None
- Cast Iron (total)	1550 lb (703 kg)	None
Height of Drawbar	18.0 in (455 mm)	17.0 in(430 mm)
Static Weight with operator - Rear	18520 lb (8400 kg)	13115 lb(5949 kg)
- Front	11865 lb (5382 kg)	8655 lb(3926 kg)
- Total	30385 lb(13782 kg)	21770 lb(9875 kg)

DRAWBAR PERFORMANCE
BALLASTED - 1750 ENGINE RPM
MAXIMUM POWER IN SELECTED GEARS

Power Hp (kW)	Drawbar pull lbs (kN)	Speed mph (km/h)	Crank- shaft speed rpm	Slip %	Fuel Consumption lb/hp.hr (kg/kW.h)	Consumption Hp.hr/gal (kW.h/l)	Temp. °F (°C) cool- ing med	Air dry bulb	Barom. inch Hg (kPa)
3rd Gear									
181.51 (135.55)	30422 (135.32)	2.24 (3.60)	1975	11.2	0.543 (0.331)	12.90 (2.54)	192 (89)	50 (10)	28.91 (97.90)
4th Gear									
199.51 (148.78)	28985 (128.93)	2.58 (4.15)	1918	8.4	0.510 (0.310)	13.75 (2.71)	191 (88)	51 (11)	28.92 (97.93)
5th Gear									
216.51 (161.45)	28896 (128.54)	2.81 (4.52)	1807	8.1	0.492 (0.299)	14.24 (2.81)	191 (88)	51 (11)	28.92 (97.93)
6th Gear									
222.25 (165.73)	25988 (115.60)	3.21 (5.16)	1754	5.3	0.475 (0.289)	14.76 (2.91)	190 (88)	52 (11)	28.92 (97.93)
7th Gear									
229.75 (171.33)	22705 (101.00)	3.79 (6.11)	1752	3.6	0.460 (0.280)	15.25 (3.00)	191 (88)	52 (11)	28.92 (97.93)
8th Gear									
230.08 (171.57)	19678 (87.53)	4.38 (7.06)	1751	2.8	0.459 (0.279)	15.27 (3.01)	190 (88)	53 (12)	28.92 (97.93)
9th Gear									
234.26 (174.69)	17294 (76.93)	5.08 (8.18)	1751	2.4	0.450 (0.274)	15.57 (3.07)	190 (88)	53 (12)	28.93 (97.97)
10th Gear									
231.67 (172.76)	14835 (65.99)	5.86 (9.43)	1752	2.1	0.456 (0.278)	15.35 (3.02)	185 (85)	54 (12)	28.93 (97.97)
11th Gear									
227.05 (169.31)	12610 (56.09)	6.75 (10.87)	1756	1.7	0.466 (0.284)	15.03 (2.96)	190 (88)	54 (12)	28.94 (98.00)
12th Gear									
223.88 (166.95)	10824 (48.15)	7.76 (12.48)	1754	1.5	0.472 (0.287)	14.85 (2.93)	190 (88)	54 (12)	28.94 (98.00)
13th Gear									
219.53 (163.70)	8491 (37.77)	9.70 (15.60)	1754	1.1	0.478 (0.291)	14.66 (2.89)	190 (88)	54 (12)	28.95 (98.04)

THREE POINT HITCH PERFORMANCE(OECD Static Test)

CATEGORY: III

Quick Attach: Yes

		High Lift Option
Maximum force exerted through whole range:	15183 lb (67.5 kN)	17931 lb (79.8 kN)
	38.6 GPM pump	44.0 GPM pump
i) Sustained pressure at compensator cutoff:	3128 psi (216 bar)	3156 psi (218 bar)
ii) Pump delivery rate at minimum pressure and rated engine speed:	39.2 GPM (148.4 l/min)	44.1 GPM (167.1 l/min)
iii) Pump delivery rate at maximum hydraulic power:	38.3 GPM (145.0 l/min)	43.2 GPM (163.3 l/min)
Delivery pressure:	2853 psi (197 bar)	2957 psi (204 bar)
Power:	63.8 HP (47.5 kW)	74.4 Hp (55.5 kW)

HITCH DIMENSIONS AS TESTED—NO LOAD

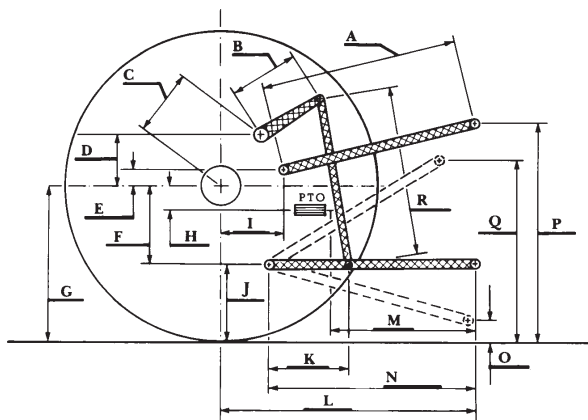

	inch	mm
A	28.2	718
B	20.5	520
C	22.9	581
D	20.7	525
E	10.5	266
F	15.7	400
G	36.4	925
H	3.5	90
I	20.9	530
J	20.7	525
K	30.2	768
L	46.1	1170
*L'	50.7	1287
M	20.1	511
N	38.2	970
O	9.0	230
P	47.6	1210
Q	40.7	1035
R	39.2	995

*L' to Quick Attach ends



CASE IH MAGNUM 275 DIESEL