

Surface Awareness

by Evan Gunn

A Terminal Project
Presented to the Faculty of
The College of Architecture at the University of Nebraska
In Partial Fulfillment of Requirements
For the Degree of Master of Architecture

Major: Architecture
Under the Supervision of
Associate Professor Jeffrey L. Day
Lincoln, Nebraska
May, 2008

Table of Contents

Abstract	3
Idea Intentions	4
Digital Making of Buildings	6
Digital Fabrication Tools	8
SHoP Architect PC Camera Obscura	10
Herzog & de Meuron Walker Art Center de Young Museum	12
Typology: Concert Hall	15
Holland Performing Arts Center Omaha, NE	16
Dee & Charles Wylie Theater Dallas, Texas	18
Diller Scofidio + Renfro Alice Tully Hall	20
Hastings College	22
Relief Map	24
Site Photographs	26
Forces Intent Diagrams	30
Program	32
Access Diagram	36
Views Lift Diagrams	38
Schematic Design	40
Surface Klein Bottle	46
Design Documentation	48
Assembly Structure Diagrams	70
The Model	72
Economy of Production Horz. Louver Diagrams	86
Bibliography	88
Acknowledgements	90

Abstract

Surface

Digital Fabrication

Making

My design thesis is an exploration of surface articulations through digitally fabricated constructs. One of the most fundamental acts of architecture has been the construction of a surface to delineate a territory. How architects conceive and make surfaces is primary to my investigations. Most certainly, it begins with the ability to invent new surface qualities through the act of making an inherently two-dimensional material into a three dimensional construct. The designer's ability to invent new surface qualities and ultimately experiences is directly related to their ability to work with materials. My personal belief is that the architect should have knowledge of and be directly engaged in the building of their designs. Digital fabrication may offer architects a methodology to directly engage in means of fabrication during the design process and ultimately in the fabrication of the final building.

Ideas | Intentions

Surface

Surface has long been the vehicle of architectural experimentation and innovation in both academic and professional arenas. One of the most fundamental acts of architecture has been the construction of a surface to delineate a territory. This surface consequently embodies the aspirations of the designer's architectural intent as it becomes more than just a physical boundary. A building is experienced through the surfaces that define its spatial relationships. Through a the surface, we develop our perception of a building. Therefore, it is my intention to further the discussion of architectural surfaces through an investigation in surface qualities and how they can be articulated.

Digital Fabrication

Digital fabrication may offer architects a methodology that would allow designers to regain control over the production of buildings. Digital fabrication allows the architects to almost instantaneously produce scale models of their designs using processes and techniques identical to those used in the industry; therefore, providing valuable feedback between designing and making. It is my intention to use digital fabrication as a means of production to determine how, when, and to what degree it influences my design process.

Digital fabrication allows exploration of digitally designed architecture in physical form similar to how it will be built. Decisions made on a two dimensional computer screen do not allow adequate exploration of spatial, material, and jointure relationships. I wish to explore how digital fabrication allows the architect to reengage with the physical act of making through a direct interaction with materials and methods of production.

Digital fabrication allows a method of fabrication to explore surface qualities in the physical realm. By utilizing digital fabrication methods through the design process architects are better equipped to make design decisions while also informing the means and methods by which the final construct will be built. The production methods can be directly adapted to the larger scale of construction using the file to factory method. This method utilizes the data from digital design to fabricate elements of the final construct.

Making

Since the Renaissance, the architect has been removed from the building site and needed to externalize information to communicate with tradesmen on site to carry out their design. Since that time, architects have gradually lost control and decision-making power over the building process as the gap between conception and construction widens. It is my intention to explore a method of designing that allows the architect to once again regain control over their design from conception to construction/fabrication.

The dialogue between designing and making should be a two-way process. The contemporary architect should not leave the making or fabrication an afterthought, but instead, it should be integrated early in the design process for an integrated approach that informs each other. The architectural design process is then approached with a mind for building throughout. Not to cheapen the early design but to enrich the final construct.

Digital Making of Buildings

Engaging Building

Architects who are known for their curvilinear forms and “blobby” architecture have been forced to engage with how their buildings are constructed because conventional contractors are reluctant to take on seemingly un-buildable projects. These architects consequently became intimately involved in the “digital making of buildings” as they sought ways to directly relate their design to contractors and fabricators. Their greater contribution is not the curvilinear forms and abstract gestures they have created but the new design and production methodologies they developed in order to optimize their designs for construction. They were forced to become intimately involved in not just the design but also the making and therefore gain control over the realization of their design. I argue that the contemporary architect should be intimately engaged in the building process in order to bring the architect closer to the construction and shrink the gap between conception and construction. |

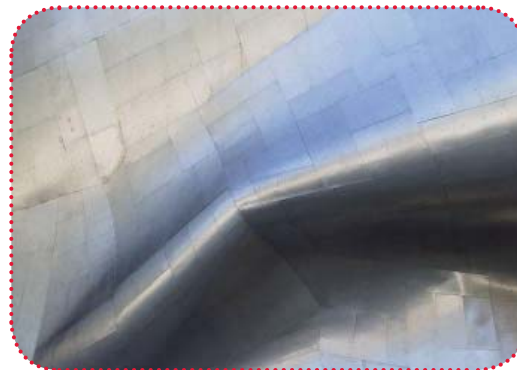
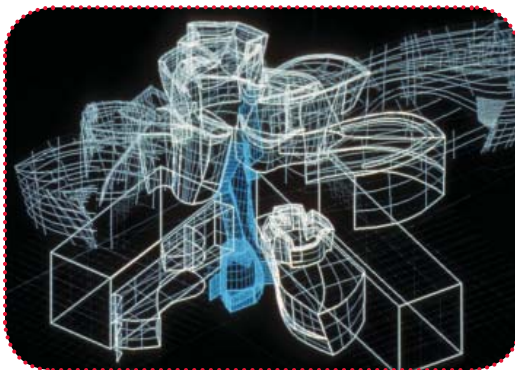
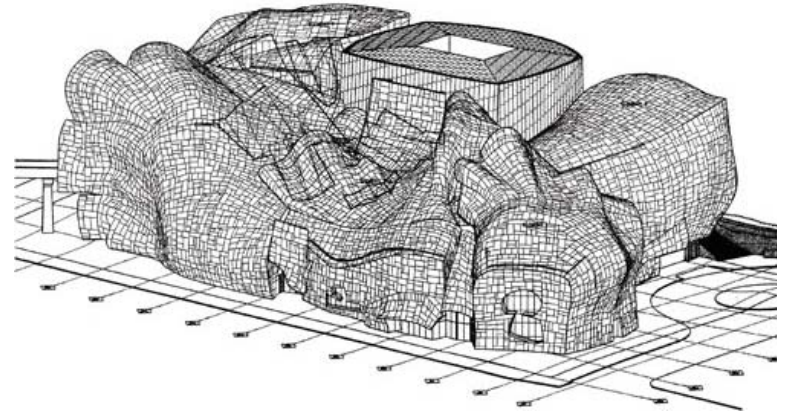

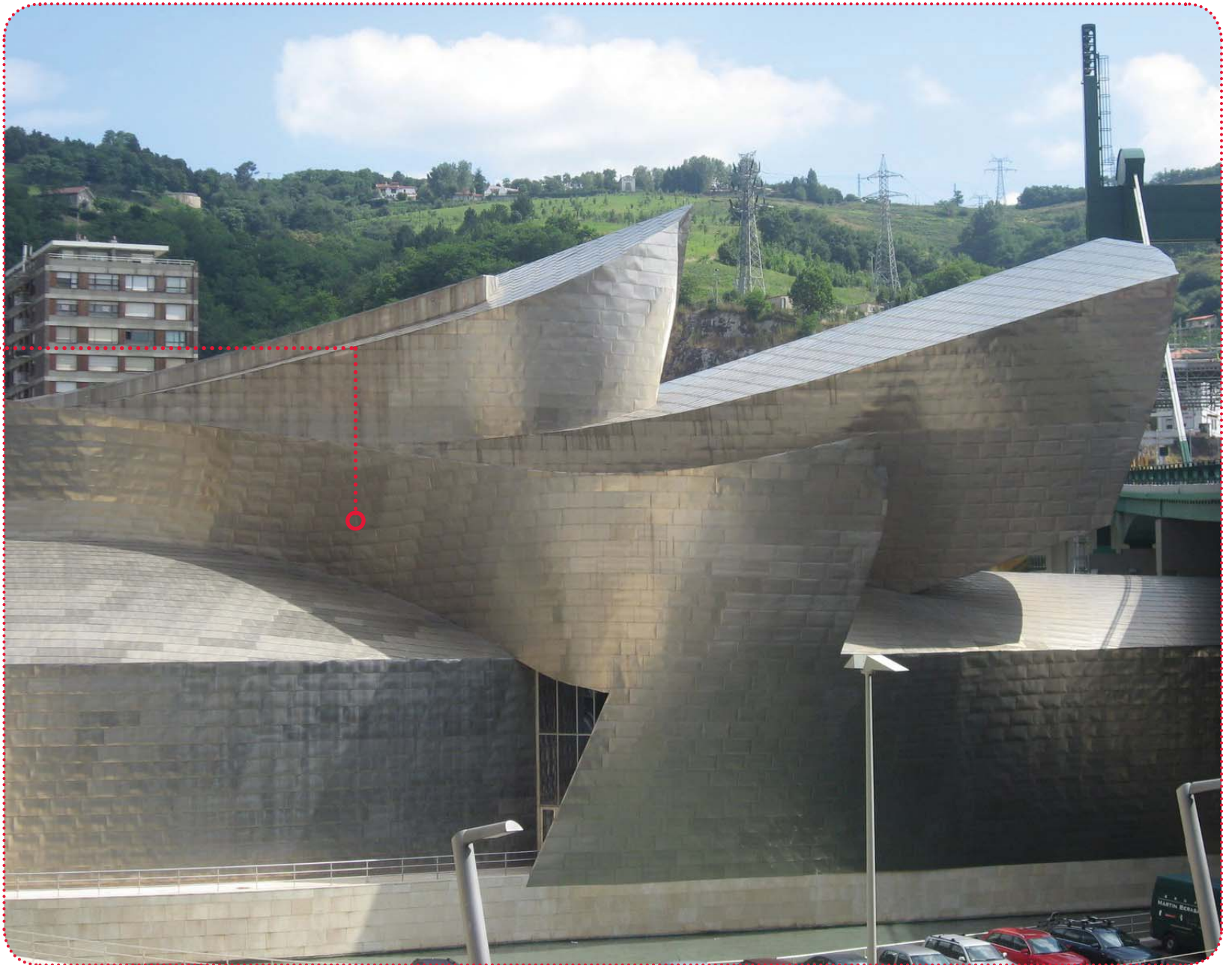

Digital Fabrication Tools

CNC Router

Laser Cutter

CNC Bender

3D Printer

In order to embrace the means of production, I will engage digital fabrication machines directly to experience the relationship between conception and production. These machines are used primarily by architects to inform their process by creating models and mock ups, but the same design information used during the process also becomes essential for the fabrication of the final construction. As a result, the architect is coming into the role as information manager and having a direct relationship to the fabricator.

My areas of exploration will be limited to a 3-axis, CNC router and laser cutter due to availability. These two digital fabrication machines should adequately allow me to explore the intricacies of surfaces and the relationship between conception and production. There may also develop a need for a 3d printer which would provide valuable feedback as it would require direct interaction with a fabrication shop and the transfer of digital files. |.....



CoOP EDITORIAL
PUGH + SCARPA

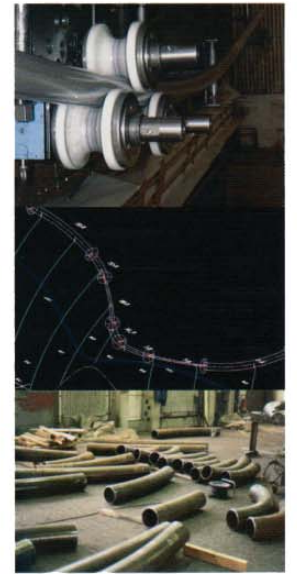

SHoP Architects PC | Camera Obscura

Greenport, NY

This project was a test case for public work in the low bidder method of delivery. This method is predicated on the ability to specify equal interchangeable components. However, this limits the architect to using off the shelf products and doesn't allow unique fabrications that are project specific. The idea is to design completely custom components and then bid them out to several fabricator-subcontractors. The components are then purchased by the general contractor as if they were parts from a catalogue. Design decisions were determined by which software and CNC processes would best suit the geometry and material selections for the building.

SHoP architects while very successful in architectural design push their expertise beyond just the design to consider the entire project. Their array of considerations include site, cultural and economic environment, client's physical needs and budget constraints, as well as construction techniques, branding, marketing, and post-occupancy issues. Their role has allowed them to streamline the design and construction process and create new efficiencies and cost savings. As SHoP Architects continue to combine roles of design, finance, and technology they are creating a new model for the architectural profession. |





Herzog & de Meuron

Walker Art Center

Several of Herzog & de Meuron's projects are surface intensive as much effort is spent on the articulation of the surface. These two projects by Herzog & de Meuron are no exception. The Walker Art Center's surface is made up of a single panel that when tiled, create the illusion of a varied surface. A single wooden frame, with identical edge profiles, was created to test a variety of folding patterns that, when abutted, would create continuous folds across multiple panels, regardless of the panel orientation.

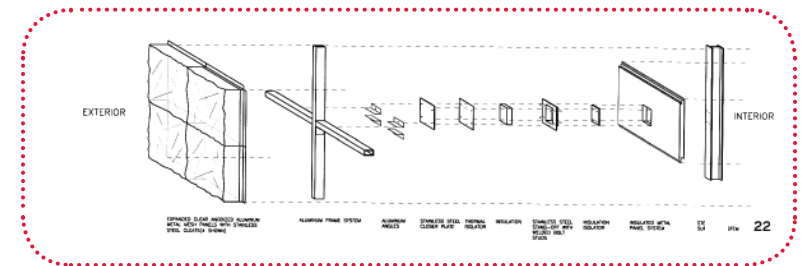

de Young Museum

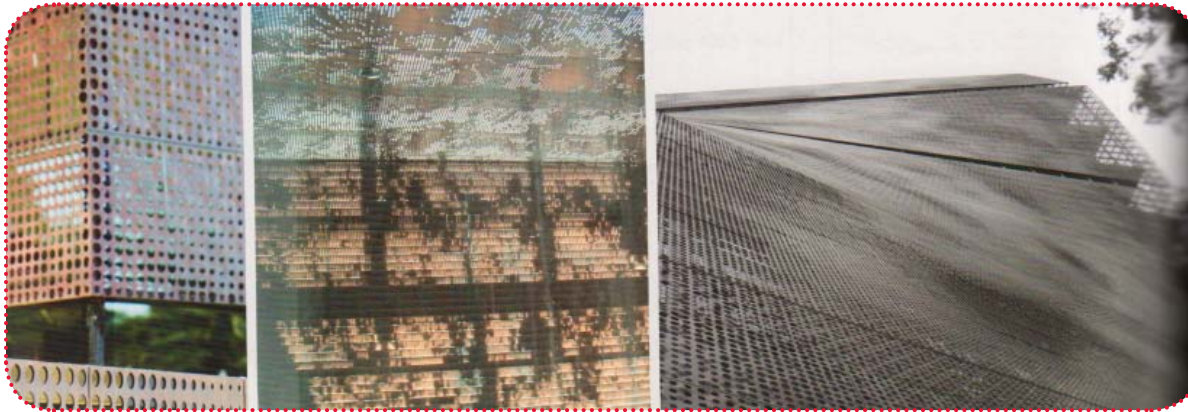

The de Young Museum's surface started with an image of a tree canopy and then became articulated through a series of perforations and embossing patterns. The desired effect was achieved by working with fabricators for more than a year to test various options to refine the pattern and density of deformations. The final result was the production of a pattern for an entire elevation of the building that was then broken down into individual panels. These projects provide valuable precedence for my design thesis both in fabrication methods and surface exploration techniques.

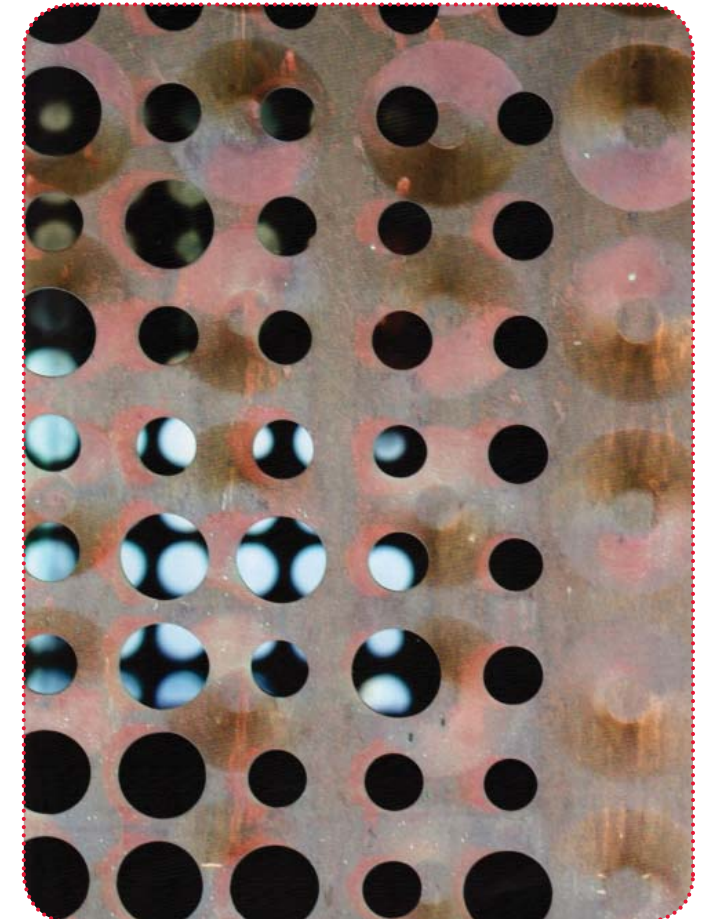
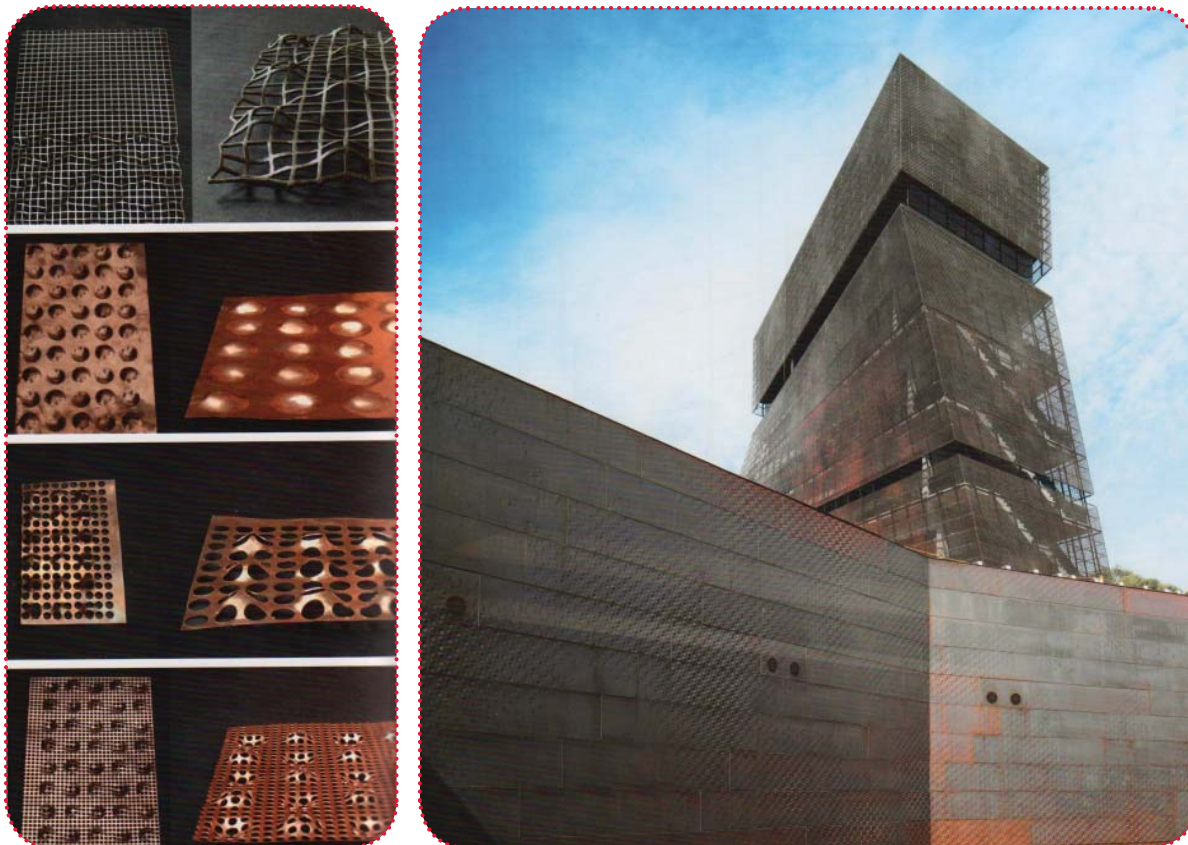

Typology: Concert Hall

Cultural Impact I chose to implement the ideas of my design thesis through the typology of a concert hall for four reasons: cultural impact; surface possibilities; location; and personal connection. The first and foremost reason I chose a concert hall was the cultural impact a civic building has on both the campus and the community of Hastings. Several relationships begin to evolve as a complexity of users both in number and diversity develop from the exploration of a concert hall on a college campus.

Surface Possibilities

Location

Need

The concert hall also has several possibilities in the area of surface exploration. As the concert hall is an icon for not only the campus but also the city of Hastings, it demands attention through cultural expectations of such buildings. This is undoubtedly expressed through the surface which articulates the building. This surface has the potential to determine form, spatial relationships, and perception of interior and exterior connections. The chosen site also allows the exploration of topological surfaces as they interact with the building. The placement of the building in close proximity to the creek and green space provides an opportunity to explore topological surface and its connectivity to the built form.

The final reason for choosing a concert hall on the Hastings College campus is their need. The need for such a facility is evident not only for Hastings College but also for the city of Hastings. Their current facility is largely inadequate and lacks the capacity to fulfill its duty as a performance hall.

Holland Performing Arts Center

Omaha, NE

The goals of this project were: to building a concert hall with exceptional acoustical abilities; to construct a facility that draws the community into the arts; to achieve a “building of distinction” that will last for generations. Architecturally, the building is successful in its ability to allow visual penetration of the façade. This has been accomplished with a glass enclosed lobby that brings the public into the building. There is also a courtyard which visually pulls one through the building. Typically, performing arts centers are very massive, opaque buildings that don't provide much visual penetration. This is generally due to the fact that several of them are organized by putting support spaces around the performance spaces.

The primary influence of this precedent is the visual penetration of the building. This is vital to draw the community into the space and make it inviting for both the public and students alike. Currently Hastings, Nebraska does not have a musical performance space of this magnitude and breaking down the barriers to engage the public in activities is essential. |





Dee & Charles Wylie Theater

Dallas, Texas

This theater provides an unprecedented reconfiguration of the traditional theater typology as support spaces are organized vertically. Conventional configurations wrap support spaces around the stage house but this project, which is under construction now in Dallas, seeks to counteract this thinking. By doing this the theater is liberated as it no longer is obscured by functional program and the public is allowed to look in on performances and theatergoers to look out on the city.

This precedent is applicable as I begin to see the need to liberate the first floor allowing a connection to the landscape and a place for student activity to take place. Stacking the support space also applies as conventional layout would not allow visual penetration of the building. The conventional layout of program would almost completely nullify the pedestrian level and overwhelm the green space adjacent to the site.



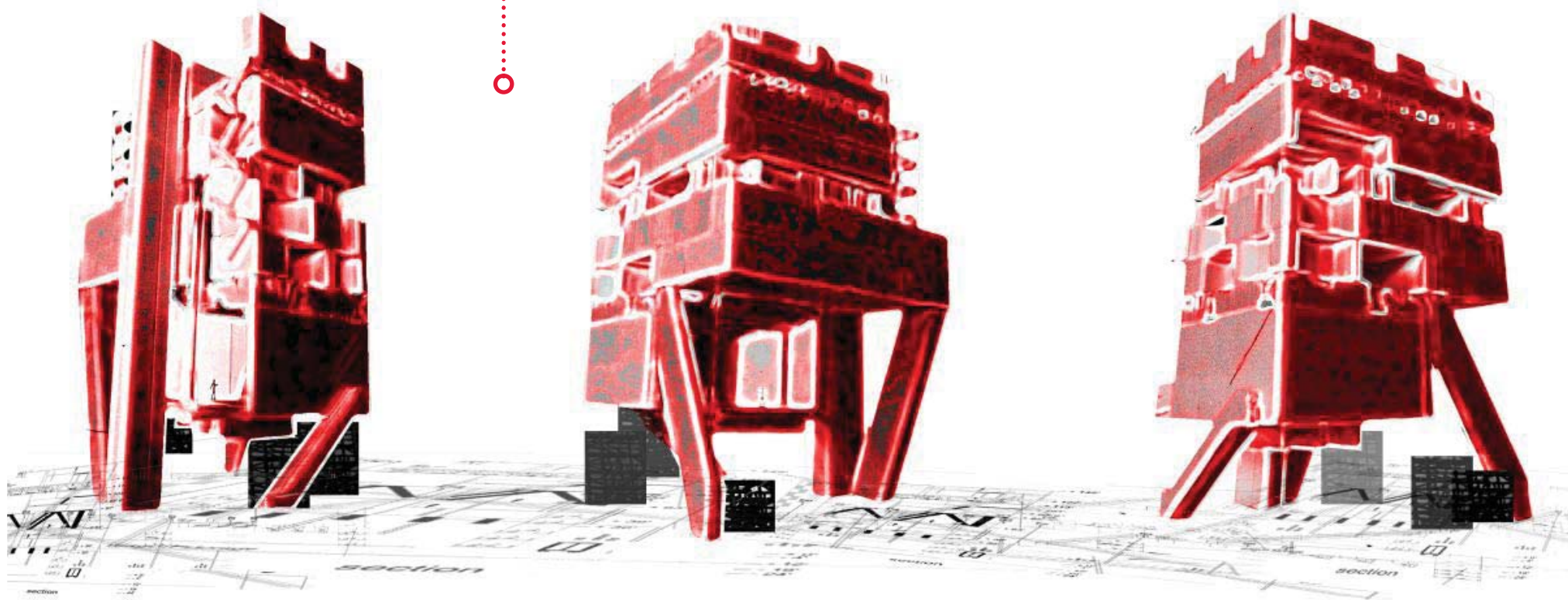

Diller Scofidio + Renfro | Alice Tully Hall

Manhattan, NY

Diller Scofidio + Renfro's ability to work with fabricators to explore surface on Alice Tully Hall provide several areas of precedence for my project. This started with their invention of a unique material, translucent wood veneer, to serve the project. They worked with 3Form for three months testing various adhesion and lamination techniques to develop a material that met acoustical requirements, and was able to be heat-formed to create complex curved panels. Once the material was developed they worked together on mock up panels to test the materials ability to perform both functionally and aesthetically. The entire project was modeled in 3-D Rhino to serve as a reference for collaboration between structural design, panel geometry, and overall dimensional control. The fabrication of the molds were pulled directly from this model. As the translucency of the glowing wood interior was primary to the success of the design each of the panels were supported from behind leaving no visible hardware to distract.

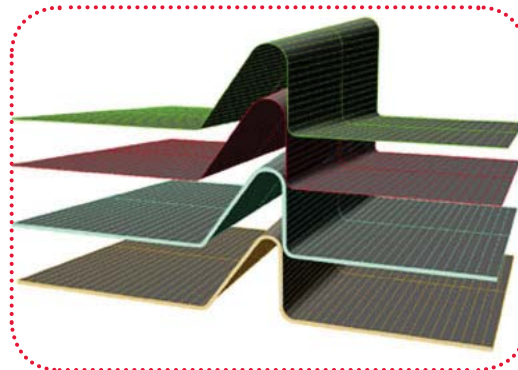



Hastings College

Hastings, NE

The project is a music performance center on the Hastings College campus. Hastings College is a private, liberal arts college located in central Nebraska. They currently have outgrown their existing music facilities housed in Fuhr Hall and are in need for expansion. The proposed project will serve as a musical performance space for the college and public as well as additional facilities for students. This project was chosen to meet the needs of an expanding Hastings College music department and for its ability to impact the Hastings community. The typology also offers several areas for exploration with digital fabrication such as surfaces to meet acoustical needs.

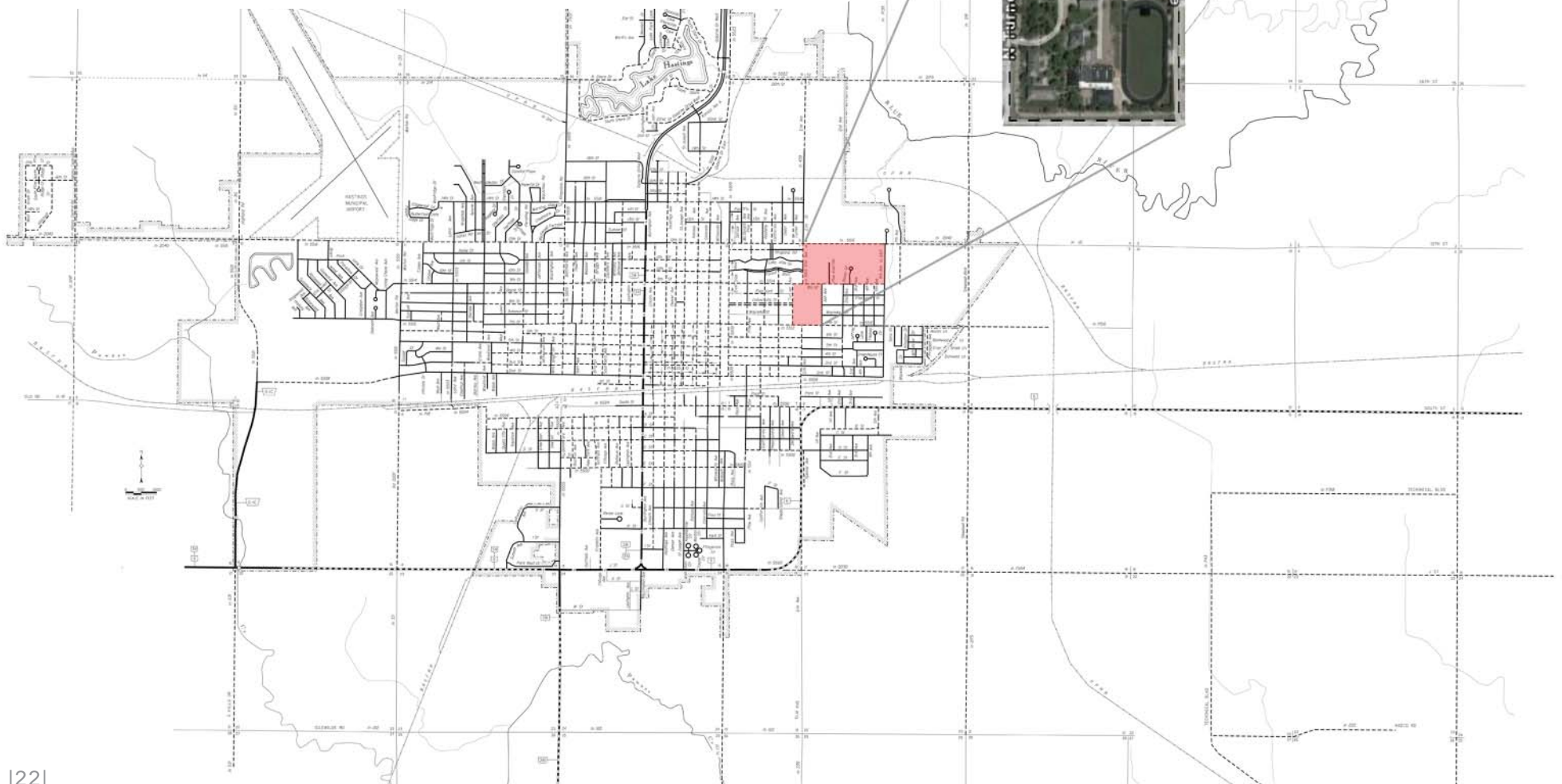

ELM AVENUE

Gray Center
Communication Arts

Buildable
Area

Farrell Arena

Stadium

Fuhr
Hall of Music

Physical Fitness

Relief Map

Hastings, NE

The site is relatively flat except for a creek that is located adjacent to the site. The positioning of the building was chosen primarily for adjacency to the existing music building (Fuhr Hall) but also as it provides connections to existing buildings and landscape. This addition becomes the face of Hastings College as it visually frames the entrance to the college. It becomes the first building seen as one approaches the college. Its positioning also defines it as the first of three primary public facilities, the other two being an adjacent sports arena and stadium. By siting the building next to one of three green spaces on campus, an opportunity to provide an architectural connection to the natural landscape is created.

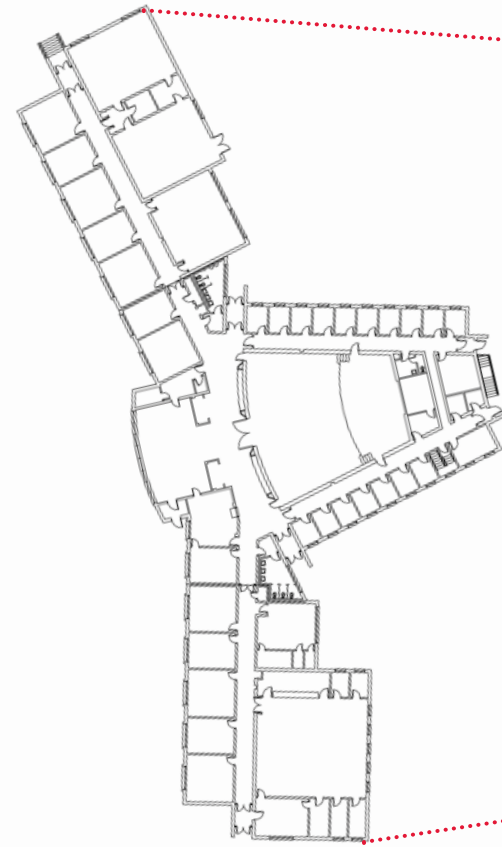

el.1913



el.1893

approach towards proposed site



.....| Site





circulation on proposed site

Fuhr Hall



Student Union



Fuhr Hall (existing music building)



Process

Forces

The contemporary architect has to manage several layers of information. Projects facing architects are becoming ever more complex along with our abilities as designers to explore multiple forces on a project. In an attempt to organize several forces that act on this project, I graphically categorized them into internal and external forces. I am making the issues conscience so that I can create a hierarchy of information and then react to them and choose which ones will have the largest impact on the project. |.....

Intent

How does fabrication influence design?
This project explores the relationship between fabrication and design. It explores the method of designing that allows the architect to regain control over their design from conception to construction/fabrication. The dialogue between designing and making should be a two-way process. The contemporary architect should not make fabrication/making an afterthought, but instead, it should be integrated early in the design process for an integrated approach that informs one another. The architectural design process is then approached with a mind for building throughout. Not to cheapen the early design but to enrich the final construct. When one approaches a project in this way, the details and precision of making can influence the abilities to explore early on in the design process and therefore provide new possibilities as opposed to being limited by means of construction. |.....

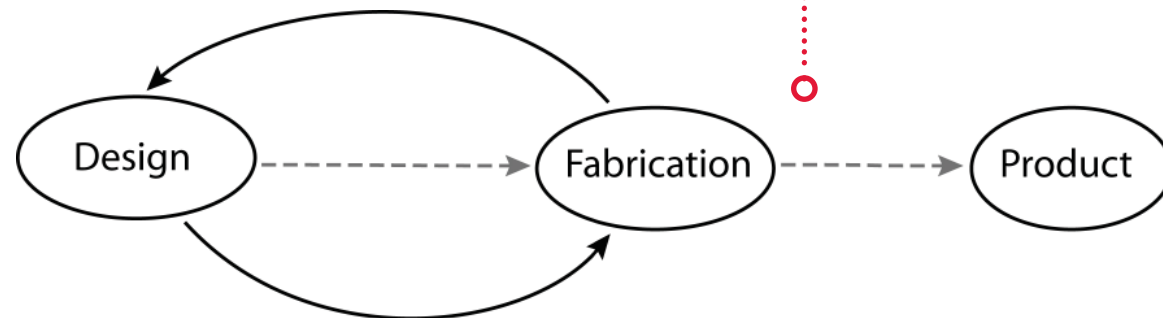

expect:
- relationships to emerge
- project information to inform strategies

Landscape
Landforms
Flora & Fauna

Existing Building

Architectural Context

Users

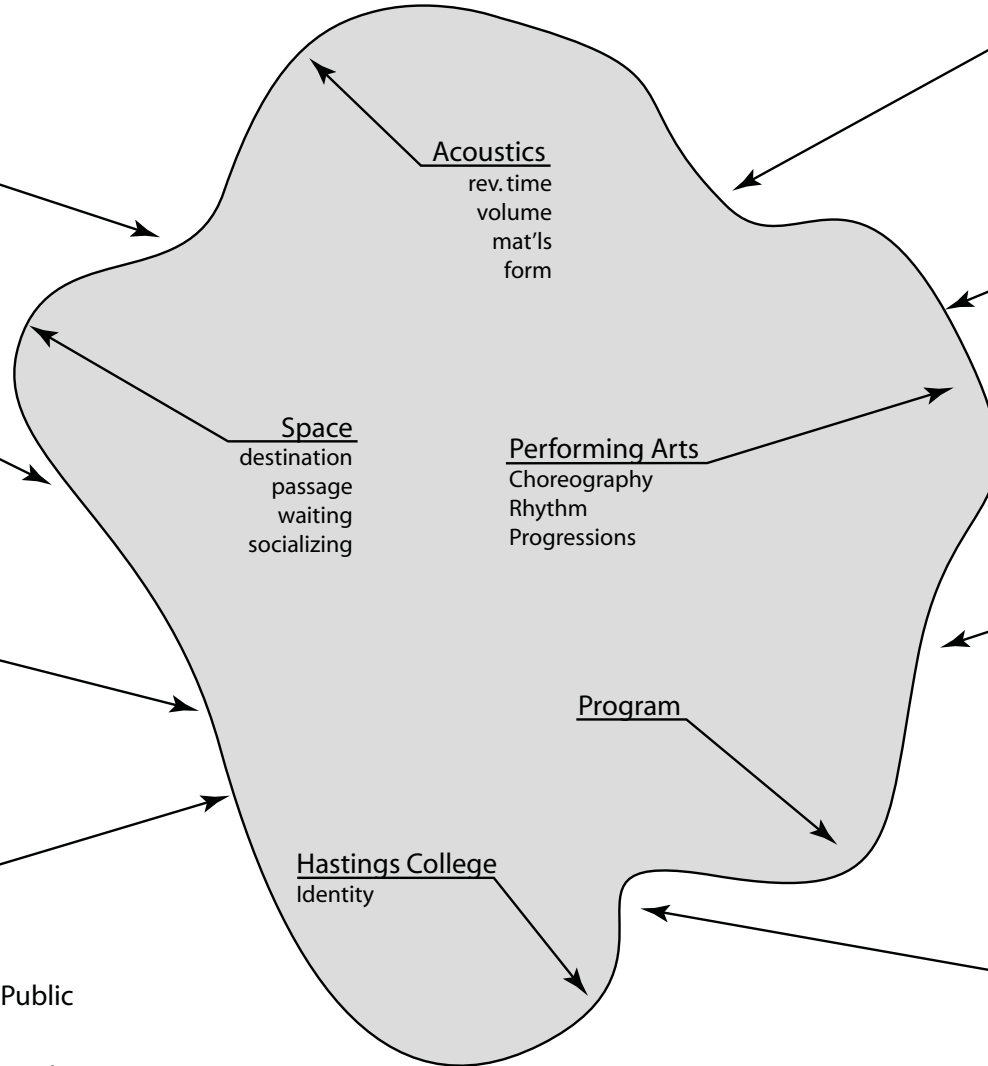
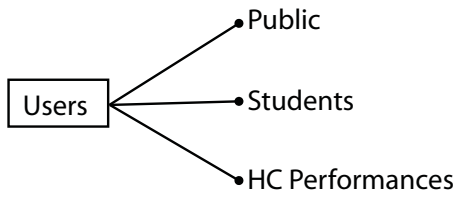

Digital Fabrication
Surface
Joinure
Materials

Climate

Orientation
sun
views
relationships

Site
parts to whole

Access/Circulation

Hastings College

Program	Concert Hall 1000 seats
	Lobby Area
	Reception Area (Multipurpose) [Integrated with Lobby?]
	Dressing Rooms 6 – Individual 2 – 30 Person 1 – Guest Artist Private
	Green Room
	Conference Room
	Offices
	Instrumental Rehearsal Hall Student Lockers Instrument Storage Individual Practice Rooms
	Restrooms – public
	Equipment Room – Control Room Lighting Sound Recording
	Loading Docks Adjacent to Back of Stage

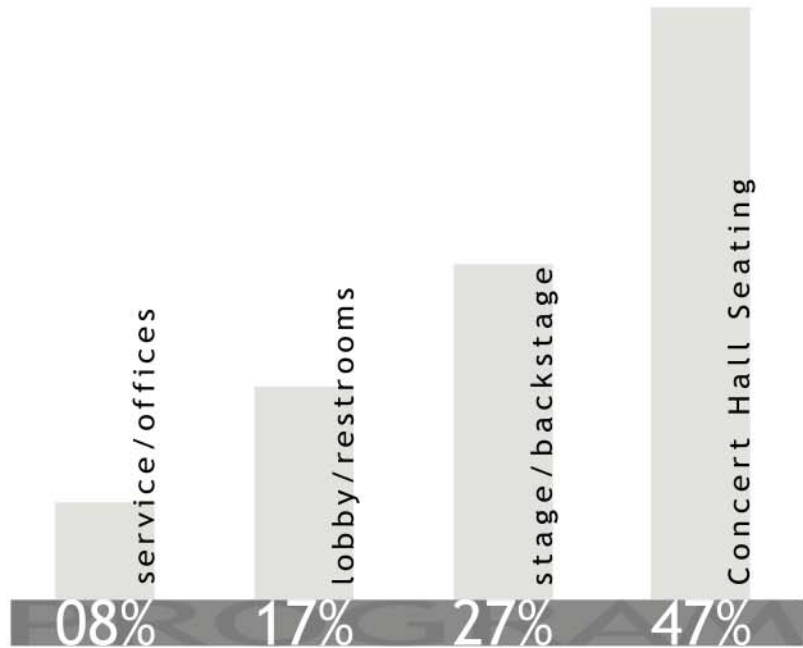
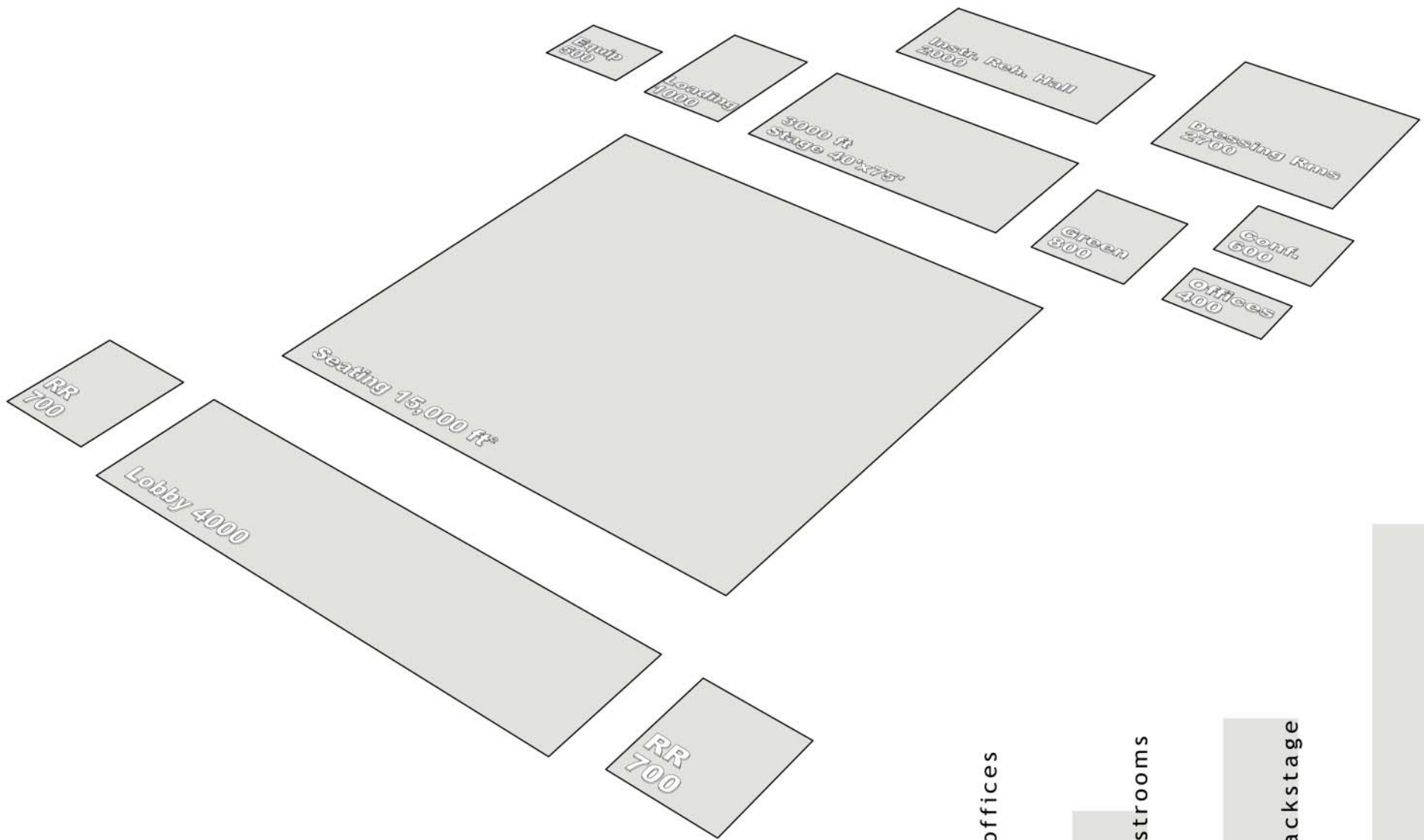

Program Arrangement



The typical layout of program by their adjacencies overwhelms the site as the horizontal arrangement creates a large footprint. This impedes circulation and overpowers the green space.



By moving the lobby and backstage above the performance area, the building footprint is drastically reduced.



The entire program could then be moved up to liberate the first floor.

LOBBY BACKSTAGE
PERFORMANCE



The circulation paths are then allowed to continue under and through the building.

LOBBY BACKSTAGE
PERFORMANCE



MECHANICAL

The space below ground could then be allocated for mechanical use.

BACKSTAGE
PERFORMANCE



LOBBY
MECHANICAL

The lobby can then be moved to the first level for the entrance procession but must be kept open to allow space to flow through.

BACKSTAGE FLY
PERFORMANCE



MECHANICAL

The lobby responds the existing topography and opens up towards the green space. It becomes a node of activity as it accommodates pedestrian circulation through and around the building.

Process

Access

The site is located on an intersection of circulation paths coming from all parts of campus. A key issue is to establish a link between the several users (public, students, and performers) both during a performance and also during daily activity. The building must accommodate performances by students and public but also provide for the daily activity of Hastings College without overwhelming the site. |

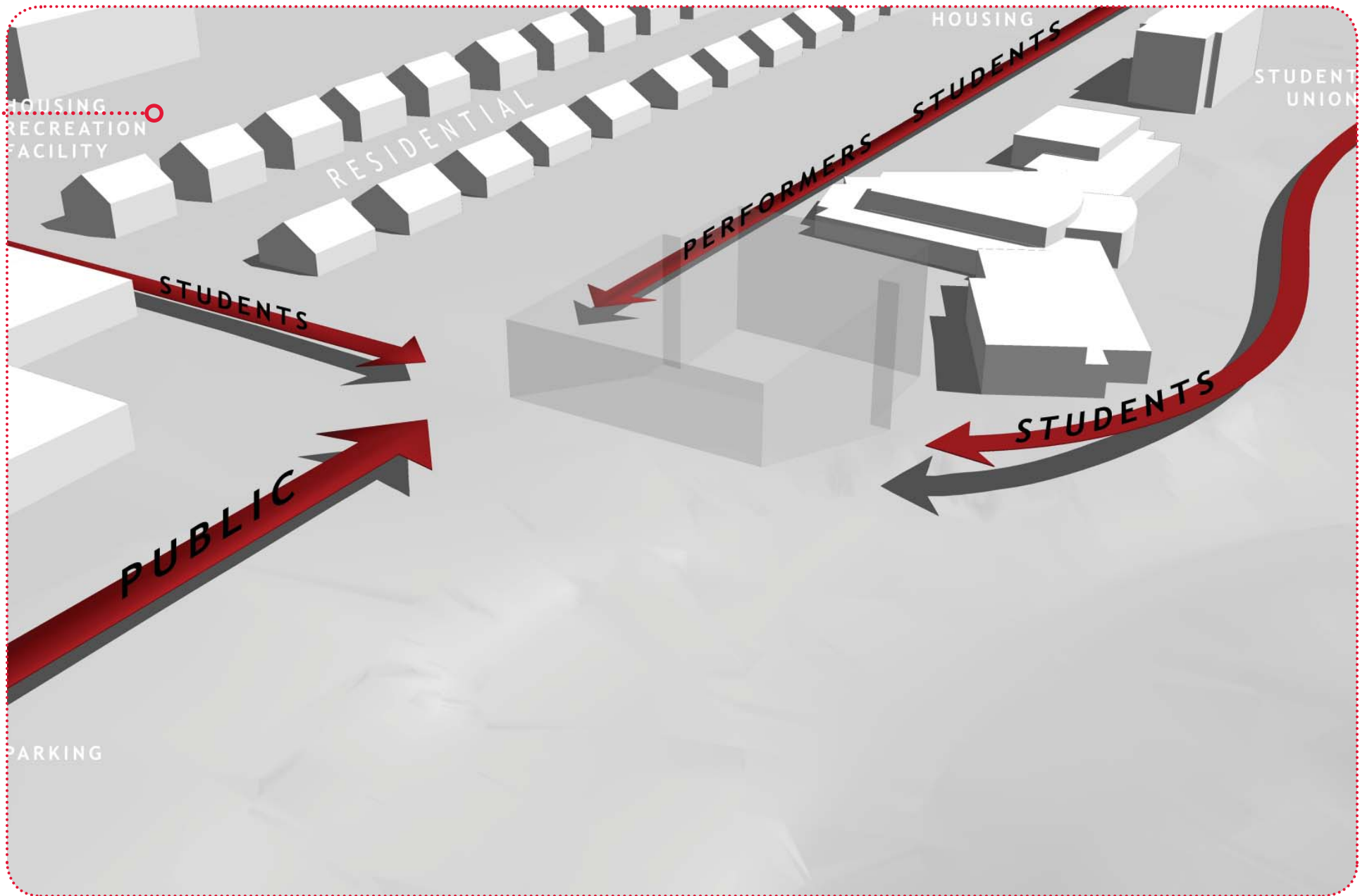

Process

Views

The lobby opens up to both the green space and the public access. The reception hall opens to the green space while the rehearsal hall opens to the public access. |.....

Lift

One end of the building is lifted up to open the lobby out onto the green space and let existing circulation paths pass in and through the building. This establishes a node of activity along the path at a place where several paths intersect. It frees the first floor to be a place of activity while allowing the entrance to musical performances to be lifted above. |.....

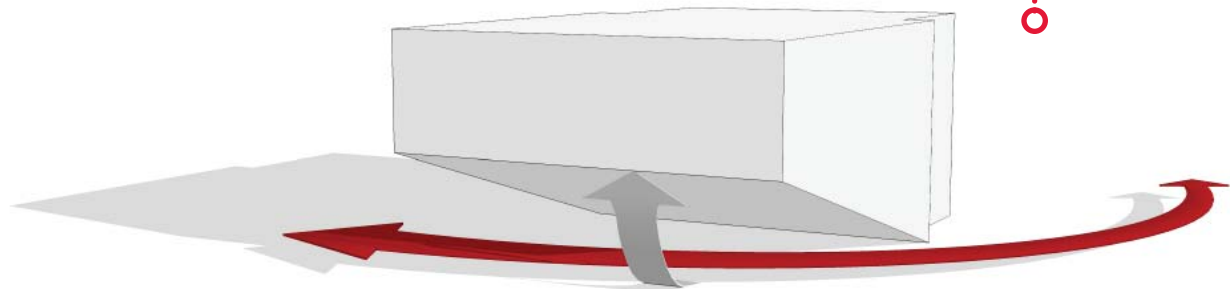

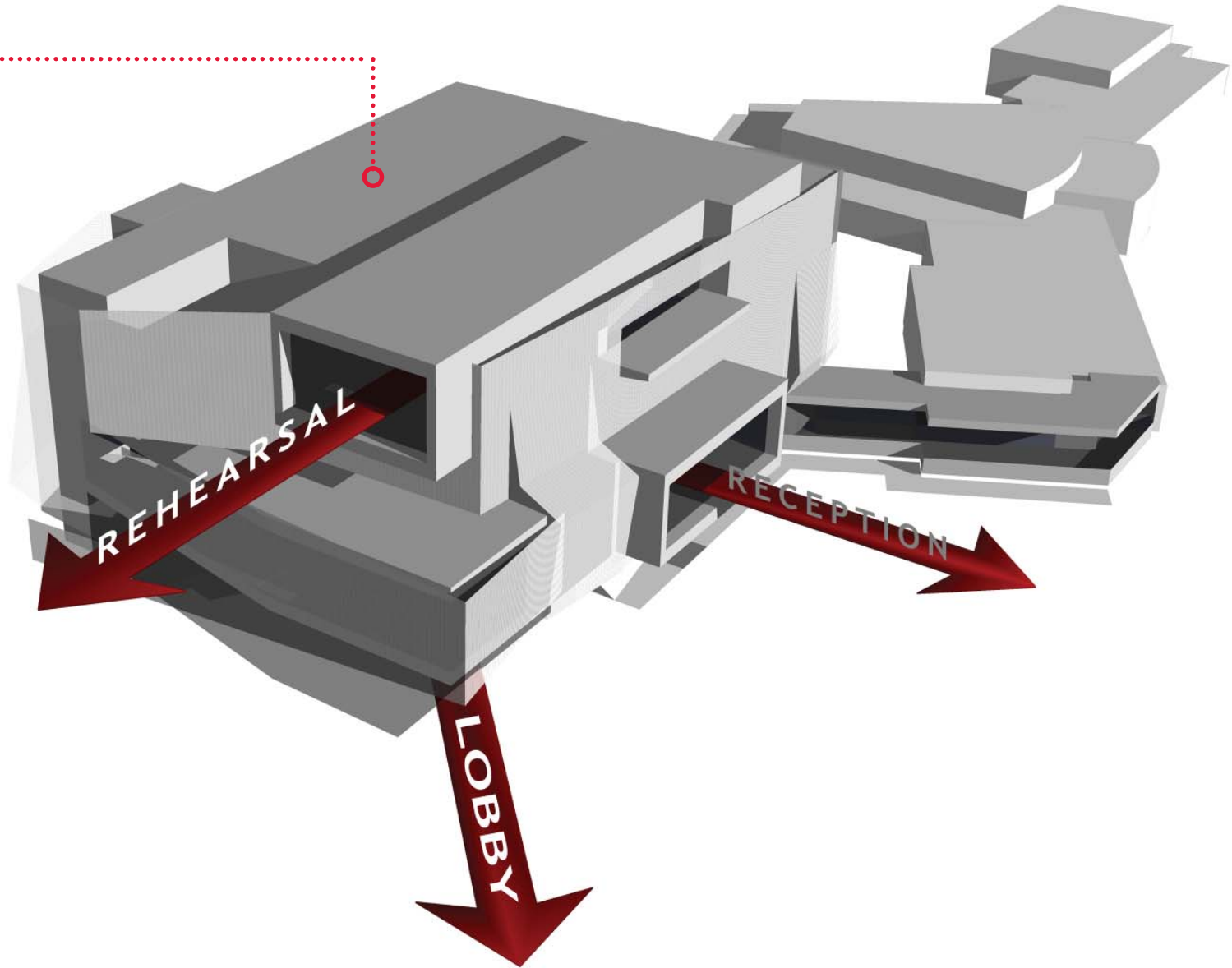

Schematic Design

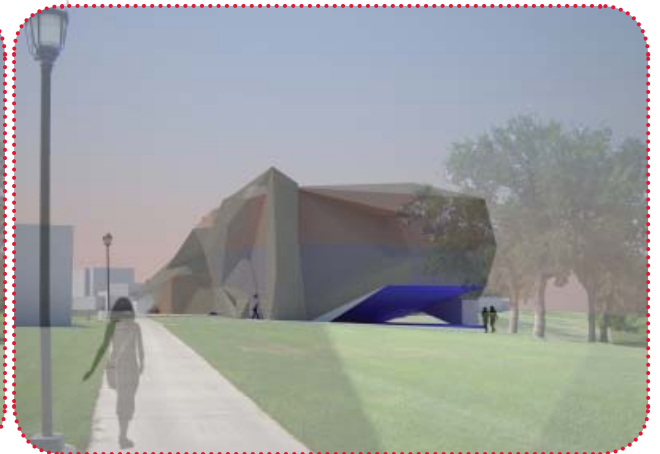
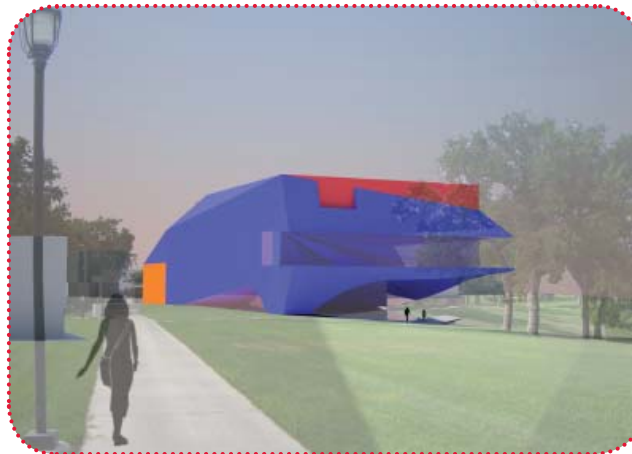
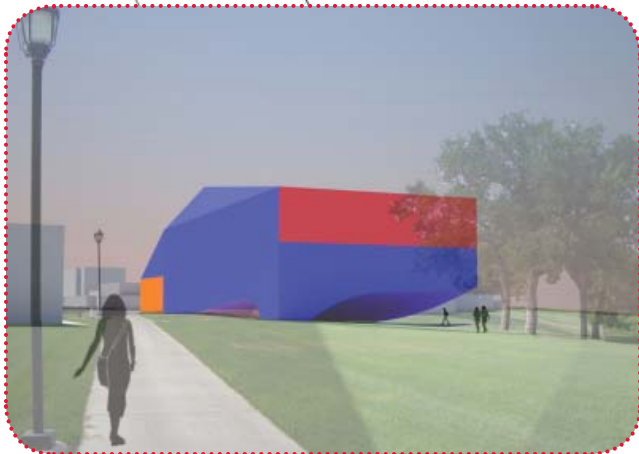
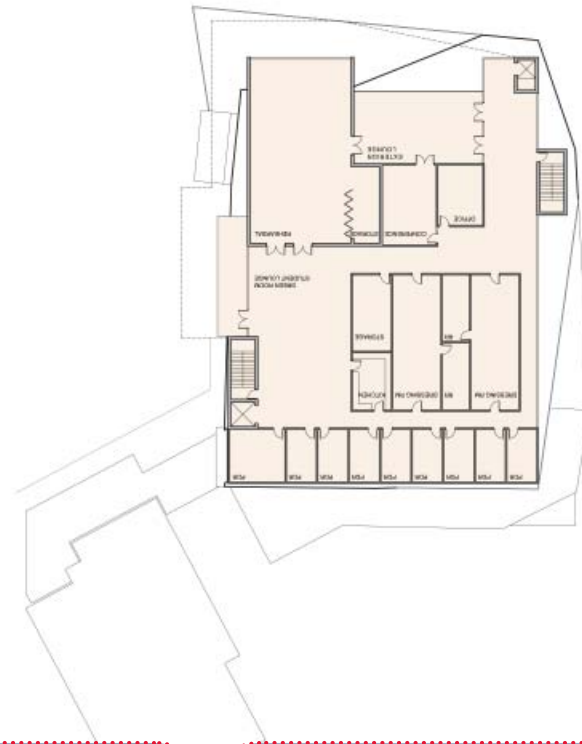
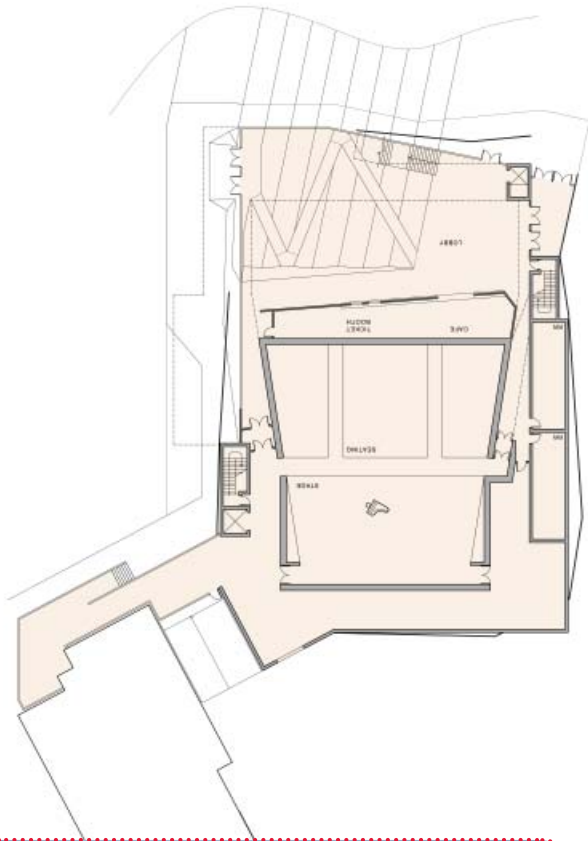

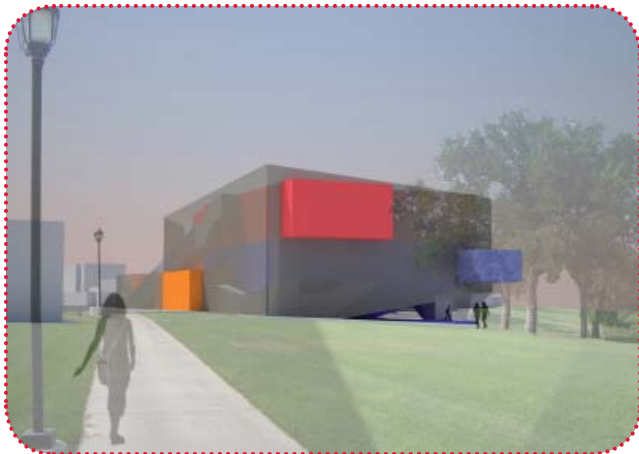
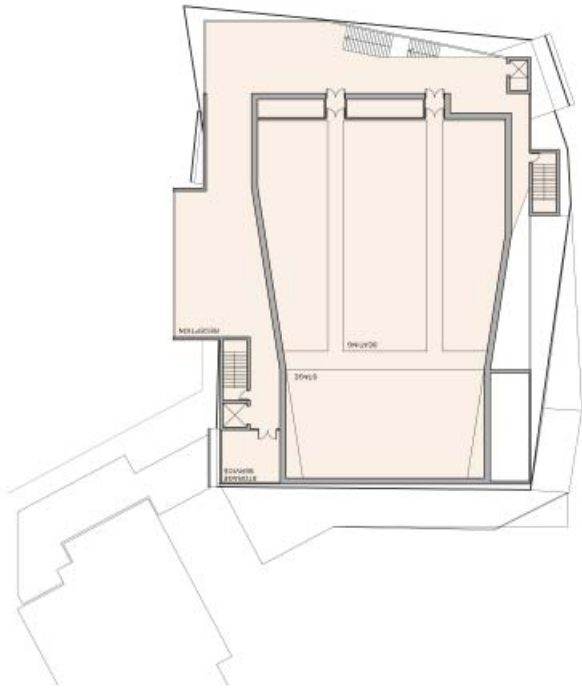

Process Models

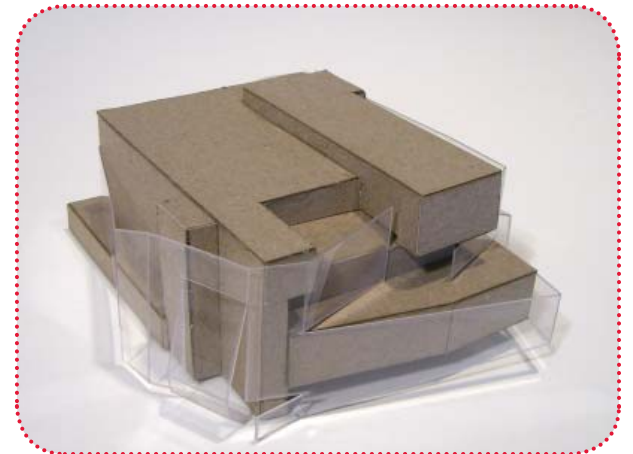
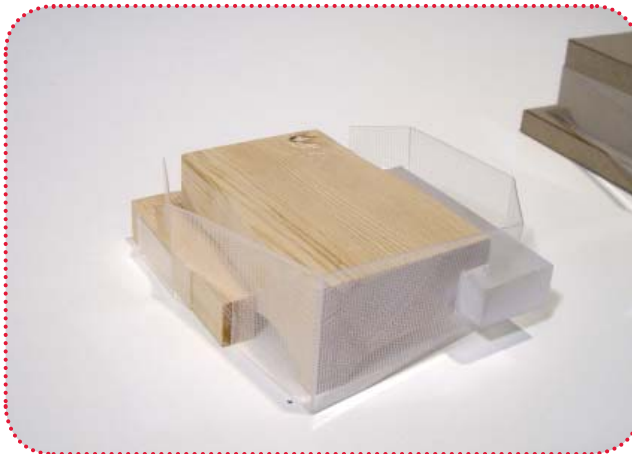
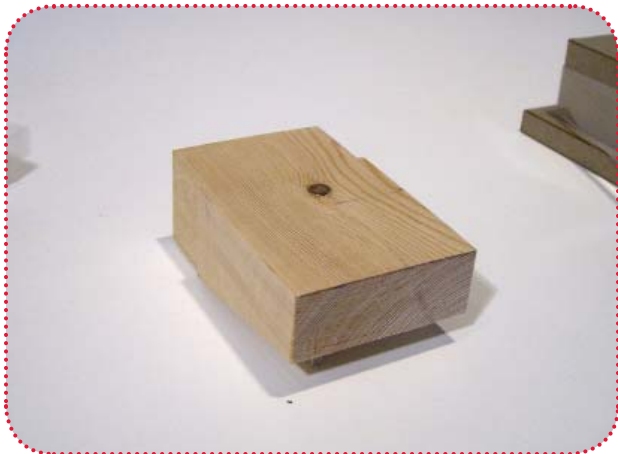

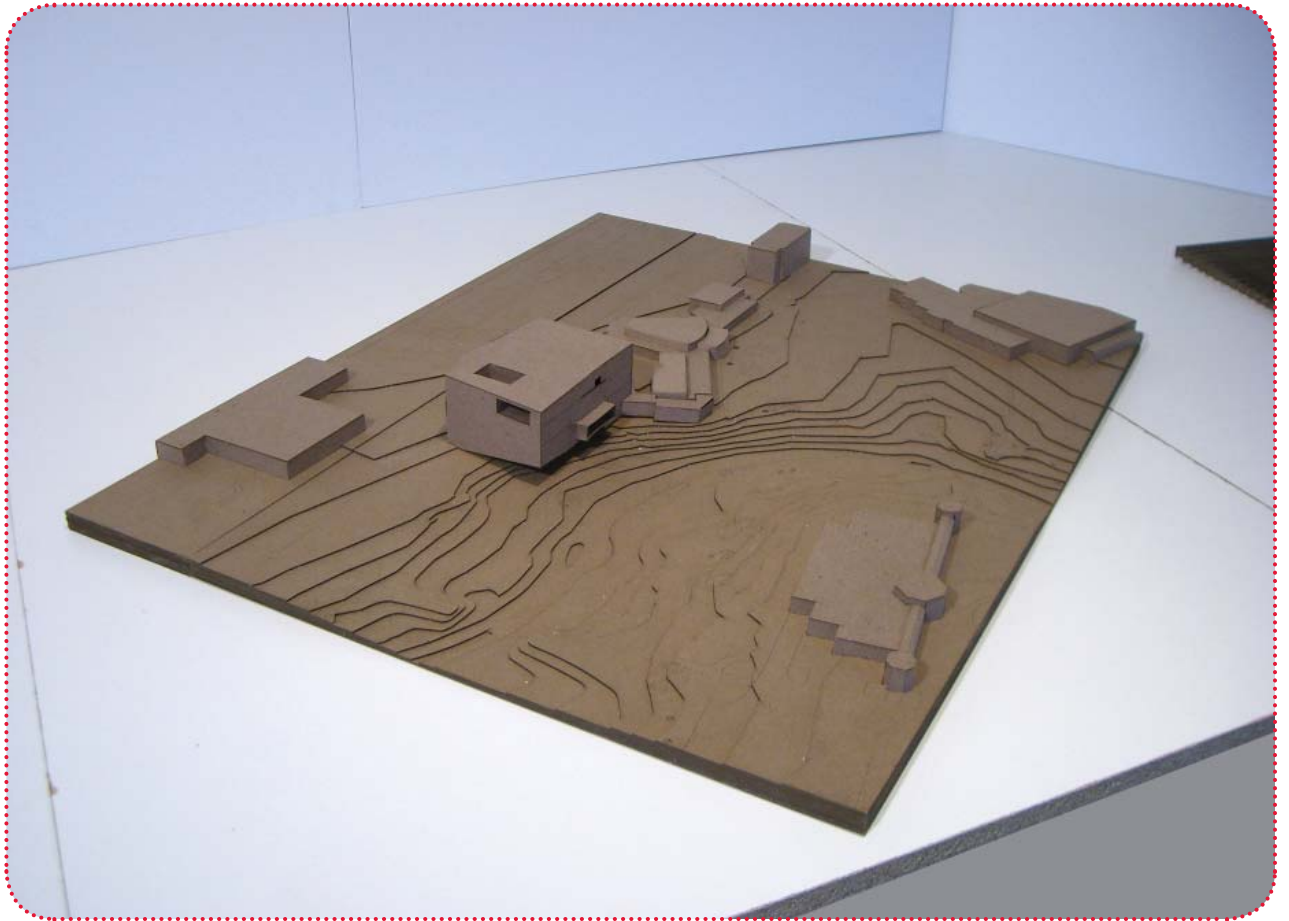
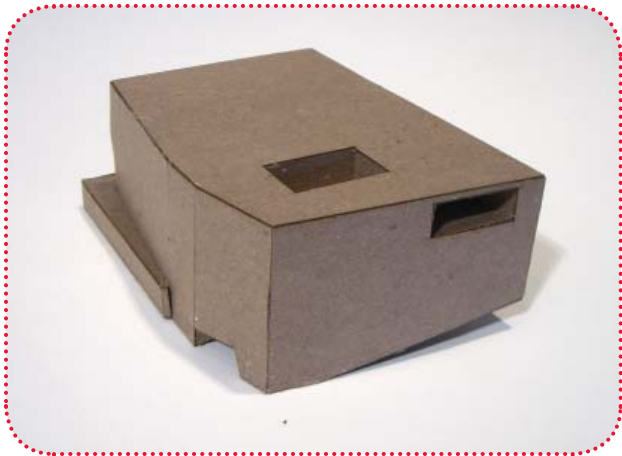

Schematic Design

Surfaces

Use surfaces to define the architectural solution spatially, acoustically, functionally, and aesthetically while also providing valuable feedback on the relationship between conception and production. These will be explored further in the design development phase of the project with digital fabrication machines.

Exterior Surface

This surface will allow visual penetration into the building through varying transparencies as it is developed further. It also provides area for circulation outside of the main shell of the hall. The surface gains its form by responding to the organic nature of the creek and green space adjacent to the site.

Acoustical Surface

This surface responds to the acoustic needs of the hall but also becomes aesthetically beautiful as a marriage of the form and function is expressed. To enhance the acoustic qualities of reverberation and projected sound the surface will be irregular and non-repetitious with no parallel surfaces.

Concert Hall Shell

This shell provides the acoustical separation for the hall.

Topological Surface

This surface will provide the building's connection to the site starting on the interior and flowing out to the exterior. It will negotiate between the building and the ground to provide an extension of the building out into the landscape and also bring the landscape into the building.

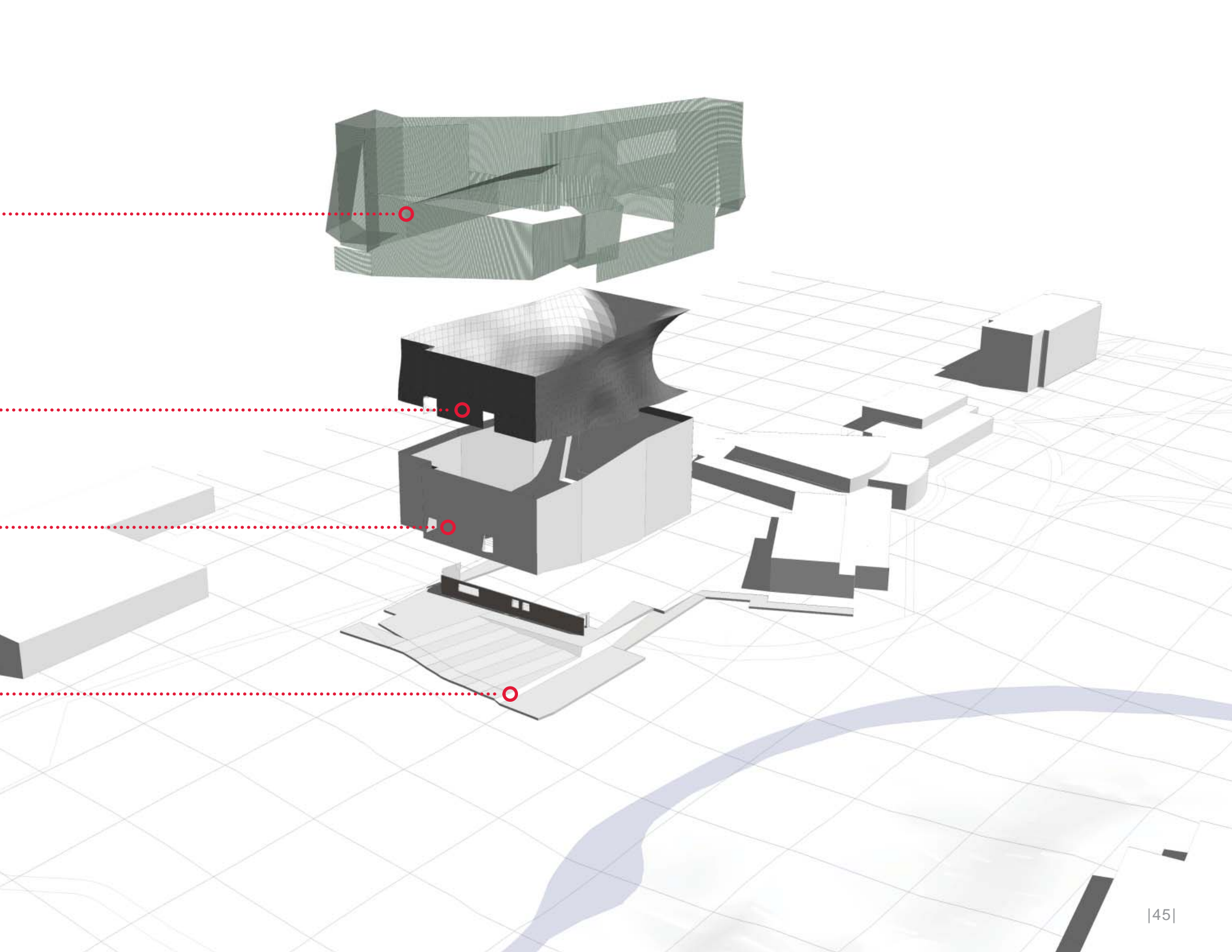

Surface

Klein Bottle

A **Klein bottle** is a topological space, named for the German mathematician Felix Klein, obtained by identifying two ends of a cylindrical surface in the direction opposite that is necessary to obtain a torus. The surface is not constructible in three-dimensional Euclidean space but has interesting properties, such as being one-sided, like the **Moebius strip**: being closed, yet having no “inside” like a torus or sphere.

Upon evaluation of my progress at the end of the first semester, I realized I had adequately explored several separate surfaces that defined my project. The issue that emerges was that each of the surfaces do not relate to one another. In typical concert hall arrangement, I had created an exterior surface around a separate interior surface of the concert hall. What will be the relationship between the interior and the exterior surface? In an attempt to answer this question, I began to think of the surfaces volumetrically like that of a Klein bottle. This relationship became the turning point in how I thought about the surface that defines the project. No longer were they several distinct surfaces but now they become one surface that defines the space. As the surface moves around the interior and exterior, it also creates a hierarchy of program as it delineates both the concert hall and rehearsal hall.

Surface is understood not as a threshold but as a condition that extends through the building. Whereas an envelope relates to the threshold that reinforces the separation of interior and exterior. Surface directly engages both and mediates the threshold between them.

The function of the building as a concert hall is at odds with the transparency needed for students. Therefore another layer that responds to building image, transparency, and gathering spaces in and around the building interior accommodates the needs of the concert hall. Or are they one and the same?



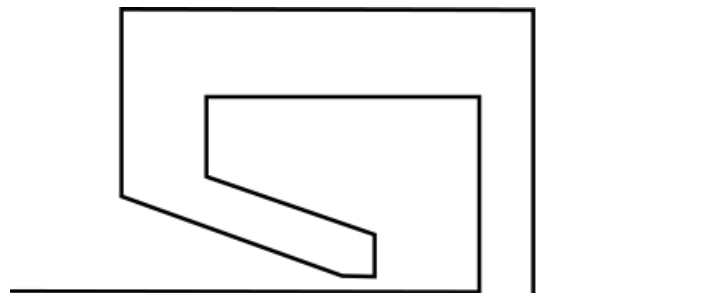
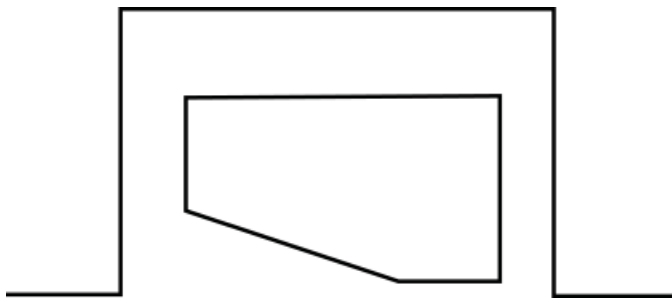

Section Perspective

Surface

The surface defines both exterior and interior spaces. Primarily it defines the concert hall and the rehearsal space. The surface varies in density and thickness to serve acoustical, solar, visual, and aesthetic needs. By allowing some flexibility in the system governing the surface, it can adapt to the given functions and aesthetics of its space. |

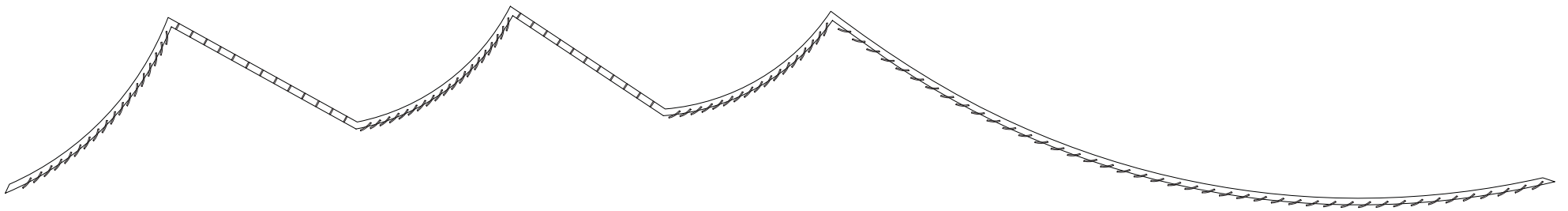

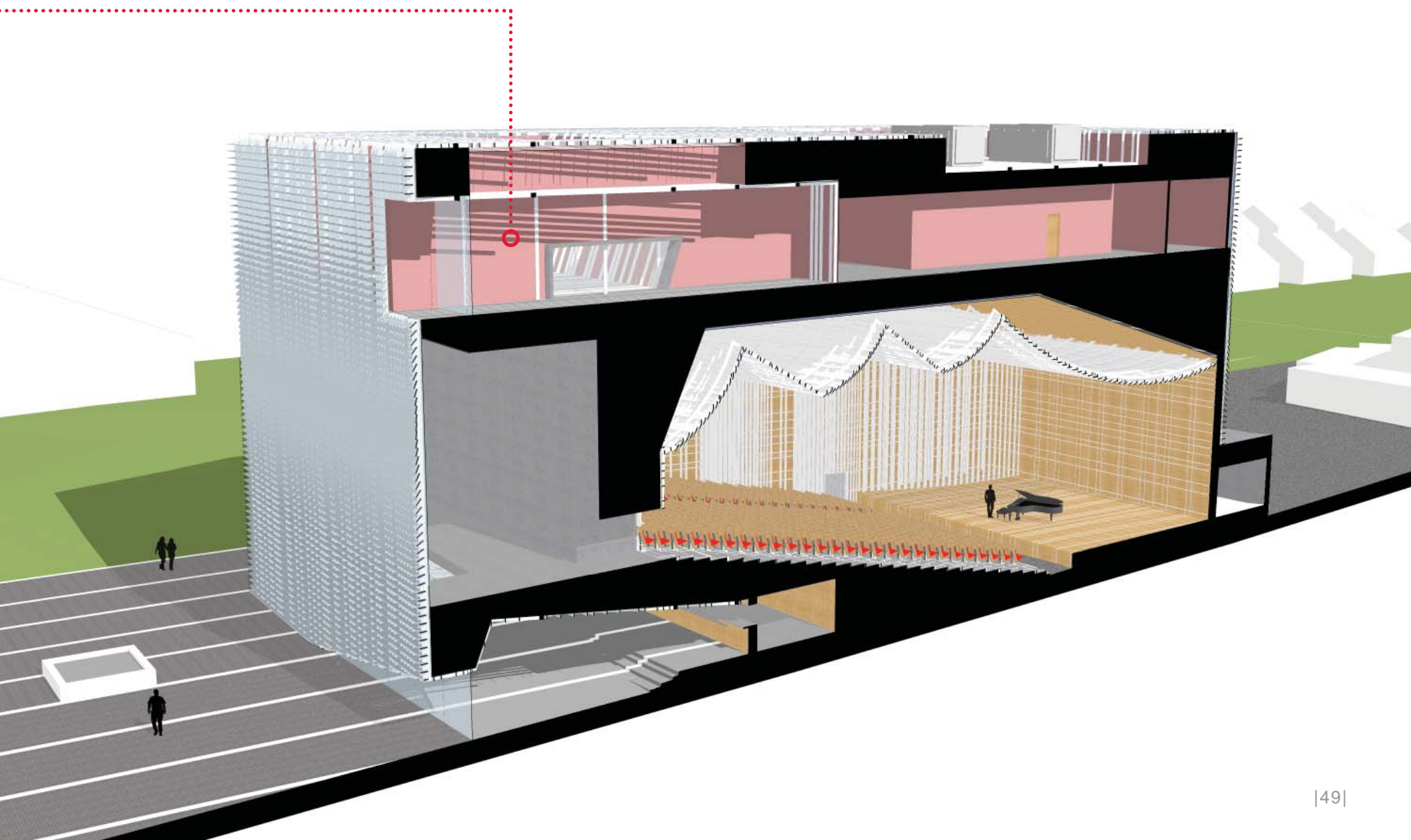

Concert Hall

Surface

The surface on the interior of the concert hall performs acoustically as well as aesthetically. The density is shifted to accommodate both needs. The more dense areas of the surface provide surfaces to reflect the sound as well as enclosing lighting fixtures that spill light into the space. The surface is articulated with reveals on the floor and stage to reveal the pattern that is carried from the exterior to the interior. The surface gaps are then filled in with wood paneling to provide a warm atmosphere. |.....

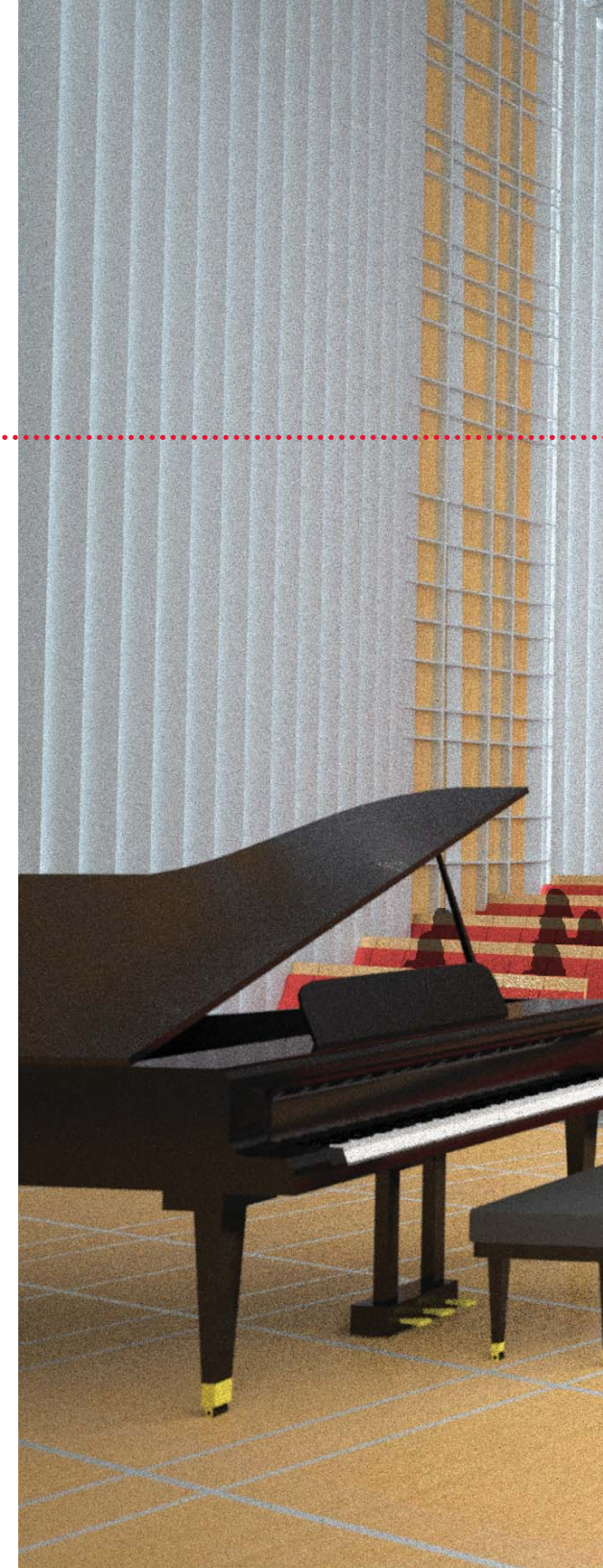

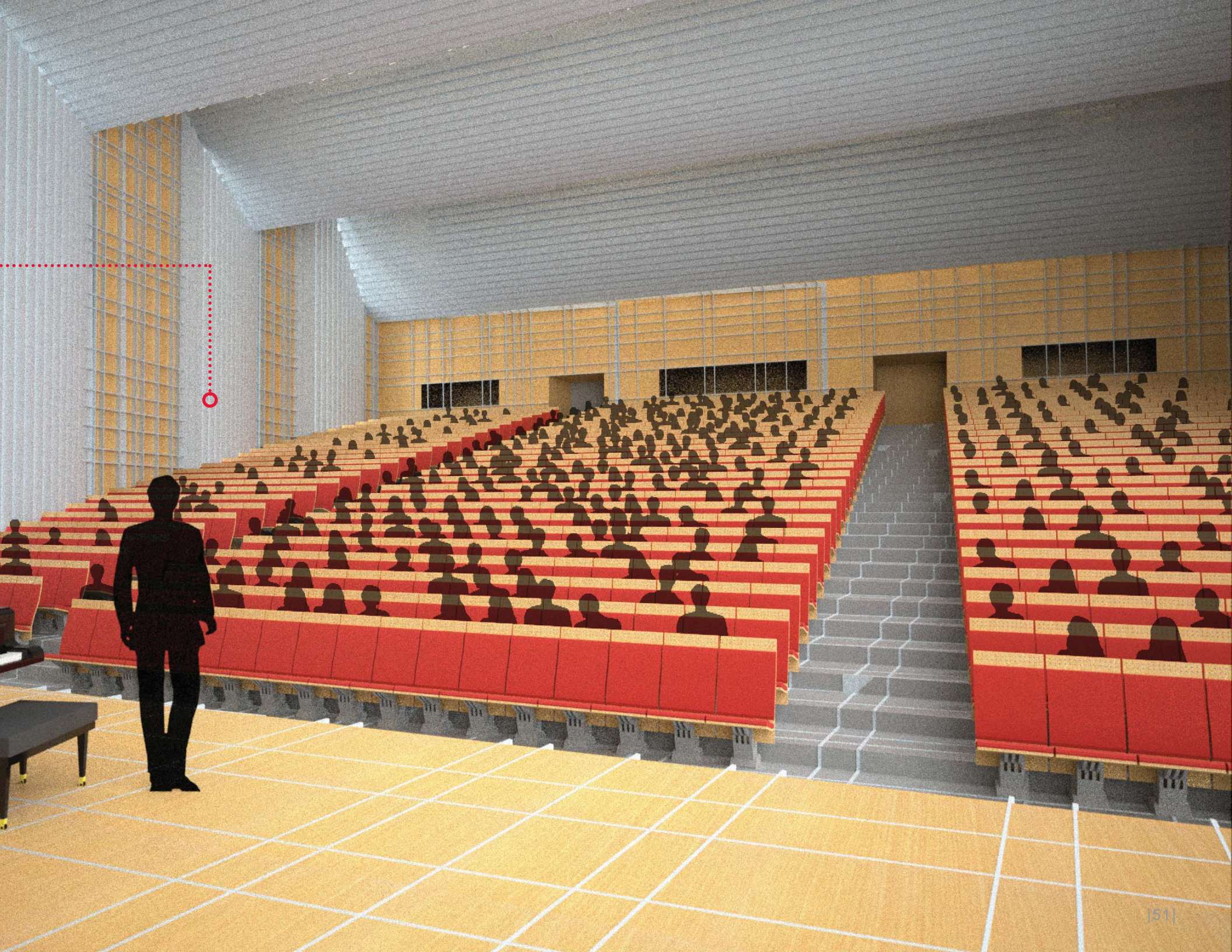

Rehearsal Hall

Surface

The surface from the exterior also pulls in to define the space of the rehearsal hall. Again, it varies in density and thickness to accommodate the space. The dual layers that form the ceiling of the rehearsal hall and the roof of the building filter light down into the space while the surface is minimized on the floor as a reveal. The two opposing walls are articulated with a surface that spreads out the louvers to accommodate openings for practice rooms on one side and connection to an exterior terrace on the other. |

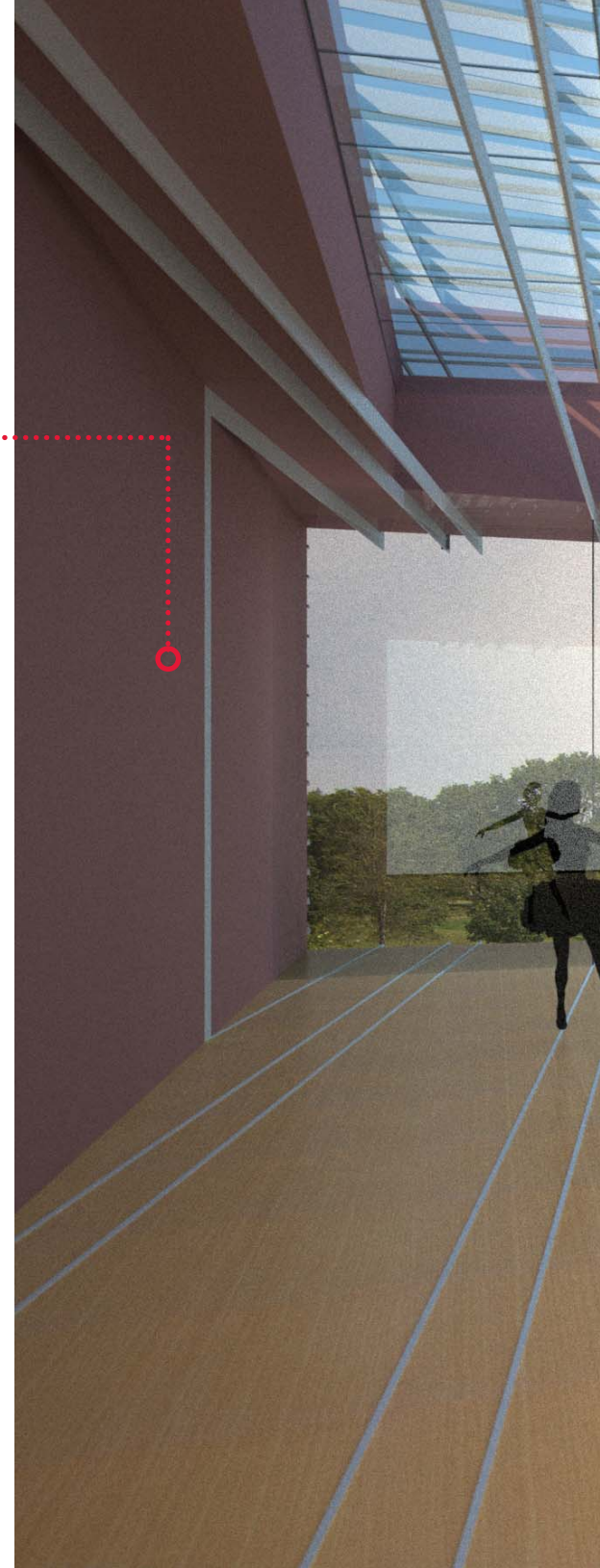



Exploded Axon

-
- Vertical Louvers** The vertical louvers encompass the entire building on both the interior and exterior. They provide the primary structure and definition of the surface throughout the project. |.....
-
- Horizontal Louvers** These louvers provide the exterior definition of the surface. They rotate about their axis as they move vertically up the building to provide views from the interior and also block solar heat gain from the exterior during summer months. They are also oriented to allow visual penetration from the exterior to see up into the building. |.....
-
- Concert Hall louvers** These louvers define the interior of the concert hall as a continuation of the vertical louvers on the exterior. Their density is then manipulated to adapt the acoustical and aesthetic needs of the space. |.....
-
- Volumetric Base** This layer of the building provides the enclosure for more private spaces as well as the structural support. It is also composed of the building's circulation cores. |.....
-
- Topological Surface** The floor of the lobby is a continuation of the exterior topography as it connects directly to the adjacent plaza. It also slopes down with the topography of the creek to further emphasize the opening of one corner of lobby which always the flow of space under the building. It directly negotiates between the building and the ground to provide an extension of the building out into the landscape and also bring the landscape into the building. |.....
-

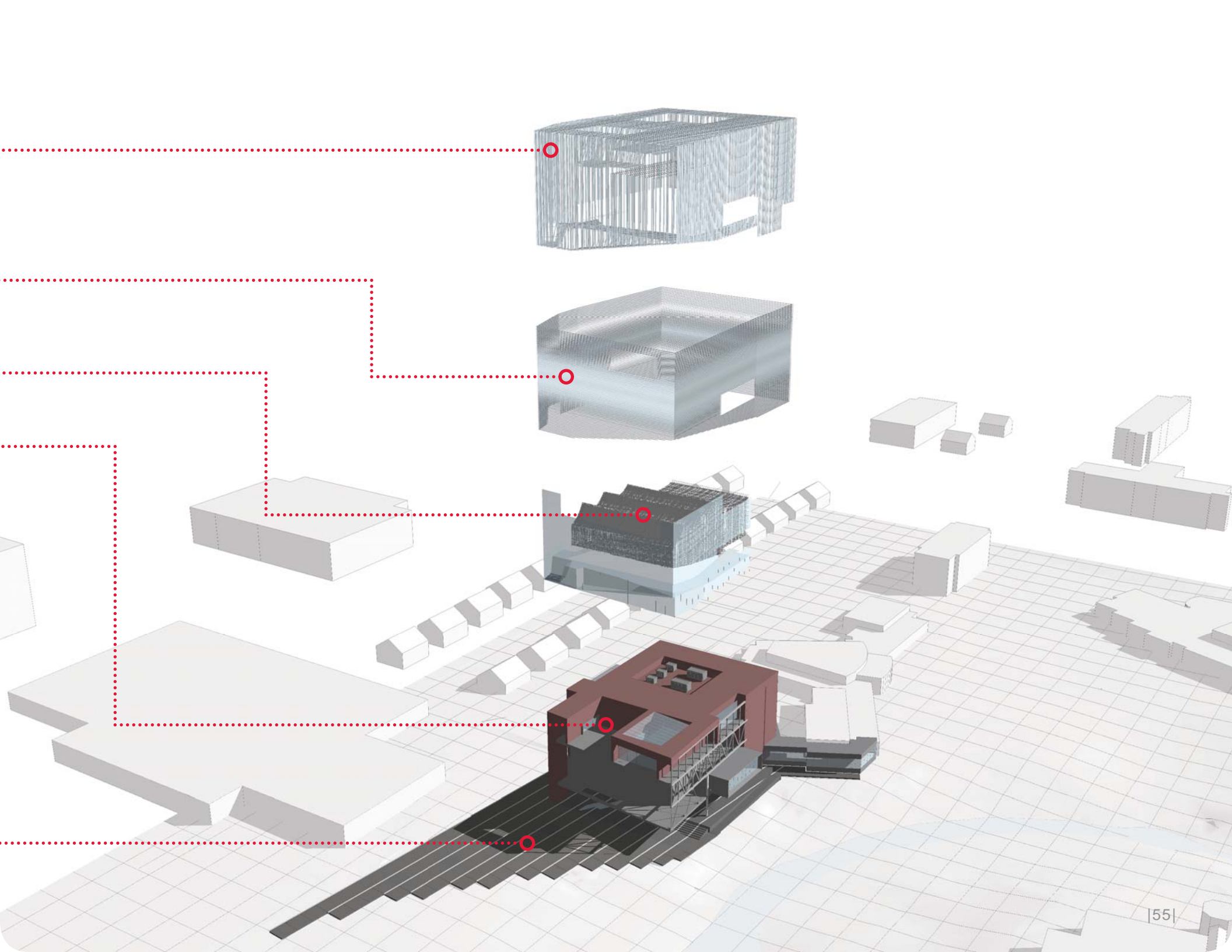

Lobby

Topography

The corner of the building has been lifted up to allow space to flow under the building and out onto the landscape to blur the line between interior and exterior. The topological surface flows inside the lobby and up the stairs to further emphasize this connection. The floor level of the entrance stays consistent to provide adequate circulation in and around the concert hall, but the corner of the lobby slopes down becoming more of a landscape for students to lounge on. |

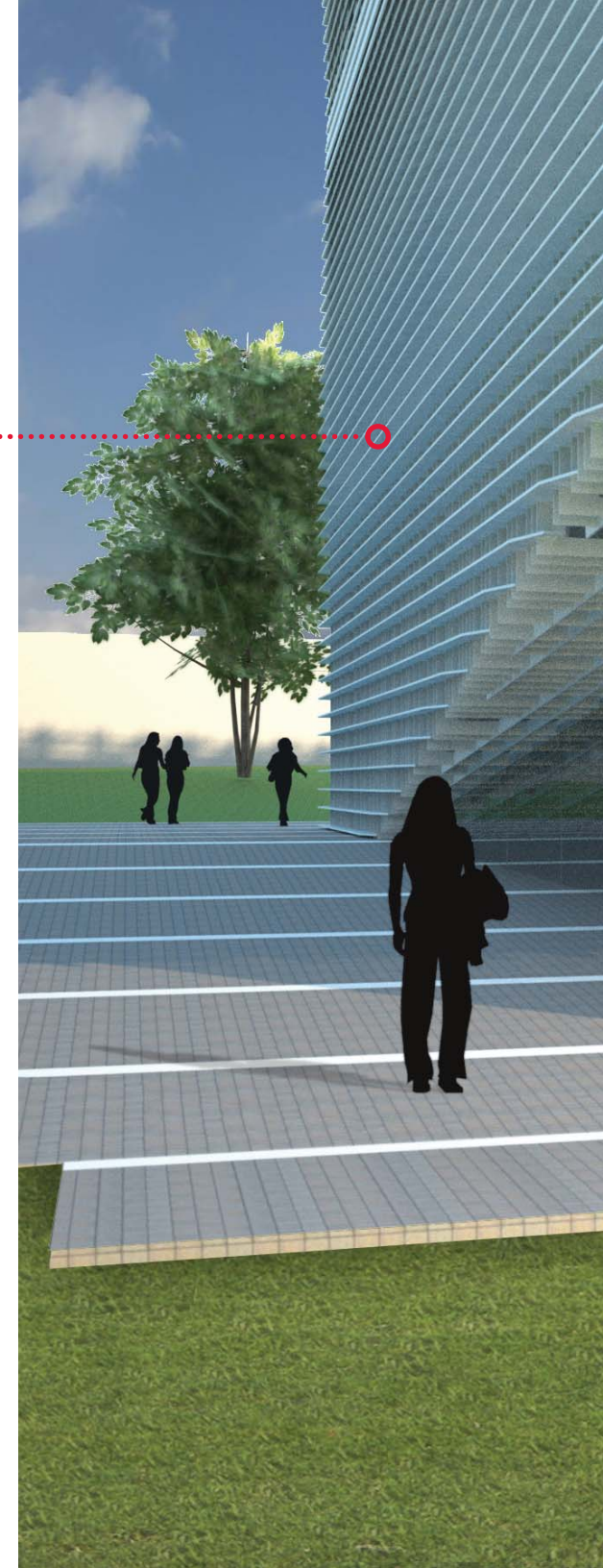

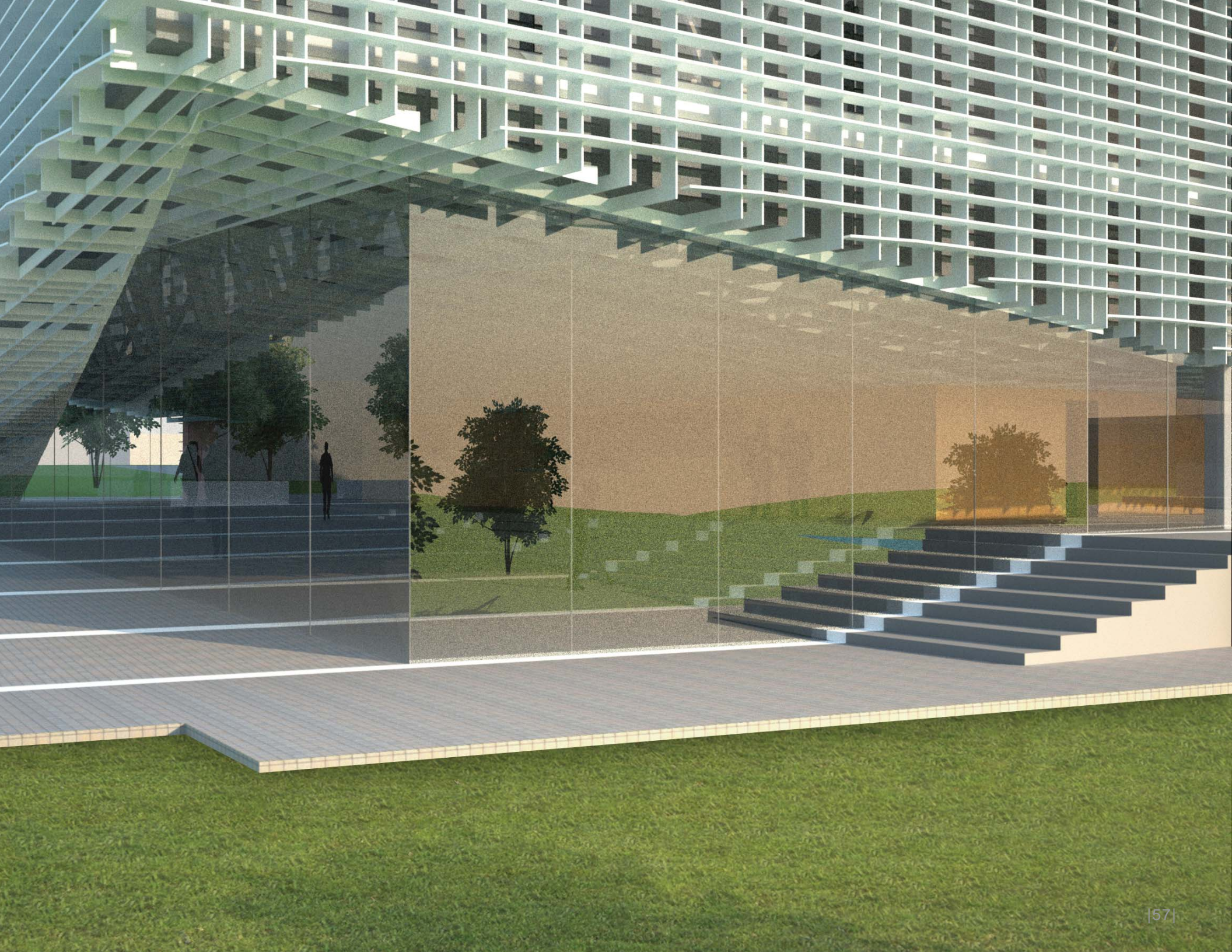

Floorplans

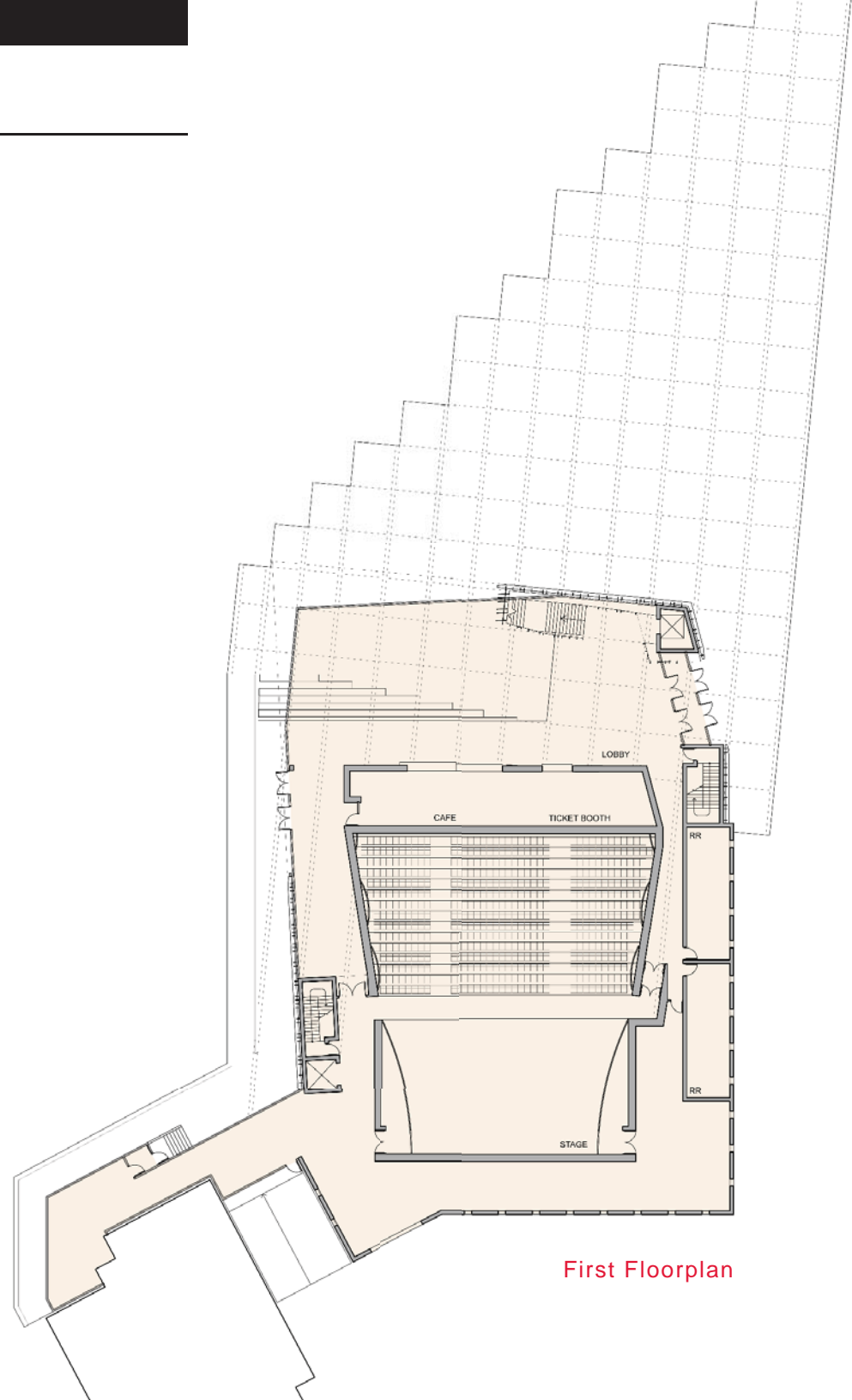

First Floorplan

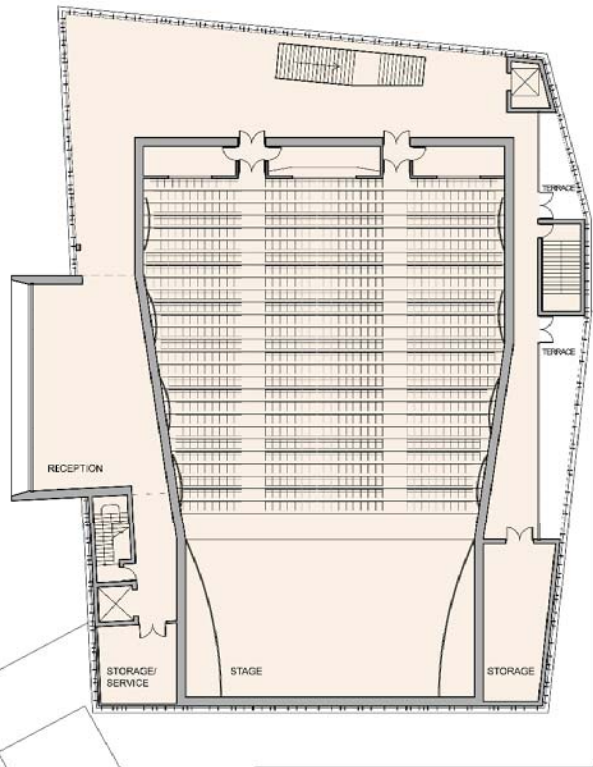

Second Floorplan

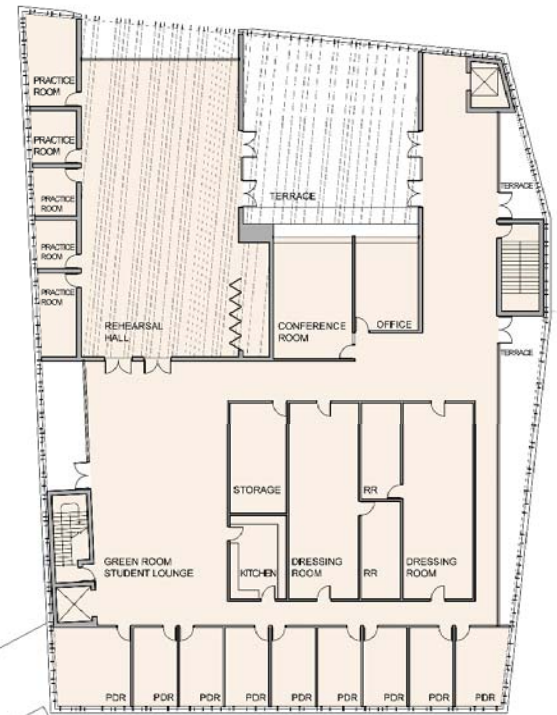

Third Floorplan

View From Across Creek

Surface

The lifting of the surface along with the sloping of the lobby allows space to flow under the building and further emphasis the inhabitant's connection to the exterior. The rotation of each horizontal louver also provided visual penetration into the building where activity takes place, but blocks the views in the intermediate zone which is not inhabited. |





Sections

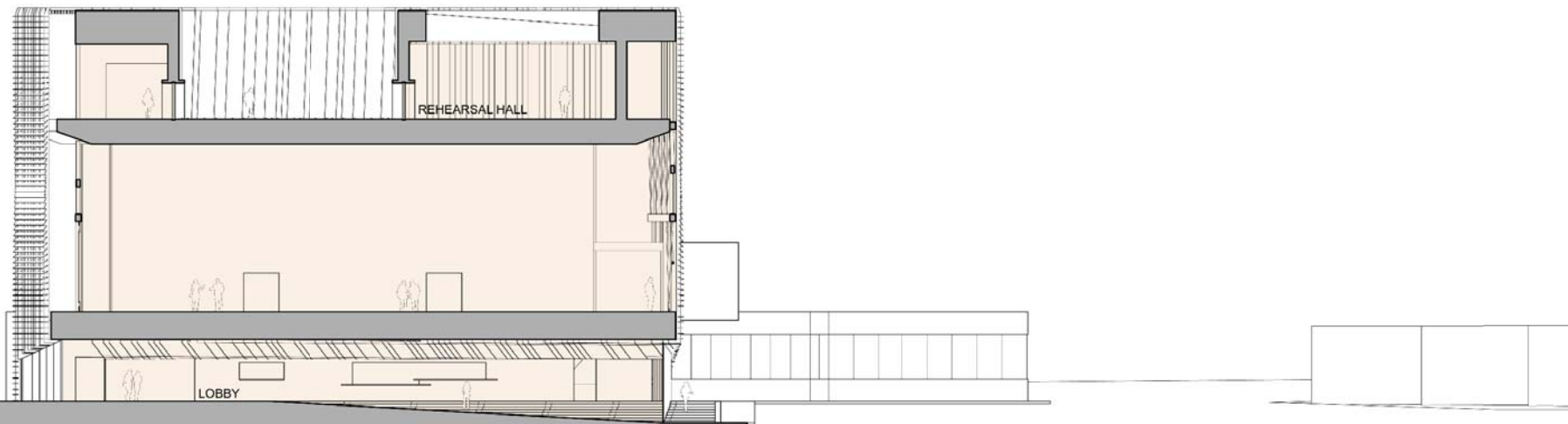

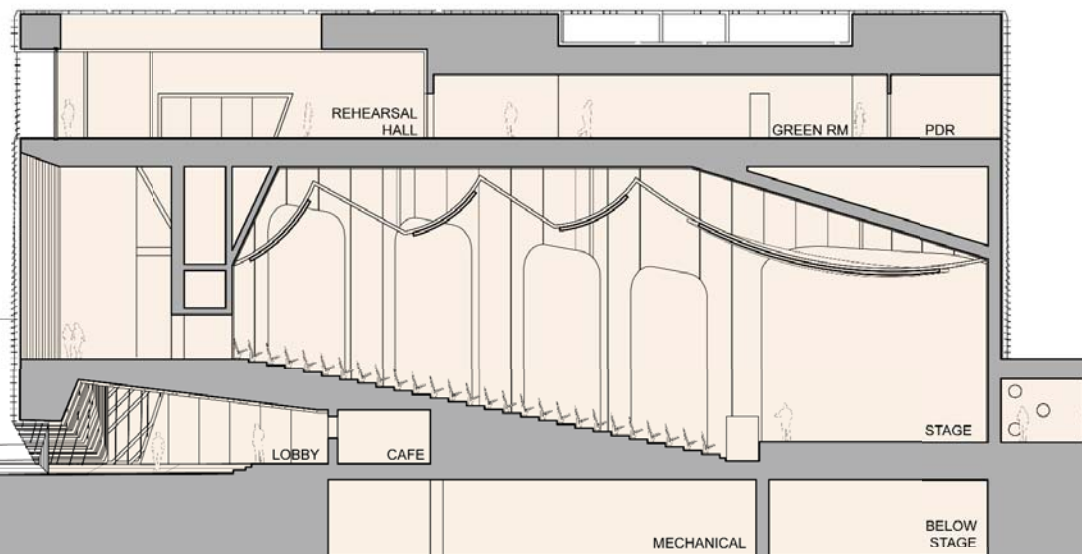

Longitudinal Section

West Elevation

Reception Area The surface is punctured to allow space for a reception area on the second level which overlooks the creek. Transparency is allowed on the third level along the rehearsal hall's private practice rooms and the exterior terrace adjacent to the green room. |



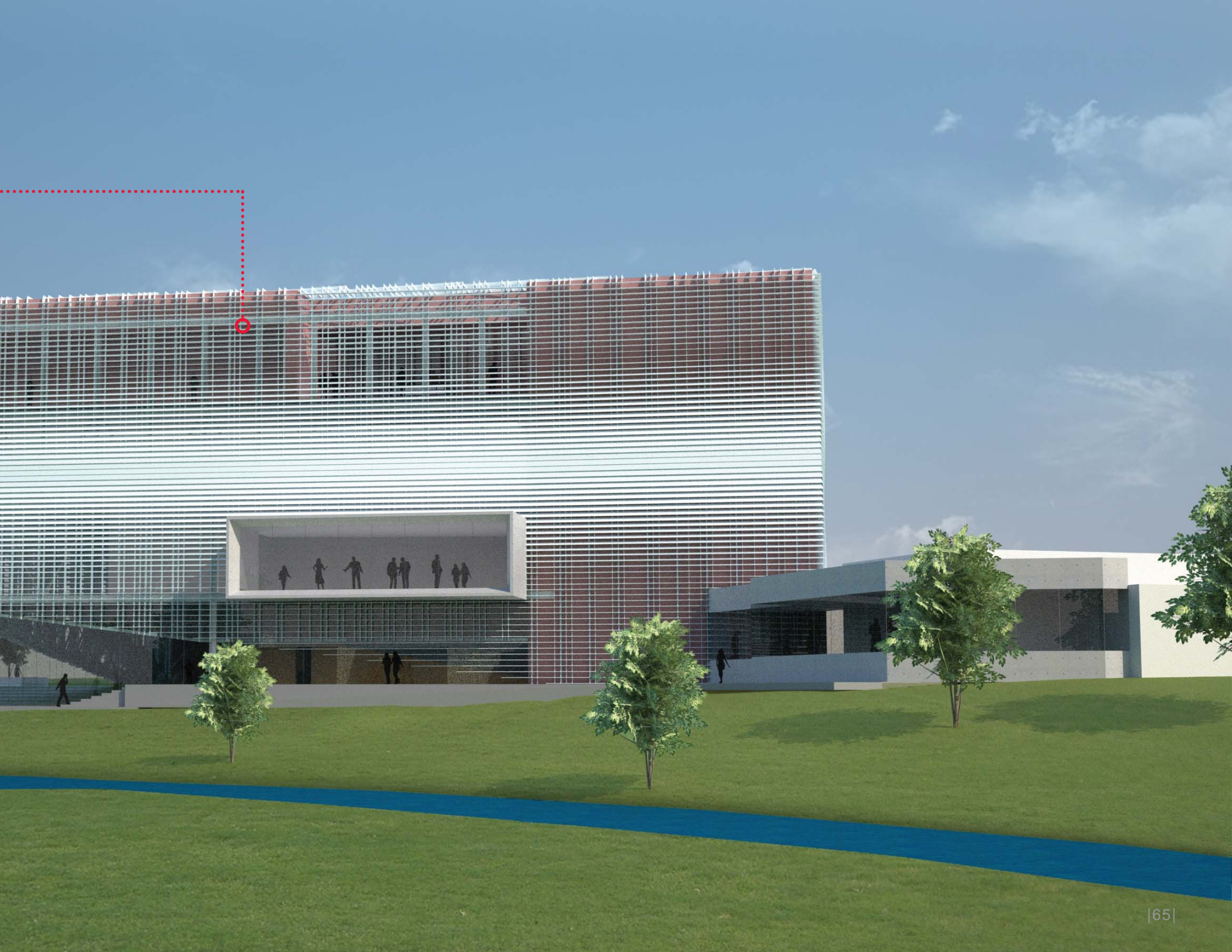

Bird's Eye Perspective

Surface

A bird's eye view of the surface shows how the horizontal louvers block solar heat gain. The vertical louvers continue to define spaces for the exterior terrace and mechanical units on the roof of the building. |.....



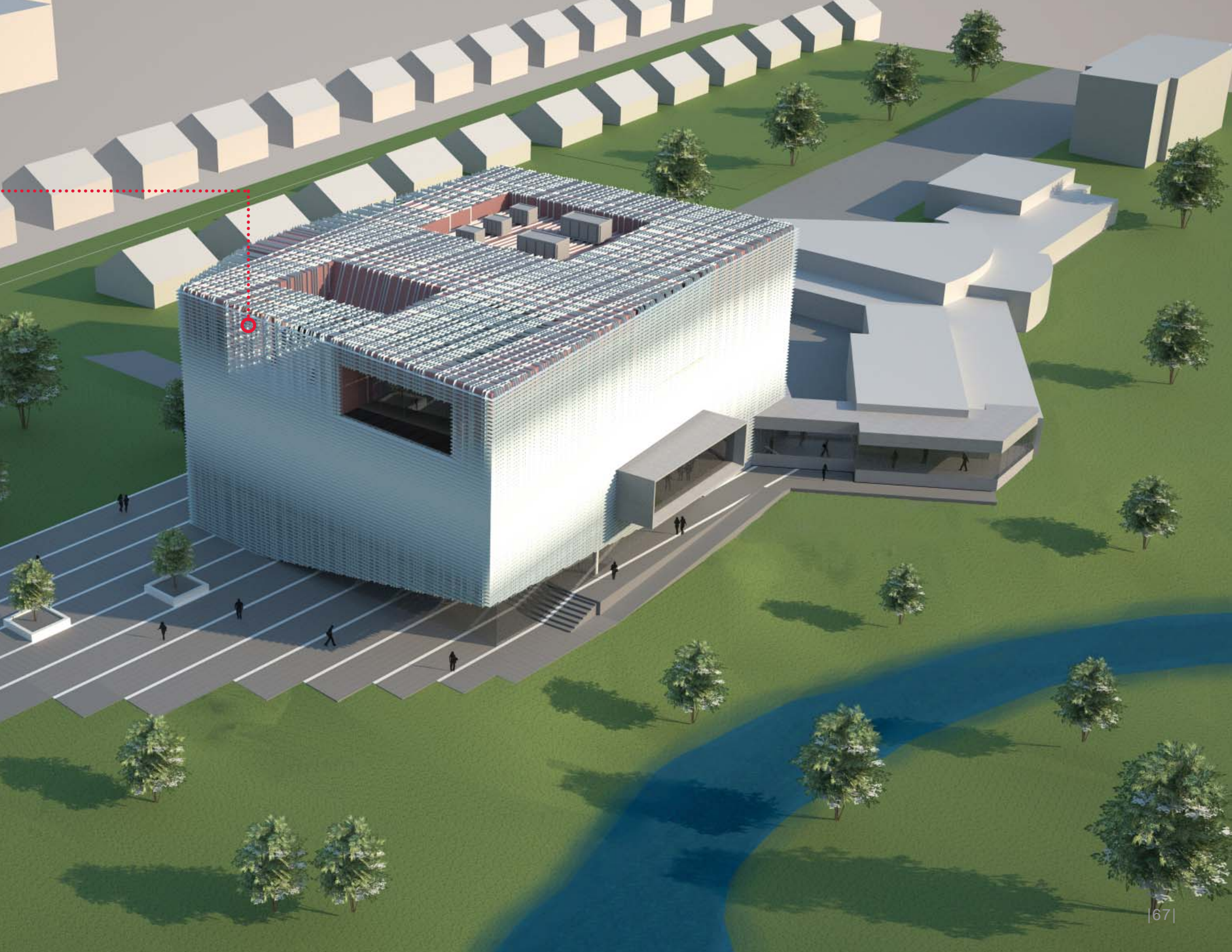

Public Access

Approach

The public's primary approach to the building occurs from the parking lot. This approach to the building provides visual penetration of the surface up through the activity zones and also provides a glimpse into the rehearsal hall and exterior terrace. The corner of the building appears to float above the plaza as the building is approached.



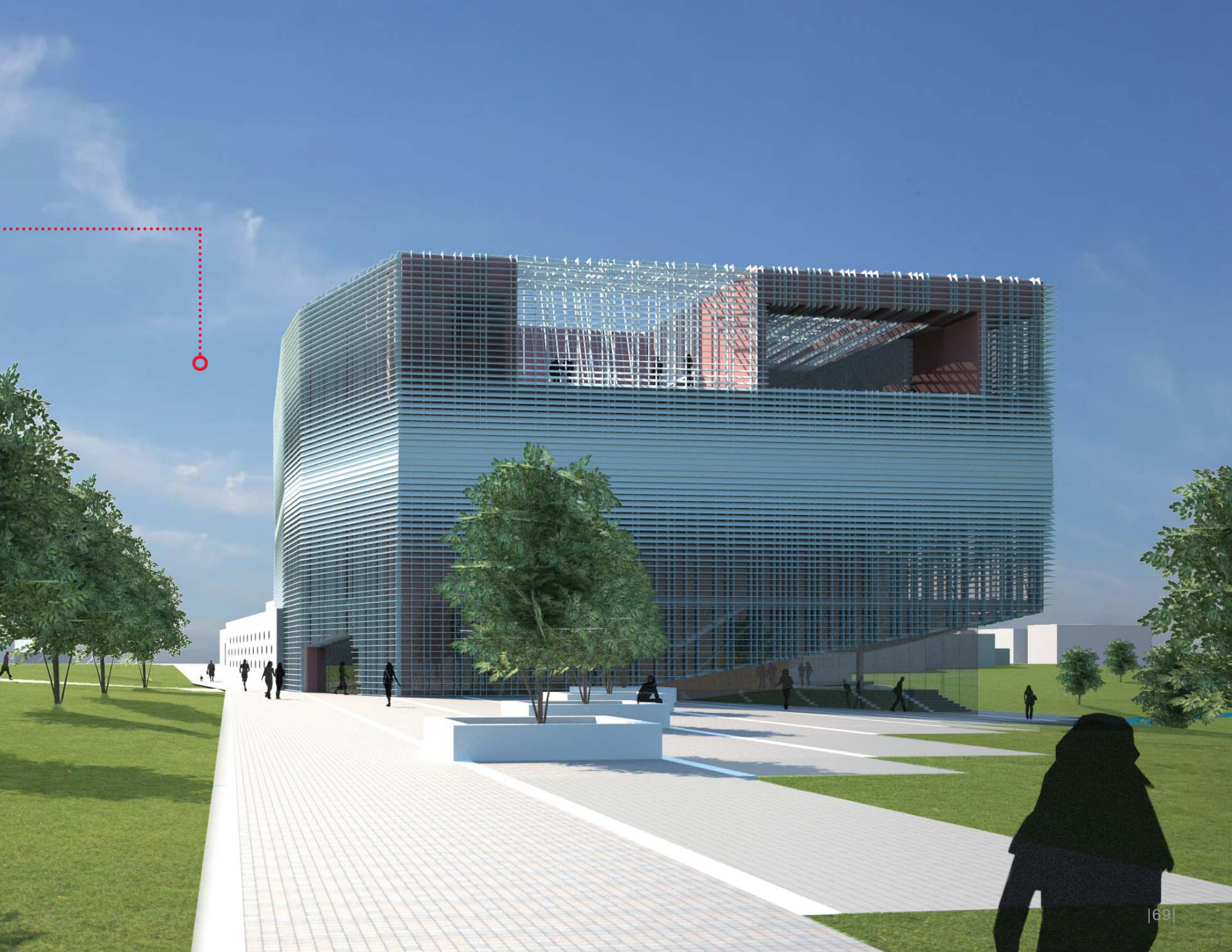

Assembly | Structure

Assembly

The composition of the surface is made up of overlapping the vertical and horizontal louvers. There are structural, vertical louvers every five feet which line up with the joints of the insulated glass which are held together by 3M structural glazing tape. These structural louvers tie into the main trusses. Between these structural louvers there are thinner, vertical louvers placed randomly to provide variation across the surface. The horizontal louvers notch into the vertical louvers and are welded into place. Both the horizontal and vertical louvers are digitally fabricated and then aligned with jigsaw connections.

Structure

In order to pull the one corner of the building up and open up the lobby without interruption from structural supports, a truss cantilevers out to pick up the weight. A similar truss is used on the opposite site of the building and trusses span the distance between to provide structural support for the floors. The third floor is built up from this truss and the second floor is hung from this truss. These two large trusses are incorporated into the vertical circulation cores for structural support.

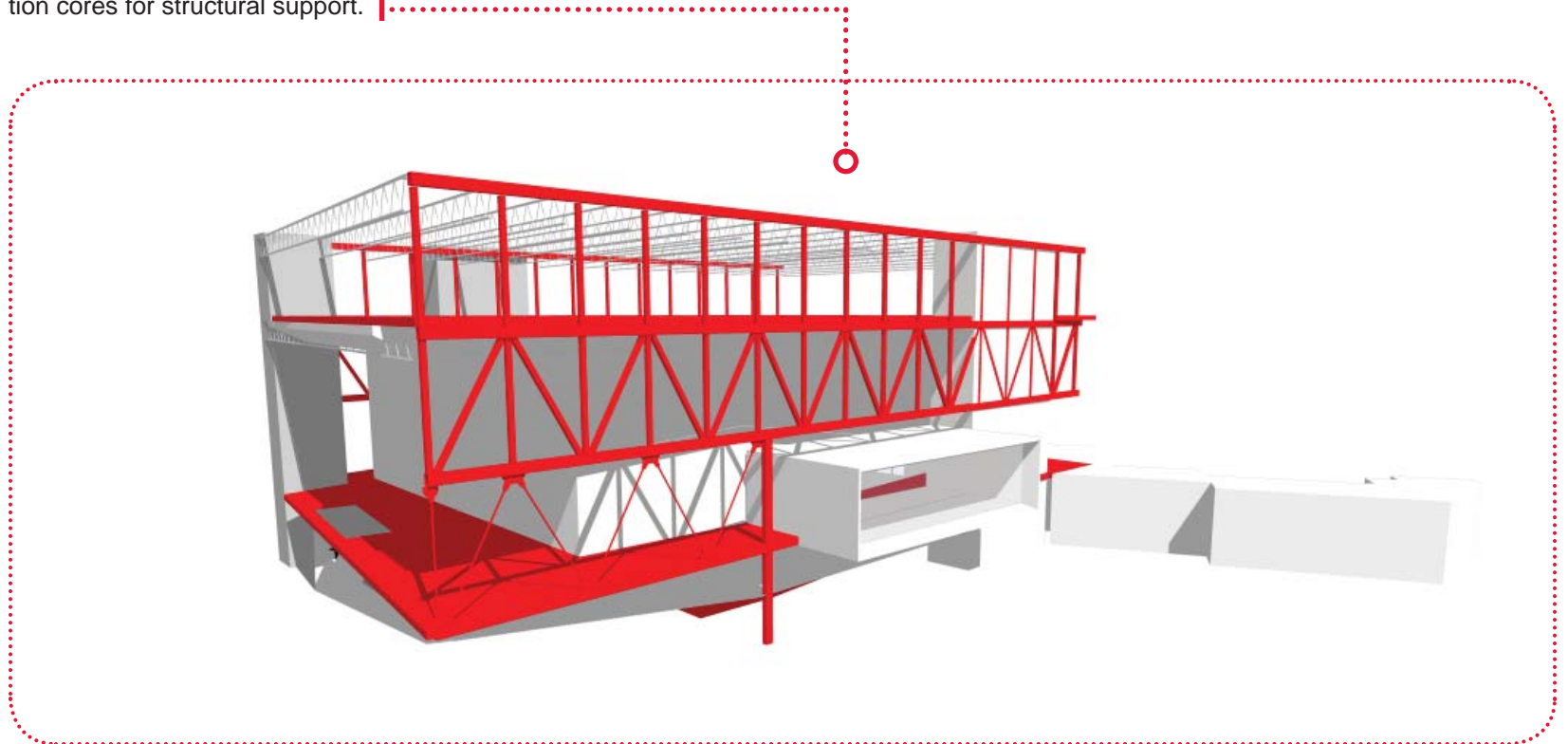

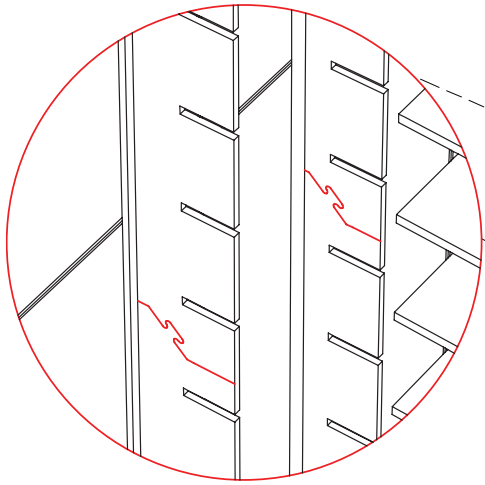

STRUCTURE

INSULATED GLASS

3M STRUCTURAL GLAZING TAPE

VERTICAL LOUVERS

HORIZONTAL LOUVERS

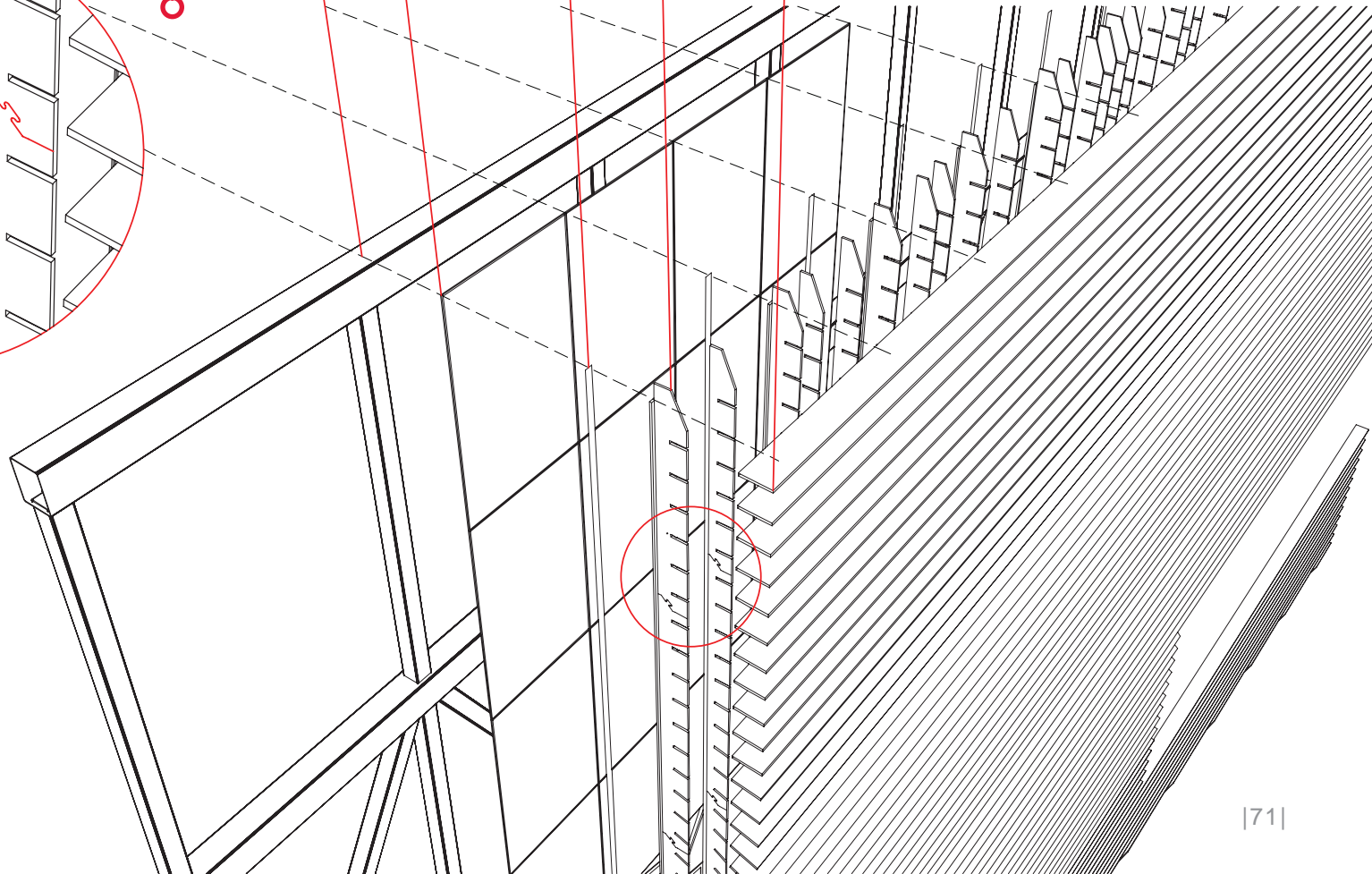

The Model

Making

The physical model is an opportunity to directly engage in the physical act of making. I chose to explore this method of working through a sectional model at half inch scale. In order to construct a scaled version (as opposed to one to one scale) the model had to be built at the precision of 1/256th of an inch. The process I used to fabricate the model is similar to that of the actual construction of the building. Similarly, I could take the same digital information and work with fabricators to construct the actual building components. The only difference would be changing the size of stock material from sheets of basswood to sheets of metal. Each piece is labeled and then matched at jigsaw shaped joints to corresponding pieces. The process of making began with assembly diagrams to organize the numbered pieces and locate them in the correct position.

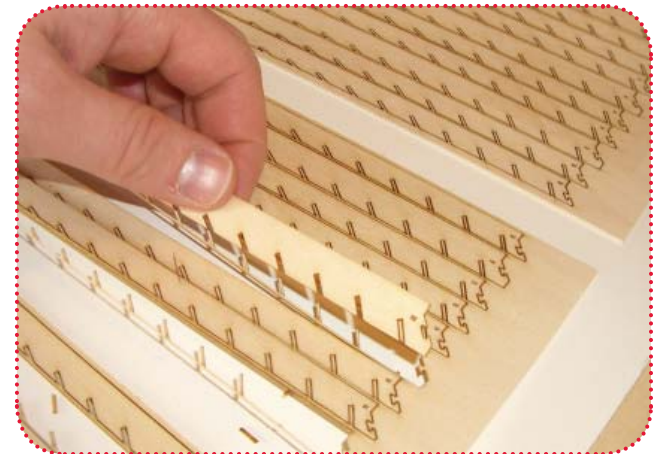
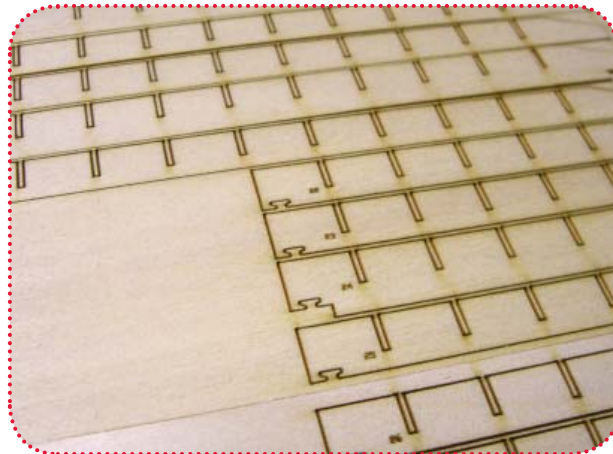



The Model

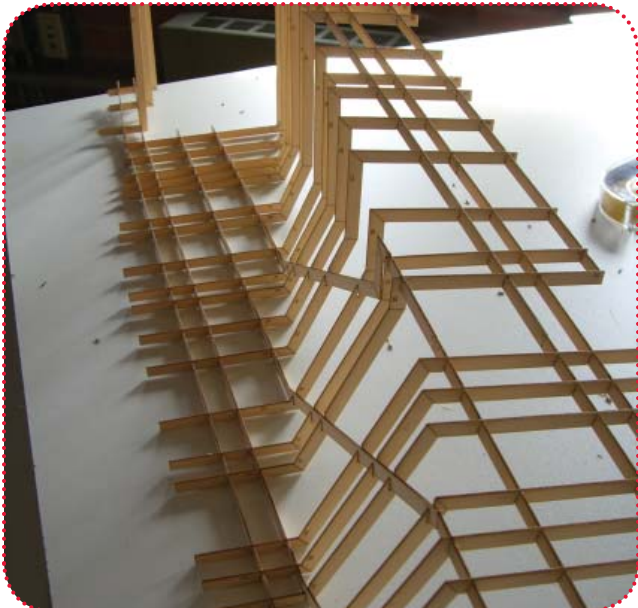
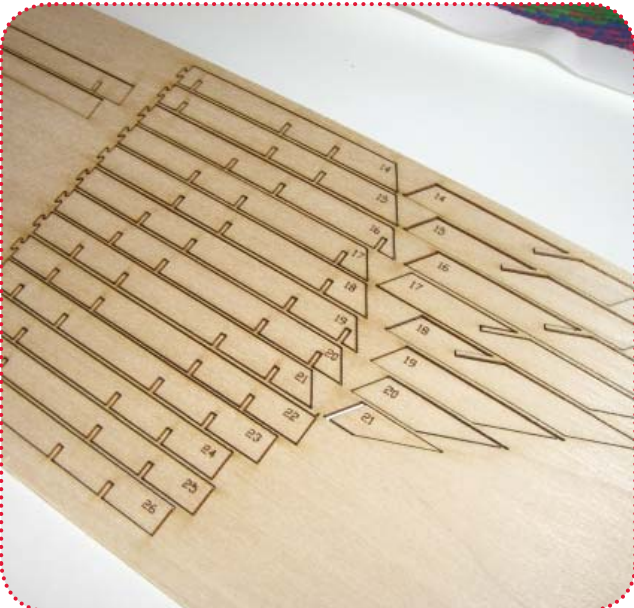
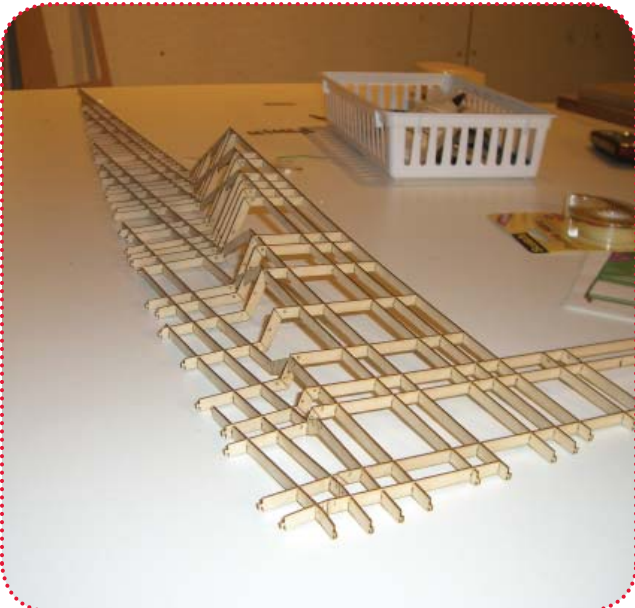



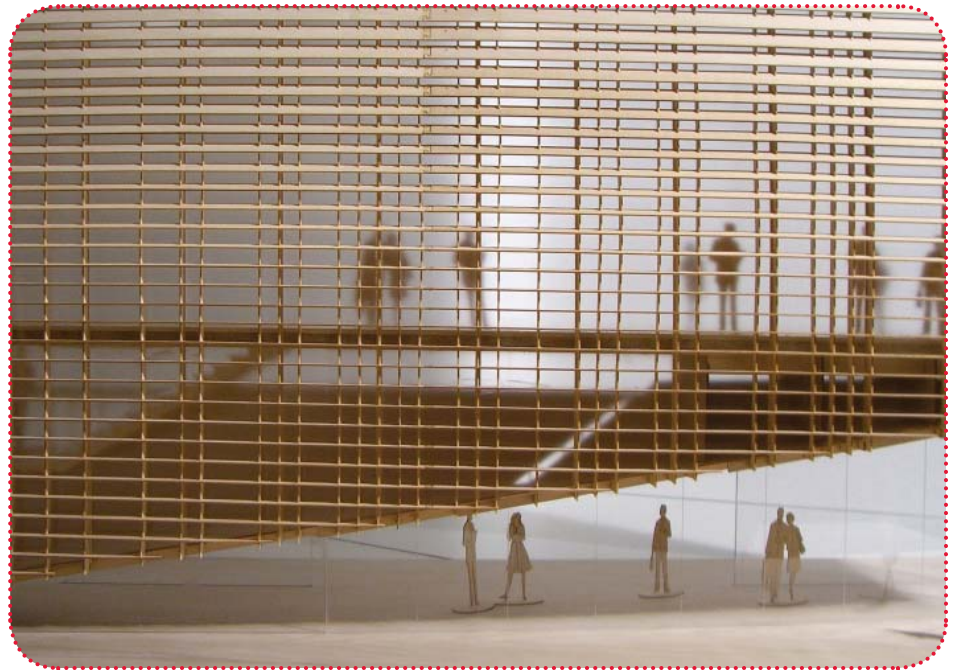
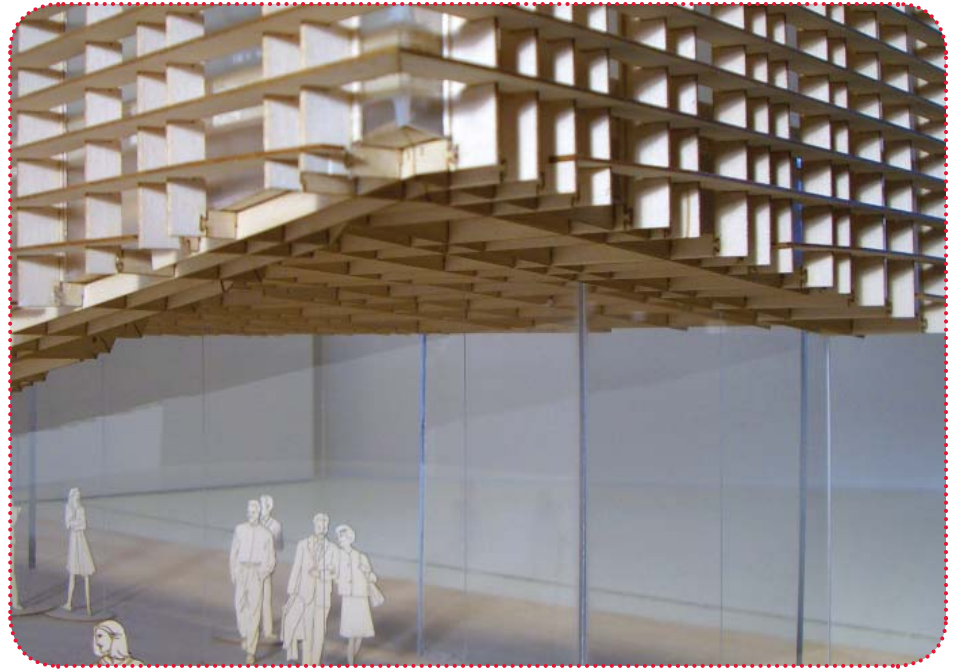

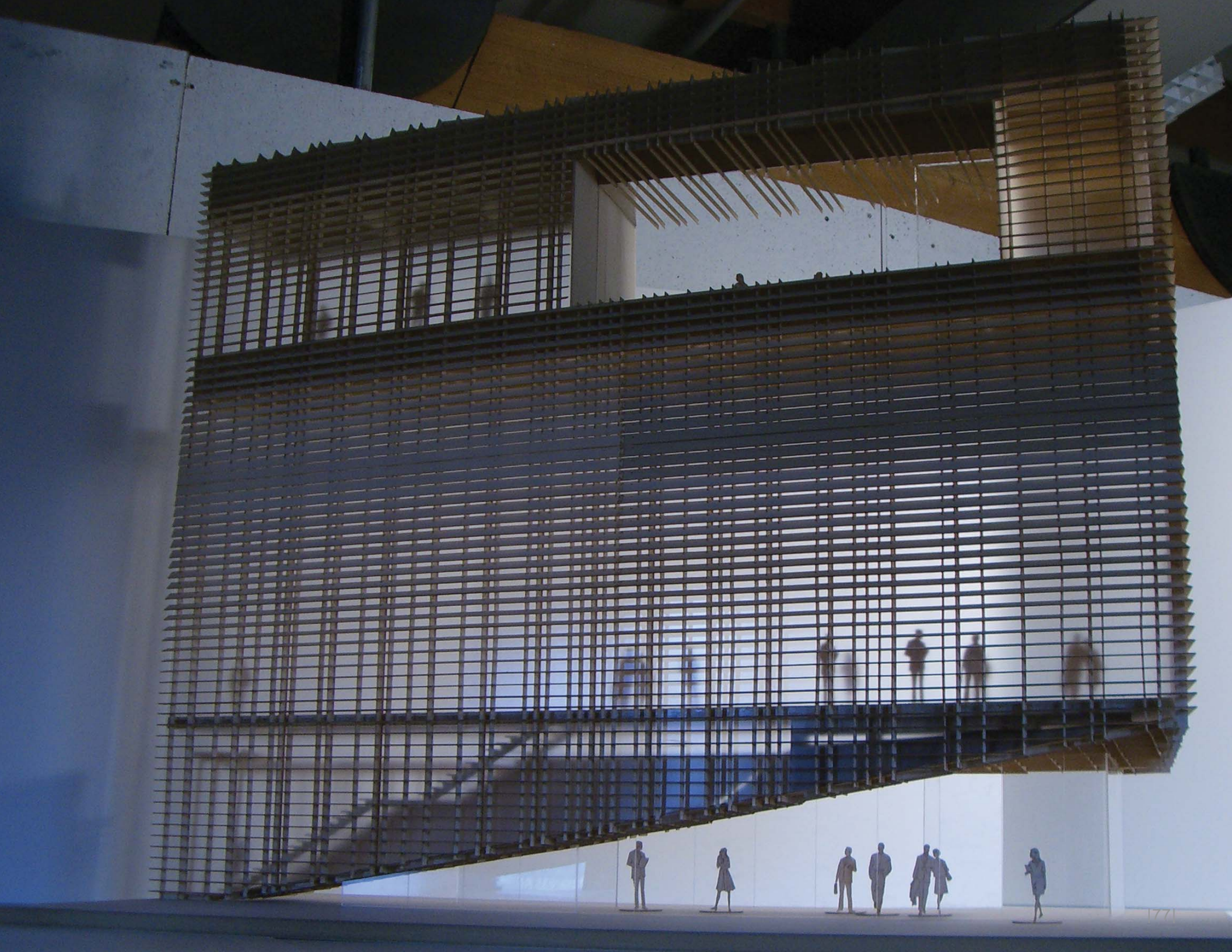

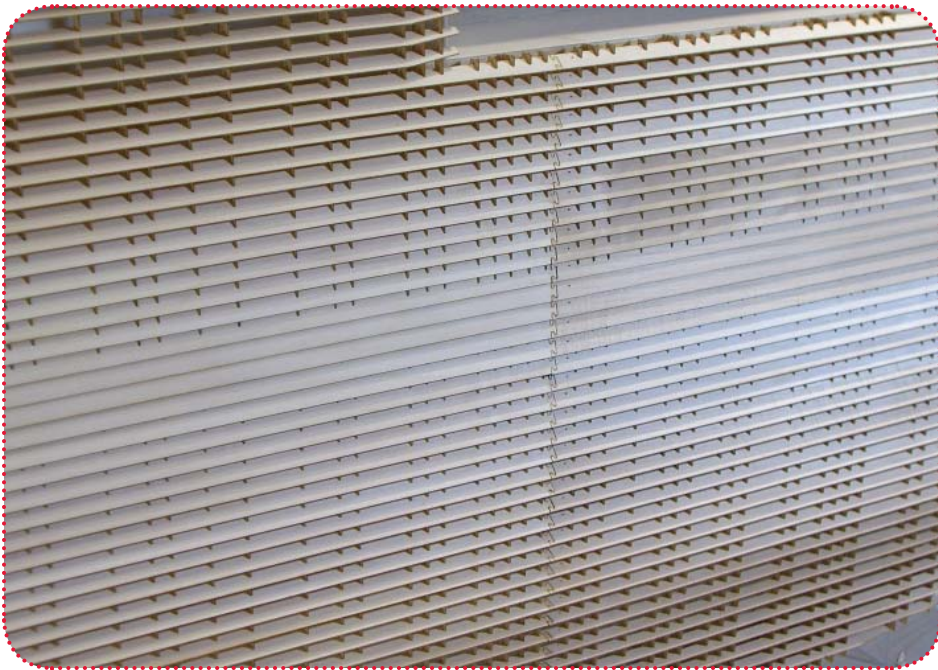
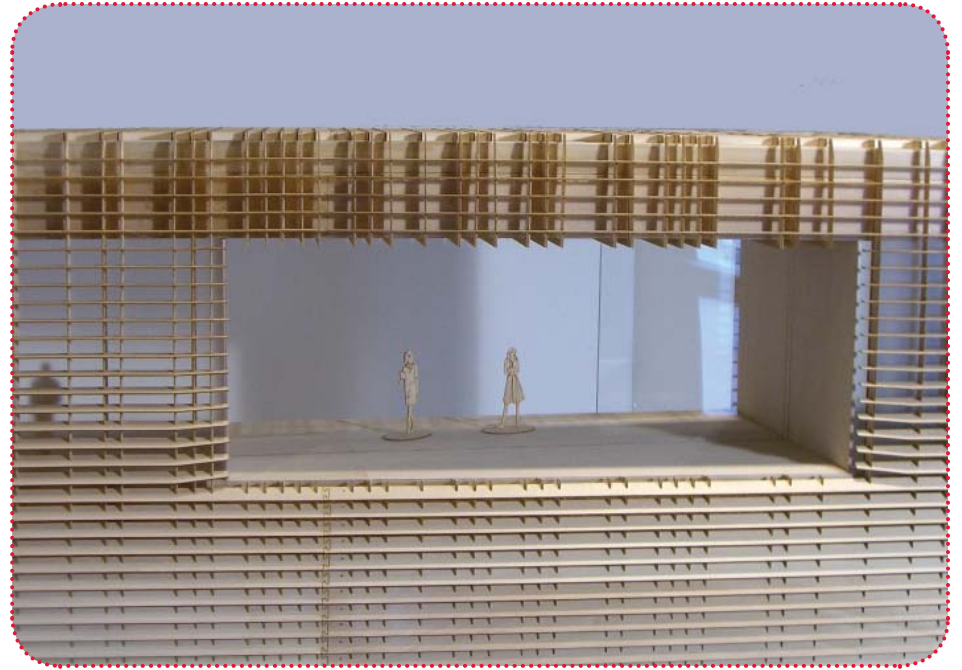
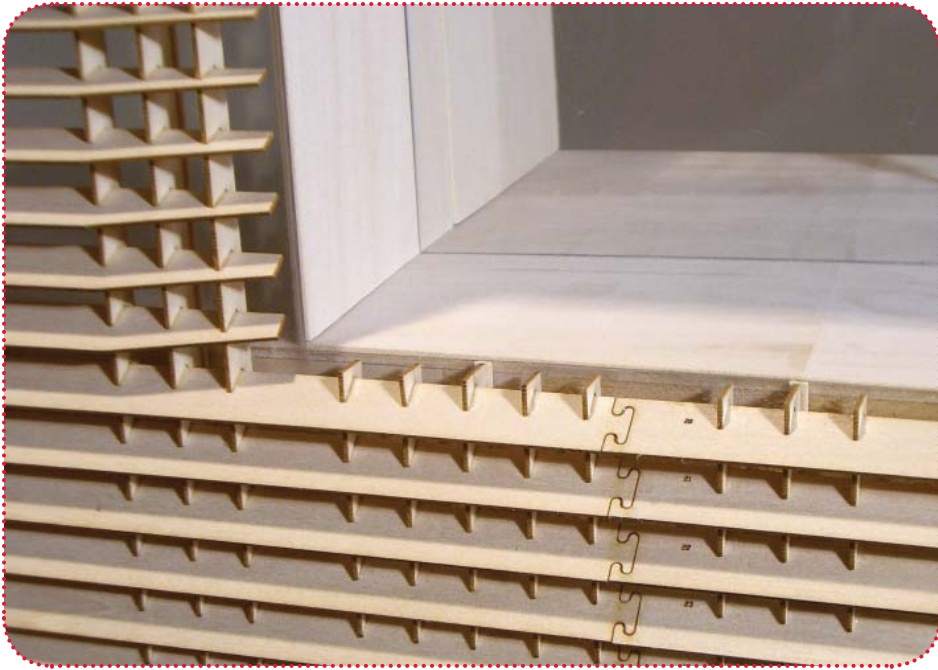

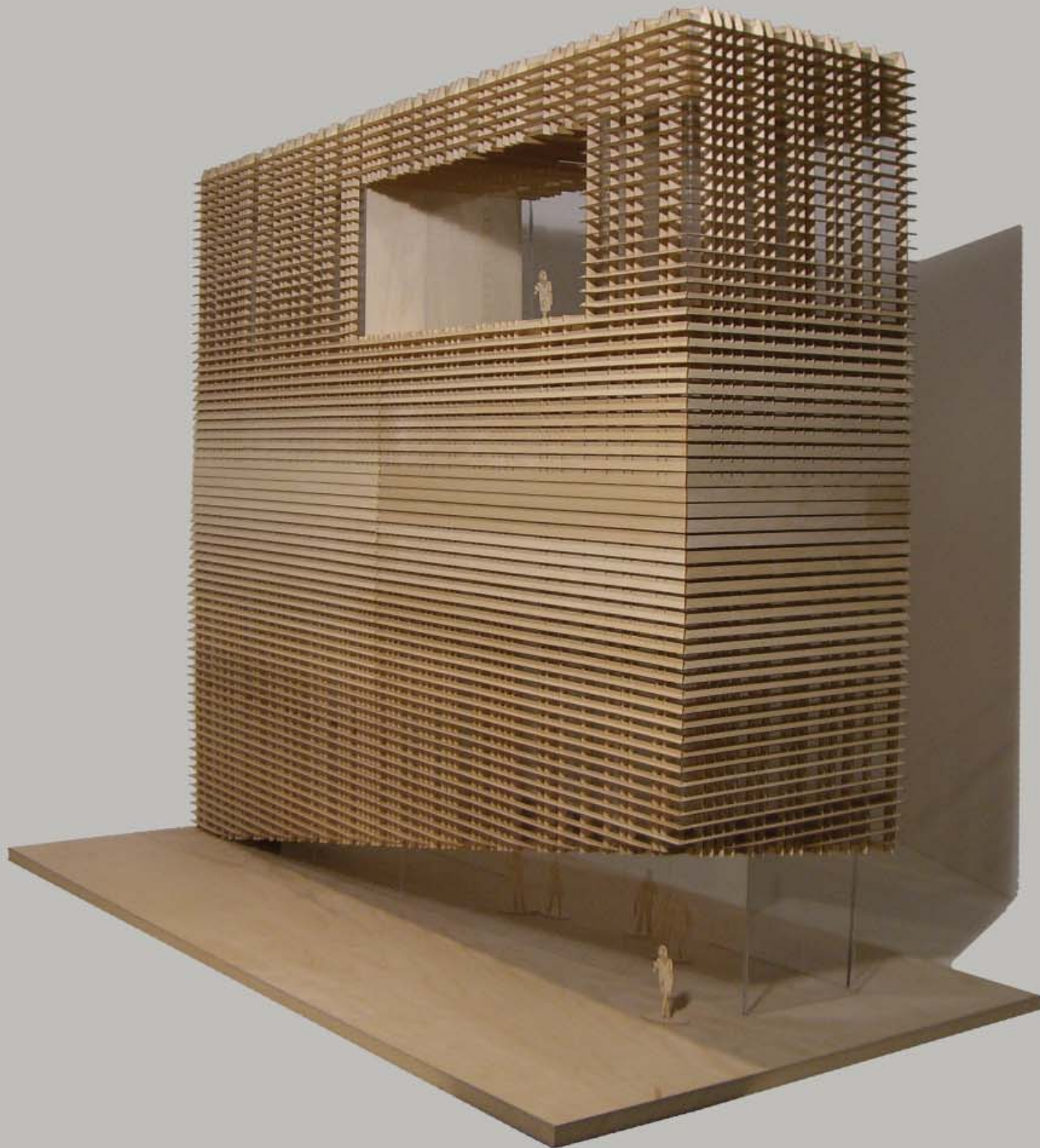

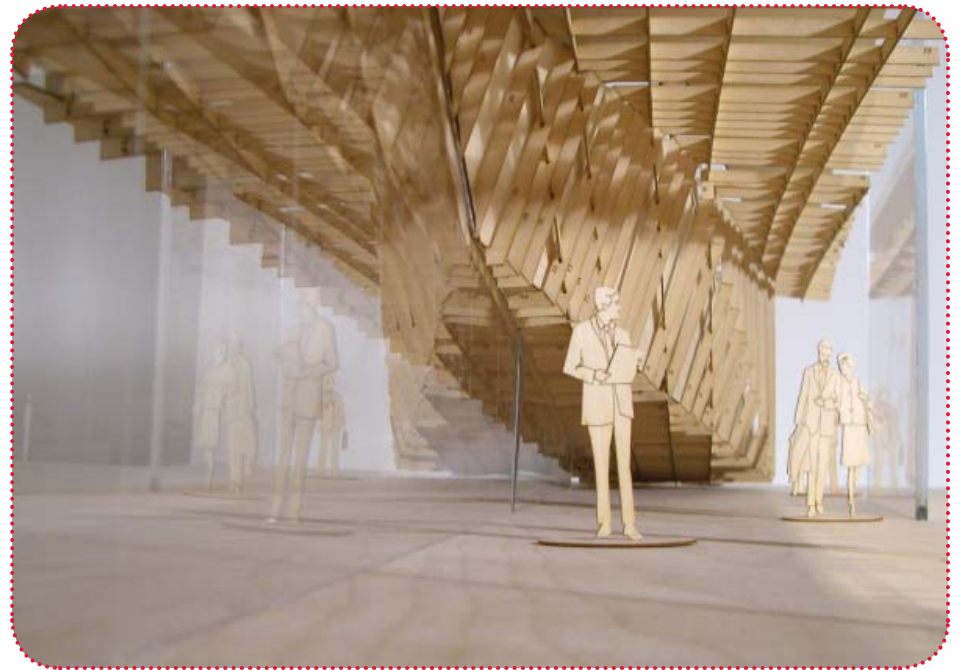
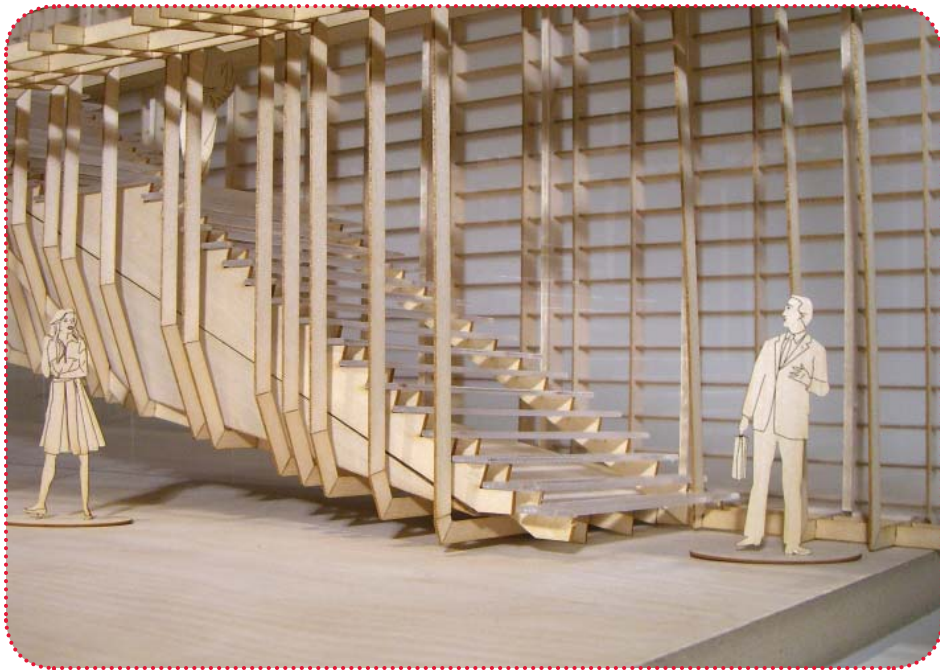
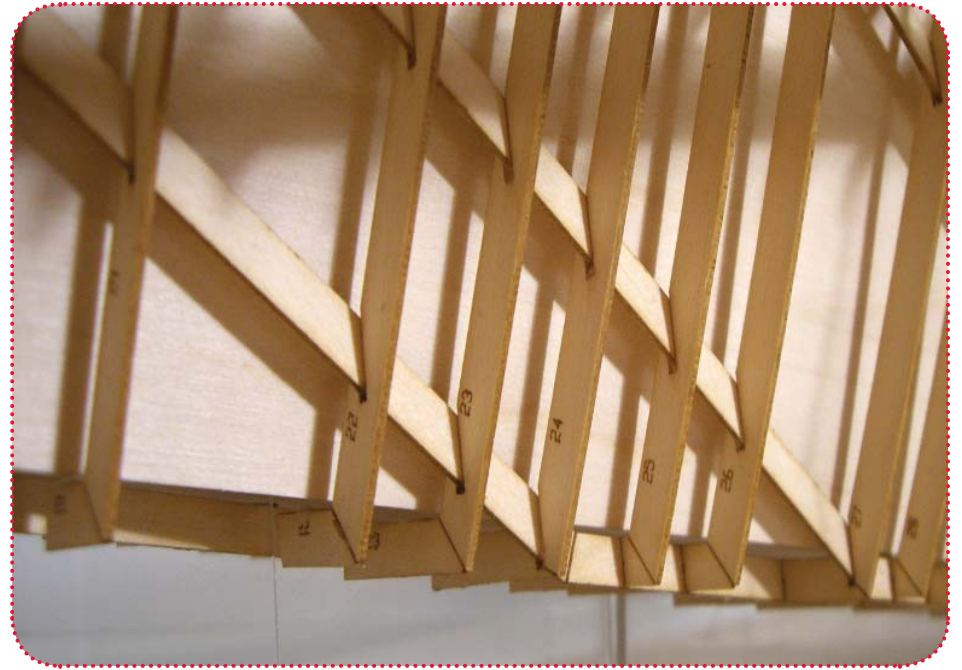
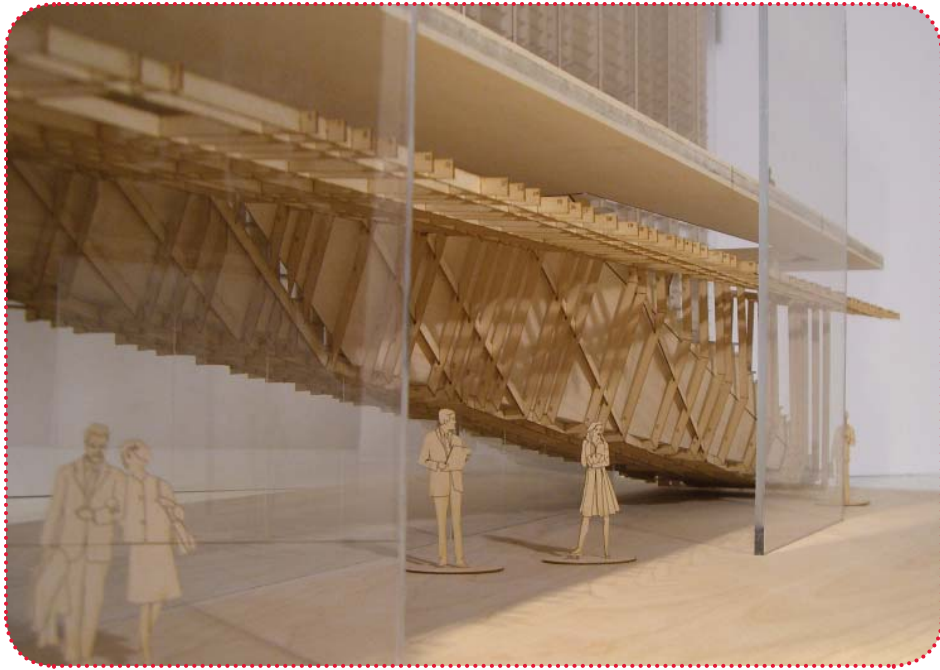





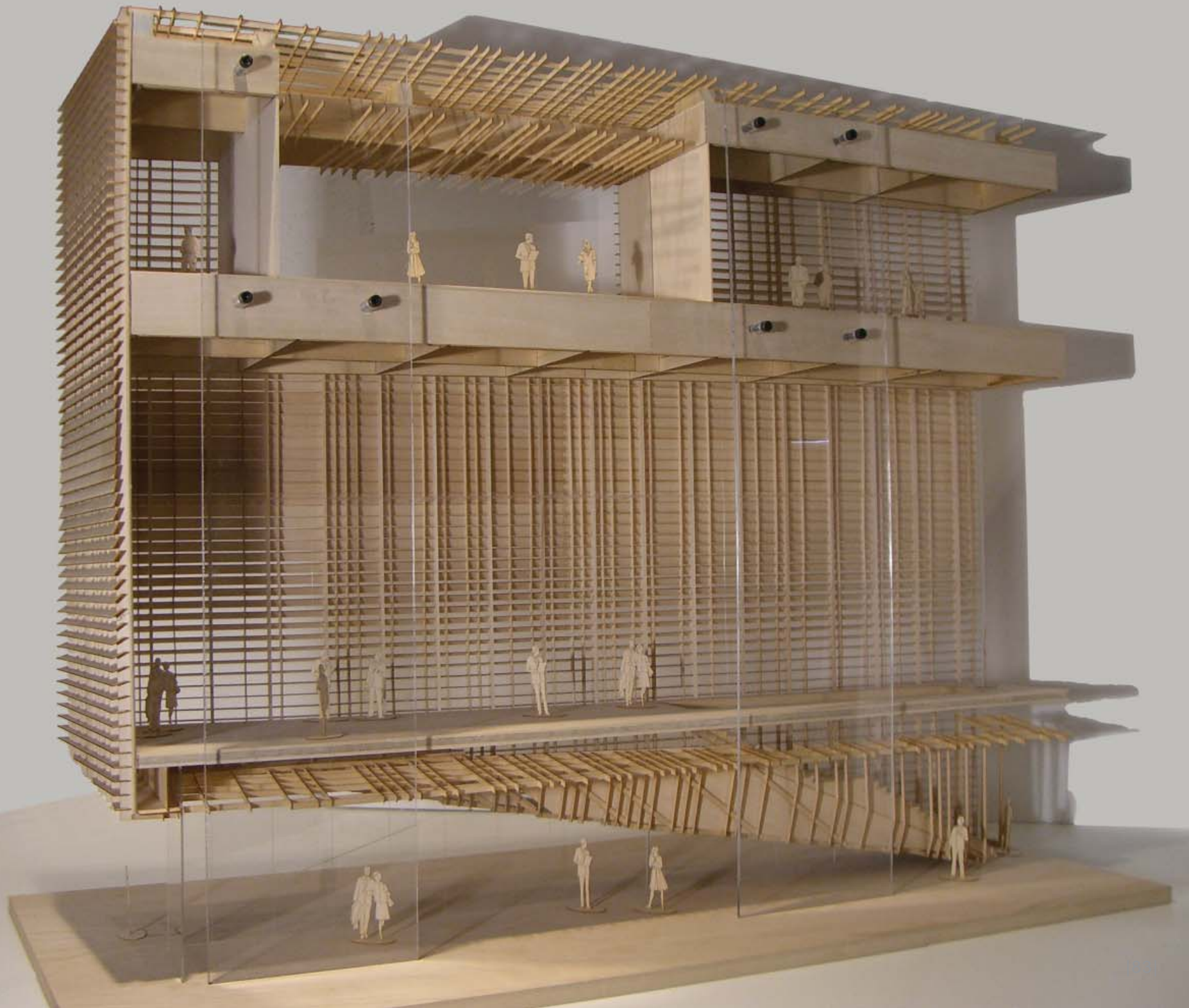

The Model | Fabrication Pieces

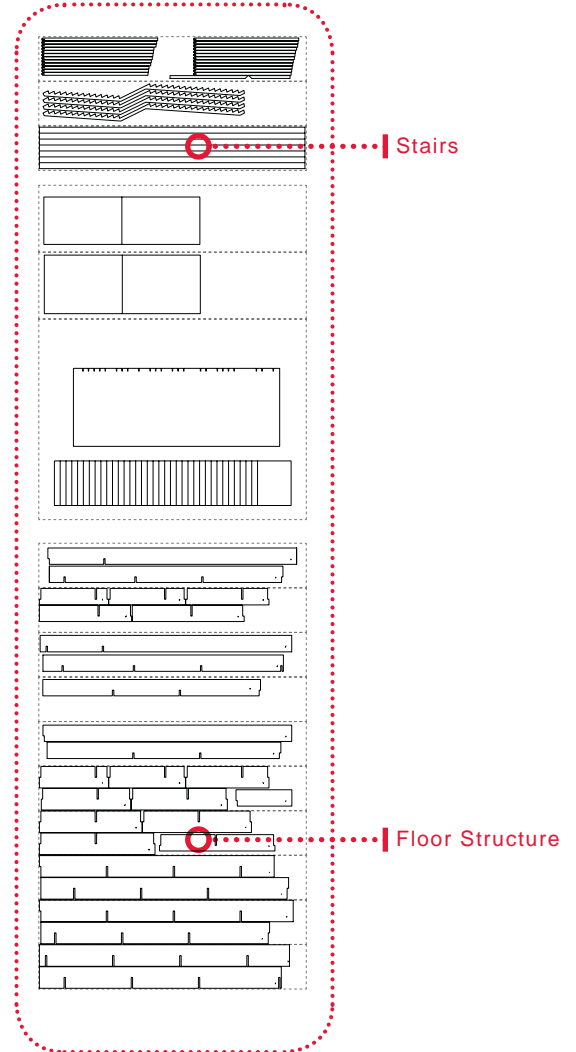
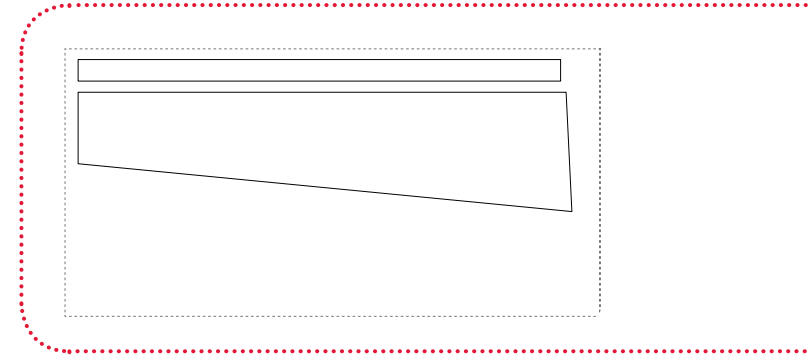
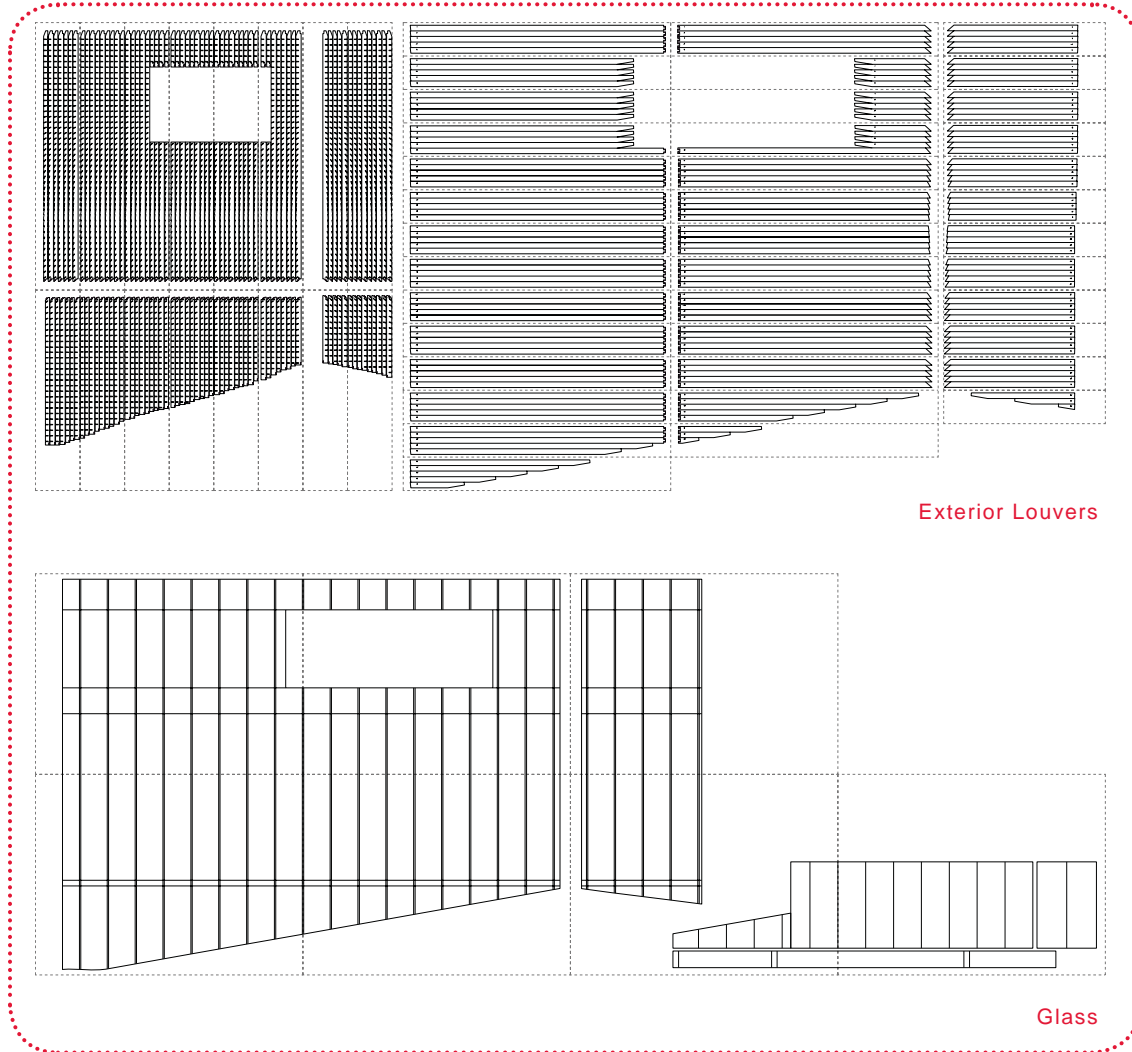

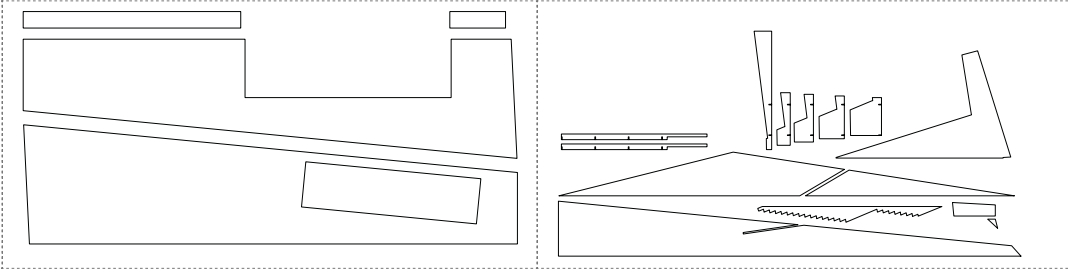

Floor Structure

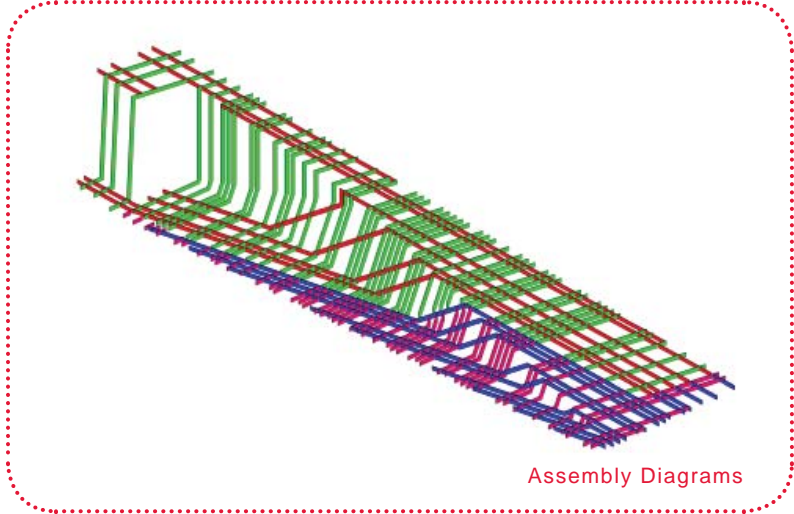
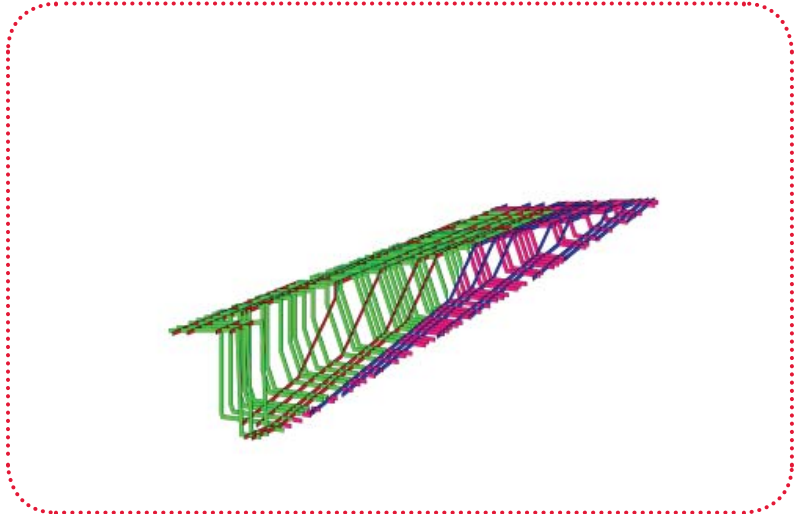

Assembly Diagrams

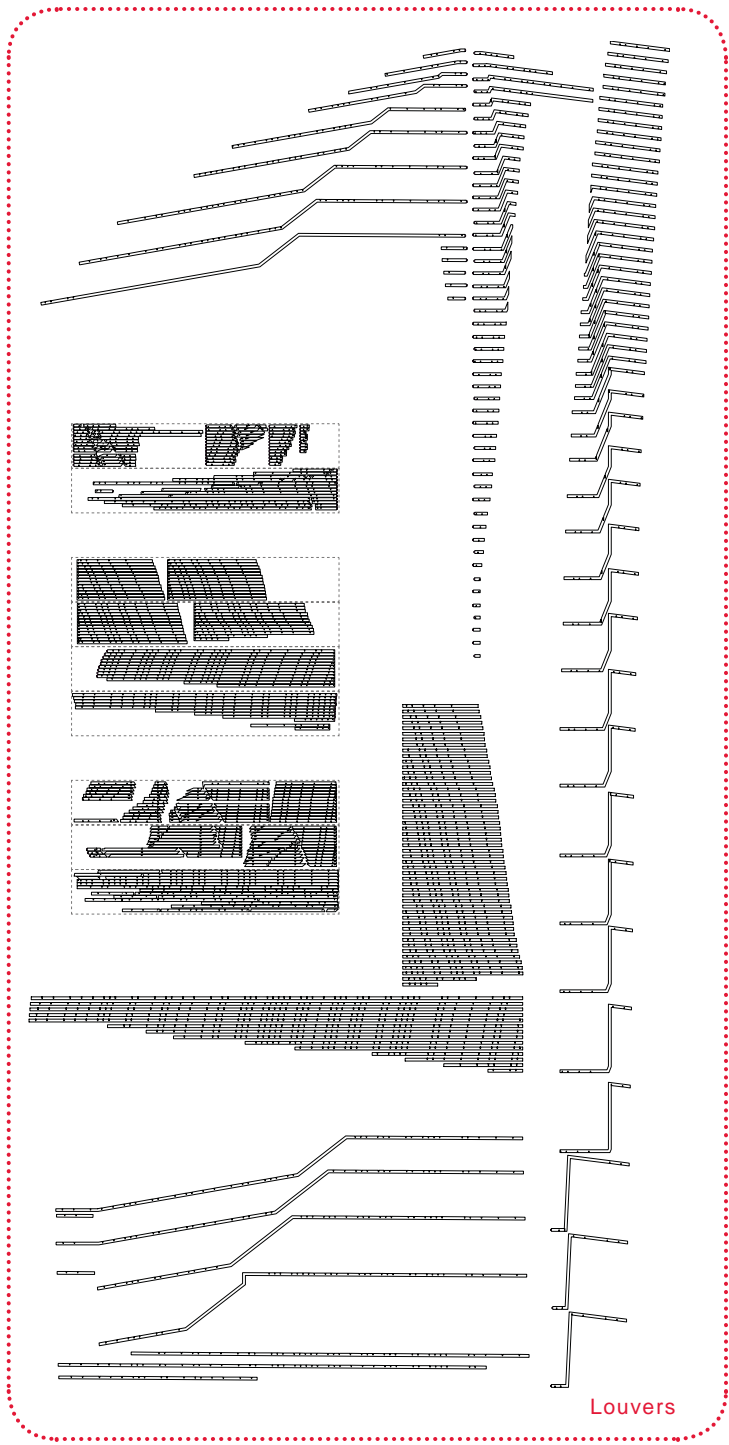

Louvers

Economy of Production | Horz. Louvers

Economy of Production

In order to create an economy of production, the vertical louvers can be broke down into segments based on material extents and connected with jigsaw shaped joints. There are two different thicknesses of louvers. The structural ones are thicker to connect back to the truss while the randomly placed ones only connect to the horizontal louvers. Each can be mass produced around the building as the intersection points with the horizontal louvers do not change. In this way, several of the pieces can be mass produced but yet become part of the surface for a unique overall expression. |.....

Horizontal Louvers

As the horizontal louvers move up the building, they rotate about their axis to provide views both into and out of the building in zones of activity but also provide protection for the building in terms of solar heat gain. This is a rather simple idea but has dramatic effect on how the building is experience. As one moves around the building, the perception of space changes in depth and visual penetration. |.....



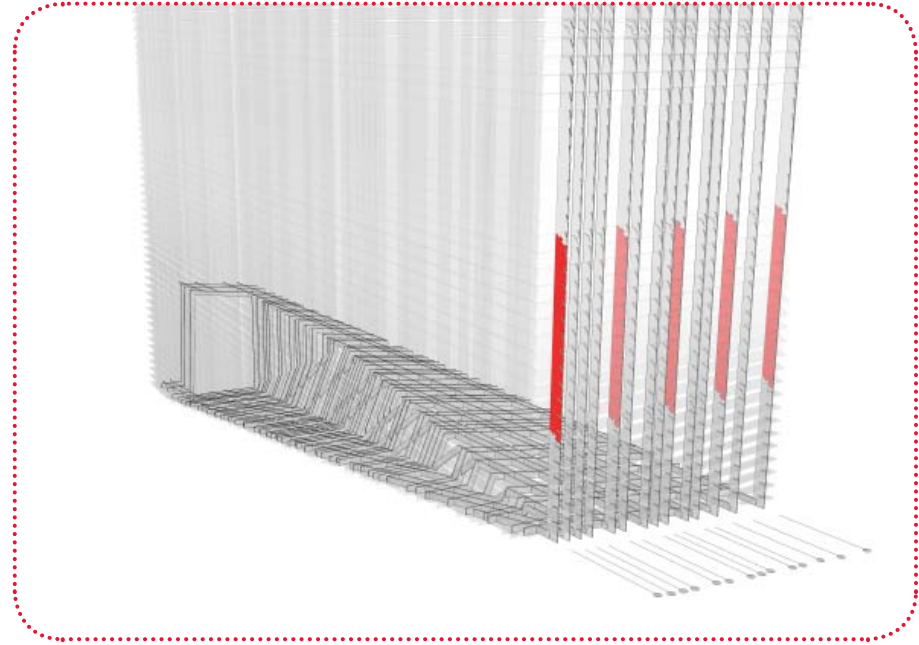
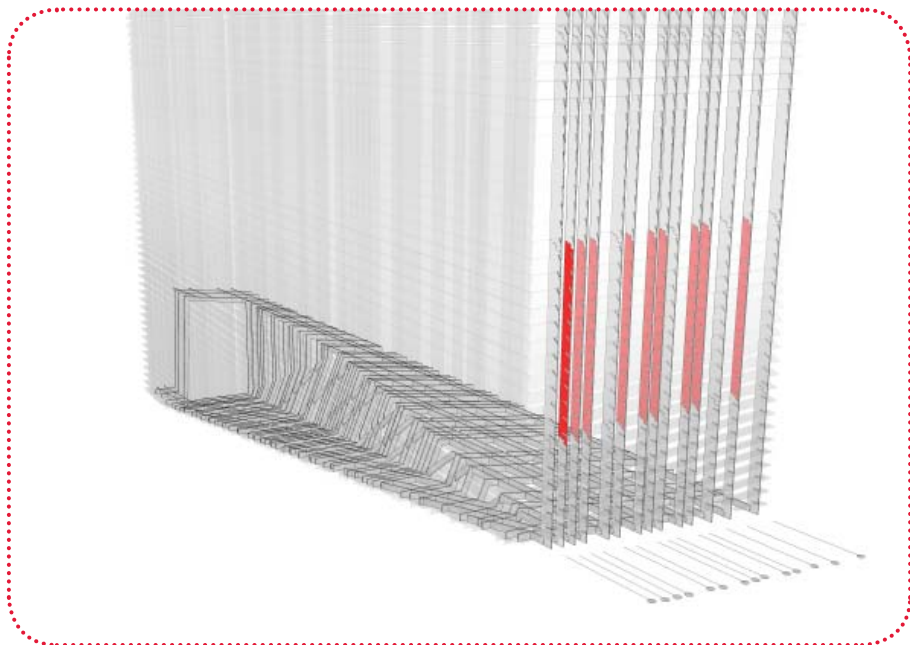
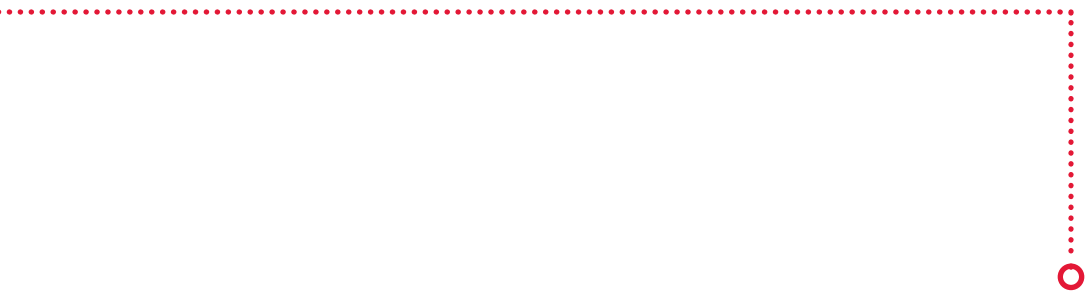

Bibliography

- Allen, Stan. *Points + Lines: Diagrams and Projects for the City*. New York: Princeton Architectural Press, 1999.
- Allen, Stan. *Pracice: Architecture, Technique and Representation*. Amsterdam: Overseas Publishing Association, 2000.
- Aranda, Benjamin and Chris Lasch. *Tooling: Pamphlet Architecture 27*. New York: Princeton Architectural Press, 2006.
- Bell, Victoria Ballard. *Materials for Design*. New York: Princeton Architectural Press, 2006.
- Brookes, Alan J. and Dominique Poole. *Innovation in Architecture*. London and New York: Spon Press, 2004.
- Castle, Helen. "Versioning: Evolutionary Techniques in Architecture." *Architectural Design* (Wiley-Academy), Sept/Oct 2002.
- Chaszar, Andre. *Blurring the Lines*. West Sussex: Wiley-Academy, 2006.
- Cirillo, Ettore and Francesco Martellotta. *Worship, Acoustics, and Architecture*. Brentwood: Multi-Science Publishing Co. Ltd., 2006.
- Grueneisen, Peter. *SoundSpace: Architecture for Sound and Vision*. Boston: Birkhauser, 2003.
- Kolarevic, Branko. *Architecture in the Digital Age: Design and Manufacturing*. New York: Taylor & Francis, 2003.
- Leach, Neil. *Designing for a Digital World*. West Sussex: Wiley-Academy, 2002.
- Libeskind, Daniel. *The Space of Encounter*. New York: Universe Publishing, 2000.
- Martin, Elizabeth. *Architecture as a Translation of Music: Pamphlet Architecture 16*. New York: Princeton Architectural Press, 1994.
- Mayne, Thom and Val Warke. *Morphosis*. Phaidon, 2003.
- McCue, Edward and Richard H. Talaske. *Acoustical Design of Music Educational Facilities*. Syracuse: The Acoustical Society of America, 1990.

Bibliography (continued)

Mehta, Madan, Jim Johnson, and Jorge Rocafort. *Architectural Acoustics: Principles and Design*. Columbus: Prentice Hall, 1999.

Ojeda, Oscar Riera. *Materials: Architecture in Detail*. Gloucester: Rockport Publishers, Inc., 2003.

Rahim, Ali. *Catalytic Formations: Architecture and Digital Design*. New York: Taylor & Francis, 2006.

Reeser, Amanda and Ashley Schafer. "Praxis: Expanding Surface." *Praxis Inc.*, 2007: Issue 9.

Reeser, Amanda and Ashley Schater. "Praxis: New Technologies://New Architectures." *Praxis Inc.*, 2004: Issue 9.

Zaera-Polo, Alejandro, and Farshid Moussavi. *Phylogenesis: FOA's Ark*. London: Actar, 2004.

Zahner, L. William. *Architectural Metal Surfaces*. Hoboken: John Wiley & Sons, Inc., 2005.

Acknowledgements

Mentor Jeffrey L. Day

Critics Martin Despang
Chris Ford
Tim Hemsath
Doug Jackson
Hyun Tae Jung

Guest Critics Keith Mitnick _ University of Michigan
E.B. Min _ Min | Day

Consultants Robin R. Koozer _ Hastings College Chair of Music Department
Lily Wang, Ph.D., P.E. _ Acoustical Engineer
Edward B. Hurd _ Omaha Performing Arts, Director of Operations

Nicole Thank you for putting up with the late nights away from home. Your love and support over that last six years continues to inspire me.

Family I would also like to thank my family for the strong foundation set to propel my career as an architect. Thank you Mom for the creative thinking and artistic talent and Thank you Dad for teaching me the crafts of building.

Professional Thank you to my colleagues and professors who have each added to my experience over the past six years. Thank you, Mr McCarthy, for teaching me the fundamentals of drawing long before I entered college.

Reflections

Explorations

The design thesis, similar to the design process, benefits from exploration. The architect is not expected to brilliantly spout ideas in perfect order or relevance to any given project but instead expected to explore several ideas. Successful design comes from an iterative process encompassing several ideas and then working each through to discover new possibilities. This process can be a time intensive and stressful experience but through these explorations new relationships and opportunities present themselves.

Competing Ideas

My intentions were to explore surface through digitally fabricated constructs. Several forces were acting on my project simultaneously: surface, digital fabrication, the physical act of making, and concert hall design. At times, these areas of exploration were at odds with one another, but it was through the overlap of competing ideas that relationships began to develop. This project was certainly not about acting on one single idea but the interrelation and overlap of several related ideas. Throughout the project, consideration was given to eliminating some of these ideas and more fully explore one singular idea, but this would have been a horrible mistake. Even the elimination of one would have drastically changed the trajectory and richness of the project. Though the exploration of several ideas can be daunting, the relationships that develop are invaluable in the educational process as well as contemporary architectural practice.

Making

My aspirations to ultimately construct a physical manifestation of my explorations presented several challenges in the format of the design thesis. The time constraints of one year hardly leave room for a methodology that includes building ones design. Often this results in poorly developed design to provide adequate building time. I chose to digitally fabricate scaled versions in similar means and methods that would be used to construct the one to one version. This led to a way of working with digital fabrication machines that ultimately created a dependence on their operability and working order. As with all new technologies, there will be challenges and setbacks, but the reward of persevering through these challenges has enriched my design process with a methodology that allows fabrication methods to influence my design.